

2.4-GHz RF Front End, 14-dBm output power

FEATURES

- Seamless Interface to 2.4-GHz Low Power RF Devices from Texas Instruments
- Up to +14-dBm (25mW) Output Power
- 6-dB Typical Improved Sensitivity on CC24xx and CC2500, CC2510, and CC2511
- Few External Components
 - Integrated Switches
 - Integrated Matching Network
 - Integrated Balun
 - Integrated Inductors
 - Integrated PA
 - Integrated LNA
- Digital Control of LNA Gain by HGM Pin
- 100-nA in Power Down (EN = PAEN = 0)
- Low Transmit Current Consumption
 - 22-mA at 3-V for +12-dBm, PAE = 23%
- Low Receive Current Consumption
 - 3.4-mA for High Gain Mode
 - 1.8-mA for Low Gain Mode
- 4.6-dB LNA Noise Figure, including T/R Switch and external antenna match
- RoHS Compliant 4x4-mm QFN-16 Package
- 2.0-V to 3.6-V Operation

APPLICATIONS

- All 2.4-GHz ISM Band Systems
- Wireless Sensor Networks
- Wireless Industrial Systems
- IEEE 802.15.4 and ZigBee Systems
- Wireless Consumer Systems
- Wireless Audio Systems

DESCRIPTION

CC2590 is a cost-effective and high performance RF Front End for low-power and low-voltage 2.4-GHz wireless applications.

CC2590 is a range extender for all existing and future 2.4-GHz low-power RF transceivers, transmitters and System-on-Chip products from Texas Instruments.

CC2590 increases the link budget by providing a power amplifier for increased output power, and an LNA with low noise figure for improved receiver sensitivity.

CC2590 provides a small size, high output power RF design with its 4x4-mm QFN-16 package.

CC2590 contains PA, LNA, switches, RF-matching, and balun for simple design of high performance wireless applications.

CC2590 BLOCK DIAGRAM

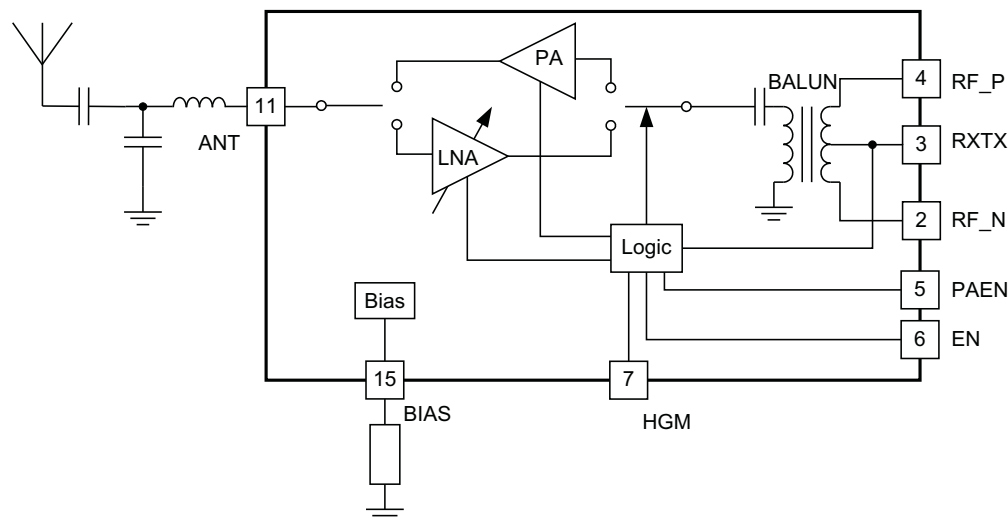

Please be aware that an important notice concerning availability, standard warranty, and use in critical applications of Texas Instruments semiconductor products and disclaimers thereto appears at the end of this data sheet.



These devices have limited built-in ESD protection. The leads should be shorted together or the device placed in conductive foam during storage or handling to prevent electrostatic damage to the MOS gates.

ABSOLUTE MAXIMUM RATINGS

Under no circumstances must the absolute maximum ratings be violated. Stress exceeding one or more of the limiting values may cause permanent damage to the device.

PARAMETER		VALUE	UNIT
Supply voltage	All supply pins must have the same voltage	–0.3 to 3.6	V
Voltage on any digital pin		–0.3 to $V_{DD} + 0.3$, max 3.6	V
Input RF level		+10	dBm
Storage temperature range		–50 to 150	°C
Reflow soldering temperature	According to IPC/JEDEC J-STD-020	260	°C
ESD	Human Body Model, all pins except pin 10	2000	V
	Human Body Model, pin 10	1900	V
	Charged Device Model	1000	V

RECOMMENDED OPERATING CONDITIONS

The operating conditions for CC2590 are listed below.

PARAMETER		MIN	MAX	UNIT
Ambient temperature range		–40	85	°C
Operating supply voltage		2.0	3.6	V
Operating frequency range		2400	2483.5	MHz

ELECTRICAL CHARACTERISTICS

$T_C = 25^\circ\text{C}$, $V_{DD} = 3.0\text{V}$, $f_{RF} = 2440\text{MHz}$ (unless otherwise noted). Measured on CC2590EM reference design including external matching components.

PARAMETER	TEST CONDITIONS	MIN	TYP	MAX	UNIT
Receive current, High Gain Mode	HGM = 1		3.4	4.0	mA
Receive current, Low Gain Mode	HGM = 0		1.8	2.0	mA
Transmit current	$P_{IN} = 0.5\text{ dBm}$, $P_{OUT} = 12.2\text{ dBm}$		22.1		mA
	$P_{IN} = -3.5\text{ dBm}$, $P_{OUT} = 10.0\text{ dBm}$		16.8		mA
Transmit current	No input signal		8.0	10.0	mA
Power down current	EN = PAEN = 0		0.1	0.3	μA
High input level (control pins)	EN, PAEN, HGM, RXTX	1.3		V_{DD}	V
Low input level (control pins)	EN, PAEN, HGM, RXTX			0.3	V
Power down - Receive mode switching time			1.4		μs
Power down - Transmit mode switching time			0.8		μs
RF Receive					
Gain, High Gain Mode	HGM = 1		11.4		dB
Gain, Low Gain Mode	HGM = 0		0		dB
Gain variation, 2400 – 2483.5 MHz, High Gain Mode	HGM = 1		1.2		dB
Gain variation, 2.0V – 3.6V, High Gain Mode	HGM = 1		1.7		dB
Noise figure, High Gain Mode	HGM = 1, including internal T/R switch and external antenna match		4.6		dB
Input 1 dB compression, High Gain Mode	HGM = 1		–21		dBm

ELECTRICAL CHARACTERISTICS (continued)

$T_C = 25^\circ\text{C}$, $V_{DD} = 3.0\text{V}$, $f_{RF} = 2440\text{MHz}$ (unless otherwise noted). Measured on CC2590EM reference design including external matching components.

PARAMETER	TEST CONDITIONS	MIN	TYP	MAX	UNIT
Input IP3, High Gain Mode	HGM = 1		-9		dBm
Input reflection coefficient, S11	HGM = 1, measured at antenna port		-19		dB
RF Transmit					
Gain			14.1		dB
Output power, P_{OUT}	$P_{IN} = 4.5\text{ dBm}$		13.8		dBm
	$P_{IN} = 0.5\text{ dBm}$		12.2		dBm
	$P_{IN} = -3.5\text{ dBm}$		10.0		dBm
Power Added Efficiency, PAE	$P_{IN} = 0.5\text{ dBm}$		23.5		%
Output 1 dB compression			10.4		dBm
Output IP3			23		dBm
Output power variation over frequency	2400 – 2483.5 MHz, $P_{IN} = 0.5\text{ dBm}$		0.3		dB
Output power variation over power supply	2.0V – 3.6V, $P_{IN} = 0.5\text{ dBm}$		3.2		dB
Output power variation over temperature	-40°C – 85°C, $P_{IN} = 0.5\text{ dBm}$		1.1		dB
2nd harmonic power	The 2nd harmonic can be reduced to below regulatory limits by using an external LC filter and antenna. See application note AN032 for regulatory requirements.		-14		dBm
3rd harmonic power	The 3rd harmonic can be reduced to below regulatory limits by using an external LC filter and antenna. See application note AN032 for regulatory requirements.		-28		dBm

DEVICE INFORMATION

The CC2590 pinout and description are shown in Figure 1 and Table 1, respectively.

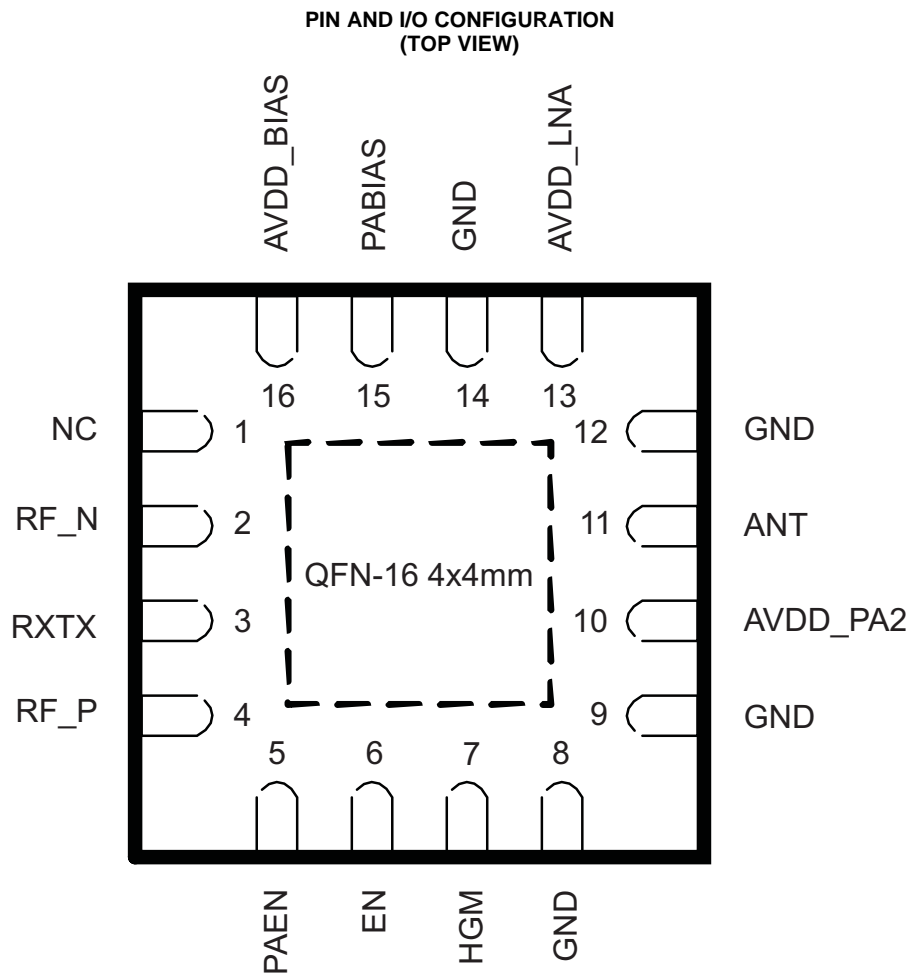

Figure 1.

NOTE:

The exposed die attach pad **must** be connected to a solid ground plane as this is the primary ground connection for the chip. Inductance in vias to the pad should be minimized. It is highly recommended to follow the reference layout. Changes will alter the performance. Also see the PCB landpattern information in this data sheet.

For best performance, minimize the length of the ground vias, by using a 4-layer PCB with ground plane as layer 2 when CC2590 is mounted onto layer 1.

Table 1. PIN FUNCTIONS

PIN		TYPE	DESCRIPTION
NO.	NAME		
—	GND	Ground	The exposed die attach pad must be connected to a solid ground plane. See CC2590EM reference design for recommended layout.
1	NC		Not Connected
2	RF_N	RF	RF interface towards CC24xx or CC25xx device.
3	RXTX	Analog/Control	RXTX switching voltage when connected to CC24xx devices. See Table 3 , Table 4 , and Table 5 for details.
4	RF_P	RF	RF interface towards CC24xx or CC25xx device
5	PAEN	Digital Input	Digital control pin. See Table 3 , Table 4 , and Table 5 for details.
6	EN	Digital Input	Digital control pin. See Table 3 , Table 4 , and Table 5 for details.
7	HGM	Digital Input	Digital control pin. HGM=1 → Device in High Gain Mode HGM=0 → Device in Low Gain Mode (RX only)
8, 9, 12, 14	GND	Ground	Secondary ground connections. Should be shorted to the die attach pad on the top PCB layer.
10	AVDD_PA2	Power	2.0-V – 3.6-V Power. PCB trace to this pin serves as inductive load to PA. See CC2590EM reference design for recommended layout.
11	ANT	RF	Antenna interface.
13	AVDD_LNA	Power	2.0-V – 3.6-V Power. PCB trace to this pin serves as inductive load to LNA. See CC2590EM reference design for recommended layout.
15	BIAS	Analog	Biasing input. Resistor between this node and ground sets bias current to PAs.
16	AVDD_BIAS	Power	2.0-V – 3.6-V Power.

CC2590EM Evaluation Module

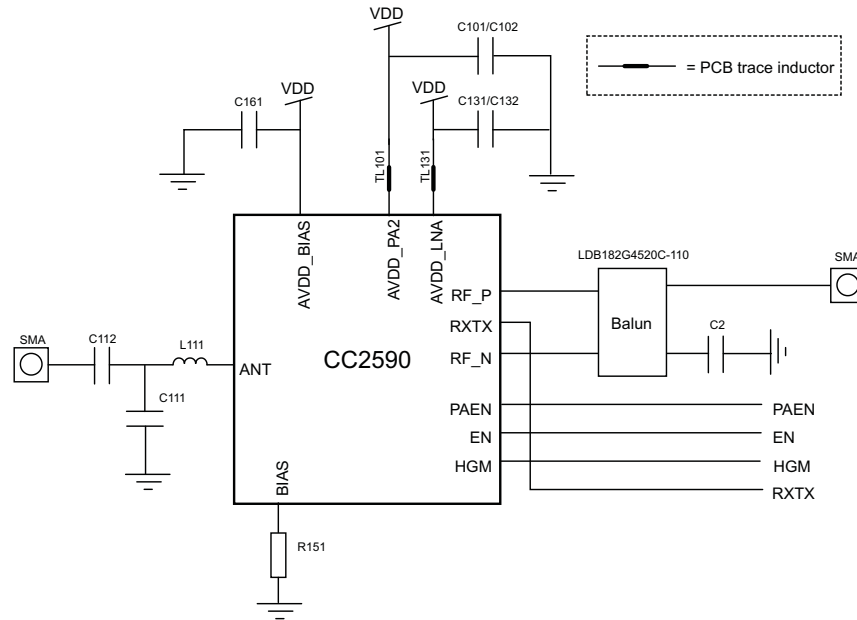

Figure 2. CC2590EM Evaluation Module

Table 2. List of Materials (See CC2590EM Reference Design)

DEVICE	FUNCTION	VALUE
L112	Part of antenna match.	1.5 nH: LQW15AN1N5B00 from Murata
C111	Part of antenna match.	0.5 pF, GRM1555C1HR50BZ01 from Murata
C112	DC block.	47 pF, GRM1555C1H470JZ01 from Murata
C161	Decoupling capacitor.	1 nF: GRM1555C1H102JA01 from Murata
C101/C102	Decoupling. Will affect PA resonance. See CC2590EM reference design for placement.	27 pF 1 nF. The smallest cap closest to CC2590. 27 pF: GRM1555C1H270JZ01 from Murata 1 nF: GRM1555C1H102JA01 from Murata
C131/C132	Decoupling. Will affect LNA resonance. See CC2590EM reference design for placement.	18 pF 1 nF. The smallest cap closest to CC2590. 18 pF: GRM1555C1H180JZ01 from Murata 1 nF: GRM1555C1H102JA01 from Murata
C2	Decoupling of external balun	1 nF: LWQ15AN1N5B00 from Murata
TL101 ⁽¹⁾	Transmission line. Will affect PA resonance. (simulated inductance: 0.87nH)	See CC2590EM reference design. Transmission line: Length ≈ 40 mil, Width = 8 mil
TL131	Transmission line. Will affect LNA resonance. (simulated inductance: 1.64nH)	See CC2590EM reference design. Transmission line: Length ≈ 100 mil, Width = 8 mil
R151	Bias resistor	4.3 kΩ: RK73H1ETTP4301F from Koa

(1) Transmission lines are measured from edge of pad of the CC2590 footprint to edge of pad of DC coupling capacitor. The length of the transmission lines depend on the distance to the ground plane. If another PCB stack up is chosen the length of the transmission lines needs to be adjusted.

PCB description: 4 layer PCB 1.6mm

- Copper 1: 35 μm
- Dielectric 1-2: 0.35 mm (e.g. 2x Prepreg 7628 AT05 47% Resin)
- Copper 2: 18 μm
- Dielectric 2-3: 0.76 mm (4 x 7628M 43% Resin)
- Copper 3: 18 μm
- Dielectric 3-4: 0.35 mm (e.g. 2x Prepreg 7628 AT05 47% Resin)
- Copper 4: 35 μm

DE104iML or equivalent substrate (Resin contents around 45%, which gives Er=4.42 at 2.4GHz, TanD=0.016)

TYPICAL CHARACTERISTICS

LNA GAIN AND NOISE FIGURE
VS
FREQUENCY

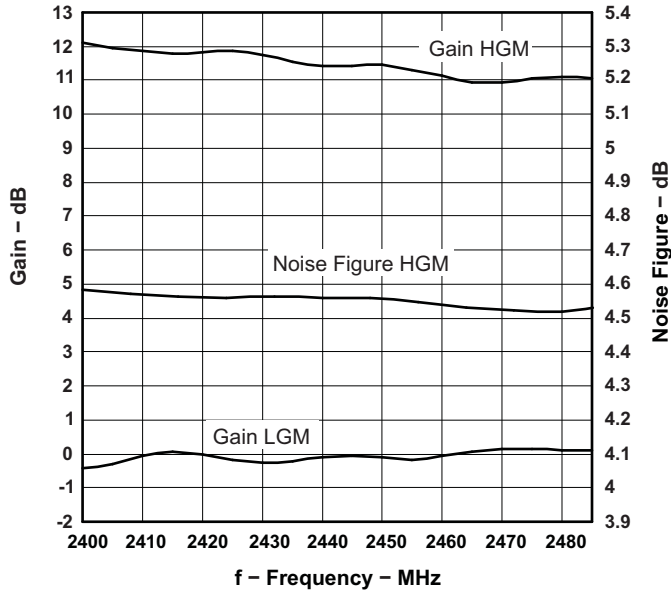

Figure 3.

LNA GAIN
VS
TEMPERATURE

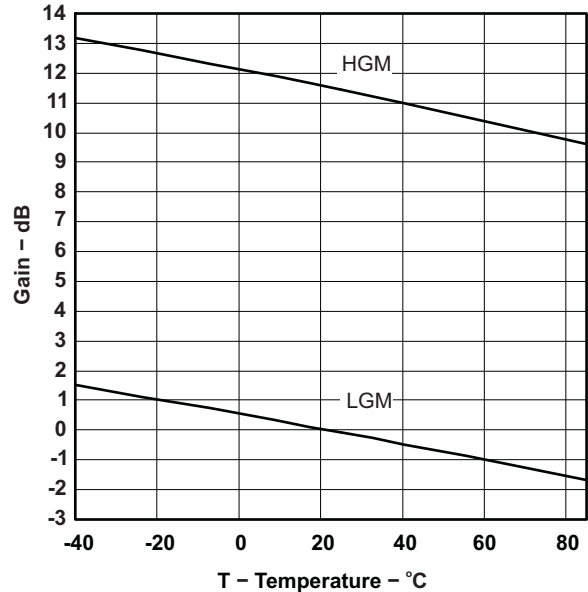

Figure 4.

LNA GAIN
VS
POWER SUPPLY

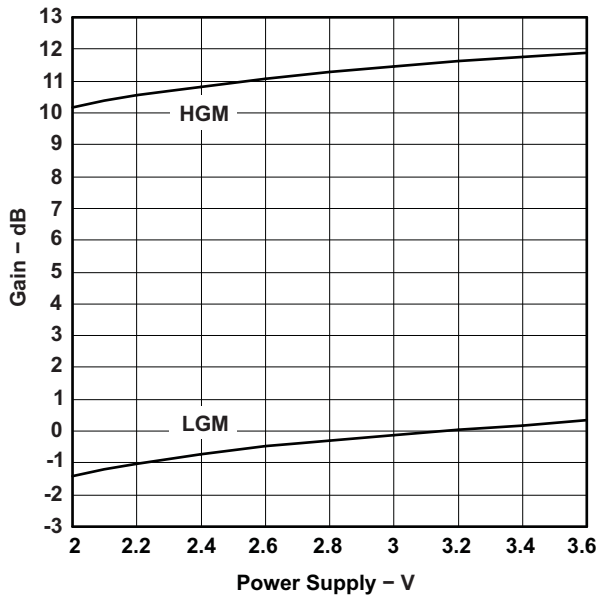

Figure 5.

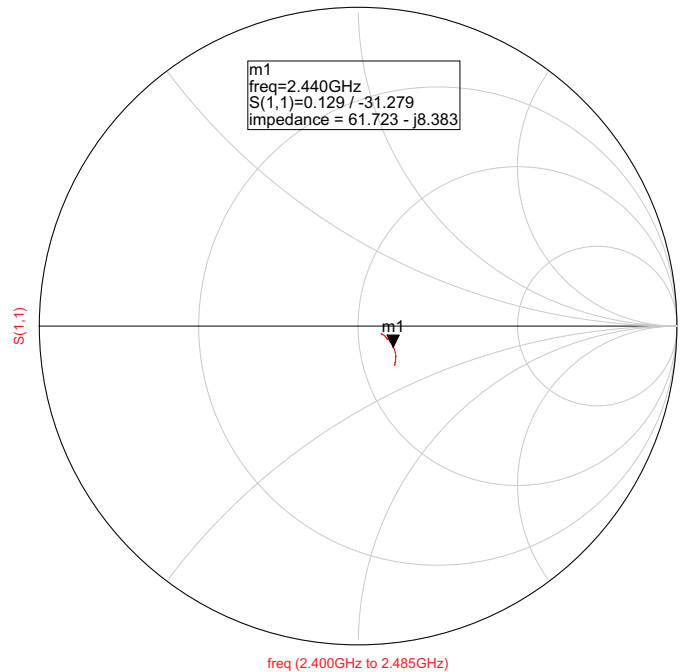

Figure 6. Input Impedance of LNA Measured from Antenna Port on CC2590EM

TYPICAL CHARACTERISTICS (continued)

OUTPUT POWER, PAE AND CURRENT CONSUMPTION VS INPUT POWER

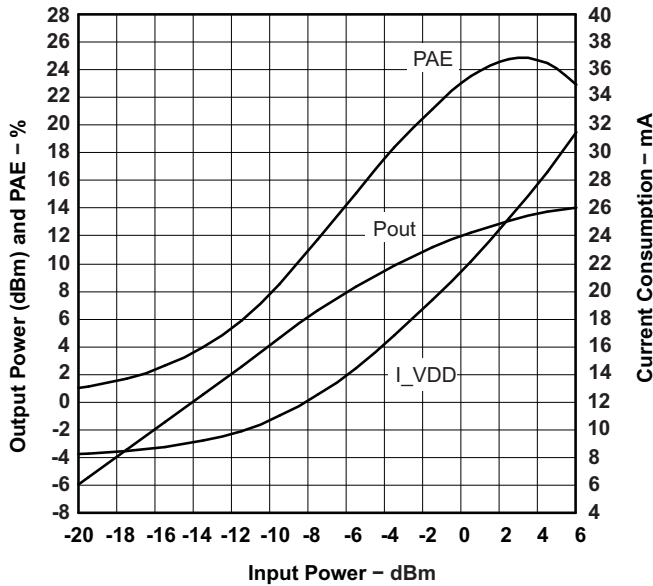

Figure 7.

OUTPUT POWER, PAE AND CURRENT CONSUMPTION VS FREQUENCY

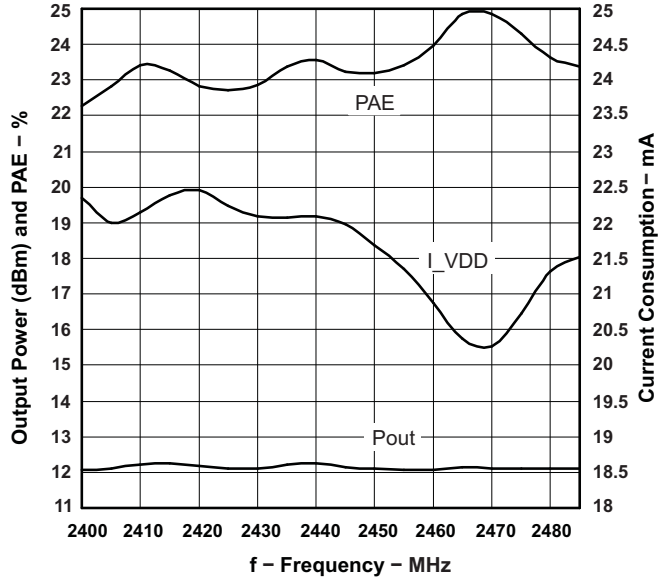

Figure 8.

OUTPUT POWER, PAE AND CURRENT CONSUMPTION VS TEMPERATURE

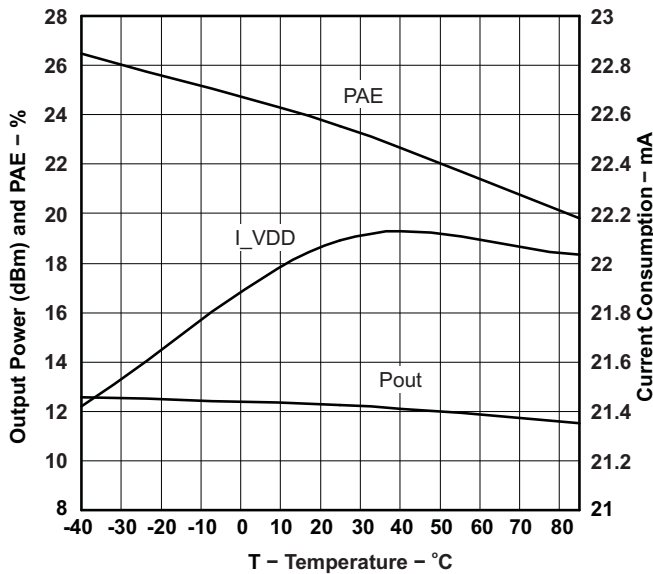

Figure 9.

OUTPUT POWER, PAE AND CURRENT CONSUMPTION VS POWER SUPPLY

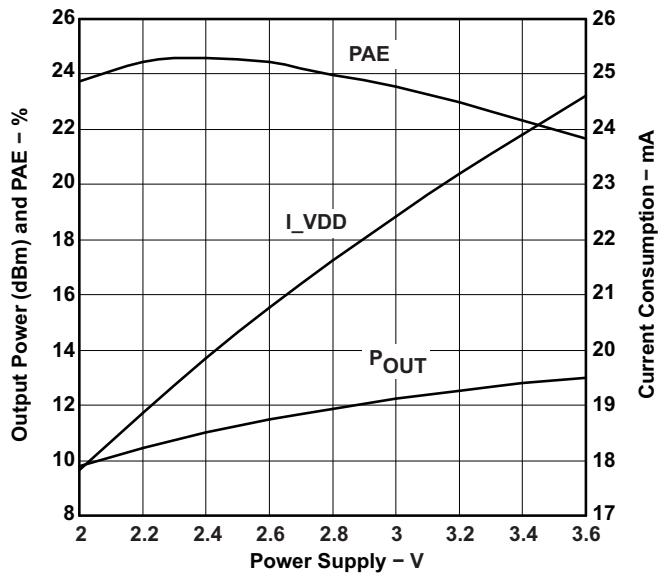

Figure 10.

Controlling the Output Power from CC2590

The output power of CC2590 is controlled by controlling the input power. The CC2590 PA is designed to work in compression (class AB), and the best efficiency is reached when a strong input signal is applied.

Input Levels on Control Pins

The four digital control pins (PAEN, EN, HGM, RXTX) have built-in level-shifting functionality, meaning that if the CC2590 is operating from a 3.6-V supply voltage, the control pins will still sense 1.6-V - 1.8-V signals as logical '1'.

An example of the above would be that RXTX is connected directly to the RXTX pin on CC24xx, but the global supply voltage is 3.6-V. The RXTX pin on CC24xx will switch between 0-V (RX) and 1.8-V(TX), which is still a high enough voltage to control the mode of CC2590.

The input voltages should however not have logical '1' level that is higher than the supply.

Connecting CC2590 to a CC24xx Device

Table 3. Control Logic for Connecting CC2590 to a CC24xx Device

PAEN = EN	RXTX	HGM	MODE OF OPERATION
0	X	X	Power Down
1	0	0	RX Low Gain Mode
1	0	1	RX High Gain Mode
1	1	X	TX

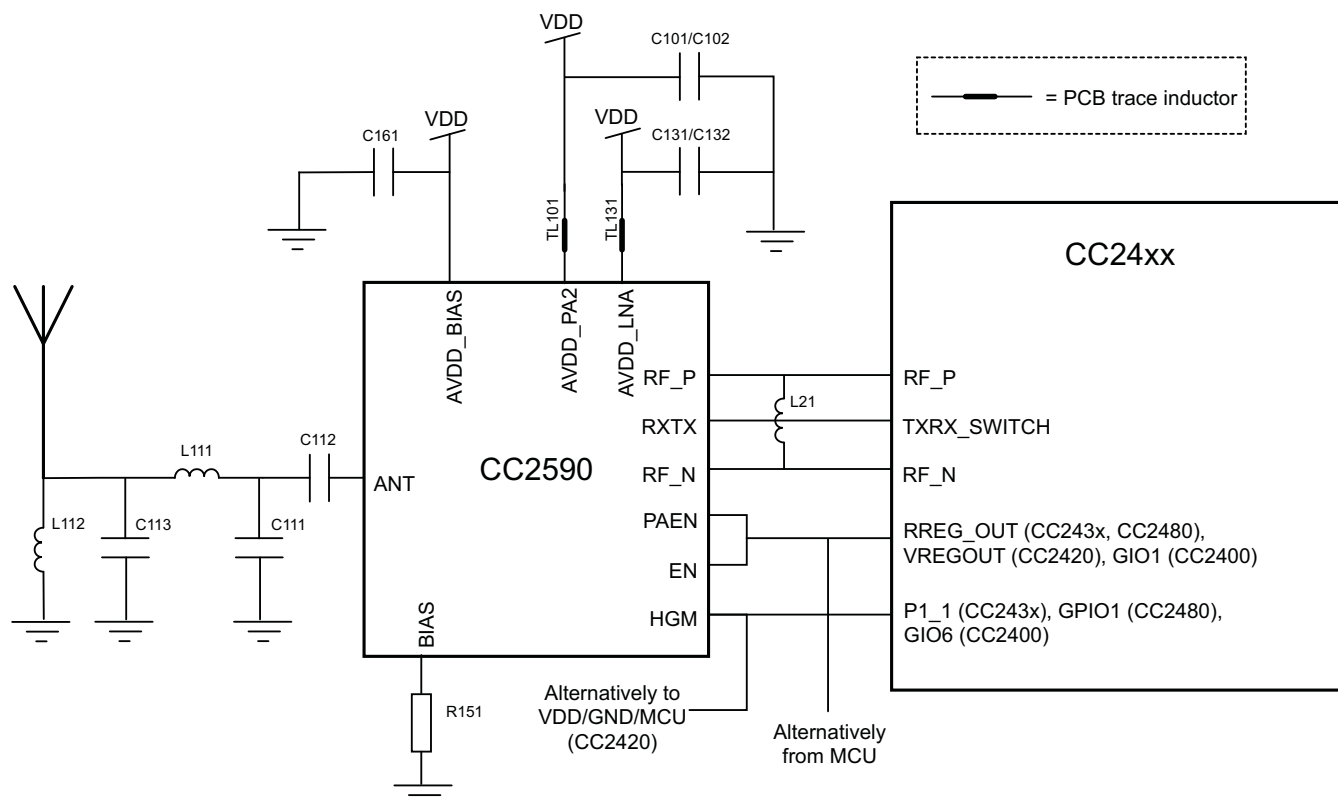

Figure 11. CC2590 + CC24xx Application Circuit

Connecting CC2590 to the CC2500, CC2510, or CC2511 Device

Table 4. Control Logic for Connecting CC2590 to a CC2500/10/11 Devices

PAEN	EN	RXTX	HGM	MODE OF OPERATION
0	0	NC	X	Power Down
0	1	NC	0	RX Low Gain Mode
0	1	NC	1	RX High Gain Mode
1	0	NC	X	TX
1	1	NC	X	Not allowed

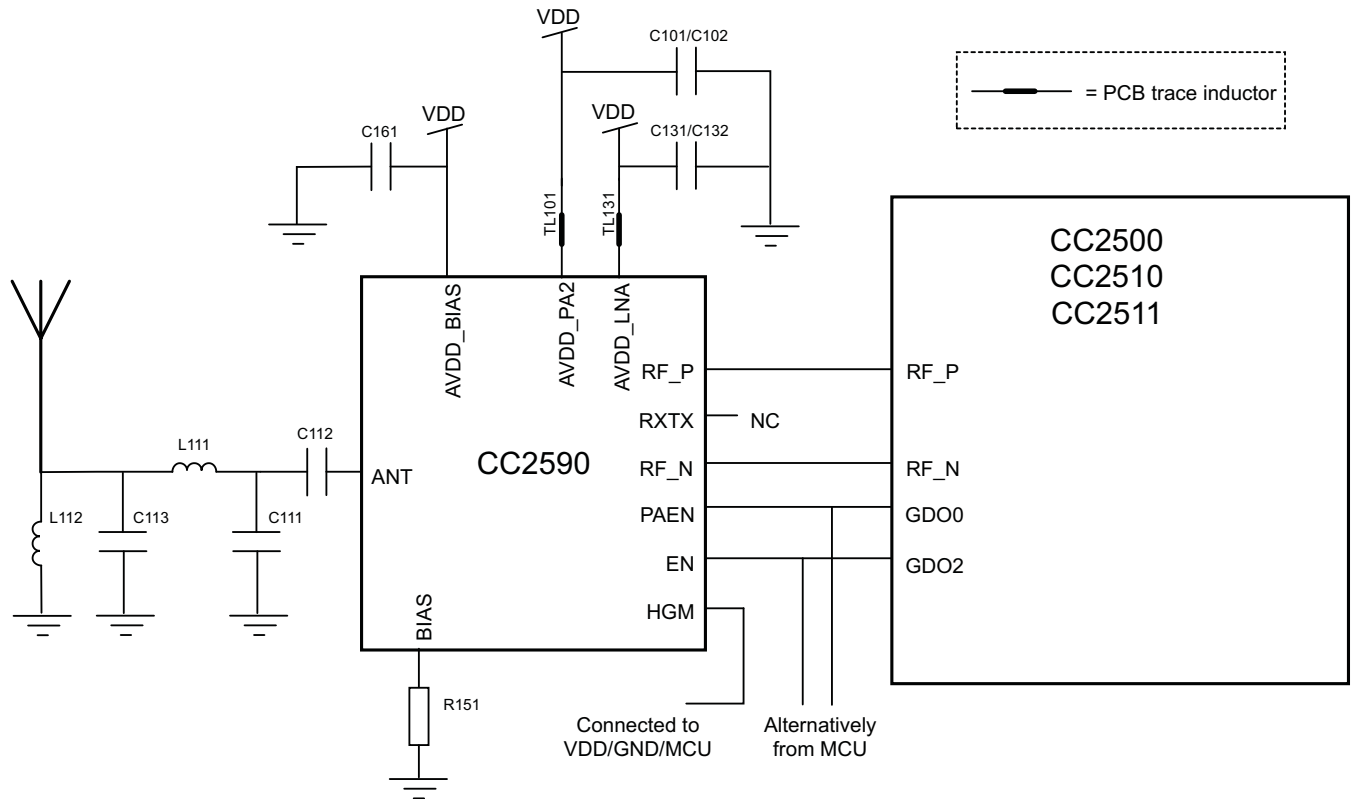

Figure 12. CC2590 + CC2500/10/11 Device Application Circuit

Connecting CC2590 to a CC2520 Device

Table 5. Control Logic for Connecting CC2590 to a CC2520 Device

PAEN	EN	RXTX	HGM	MODE OF OPERATION
0	0	NC	X	Power Down
0	1	NC	0	RX Low Gain Mode
0	1	NC	1	RX High Gain Mode
1	0	NC	X	TX
1	1	NC	X	Not allowed

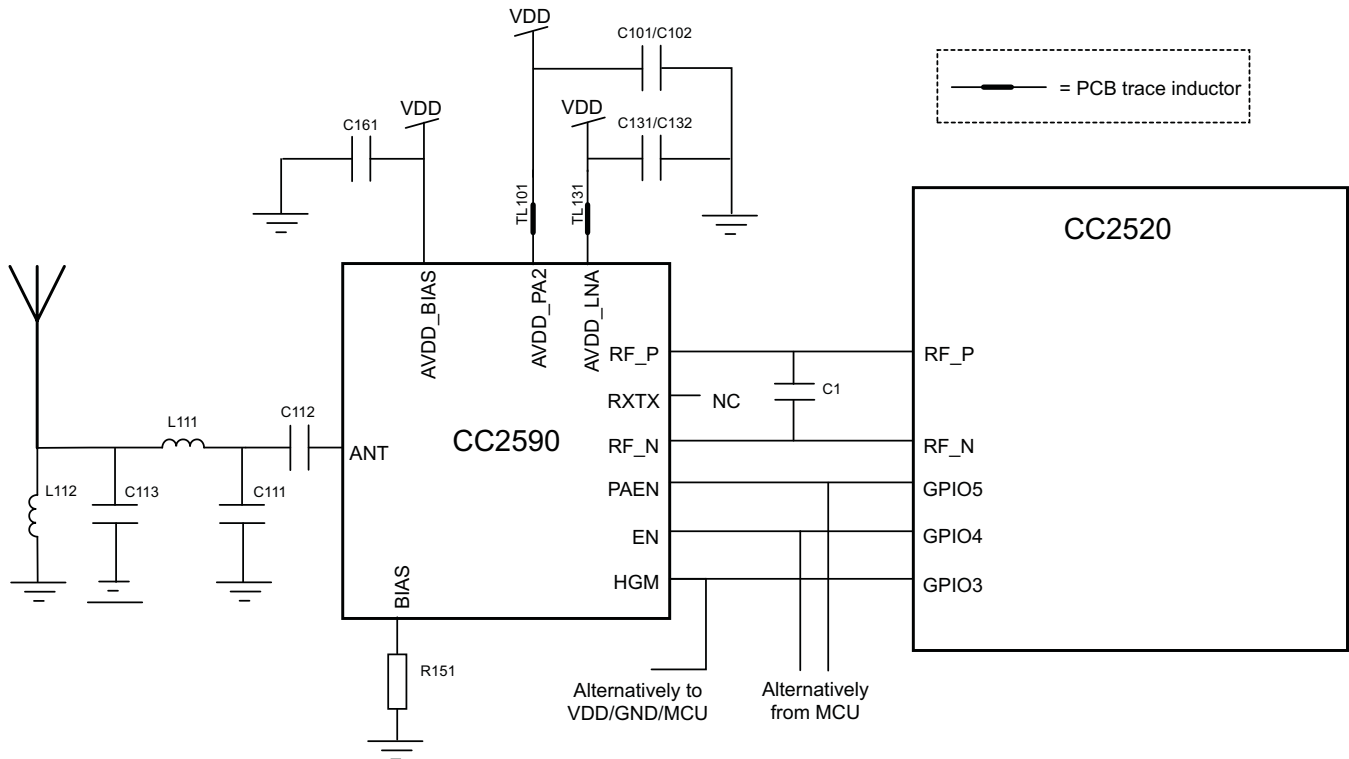

Figure 13. CC2590 + CC2520 Application Circuit

PCB Layout Guidelines

The exposed die attach pad must be connected to a solid ground plane as this is the primary ground connection for the chip. Inductance in vias to the pad should be minimized. It is highly recommended to follow the reference layout. Changes will alter the performance. Also see the PCB landpattern information in this data sheet. For best performance, minimize the length of the ground vias, by using a 4-layer PCB with ground plane as layer 2 when CC2590 is mounted onto layer 1.

PCB trace inductors are used to be able to optimize the inductance value, and they are too small to be replaced by discrete inductors. The placement of the power supply decoupling capacitors C101/C102 and C131/C132 are important to set the PCB trace inductance values accurately.

PACKAGING INFORMATION

Orderable Device	Status (1)	Package Type	Package Drawing	Pins	Package Qty	Eco Plan (2)	Lead/Ball Finish (6)	MSL Peak Temp (3)	Op Temp (°C)	Device Marking (4/5)	Samples
CC2590RGVR	ACTIVE	VQFN	RGV	16	2500	Green (RoHS & no Sb/Br)	CU NIPDAU	Level-2-260C-1 YEAR	-40 to 85	CC2590	Samples
CC2590RGVRG4	ACTIVE	VQFN	RGV	16	2500	Green (RoHS & no Sb/Br)	CU NIPDAU	Level-2-260C-1 YEAR	-40 to 85	CC2590	Samples
CC2590RGVT	ACTIVE	VQFN	RGV	16	250	Green (RoHS & no Sb/Br)	CU NIPDAU Call TI	Level-2-260C-1 YEAR	-40 to 85	CC2590	Samples

(1) The marketing status values are defined as follows:

ACTIVE: Product device recommended for new designs.

LIFEBUY: TI has announced that the device will be discontinued, and a lifetime-buy period is in effect.

NRND: Not recommended for new designs. Device is in production to support existing customers, but TI does not recommend using this part in a new design.

PREVIEW: Device has been announced but is not in production. Samples may or may not be available.

OBsolete: TI has discontinued the production of the device.

(2) **RoHS:** TI defines "RoHS" to mean semiconductor products that are compliant with the current EU RoHS requirements for all 10 RoHS substances, including the requirement that RoHS substance do not exceed 0.1% by weight in homogeneous materials. Where designed to be soldered at high temperatures, "RoHS" products are suitable for use in specified lead-free processes. TI may reference these types of products as "Pb-Free".

RoHS Exempt: TI defines "RoHS Exempt" to mean products that contain lead but are compliant with EU RoHS pursuant to a specific EU RoHS exemption.

Green: TI defines "Green" to mean the content of Chlorine (Cl) and Bromine (Br) based flame retardants meet JS709B low halogen requirements of <=1000ppm threshold. Antimony trioxide based flame retardants must also meet the <=1000ppm threshold requirement.

(3) MSL, Peak Temp. - The Moisture Sensitivity Level rating according to the JEDEC industry standard classifications, and peak solder temperature.

(4) There may be additional marking, which relates to the logo, the lot trace code information, or the environmental category on the device.

(5) Multiple Device Markings will be inside parentheses. Only one Device Marking contained in parentheses and separated by a "-" will appear on a device. If a line is indented then it is a continuation of the previous line and the two combined represent the entire Device Marking for that device.

(6) Lead/Ball Finish - Orderable Devices may have multiple material finish options. Finish options are separated by a vertical ruled line. Lead/Ball Finish values may wrap to two lines if the finish value exceeds the maximum column width.

Important Information and Disclaimer:The information provided on this page represents TI's knowledge and belief as of the date that it is provided. TI bases its knowledge and belief on information provided by third parties, and makes no representation or warranty as to the accuracy of such information. Efforts are underway to better integrate information from third parties. TI has taken and continues to take reasonable steps to provide representative and accurate information but may not have conducted destructive testing or chemical analysis on incoming materials and chemicals. TI and TI suppliers consider certain information to be proprietary, and thus CAS numbers and other limited information may not be available for release.

In no event shall TI's liability arising out of such information exceed the total purchase price of the TI part(s) at issue in this document sold by TI to Customer on an annual basis.

TAPE AND REEL INFORMATION



QUADRANT ASSIGNMENTS FOR PIN 1 ORIENTATION IN TAPE



*All dimensions are nominal

Device	Package Type	Package Drawing	Pins	SPQ	Reel Diameter (mm)	Reel Width W1 (mm)	A0 (mm)	B0 (mm)	K0 (mm)	P1 (mm)	W (mm)	Pin1 Quadrant
CC2590RGVR	VQFN	RGV	16	2500	330.0	12.4	4.3	4.3	1.5	8.0	12.0	Q2
CC2590RGVT	VQFN	RGV	16	250	180.0	12.4	4.3	4.3	1.5	8.0	12.0	Q2

TAPE AND REEL BOX DIMENSIONS

*All dimensions are nominal

Device	Package Type	Package Drawing	Pins	SPQ	Length (mm)	Width (mm)	Height (mm)
CC2590RGVR	VQFN	RGV	16	2500	350.0	350.0	43.0
CC2590RGVT	VQFN	RGV	16	250	210.0	185.0	35.0

RGV (S-PVQFN-N16)

PLASTIC QUAD FLATPACK NO-LEAD

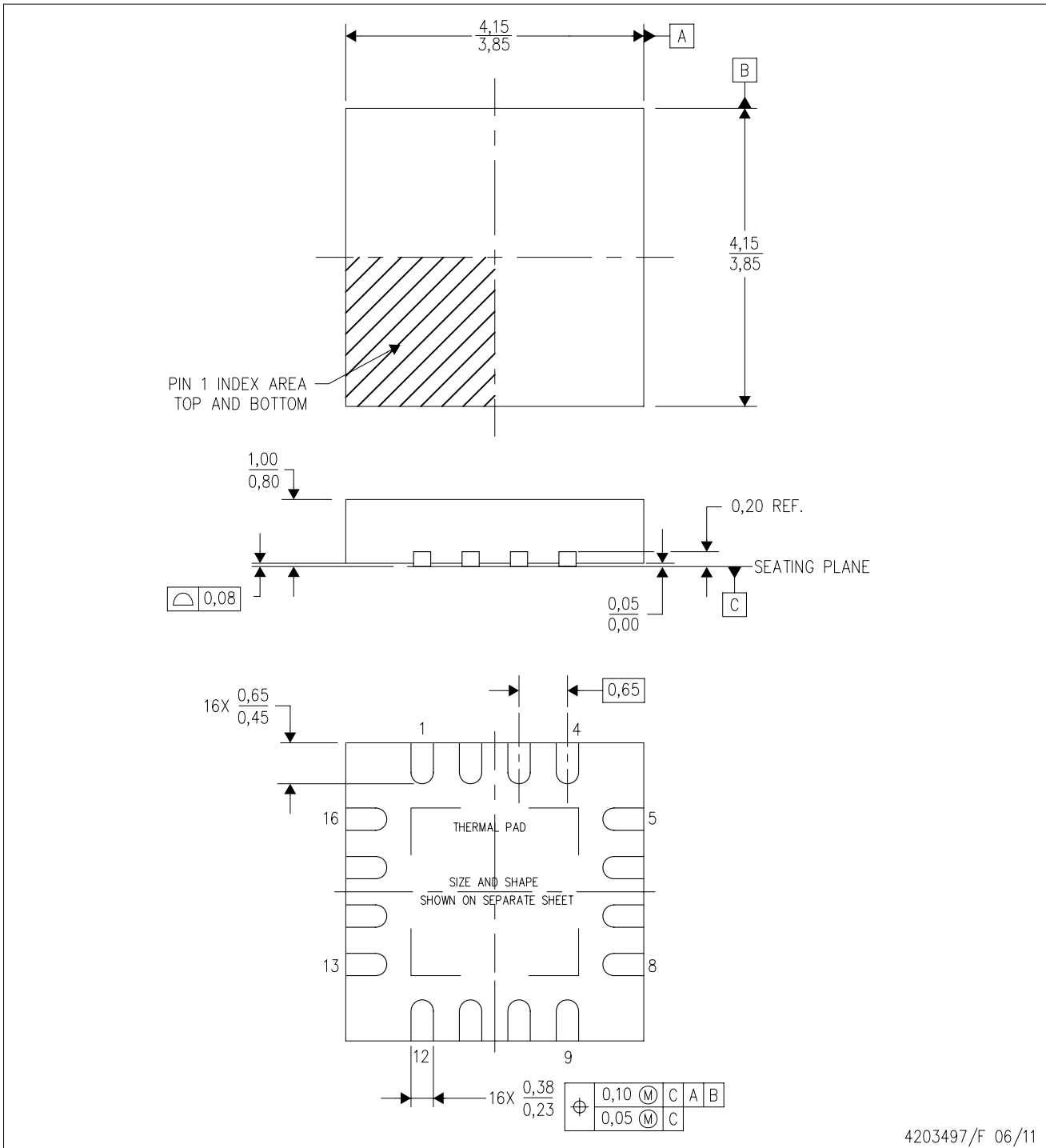

4203497/F 06/11

- NOTES:
- A. All linear dimensions are in millimeters. Dimensioning and tolerancing per ASME Y14.5M-1994.
 - B. This drawing is subject to change without notice.
 - C. Quad Flatpack, No-leads (QFN) package configuration.
 - D. The package thermal pad must be soldered to the board for thermal and mechanical performance.
 - E. See the additional figure in the Product Data Sheet for details regarding the exposed thermal pad features and dimensions.
 - F. Falls within JEDEC MO-220.

THERMAL PAD MECHANICAL DATA

RGV (S-PVQFN-N16)

PLASTIC QUAD FLATPACK NO-LEAD

THERMAL INFORMATION

This package incorporates an exposed thermal pad that is designed to be attached directly to an external heatsink. The thermal pad must be soldered directly to the printed circuit board (PCB). After soldering, the PCB can be used as a heatsink. In addition, through the use of thermal vias, the thermal pad can be attached directly to the appropriate copper plane shown in the electrical schematic for the device, or alternatively, can be attached to a special heatsink structure designed into the PCB. This design optimizes the heat transfer from the integrated circuit (IC).

For information on the Quad Flatpack No-Lead (QFN) package and its advantages, refer to Application Report, QFN/SON PCB Attachment, Texas Instruments Literature No. SLUA271. This document is available at www.ti.com.

The exposed thermal pad dimensions for this package are shown in the following illustration.

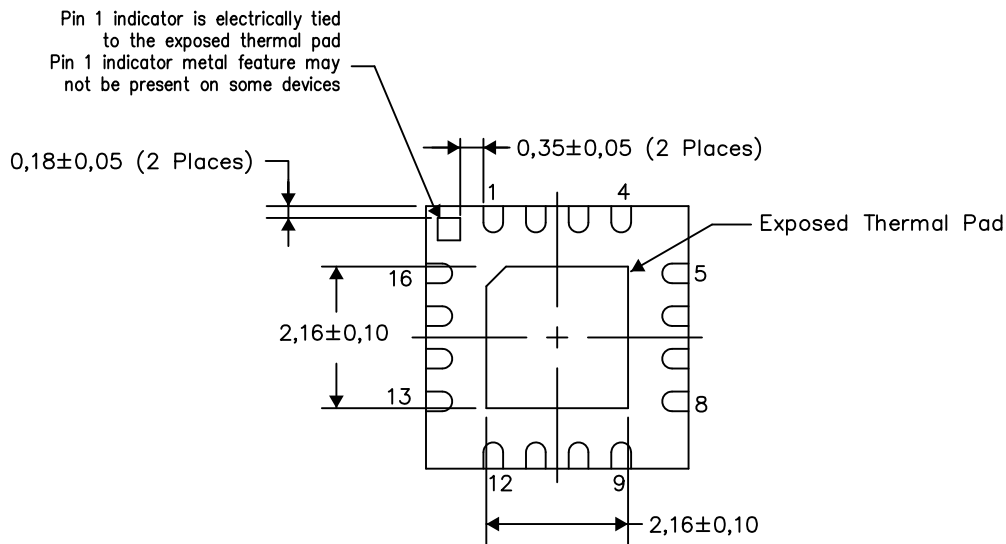

Bottom View

Exposed Thermal Pad Dimensions

4206351-2/L 05/13

NOTE: All linear dimensions are in millimeters

RGV (S-PVQFN-N16)

PLASTIC QUAD FLATPACK NO-LEAD

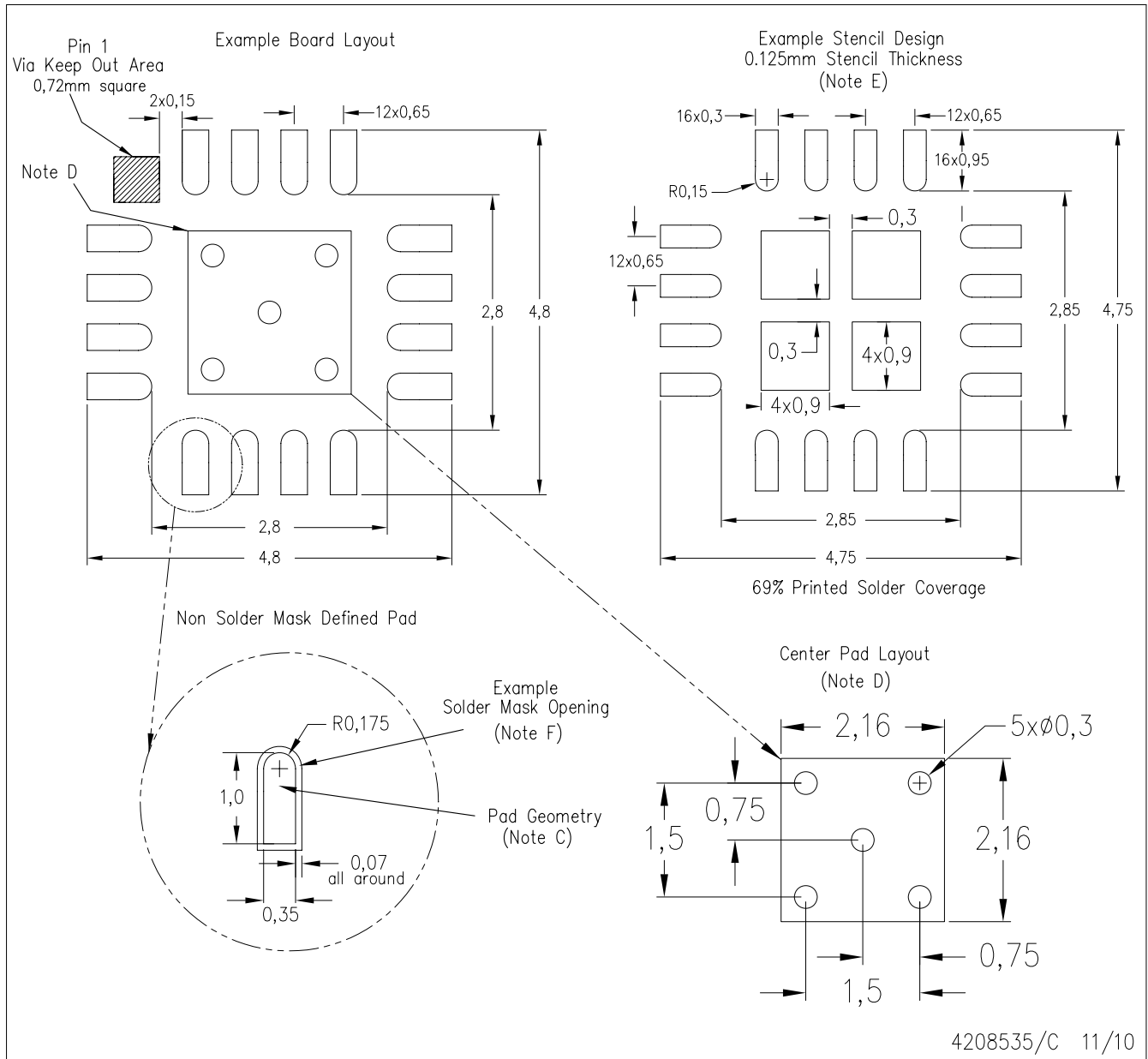

- NOTES:
- All linear dimensions are in millimeters.
 - This drawing is subject to change without notice.
 - Publication IPC-7351 is recommended for alternate designs.
 - This package is designed to be soldered to a thermal pad on the board. Refer to Application Note, QFN Packages, Texas Instruments Literature No. SLUA271, and also the Product Data Sheets for specific thermal information, via requirements, and recommended board layout. These documents are available at www.ti.com <<http://www.ti.com>>.
 - Laser cutting apertures with trapezoidal walls and also rounding corners will offer better paste release. Customers should contact their board assembly site for stencil design recommendations. Refer to IPC 7525 for stencil design considerations.
 - Customers should contact their board fabrication site for solder mask tolerances.

IMPORTANT NOTICE AND DISCLAIMER

TI PROVIDES TECHNICAL AND RELIABILITY DATA (INCLUDING DATASHEETS), DESIGN RESOURCES (INCLUDING REFERENCE DESIGNS), APPLICATION OR OTHER DESIGN ADVICE, WEB TOOLS, SAFETY INFORMATION, AND OTHER RESOURCES "AS IS" AND WITH ALL FAULTS, AND DISCLAIMS ALL WARRANTIES, EXPRESS AND IMPLIED, INCLUDING WITHOUT LIMITATION ANY IMPLIED WARRANTIES OF MERCHANTABILITY, FITNESS FOR A PARTICULAR PURPOSE OR NON-INFRINGEMENT OF THIRD PARTY INTELLECTUAL PROPERTY RIGHTS.

These resources are intended for skilled developers designing with TI products. You are solely responsible for (1) selecting the appropriate TI products for your application, (2) designing, validating and testing your application, and (3) ensuring your application meets applicable standards, and any other safety, security, or other requirements. These resources are subject to change without notice. TI grants you permission to use these resources only for development of an application that uses the TI products described in the resource. Other reproduction and display of these resources is prohibited. No license is granted to any other TI intellectual property right or to any third party intellectual property right. TI disclaims responsibility for, and you will fully indemnify TI and its representatives against, any claims, damages, costs, losses, and liabilities arising out of your use of these resources.

TI's products are provided subject to TI's Terms of Sale (www.ti.com/legal/termsofsale.html) or other applicable terms available either on ti.com or provided in conjunction with such TI products. TI's provision of these resources does not expand or otherwise alter TI's applicable warranties or warranty disclaimers for TI products.

Mailing Address: Texas Instruments, Post Office Box 655303, Dallas, Texas 75265
Copyright © 2019, Texas Instruments Incorporated

Looking for pricing, stock, or lifecycle information?

Click below to explore more details on WIN SOURCE:

 [View CC2590](#) on WIN SOURCE

 [Texas Instruments](#) Information

Optimize Your Supply Chain with WIN SOURCE Solutions

-  Global Sourcing Solution
-  Obsolete Management
-  Cost Control Management
-  Shortage Management
-  Alternative Solution
-  Excess Inventory Management