



**THE DATASHEET OF  
CC2430ZF128RTCR**



A True System-on-Chip solution for 2.4 GHz IEEE 802.15.4 / ZigBee®

Applications

- 2.4 GHz IEEE 802.15.4 systems
- ZigBee® systems
- Home/building automation
- Industrial Control and Monitoring

- Low power wireless sensor networks
- PC peripherals
- Set-top boxes and remote controls
- Consumer Electronics

Product Description

The CC2430 comes in three different flash versions: CC2430F32/64/128, with 32/64/128 KB of flash memory respectively. The CC2430 is a true System-on-Chip (SoC) solution specifically tailored for IEEE 802.15.4 and ZigBee® applications. It enables ZigBee® nodes to be built with very low total bill-of-material costs. The CC2430 combines the excellent performance of the leading CC2420 RF transceiver with an industry-standard enhanced 8051 MCU, 32/64/128 KB flash memory, 8 KB RAM and many other powerful features. Combined with the industry leading ZigBee® protocol stack (Z-Stack™) from Texas Instruments, the CC2430 provides the market's most competitive ZigBee® solution.

The CC2430 is highly suited for systems where ultra low power consumption is required. This is ensured by various operating modes. Short transition times between operating modes further ensure low power consumption.

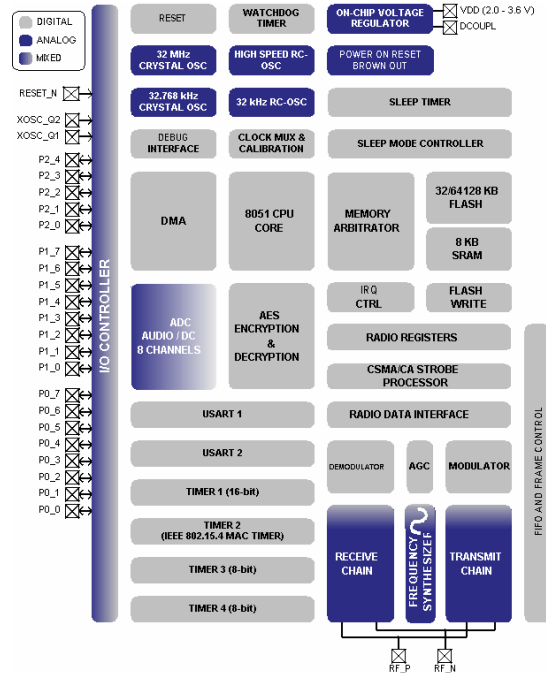

Key Features

- **RF/Layout**
  - 2.4 GHz IEEE 802.15.4 compliant RF transceiver (industry leading CC2420 radio core)
  - Excellent receiver sensitivity and robustness to interferers
  - Very few external components
  - Only a single crystal needed for mesh network systems
  - RoHS compliant 7x7mm QLP48 package
- **Low Power**
  - Low current consumption (RX: 27 mA, TX: 27 mA, microcontroller running at 32 MHz)
  - Only 0.5 µA current consumption in powerdown mode, where external interrupts or the RTC can wake up the system
  - 0.3 µA current consumption in stand-by mode, where external interrupts can wake up the system
  - Very fast transition times from low-power modes to active mode enables ultra low average power consumption in low dutycycle systems
  - Wide supply voltage range (2.0V - 3.6V)

- **Microcontroller**
  - High performance and low power 8051 microcontroller core
  - 32, 64 or 128 KB in-system programmable flash
  - 8 KB RAM, 4 KB with data retention in all power modes
  - Powerful DMA functionality
  - Watchdog timer
  - One IEEE 802.15.4 MAC timer, one general 16-bit timer and two 8-bit timers
  - Hardware debug support
- **Peripherals**
  - CSMA/CA hardware support.
  - Digital RSSI / LQI support
  - Battery monitor and temperature sensor
  - 12-bit ADC with up to eight inputs and configurable resolution
  - AES security coprocessor
  - Two powerful USARTs with support for several serial protocols
  - 21 general I/O pins, two with 20mA sink/source capability
- **Development tools**
  - Powerful and flexible development tools available

**Table Of Contents**

<b>1</b>	<b>ABBREVIATIONS</b> .....	<b>5</b>
<b>2</b>	<b>REFERENCES</b> .....	<b>7</b>
<b>3</b>	<b>REGISTER CONVENTIONS</b> .....	<b>8</b>
<b>4</b>	<b>FEATURES EMPHASIZED</b> .....	<b>9</b>
4.1	HIGH-PERFORMANCE AND LOW-POWER 8051-COMPATIBLE MICROCONTROLLER .....	9
4.2	UP TO 128 KB NON-VOLATILE PROGRAM MEMORY AND 2 X 4 KB DATA MEMORY .....	9
4.3	HARDWARE AES ENCRYPTION/DECRYPTION .....	9
4.4	PERIPHERAL FEATURES.....	9
4.5	LOW POWER.....	9
4.6	IEEE 802.15.4 MAC HARDWARE SUPPORT.....	9
4.7	INTEGRATED 2.4GHZ DSSS DIGITAL RADIO .....	9
<b>5</b>	<b>ABSOLUTE MAXIMUM RATINGS</b> .....	<b>10</b>
<b>6</b>	<b>OPERATING CONDITIONS</b> .....	<b>10</b>
<b>7</b>	<b>ELECTRICAL SPECIFICATIONS</b> .....	<b>11</b>
7.1	GENERAL CHARACTERISTICS .....	12
7.2	RF RECEIVE SECTION .....	13
7.3	RF TRANSMIT SECTION.....	13
7.4	32 MHz CRYSTAL OSCILLATOR.....	14
7.5	32.768 kHz CRYSTAL OSCILLATOR.....	14
7.6	32 kHz RC OSCILLATOR.....	15
7.7	16 MHz RC OSCILLATOR .....	15
7.8	FREQUENCY SYNTHESIZER CHARACTERISTICS .....	16
7.9	ANALOG TEMPERATURE SENSOR.....	16
7.10	ADC .....	16
7.11	CONTROL AC CHARACTERISTICS.....	18
7.12	SPI AC CHARACTERISTICS .....	19
7.13	DEBUG INTERFACE AC CHARACTERISTICS .....	20
7.14	PORT OUTPUTS AC CHARACTERISTICS .....	21
7.15	TIMER INPUTS AC CHARACTERISTICS.....	21
7.16	DC CHARACTERISTICS .....	21
<b>8</b>	<b>PIN AND I/O PORT CONFIGURATION</b> .....	<b>22</b>
<b>9</b>	<b>CIRCUIT DESCRIPTION</b> .....	<b>24</b>
9.1	CPU AND PERIPHERALS .....	25
9.2	RADIO .....	26
<b>10</b>	<b>APPLICATION CIRCUIT</b> .....	<b>27</b>
10.1	INPUT / OUTPUT MATCHING .....	27
10.2	BIAS RESISTORS .....	27
10.3	CRYSTAL.....	27
10.4	VOLTAGE REGULATORS .....	27
10.5	DEBUG INTERFACE.....	27
10.6	POWER SUPPLY DECOUPLING AND FILTERING.....	28
<b>11</b>	<b>8051 CPU</b> .....	<b>30</b>
11.1	8051 CPU INTRODUCTION .....	30
11.2	MEMORY.....	30
11.3	CPU REGISTERS.....	42
11.4	INSTRUCTION SET SUMMARY.....	44
11.5	INTERRUPTS .....	49
<b>12</b>	<b>DEBUG INTERFACE</b> .....	<b>60</b>
12.1	DEBUG MODE .....	60
12.2	DEBUG COMMUNICATION .....	60
12.3	DEBUG COMMANDS .....	60
12.4	DEBUG LOCK BIT.....	60
12.5	DEBUG INTERFACE AND POWER MODES .....	64
<b>13</b>	<b>PERIPHERALS</b> .....	<b>65</b>

13.1	POWER MANAGEMENT AND CLOCKS .....	65
13.2	RESET .....	71
13.3	FLASH CONTROLLER .....	71
13.4	I/O PORTS .....	77
13.5	DMA CONTROLLER .....	88
13.6	16-BIT TIMER, TIMER1 .....	99
13.7	MAC TIMER (TIMER2) .....	110
13.8	8-BIT TIMERS, TIMER 3 AND TIMER 4 .....	117
13.9	SLEEP TIMER .....	126
13.10	ADC .....	128
13.11	RANDOM NUMBER GENERATOR .....	134
13.12	AES COPROCESSOR .....	136
13.13	WATCHDOG TIMER .....	141
13.14	USART .....	143
<b>14</b>	<b>RADIO .....</b>	<b>153</b>
14.1	IEEE 802.15.4 MODULATION FORMAT .....	154
14.2	COMMAND STROBES .....	155
14.3	RF REGISTERS .....	155
14.4	INTERRUPTS .....	155
14.5	FIFO ACCESS .....	157
14.6	DMA .....	157
14.7	RECEIVE MODE .....	158
14.8	RXFIFO OVERFLOW .....	158
14.9	TRANSMIT MODE .....	159
14.10	GENERAL CONTROL AND STATUS .....	160
14.11	DEMODULATOR, SYMBOL SYNCHRONIZER AND DATA DECISION .....	160
14.12	FRAME FORMAT .....	161
14.13	SYNCHRONIZATION HEADER .....	161
14.14	LENGTH FIELD .....	162
14.15	MAC PROTOCOL DATA UNIT .....	162
14.16	FRAME CHECK SEQUENCE .....	162
14.17	RF DATA BUFFERING .....	163
14.18	ADDRESS RECOGNITION .....	164
14.19	ACKNOWLEDGE FRAMES .....	165
14.20	RADIO CONTROL STATE MACHINE .....	166
14.21	MAC SECURITY OPERATIONS (ENCRYPTION AND AUTHENTICATION) .....	168
14.22	LINEAR IF AND AGC SETTINGS .....	168
14.23	RSSI / ENERGY DETECTION .....	168
14.24	LINK QUALITY INDICATION .....	168
14.25	CLEAR CHANNEL ASSESSMENT .....	169
14.26	FREQUENCY AND CHANNEL PROGRAMMING .....	169
14.27	VCO AND PLL SELF-CALIBRATION .....	169
14.28	OUTPUT POWER PROGRAMMING .....	170
14.29	INPUT / OUTPUT MATCHING .....	170
14.30	TRANSMITTER TEST MODES .....	171
14.31	SYSTEM CONSIDERATIONS AND GUIDELINES .....	173
14.32	PCB LAYOUT RECOMMENDATION .....	175
14.33	ANTENNA CONSIDERATIONS .....	175
14.34	CSMA/CA STROBE PROCESSOR .....	176
14.35	RADIO REGISTERS .....	183
<b>15</b>	<b>VOLTAGE REGULATORS .....</b>	<b>202</b>
15.1	VOLTAGE REGULATORS POWER-ON .....	202
<b>16</b>	<b>EVALUATION SOFTWARE .....</b>	<b>202</b>
<b>17</b>	<b>REGISTER OVERVIEW .....</b>	<b>203</b>
<b>18</b>	<b>PACKAGE DESCRIPTION (QLP 48) .....</b>	<b>206</b>
18.1	RECOMMENDED PCB LAYOUT FOR PACKAGE (QLP 48) .....	207
18.2	PACKAGE THERMAL PROPERTIES .....	207
18.3	SOLDERING INFORMATION .....	207
18.4	TRAY SPECIFICATION .....	207

18.5	CARRIER TAPE AND REEL SPECIFICATION .....	207
<b>19</b>	<b>ORDERING INFORMATION.....</b>	<b>209</b>
<b>20</b>	<b>GENERAL INFORMATION.....</b>	<b>210</b>
20.1	DOCUMENT HISTORY .....	210
<b>21</b>	<b>ADDRESS INFORMATION .....</b>	<b>210</b>
<b>22</b>	<b>TI WORLDWIDE TECHNICAL SUPPORT .....</b>	<b>210</b>

## 1 Abbreviations

ADC	Analog to Digital Converter	I/O	Input / Output
AES	Advanced Encryption Standard	I/Q	In-phase / Quadrature-phase
AGC	Automatic Gain Control	IEEE	Institute of Electrical and Electronics Engineers
ARIB	Association of Radio Industries and Businesses	IF	Intermediate Frequency
BCD	Binary Coded Decimal	INL	Integral Nonlinearity
BER	Bit Error Rate	IOC	I/O Controller
BOD	Brown Out Detector	IRQ	Interrupt Request
BOM	Bill of Materials	ISM	Industrial, Scientific and Medical
CBC	Cipher Block Chaining	ITU-T	International Telecommunication Union – Telecommunication Standardization Sector
CBC-MAC	Cipher Block Chaining Message Authentication Code	IV	Initialization Vector
CCA	Clear Channel Assessment	JEDEC	Joint Electron Device Engineering Council
CCM	Counter mode + CBC-MAC	KB	1024 bytes
CFB	Cipher Feedback	kbps	kilo bits per second
CFR	Code of Federal Regulations	LC	Inductor-capacitor
CMOS	Complementary Metal Oxide Semiconductor	LFSR	Linear Feedback Shift Register
CMRR	Common Mode Ratio Rejection	LNA	Low-Noise Amplifier
CPU	Central Processing Unit	LO	Local Oscillator
CRC	Cyclic Redundancy Check	LQI	Link Quality Indication
CSMA-CA	Carrier Sense Multiple Access with Collision Avoidance	LSB	Least Significant Bit / Byte
CSP	CSMA/CA Strobe Processor	LSB	Least Significant Byte
CTR	Counter mode (encryption)	MAC	Medium Access Control
CW	Continuous Wave	MAC	Message Authentication Code
DAC	Digital to Analog Converter	MCU	Microcontroller Unit
DC	Direct Current	MFR	MAC Footer
DMA	Direct Memory Access	MHR	MAC Header
DNL	Differential Nonlinearity	MIC	Message Integrity Code
DSM	Delta Sigma Modulator	MISO	Master In Slave Out
DSSS	Direct Sequence Spread Spectrum	MOSI	Master Out Slave In
ECB	Electronic Code Book (encryption)	MPDU	MAC Protocol Data Unit
EM	Evaluation Module	MSB	Most Significant Byte
ENOB	Effective Number of bits	MSDU	MAC Service Data Unit
ESD	Electro Static Discharge	MUX	Multiplexer
ESR	Equivalent Series Resistance	NA	Not Available
ETSI	European Telecommunications Standards Institute	NC	Not Connected
EVM	Error Vector Magnitude	OFB	Output Feedback (encryption)
FCC	Federal Communications Commission	O-QPSK	Offset - Quadrature Phase Shift Keying
FCF	Frame Control Field	PA	Power Amplifier
FCS	Frame Check Sequence	PCB	Printed Circuit Board
FFCTRL	FIFO and Frame Control	PER	Packet Error Rate
FIFO	First In First Out	PHR	PHY Header
HF	High Frequency	PHY	Physical Layer
HSSD	High Speed Serial Data	PLL	Phase Locked Loop

PM{0-3}	Power Mode 0-3	SPI	Serial Peripheral Interface
PMC	Power Management Controller	SRAM	Static Random Access Memory
POR	Power On Reset	ST	Sleep Timer
PSDU	PHY Service Data Unit	T/R	Tape and reel
PWM	Pulse Width Modulator	T/R	Transmit / Receive
QLP	Quad Leadless Package	TBD	To Be Decided / To Be Defined
RAM	Random Access Memory	THD	Total Harmonic Distortion
RBW	Resolution Bandwidth	TI	Texas Instruments
RC	Resistor-Capacitor	TX	Transmit
RCOSC	RC Oscillator	UART	Universal Asynchronous Receiver/Transmitter
RF	Radio Frequency	USART	Universal Synchronous/Asynchronous Receiver/Transmitter
RoHS	Restriction on Hazardous Substances	VCO	Voltage Controlled Oscillator
RSSI	Receive Signal Strength Indicator	VGA	Variable Gain Amplifier
RTC	Real-Time Clock	WDT	Watchdog Timer
RX	Receive	XOSC	Crystal Oscillator
SCK	Serial Clock		
SFD	Start of Frame Delimiter		
SFR	Special Function Register		
SHR	Synchronization Header		
SINAD	Signal-to-noise and distortion ratio		

## 2 References

- [1] IEEE std. 802.15.4 - 2003: Wireless Medium Access Control (MAC) and Physical Layer (PHY) specifications for Low Rate Wireless Personal Area Networks (LR-WPANs)  
<http://standards.ieee.org/getieee802/download/802.15.4-2003.pdf>
- [2] NIST FIPS Pub 197: Advanced Encryption Standard (AES), Federal Information Processing Standards Publication 197, US Department of Commerce/N.I.S.T., November 26, 2001. Available from the NIST website.  
<http://csrc.nist.gov/publications/fips/fips197/fips-197.pdf>

### 3 Register conventions

Each SFR register is described in a separate table. The table heading is given in the following format:

REGISTER NAME (SFR Address) - Register Description.

Each RF register is described in a separate table. The table heading is given in the following format:

REGISTER NAME (XDATA Address)

In the register descriptions, each register bit is shown with a symbol indicating the access mode of the register bit. The register values are always given in binary notation unless prefixed by '0x' which indicates hexadecimal notation.

**Table 1: Register bit conventions**

Symbol	Access Mode
R/W	Read/write
R	Read only
R0	Read as 0
R1	Read as 1
W	Write only
W0	Write as 0
W1	Write as 1
H0	Hardware clear
H1	Hardware set

## 4 Features Emphasized

### 4.1 High-Performance and Low-Power 8051-Compatible Microcontroller

- Optimized 8051 core, which typically gives 8x the performance of a standard 8051
- Dual data pointers
- In-circuit interactive debugging is supported for the IAR Embedded Workbench through a simple two-wire serial interface

### 4.2 Up to 128 KB Non-volatile Program Memory and 2 x 4 KB Data Memory

- 32/64/128 KB of non-volatile flash memory in-system programmable through a simple two-wire interface or by the 8051 core
- Worst-case flash memory endurance: 1000 write/erase cycles
- Programmable read and write lock of portions of Flash memory for software security
- 4096 bytes of internal SRAM with data retention in all power modes
- Additional 4096 bytes of internal SRAM with data retention in power modes 0 and 1

### 4.3 Hardware AES Encryption/Decryption

- AES supported in hardware coprocessor

### 4.4 Peripheral Features

- Powerful DMA Controller
- Power On Reset/Brown-Out Detection
- Eight channel ADC with configurable resolution
- Programmable watchdog timer
- Real time clock with 32.768 kHz crystal oscillator
- Four timers: one general 16-bit timer, two general 8-bit timers, one MAC timer
- Two programmable USARTs for master/slave SPI or UART operation
- 21 configurable general-purpose digital I/O-pins
- True random number generator

### 4.5 Low Power

- Four flexible power modes for reduced power consumption
- System can wake up on external interrupt or real-time counter event
- Low-power fully static CMOS design
- System clock source can be 16 MHz RC oscillator or 32 MHz crystal oscillator. The 32 MHz oscillator is used when radio is active
- Optional clock source for ultra-low power operation can be either low-power RC oscillator or an optional 32.768 kHz crystal oscillator

### 4.6 IEEE 802.15.4 MAC hardware support

- Automatic preamble generator
- Synchronization word insertion/detection
- CRC-16 computation and checking over the MAC payload
- Clear Channel Assessment
- Energy detection / digital RSSI
- Link Quality Indication
- CSMA/CA Coprocessor

### 4.7 Integrated 2.4GHz DSSS Digital Radio

- 2.4 GHz IEEE 802.15.4 compliant RF transceiver (based on industry leading *CC2420* radio core).
- Excellent receiver sensitivity and robustness to interferers
- 250 kbps data rate, 2 MChip/s chip rate
- Reference designs comply with worldwide radio frequency regulations covered by ETSI EN 300 328 and EN 300 440 class 2 (Europe), FCC CFR47 Part 15 (US) and ARIB STD-T66 (Japan). Transmit on 2480MHz under FCC is supported by duty-cycling, or by reducing output power.

## 5 Absolute Maximum Ratings

Under no circumstances must the absolute maximum ratings given in Table 2 be violated. Stress exceeding one or more of the limiting values may cause permanent damage to the device.

**Table 2: Absolute Maximum Ratings**

Parameter	Min	Max	Units	Condition
Supply voltage	-0.3	3.9	V	All supply pins must have the same voltage
Voltage on any digital pin	-0.3	VDD+0.3, max 3.9	V	
Voltage on the 1.8V pins (pin no. 22, 25-40 and 42)	-0.3	2.0	V	
Input RF level		10	dBm	
Storage temperature range	-50	150	°C	Device not programmed
Reflow soldering temperature		260	°C	According to IPC/JEDEC J-STD-020C
ESD		<500	V	On RF pads (RF_P, RF_N, AVDD_RF1, and AVDD_RF2), according to Human Body Model, JEDEC STD 22, method A114
		700	V	All other pads, according to Human Body Model, JEDEC STD 22, method A114
		200	V	According to Charged Device Model, JEDEC STD 22, method C101



**Caution!** ESD sensitive device. Precaution should be used when handling the device in order to prevent permanent damage.

## 6 Operating Conditions

The operating conditions for **CC2430** are listed in Table 3.

**Table 3: Operating Conditions**

Parameter	Min	Max	Unit	Condition
Operating ambient temperature range, T <sub>A</sub>	-40	85	°C	
Operating supply voltage	2.0	3.6	V	The supply pins to the radio part must be driven by the 1.8 V on-chip regulator

## 7 Electrical Specifications

Measured on Texas Instruments **CC2430** EM reference design with  $T_A=25^\circ\text{C}$  and  $V_{DD}=3.0\text{V}$  unless stated otherwise.

**Table 4: Electrical Specifications**

Parameter	Min	Typ	Max	Unit	Condition
<b>Current Consumption</b>					
MCU Active Mode, 16 MHz, low MCU activity		4.3		mA	Digital regulator on. 16 MHz RCOSC running. No radio, crystals, or peripherals active. Low MCU activity: no flash access (i.e. only cache hit), no RAM access.
MCU Active Mode, 16 MHz, medium MCU activity		5.1		mA	Digital regulator on. 16 MHz RCOSC running. No radio, crystals, or peripherals active. Medium MCU activity: normal flash access <sup>1</sup> , minor RAM access.
MCU Active Mode, 16 MHz, high MCU activity		5.7		mA	Digital regulator on. 16 MHz RCOSC running. No radio, crystals, or peripherals active. High MCU activity: normal flash access <sup>1</sup> , extensive RAM access and heavy CPU load.
MCU Active Mode, 32 MHz, low MCU activity		9.5		mA	32 MHz XOSC running. No radio or peripherals active. Low MCU activity : no flash access (i.e. only cache hit), no RAM access
MCU Active Mode, 32 MHz, medium MCU activity		10.5		mA	32 MHz XOSC running. No radio or peripherals active. Medium MCU activity: normal flash access <sup>1</sup> , minor RAM access.
MCU Active Mode, 32 MHz, high MCU activity		12.3		mA	32 MHz XOSC running. No radio or peripherals active. High MCU activity: normal flash access <sup>1</sup> , extensive RAM access and heavy CPU load.
MCU Active and RX Mode		26.7		mA	MCU running at full speed (32MHz), 32MHz XOSC running, radio in RX mode, -50 dBm input power. No peripherals active. Low MCU activity.
MCU Active and TX Mode, 0dBm		26.9		mA	MCU running at full speed (32MHz), 32MHz XOSC running, radio in TX mode, 0dBm output power. No peripherals active. Low MCU activity.
Power mode 1		190		$\mu\text{A}$	Digital regulator on, 16 MHz RCOSC and 32 MHz crystal oscillator off. 32.768 kHz XOSC, POR and ST active. RAM retention.
Power mode 2		0.5		$\mu\text{A}$	Digital regulator off, 16 MHz RCOSC and 32 MHz crystal oscillator off. 32.768 kHz XOSC, POR and ST active. RAM retention.
Power mode 3		0.3		$\mu\text{A}$	No clocks. RAM retention. POR active.
<b>Peripheral Current Consumption</b>					
Adds to the figures above if the peripheral unit is activated					
Timer 1		150		$\mu\text{A}$	Timer running, 32MHz XOSC used.
Timer 2		230		$\mu\text{A}$	Timer running, 32MHz XOSC used.
Timer 3		50		$\mu\text{A}$	Timer running, 32MHz XOSC used.
Timer 4		50		$\mu\text{A}$	Timer running, 32MHz XOSC used.
Sleep Timer		0.2		$\mu\text{A}$	Including 32.753 kHz RCOSC.
ADC		1.2		mA	When converting.
Flash write		3		mA	Estimated value
Flash erase		3		mA	Estimated value

<sup>1</sup> Normal Flash access means that the code used exceeds the cache storage (see last paragraph in section 11.2.3 Flash memory) so cache misses will happen frequently.

## 7.1 General Characteristics

Measured on Texas Instruments **CC2430** EM reference design with  $T_A=25^\circ\text{C}$  and  $V_{DD}=3.0\text{V}$  unless stated otherwise.

**Table 5: General Characteristics**

Parameter	Min	Typ	Max	Unit	Condition/Note
<b>Wake-Up and Timing</b>					
Power mode 1 → power mode 0		4.1		μs	Digital regulator on, 16 MHz RCOSC and 32 MHz crystal oscillator off. Start-up of 16 MHz RCOSC.
Power mode 2 or 3 → power mode 0		120		μs	Digital regulator off, 16 MHz RCOSC and 32 MHz crystal oscillator off. Start-up of regulator and 16 MHz RCOSC.
Active → TX or RX 32MHz XOSC initially OFF. Voltage regulator initially OFF		525		μs	Time from enabling radio part in power mode 0, until TX or RX starts. Includes start-up of voltage regulator and crystal oscillator in parallel. Crystal ESR=16Ω.
Active → TX or RX Voltage regulator initially OFF		320		μs	Time from enabling radio part in power mode 0, until TX or RX starts. Includes start-up of voltage regulator.
Active → RX or TX			192	μs	Radio part already enabled. Time until RX or TX starts.
RX/TX turnaround			192	μs	
<b>Radio part</b>					
RF Frequency Range	2400		2483.5	MHz	Programmable in 1 MHz steps, 5 MHz between channels for compliance with [1]
Radio bit rate		250		kbps	As defined by [1]
Radio chip rate		2.0		MChip/s	As defined by [1]

## 7.2 RF Receive Section

Measured on Texas Instruments **CC2430** EM reference design with  $T_A=25^\circ\text{C}$  and  $V_{DD}=3.0\text{V}$  unless stated otherwise.

**Table 6: RF Receive Parameters**

Parameter	Min	Typ	Max	Unit	Condition/Note
Receiver sensitivity		-92		dBm	PER = 1%, as specified by [1] Measured in 50 $\Omega$ single endedly through a balun. [1] requires -85 dBm
Saturation (maximum input level)		10		dBm	PER = 1%, as specified by [1] Measured in 50 $\Omega$ single endedly through a balun. [1] requires -20 dBm
Adjacent channel rejection + 5 MHz channel spacing		41		dB	Wanted signal -88dBm, adjacent modulated channel at +5 MHz, PER = 1 %, as specified by [1]. [1] requires 0 dB
Adjacent channel rejection - 5 MHz channel spacing		30		dB	Wanted signal -88dBm, adjacent modulated channel at -5 MHz, PER = 1 %, as specified by [1]. [1] requires 0 dB
Alternate channel rejection + 10 MHz channel spacing		55		dB	Wanted signal -88dBm, adjacent modulated channel at +10 MHz, PER = 1 %, as specified by [1] [1] requires 30 dB
Alternate channel rejection - 10 MHz channel spacing		53		dB	Wanted signal -88dBm, adjacent modulated channel at -10 MHz, PER = 1 %, as specified by [1] [1] requires 30 dB
Channel rejection $\geq + 15$ MHz $\leq - 15$ MHz		55 53		dB dB	Wanted signal @ -82 dBm. Undesired signal is an 802.15.4 modulated channel, stepped through all channels from 2405 to 2480 MHz. Signal level for PER = 1%. Values are estimated.
Co-channel rejection		-6		dB	Wanted signal @ -82 dBm. Undesired signal is 802.15.4 modulated at the same frequency as the desired signal. Signal level for PER = 1%.
Blocking / Desensitization + 5 MHz from band edge + 10 MHz from band edge + 20 MHz from band edge + 50 MHz from band edge - 5 MHz from band edge - 10 MHz from band edge - 20 MHz from band edge - 50 MHz from band edge		-42 -45 -26 -22 -31 -36 -24 -25		dBm dBm dBm dBm dBm dBm dBm dBm	Wanted signal 3 dB above the sensitivity level, CW jammer, PER = 1%. Measured according to EN 300 440 class 2.
Spurious emission 30 – 1000 MHz 1 – 12.75 GHz			-64 -75	dBm dBm	Conducted measurement in a 50 $\Omega$ single ended load. Complies with EN 300 328, EN 300 440 class 2, FCC CFR47, Part 15 and ARIB STD-T-66.
Frequency error tolerance		$\pm 140$		ppm	Difference between centre frequency of the received RF signal and local oscillator frequency. [1] requires minimum 80 ppm
Symbol rate error tolerance		$\pm 900$		ppm	Difference between incoming symbol rate and the internally generated symbol rate [1] requires minimum 80 ppm

## 7.3 RF Transmit Section

Measured on Texas Instruments **CC2430** EM reference design with  $T_A=25^\circ\text{C}$ ,  $V_{DD}=3.0\text{V}$ , and nominal output power unless stated otherwise.

Table 7: RF Transmit Parameters

Parameter	Min	Typ	Max	Unit	Condition/Note
Nominal output power		0		dBm	Delivered to a single ended 50 Ω load through a balun and output power control set to 0x5F (TXCTRL). [1] requires minimum -3 dBm
Programmable output power range		26		dB	The output power is programmable in 16 steps from typically -25.2 to 0.6 dBm (see Table 45).
Harmonics 2 <sup>nd</sup> harmonic 3 <sup>rd</sup> harmonic 4 <sup>th</sup> harmonic 5 <sup>th</sup> harmonic		-50.7 -55.8 -54.2 -53.4		dBm dBm dBm dBm	Measurement conducted with 100 kHz resolution bandwidth on spectrum analyzer and output power control set to 0x5F (TXCTRL). Output Delivered to a single ended 50 Ω load through a balun.
Spurious emission 30 - 1000 MHz 1- 12.75 GHz 1.8 - 1.9 GHz 5.15 - 5.3 GHz		-47 -43 -58 -56		dBm dBm dBm dBm	Maximum output power. Texas Instruments <b>CC2430</b> EM reference design complies with EN 300 328, EN 300 440, FCC CFR47 Part 15 and ARIB STD-T-66. Transmit on 2480MHz under FCC is supported by duty-cycling, or by reducing output power  The peak conducted spurious emission is -47 dBm @ 192 MHz which is in an EN 300 440 restricted band limited to -54 dBm. All radiated spurious emissions are within the limits of ETSI/FCC/ARIB. Conducted spurious emission (CSE) can be reduced with a simple band pass filter connected between matching network and RF connector (1.8 pF in parallel with 1.6 nH reduces the CSE by 20 dB), this filter must be connected to good RF ground.
Error Vector Magnitude (EVM)		11		%	Measured as defined by [1] [1] requires max. 35 %
Optimum load impedance		60 + j164		Ω	Differential impedance as seen from the RF-port (RF_P and RF_N) towards the antenna <sup>2</sup> .

#### 7.4 32 MHz Crystal Oscillator

Measured on Texas Instruments **CC2430** EM reference design with T<sub>A</sub>=25°C and VDD=3.0V unless stated otherwise.

Table 8: 32 MHz Crystal Oscillator Parameters

Parameter	Min	Typ	Max	Unit	Condition/Note
Crystal frequency		32		MHz	
Crystal frequency accuracy requirement	- 40		40	ppm	Including aging and temperature dependency, as specified by [1]
ESR	6	16	60	Ω	Simulated over operating conditions
C <sub>0</sub>	1	1.9	7	pF	Simulated over operating conditions
C <sub>L</sub>	10	13	16	pF	Simulated over operating conditions
Start-up time		212		μs	

#### 7.5 32.768 kHz Crystal Oscillator

Measured on Texas Instruments **CC2430** EM reference design with T<sub>A</sub>=25°C and VDD=3.0V unless stated otherwise.

<sup>2</sup> This is for 2440MHz

Table 9: 32.768 kHz Crystal Oscillator Parameters

Parameter	Min	Typ	Max	Unit	Condition/Note
Crystal frequency		32.768		kHz	
Crystal frequency accuracy requirement	-40		40	ppm	Including aging and temperature dependency, as specified by [1]
ESR		40	130	k $\Omega$	Simulated over operating conditions
C <sub>0</sub>		0.9	2.0	pF	Simulated over operating conditions
C <sub>L</sub>		12	16	pF	Simulated over operating conditions
Start-up time		400		ms	Value is simulated.

## 7.6 32 kHz RC Oscillator

Measured on Texas Instruments *CC2430* EM reference design with T<sub>A</sub>=25°C and VDD=3.0V unless stated otherwise.

Table 10: 32 kHz RC Oscillator parameters

Parameter	Min	Typ	Max	Unit	Condition/Note
Calibrated frequency		32.753		kHz	The calibrated 32 kHz RC Oscillator frequency is the 32 MHz XTAL frequency divided by 977
Frequency accuracy after calibration		±0.2		%	Value is estimated.
Temperature coefficient		+0.4		% / °C	Frequency drift when temperature changes after calibration. Value is estimated.
Supply voltage coefficient		+3		% / V	Frequency drift when supply voltage changes after calibration. Value is estimated.
Initial calibration time		1.7		ms	When the 32 kHz RC Oscillator is enabled, calibration is continuously done in the background as long as the 32 MHz crystal oscillator is running and SLEEP.OSC32K_CALDIS bit is cleared.

## 7.7 16 MHz RC Oscillator

Measured on Texas Instruments *CC2430* EM reference design with T<sub>A</sub>=25°C and VDD=3.0V unless stated otherwise.

Table 11: 16 MHz RC Oscillator parameters

Parameter	Min	Typ	Max	Unit	Condition/Note
Frequency		16		MHz	The calibrated 16 MHz RC Oscillator frequency is the 32 MHz XTAL frequency divided by 2
Uncalibrated frequency accuracy		±18		%	
Calibrated frequency accuracy		±0.6	±1	%	
Start-up time			10	μs	
Temperature coefficient			-325	ppm / °C	Frequency drift when temperature changes after calibration
Supply voltage coefficient			28	ppm / mV	Frequency drift when supply voltage changes after calibration
Initial calibration time		50		μs	When the 16 MHz RC Oscillator is enabled it will be calibrated continuously when the 32MHz crystal oscillator is running.

### 7.8 Frequency Synthesizer Characteristics

Measured on Texas Instruments **CC2430** EM reference design with  $T_A=25^\circ\text{C}$  and  $V_{DD}=3.0\text{V}$  unless stated otherwise.

**Table 12: Frequency Synthesizer Parameters**

Parameter	Min	Typ	Max	Unit	Condition/Note
Phase noise		-116 -117 -118		dBc/Hz dBc/Hz dBc/Hz	Unmodulated carrier At $\pm 1.5$ MHz offset from carrier At $\pm 3$ MHz offset from carrier At $\pm 5$ MHz offset from carrier
PLL lock time			192	$\mu\text{s}$	The startup time until RX/TX turnaround. The crystal oscillator is running.

### 7.9 Analog Temperature Sensor

Measured on Texas Instruments **CC2430** EM reference design with  $T_A=25^\circ\text{C}$  and  $V_{DD}=3.0\text{V}$  unless stated otherwise.

**Table 13: Analog Temperature Sensor Parameters**

Parameter	Min	Typ	Max	Unit	Condition/Note
Output voltage at $-40^\circ\text{C}$		0.648		V	Value is estimated
Output voltage at $0^\circ\text{C}$		0.743		V	Value is estimated
Output voltage at $+40^\circ\text{C}$		0.840		V	Value is estimated
Output voltage at $+80^\circ\text{C}$		0.939		V	Value is estimated
Temperature coefficient		2.45		mV/ $^\circ\text{C}$	Fitted from $-20^\circ\text{C}$ to $+80^\circ\text{C}$ on estimated values.
Absolute error in calculated temperature		-8		$^\circ\text{C}$	From $-20^\circ\text{C}$ to $+80^\circ\text{C}$ when assuming best fit for absolute accuracy on estimated values: 0.743V at $0^\circ\text{C}$ and 2.45mV / $^\circ\text{C}$ .
Error in calculated temperature, calibrated	-2	0	2	$^\circ\text{C}$	From $-20^\circ\text{C}$ to $+80^\circ\text{C}$ when using 2.45mV / $^\circ\text{C}$ , after 1-point calibration at room temperature. Values are estimated. Indicated min/max with 1-point calibration is based on simulated values for typical process parameters
Current consumption increase when enabled		280		$\mu\text{A}$	

### 7.10 ADC

Measured with  $T_A=25^\circ\text{C}$  and  $V_{DD}=3.0\text{V}$ . Note that other data may result using Texas Instruments **CC2430** EM reference design.

**Table 14: ADC Characteristics**

Parameter	Min	Typ	Max	Unit	Condition/Note
Input voltage	0		VDD	V	VDD is voltage on AVDD_SOC pin
External reference voltage	0		VDD	V	VDD is voltage on AVDD_SOC pin
External reference voltage differential	0		VDD	V	VDD is voltage on AVDD_SOC pin
Input resistance, signal		197		k $\Omega$	Simulated using 4 MHz clock speed (see section 13.10.2.7)
Full-Scale Signal <sup>3</sup>		2.97		V	Peak-to-peak, defines 0dBFS

<sup>3</sup> Measured with 300 Hz Sine input and VDD as reference.

Parameter	Min	Typ	Max	Unit	Condition/Note
ENOB <sup>3</sup> Single ended input		5.7 7.5 9.3 10.8		bits	7-bits setting. 9-bits setting. 10-bits setting. 12-bits setting.
ENOB <sup>3</sup> Differential input		6.5 8.3 10.0 11.5		bits	7-bits setting. 9-bits setting. 10-bits setting. 12-bits setting.
Useful Power Bandwidth		0-20		kHz	7-bits setting, both single and differential
THD <sup>3</sup> -Single ended input -Differential input		-75.2 -86.6		dB dB	12-bits setting, -6dBFS 12-bits setting, -6dBFS
Signal To Non-Harmonic Ratio <sup>3</sup> -Single ended input -Differential input		70.2 79.3		dB dB	12-bits setting 12-bits setting
Spurious Free Dynamic Range <sup>3</sup> -Single ended input -Differential input		78.8 88.9		dB dB	12-bits setting, -6dBFS 12-bits setting, -6dBFS
CMRR, differential input		<-84		dB	12- bit setting, 1 kHz Sine (0dBFS), limited by ADC resolution
Crosstalk, single ended input		<-84		dB	12- bit setting, 1 kHz Sine (0dBFS), limited by ADC resolution
Offset		-3		mV	Mid. scale
Gain error		0.68		%	
DNL <sup>3</sup>		0.05 0.9		LSB LSB	12-bits setting, mean 12-bits setting, max
INL <sup>3</sup>		4.6 13.3		LSB LSB	12-bits setting, mean 12-bits setting, max
SINAD <sup>3</sup> Single ended input (-THD+N)		35.4 46.8 57.5 66.6		dB dB dB dB	7-bits setting. 9-bits setting. 10-bits setting. 12-bits setting.
SINAD <sup>3</sup> Differential input (-THD+N)		40.7 51.6 61.8 70.8		dB dB dB dB	7-bits setting. 9-bits setting. 10-bits setting. 12-bits setting.
Conversion time		20 36 68 132		μs μs μs μs	7-bits setting. 9-bits setting. 10-bits setting. 12-bits setting.
Power Consumption		1.2		mA	

7.11 Control AC Characteristics

T<sub>A</sub>= -40°C to 85°C, VDD=2.0V to 3.6V if nothing else stated.

Table 15: Control Inputs AC Characteristics

Parameter	Min	Typ	Max	Unit	Condition/Note
System clock, f <sub>SYSCLK</sub> t <sub>SYSCLK</sub> = 1/ f <sub>SYSCLK</sub>	16		32	MHz	System clock is 32 MHz when crystal oscillator is used. System clock is 16 MHz when calibrated 16 MHz RC oscillator is used.
RESET_N low width	250			ns	See item 1, Figure 1. This is the shortest pulse that is guaranteed to be recognized as a complete reset pin request. Note that shorter pulses may be recognized but will not lead to complete reset of all modules within the chip.
Interrupt pulse width	t <sub>SYSCLK</sub>			ns	See item 2, Figure 1. This is the shortest pulse that is guaranteed to be recognized as an interrupt request. In PM2/3 the internal synchronizers are bypassed so this requirement does not apply in PM2/3.

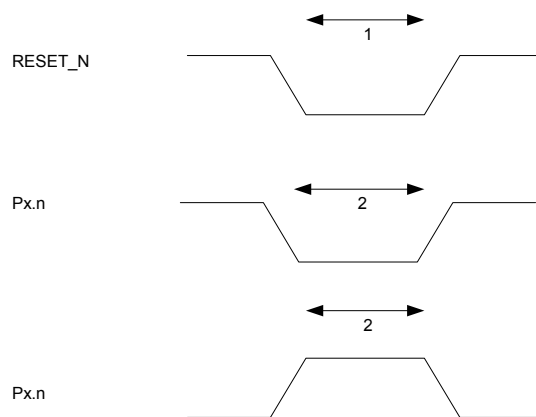

Figure 1: Control Inputs AC Characteristics

7.12 SPI AC Characteristics

T<sub>A</sub>= -40°C to 85°C, VDD=2.0V to 3.6V if nothing else stated.

Table 16: SPI AC Characteristics

Parameter	Min	Typ	Max	Unit	Condition/Note
SCK period		See section 13.14.4		ns	Master. See item 1 Figure 2
SCK duty cycle		50%			Master.
SSN low to SCK	2*t <sub>SYSCLK</sub>				See item 5 Figure 2
SCK to SSN high	30			ns	See item 6 Figure 2
MISO setup	10			ns	Master. See item 2 Figure 2
MISO hold	10			ns	Master. See item 3 Figure 2
SCK to MOSI			25	ns	Master. See item 4 Figure 2, load = 10 pF
SCK period	100			ns	Slave. See item 1 Figure 2
SCK duty cycle		50%			Slave.
MOSI setup	10			ns	Slave. See item 2 Figure 2
MOSI hold	10			ns	Slave. See item 3 Figure 2
SCK to MISO			25	ns	Slave. See item 4 Figure 2, load = 10 pF

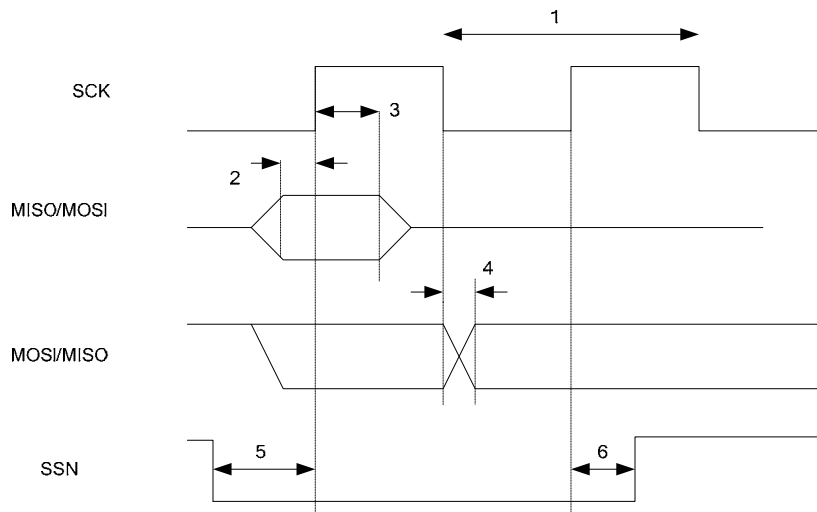

Figure 2: SPI AC Characteristics

7.13 Debug Interface AC Characteristics

T<sub>A</sub>= -40°C to 85°C, VDD=2.0V to 3.6V if nothing else stated.

Table 17: Debug Interface AC Characteristics

Parameter	Min	Typ	Max	Unit	Condition/Note
Debug clock period	128			ns	See item 1 Figure 3
Debug data setup	5			ns	See item 2 Figure 3
Debug data hold	5			ns	See item 3 Figure 3
Clock to data delay			10	ns	See item 4 Figure 3, load = 10 pF
RESET_N inactive after P2_2 rising	10			ns	See item 5 Figure 3

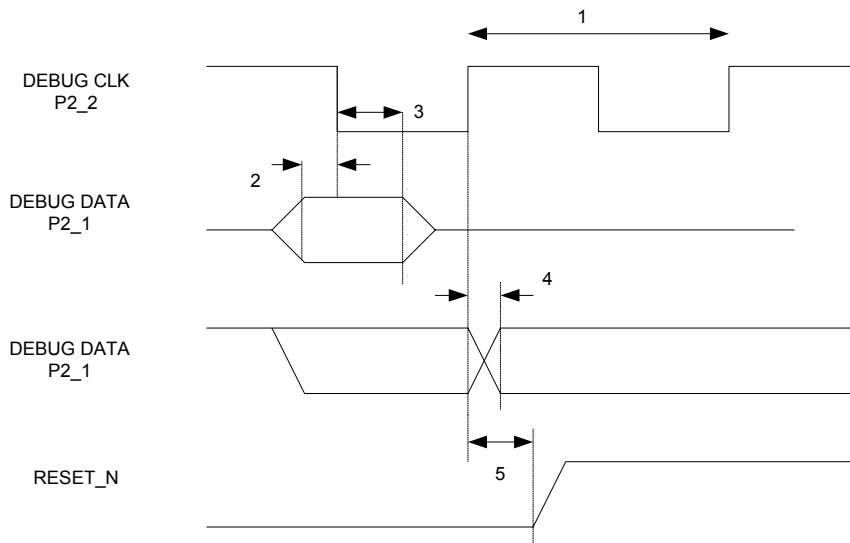

Figure 3: Debug Interface AC Characteristics

### 7.14 Port Outputs AC Characteristics

T<sub>A</sub>= 25°C, VDD=3.0V if nothing else stated.

Table 18: Port Outputs AC Characteristics

Parameter	Min	Typ	Max	Unit	Condition/Note
P0_[0:7], P1_[2:7], P2_[0:4] Port output rise time (SC=0/SC=1)		3.15/ 1.34		ns	Load = 10 pF Timing is with respect to 10% VDD and 90% VDD levels. Values are estimated
fall time (SC=0/SC=1)		3.2/ 1.44			Load = 10 pF Timing is with respect to 90% VDD and 10% VDD. Values are estimated

### 7.15 Timer Inputs AC Characteristics

T<sub>A</sub>= -40°C to 85°C, VDD=2.0V to 3.6V if nothing else stated.

Table 19: Timer Inputs AC Characteristics

Parameter	Min	Typ	Max	Unit	Condition/Note
Input capture pulse width	t <sub>SYCLK</sub>			ns	Synchronizers determine the shortest input pulse that can be recognized. The synchronizers operate at the current system clock rate (16 or 32 MHz)

### 7.16 DC Characteristics

The DC Characteristics of **CC2430** are listed in Table 20 below.

T<sub>A</sub>=25°C, VDD=3.0V if nothing else stated.

Table 20: DC Characteristics

Digital Inputs/Outputs	Min	Typ	Max	Unit	Condition
Logic "0" input voltage			0.5	V	
Logic "1" input voltage	VDD-0.5			V	
Logic "0" input current	NA		-1	μA	Input equals 0V
Logic "1" input current	NA		1	μA	Input equals VDD
I/O pin pull-up and pull-down resistor		20		kΩ	

## 8 Pin and I/O Port Configuration

The *CC2430* pinout is shown in Figure 4 and Table 21. See section 13.4 for details on the configuration of digital I/O ports.

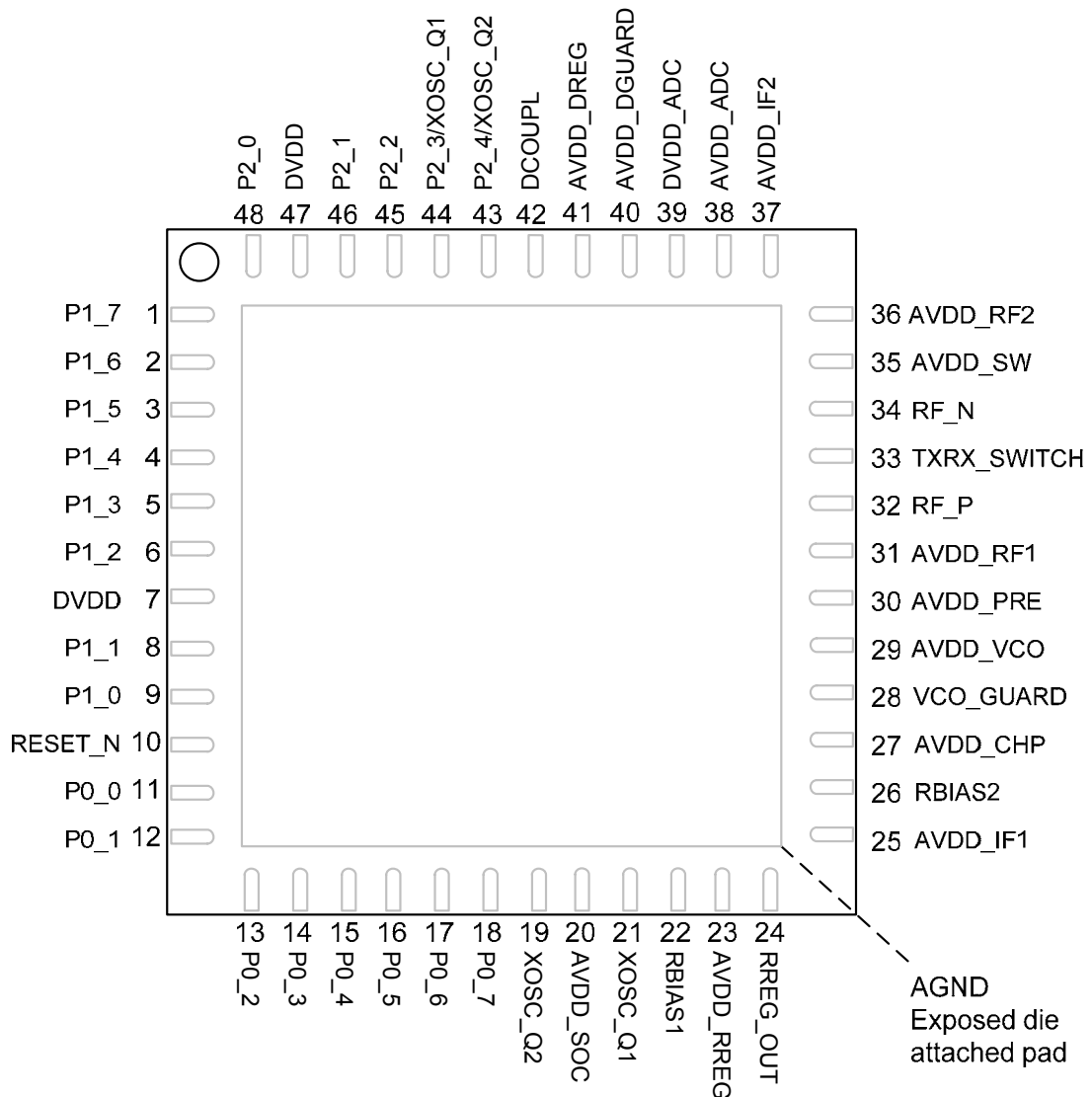

Figure 4: Pinout top view

Note: The exposed die attach pad **must** be connected to a solid ground plane as this is the ground connection for the chip.

**Table 21: Pinout overview**

Pin	Pin name	Pin type	Description
-	GND	Ground	The exposed die attach pad must be connected to a solid ground plane
1	P1_7	Digital I/O	Port 1.7
2	P1_6	Digital I/O	Port 1.6
3	P1_5	Digital I/O	Port 1.5
4	P1_4	Digital I/O	Port 1.4
5	P1_3	Digital I/O	Port 1.3
6	P1_2	Digital I/O	Port 1.2
7	DVDD	Power (Digital)	2.0V-3.6V digital power supply for digital I/O
8	P1_1	Digital I/O	Port 1.1 – 20 mA drive capability
9	P1_0	Digital I/O	Port 1.0 – 20 mA drive capability
10	RESET_N	Digital input	Reset, active low
11	P0_0	Digital I/O	Port 0.0
12	P0_1	Digital I/O	Port 0.1
13	P0_2	Digital I/O	Port 0.2
14	P0_3	Digital I/O	Port 0.3
15	P0_4	Digital I/O	Port 0.4
16	P0_5	Digital I/O	Port 0.5
17	P0_6	Digital I/O	Port 0.6
18	P0_7	Digital I/O	Port 0.7
19	XOSC_Q2	Analog I/O	32 MHz crystal oscillator pin 2
20	AVDD_SOC	Power (Analog)	2.0V-3.6V analog power supply connection
21	XOSC_Q1	Analog I/O	32 MHz crystal oscillator pin 1, or external clock input
22	RBIAS1	Analog I/O	External precision bias resistor for reference current
23	AVDD_RREG	Power (Analog)	2.0V-3.6V analog power supply connection
24	RREG_OUT	Power output	1.8V Voltage regulator power supply output. Only intended for supplying the analog 1.8V part (power supply for pins 25, 27-31, 35-40).
25	AVDD_IF1	Power (Analog)	1.8V Power supply for the receiver band pass filter, analog test module, global bias and first part of the VGA
26	RBIAS2	Analog output	External precision resistor, 43 kΩ, ±1 %
27	AVDD_CHP	Power (Analog)	1.8V Power supply for phase detector, charge pump and first part of loop filter
28	VCO_GUARD	Power (Analog)	Connection of guard ring for VCO (to AVDD) shielding
29	AVDD_VCO	Power (Analog)	1.8V Power supply for VCO and last part of PLL loop filter
30	AVDD_PRE	Power (Analog)	1.8V Power supply for Prescaler, Div-2 and LO buffers
31	AVDD_RF1	Power (Analog)	1.8V Power supply for LNA, front-end bias and PA
32	RF_P	RF I/O	Positive RF input signal to LNA during RX. Positive RF output signal from PA during TX
33	TXRX_SWITCH	Power (Analog)	Regulated supply voltage for PA
34	RF_N	RF I/O	Negative RF input signal to LNA during RX Negative RF output signal from PA during TX
35	AVDD_SW	Power (Analog)	1.8V Power supply for LNA / PA switch
36	AVDD_RF2	Power (Analog)	1.8V Power supply for receive and transmit mixers
37	AVDD_IF2	Power (Analog)	1.8V Power supply for transmit low pass filter and last stages of VGA
38	AVDD_ADC	Power (Analog)	1.8V Power supply for analog parts of ADCs and DACs
39	DVDD_ADC	Power (Digital)	1.8V Power supply for digital parts of ADCs
40	AVDD_DGUARD	Power (Digital)	Power supply connection for digital noise isolation
41	AVDD_DREG	Power (Digital)	2.0V-3.6V digital power supply for digital core voltage regulator
42	DCOUPPL	Power (Digital)	1.8V digital power supply decoupling. Do not use for supplying external circuits.
43	P2_4/XOSC_Q2	Digital I/O	Port 2.4/32.768 kHz XOSC
44	P2_3/XOSC_Q1	Digital I/O	Port 2.3/32.768 kHz XOSC
45	P2_2	Digital I/O	Port 2.2
46	P2_1	Digital I/O	Port 2.1
47	DVDD	Power (Digital)	2.0V-3.6V digital power supply for digital I/O
48	P2_0	Digital I/O	Port 2.0

9 Circuit Description

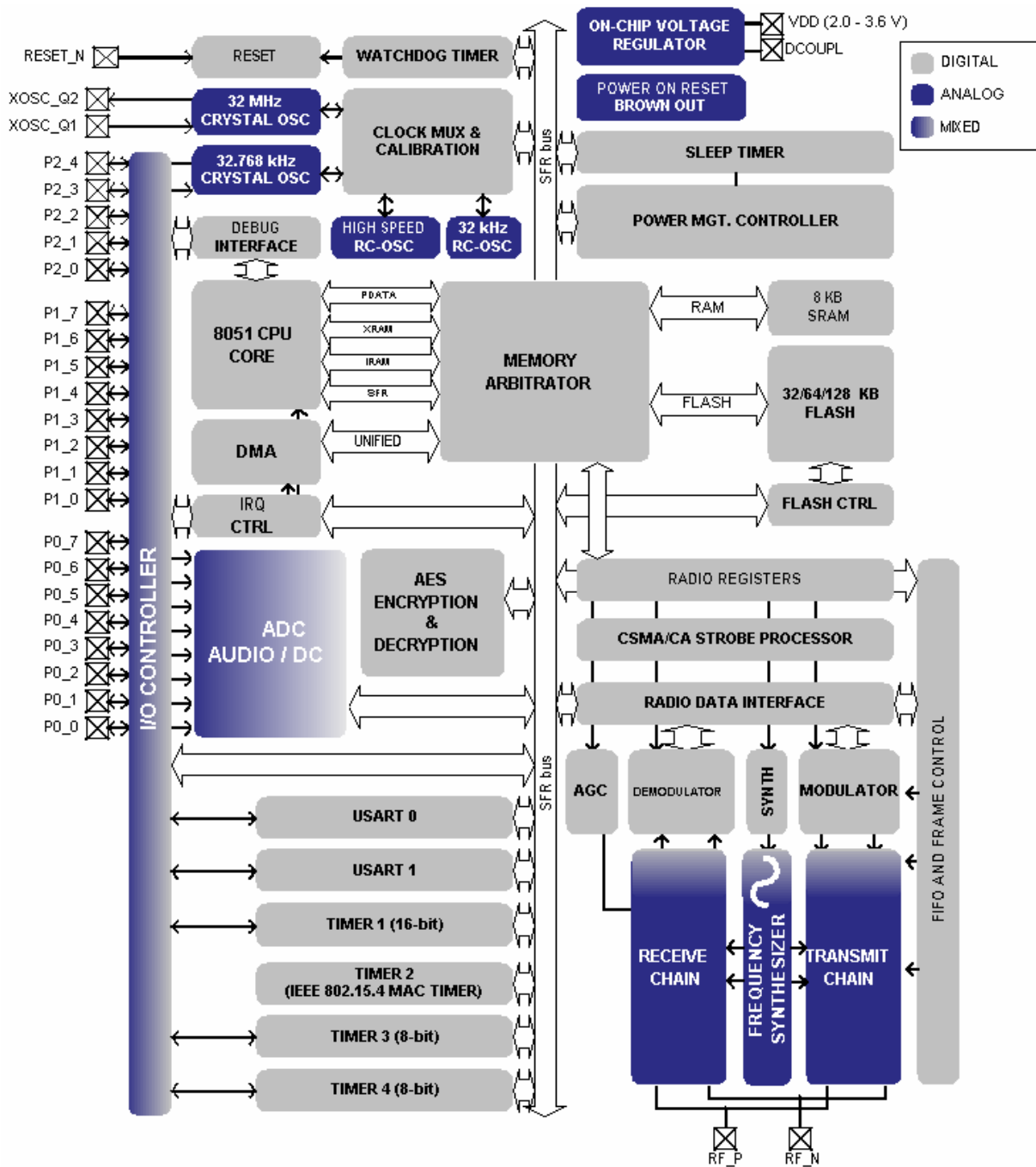

Figure 5: CC2430 Block Diagram

A block diagram of *CC2430* is shown in Figure 5. The modules can be roughly divided into one of three categories: CPU-related modules, modules related to power, test and clock

distribution, and radio-related modules. In the following subsections, a short description of each module that appears in Figure 5 is given.

## 9.1 CPU and Peripherals

The **8051 CPU core** is a single-cycle 8051-compatible core. It has three different memory access buses (SFR, DATA and CODE/XDATA), a debug interface and an 18-input extended interrupt unit. See section 11 for details on the CPU.

The **memory crossbar/arbitrator** is at the heart of the system as it connects the CPU and DMA controller with the physical memories and all peripherals through the SFR bus. The memory arbitrator has four memory access points, access at which can map to one of three physical memories: an 8 KB SRAM, flash memory or RF and SFR registers. The memory arbitrator is responsible for performing arbitration and sequencing between simultaneous memory accesses to the same physical memory.

The **SFR bus** is drawn conceptually in Figure 5 as a common bus that connects all hardware peripherals to the memory arbitrator. The SFR bus in the block diagram also provides access to the radio registers in the radio register bank even though these are indeed mapped into XDATA memory space.

The **8 KB SRAM** maps to the DATA memory space and to parts of the XDATA memory spaces. 4 KB of the 8 KB SRAM is an ultra-low-power SRAM that retains its contents even when the digital part is powered off (power modes 2 and 3). The rest of the SRAM loses its contents when the digital part is powered off.

The **32/64/128 KB flash block** provides in-circuit programmable non-volatile program memory for the device and maps into the CODE and XDATA memory spaces. Table 22 shows the available devices in the **CC2430** family. The available devices differ only in flash memory size. Writing to the flash block is performed through a **flash controller** that allows page-wise (2048 byte) erasure and 4 byte-wise programming. See section 13.3 for details on the flash controller.

A versatile five-channel **DMA controller** is available in the system and accesses memory using the XDATA memory space and thus has access to all physical memories. Each channel is configured (trigger, priority, transfer mode, addressing mode, source and destination pointers, and transfer count) with DMA descriptors anywhere in memory. Many of the hardware peripherals rely on the DMA controller for efficient operation (AES core, flash write controller, USARTs, Timers, ADC interface) by performing data transfers

between a single SFR address and flash/SRAM. See section 13.5 for details.

The **interrupt controller** services a total of 18 interrupt sources, divided into six *interrupt groups*, each of which is associated with one of four interrupt priorities. An interrupt request is serviced even if the device is in a sleep mode (power modes 1-3) by bringing the **CC2430** back to active mode (power mode 0).

The **debug interface** implements a proprietary two-wire serial interface that is used for in-circuit debugging. Through this debug interface it is possible to perform an erasure of the entire flash memory, control which oscillators are enabled, stop and start execution of the user program, execute supplied instructions on the 8051 core, set code breakpoints, and single step through instructions in the code. Using these techniques it is possible to elegantly perform in-circuit debugging and external flash programming. See section 12 for details.

The **I/O-controller** is responsible for all general-purpose I/O pins. The CPU can configure whether peripheral modules control certain pins or whether they are under software control, and if so whether each pin is configured as an input or output and if a pull-up or pull-down resistor in the pad is connected. Each peripheral that connects to the I/O-pins can choose between two different I/O pin locations to ensure flexibility in various applications. See section 13.4 for details.

The **sleep timer** is an ultra-low power timer that counts 32.768 kHz crystal oscillator or 32 kHz RC oscillator periods. The sleep timer runs continuously in all operating modes except power mode 3. Typical uses for it is as a real-time counter that runs regardless of operating mode (except power mode 3) or as a wakeup timer to get out of power mode 1 or 2. See section 13.9 for details.

A built-in **watchdog timer** allows the **CC2430** to reset itself in case the firmware hangs. When enabled by software, the watchdog timer must be cleared periodically, otherwise it will reset the device when it times out. See section 13.13 for details.

**Timer 1** is a 16-bit timer with timer/counter/PWM functionality. It has a programmable prescaler, a 16-bit period value and three individually programmable counter/capture channels each with a 16-bit compare value. Each of the counter/capture channels can be used as PWM outputs or to

capture the timing of edges on input signals. See section 13.6 for details.

**MAC timer (Timer 2)** is specially designed for supporting an IEEE 802.15.4 MAC or other time-slotted protocols in software. The timer has a configurable timer period and an 8-bit overflow counter that can be used to keep track of the number of periods that have transpired. There is also a 16-bit capture register used to record the exact time at which a start of frame delimiter is received/transmitted or the exact time of which transmission ends, as well as a 16-bit output compare register that can produce various command strobes (start RX, start TX, etc) at specific times to the radio modules. See section 13.7 for details.

**Timers 3 and 4** are 8-bit timers with timer/counter/PWM functionality. They have a programmable prescaler, an 8-bit period value and one programmable counter channel with a 8-bit compare value. Each of the counter channels can be used as PWM outputs. See section 13.8 for details.

**USART 0 and 1** are each configurable as either an SPI master/slave or a UART. They provide double buffering on both RX and TX

## 9.2 Radio

**CC2430** features an IEEE 802.15.4 compliant radio based on the leading **CC2420** transceiver. See Section 14 for details.

and hardware flow-control and are thus well suited to high-throughput full-duplex applications. Each has its own high-precision baud-rate generator thus leaving the ordinary timers free for other uses. When configured as an SPI slave they sample the input signal using SCK directly instead of some over-sampling scheme and are thus well-suited to high data rates. See section 13.14 for details.

The **AES encryption/decryption core** allows the user to encrypt and decrypt data using the AES algorithm with 128-bit keys. The core is able to support the AES operations required by IEEE 802.15.4 MAC security, the ZigBee<sup>®</sup> network layer and the application layer. See section 13.12 for details.

The **ADC** supports 7 to 12 bits of resolution in a 30 kHz to 4 kHz bandwidth respectively. DC and audio conversions with up to 8 input channels (Port 0) are possible. The inputs can be selected as single ended or differential. The reference voltage can be internal, AVDD, or a single ended or differential external signal. The ADC also has a temperature sensor input channel. The ADC can automate the process of periodic sampling or conversion over a sequence of channels. See Section 13.10 for details.

**Table 22: CC2430 Flash Memory Options**

Device	Flash
CC2430F32	32 KB
CC2430F64	64 KB
CC2430F128	128 KB

## 10 Application Circuit

Few external components are required for the operation of **CC2430**. A typical application circuit is shown in Figure 6. Typical values and

description of external components are shown in Table 23.

### 10.1 Input / output matching

The RF input/output is high impedance and differential. The optimum differential load for the RF port is  $60 + j164 \Omega^4$ .

LNA (RX) and the PA (TX). See Input/output matching section on page 170 for more details.

When using an unbalanced antenna such as a monopole, a balun should be used in order to optimize performance. The balun can be implemented using low-cost discrete inductors and capacitors. The recommended balun shown, consists of C341, L341, L321 and L331 together with a PCB microstrip transmission line ( $\lambda/2$ -dipole), and will match the RF input/output to  $50 \Omega$ . An internal T/R switch circuit is used to switch between the

If a balanced antenna such as a folded dipole is used, the balun can be omitted. If the antenna also provides a DC path from TXRX\_SWITCH pin to the RF pins, inductors are not needed for DC bias.

Figure 6 shows a suggested application circuit using a differential antenna. The antenna type is a standard folded dipole. The dipole has a virtual ground point; hence bias is provided without degradation in antenna performance. Also refer to the section Antenna Considerations on page 175.

<sup>4</sup> This is for 2440MHz.

### 10.2 Bias resistors

The bias resistors are R221 and R261. The bias resistor R221 is used to set an accurate bias current for the 32 MHz crystal oscillator.

### 10.3 Crystal

An external 32 MHz crystal, XTAL1, with two loading capacitors (C191 and C211) is used for the 32 MHz crystal oscillator. See page 14 for details. The load capacitance seen by the 32 MHz crystal is given by:

$$C_L = \frac{1}{\frac{1}{C_{191}} + \frac{1}{C_{211}}} + C_{parasitic}$$

XTAL2 is an optional 32.768 kHz crystal, with two loading capacitors (C441 and C431), used for the 32.768 kHz crystal oscillator. The 32.768 kHz crystal oscillator is used in applications where you need both very low

sleep current consumption and accurate wake up times. The load capacitance seen by the 32.768 kHz crystal is given by:

$$C_L = \frac{1}{\frac{1}{C_{441}} + \frac{1}{C_{431}}} + C_{parasitic}$$

A series resistor may be used to comply with the ESR requirement.

### 10.4 Voltage regulators

The on chip voltage regulators supply all 1.8 V power supply pins and internal power supplies.

C241 and C421 are required for stability of the regulators.

### 10.5 Debug interface

The debug interface pin P2\_2 is connected through pull-up resistor R451 to the power supply. See section 12 on page 60.

10.6 Power supply decoupling and filtering

Proper power supply decoupling must be used for optimum performance. The placement and size of the decoupling capacitors and the power supply filtering are very important to achieve the best performance in an

application. TI provides a compact reference design that should be followed very closely. Refer to the section PCB Layout Recommendation on page 175.

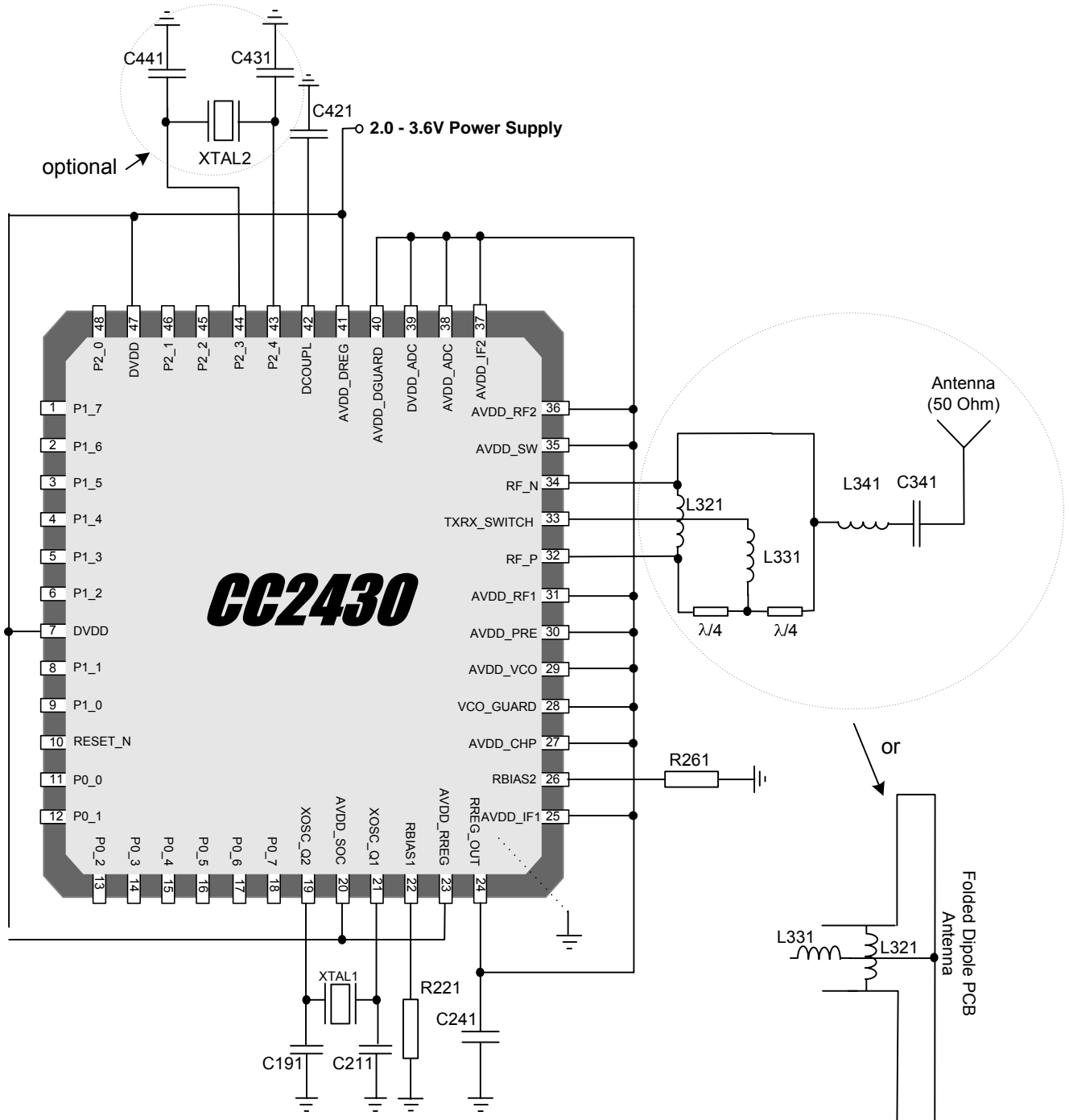

Figure 6: CC2430 Application Circuit. (Digital I/O and ADC interface not connected).  
Decoupling capacitors not shown.

**Table 23: Overview of external components (excluding supply decoupling capacitors)**

Component	Description	Single Ended 50Ω Output	Differential Antenna
C191	32 MHz crystal load capacitor	33 pF, 5%, NP0, 0402	33 pF, 5%, NP0, 0402
C211	32 MHz crystal load capacitor	27 pF, 5%, NP0, 0402	27 pF, 5%, NP0, 0402
C241	Load capacitance for analogue power supply voltage regulators	220 nF, 10%, 0402	220 nF, 10%, 0402
C421	Load capacitance for digital power supply voltage regulators	1 μF, 10%, 0402	1 μF, 10%, 0402
C341	DC block to antenna and match Note: For RF connector a LP filter can be connected between this C, the antenna and good ground in order to remove conducted spurious emission by using 1.8pF in parallel with 1.6nH	5.6 pF, 5%, NP0, 0402	Not used
		1.8 pF, Murata COG 0402, GRM15 1.6 nH, Murata 0402, LQG15HS1N6S02	
C431, C441	32.768 kHz crystal load capacitor (if low-frequency crystal is needed in application)	15 pF, 5%, NP0, 0402	15 pF, 5%, NP0, 0402
L321	Discrete balun and match	6.8 nH, 5%, Monolithic/multilayer, 0402	12 nH 5%, Monolithic/multilayer, 0402
L331	Discrete balun and match	22 nH, 5%, Monolithic/multilayer, 0402	27 nH, 5%, Monolithic/multilayer, 0402
L341	Discrete balun and match	1.8 nH, +/-0.3 nH, Monolithic/multilayer, 0402	Not used
R221	Precision resistor for current reference generator to system-on-chip part	56 kΩ, 1%, 0402	56 kΩ, 1%, 0402
R261	Precision resistor for current reference generator to RF part	43 kΩ, 1%, 0402	43 kΩ, 1%, 0402
XTAL1	32 MHz Crystal	32 MHz crystal, ESR < 60 Ω	32 MHz crystal, ESR < 60 Ω
XTAL2	Optional 32.768 kHz watch crystal (if low-frequency crystal is needed in application)	32.768 kHz crystal, Epson MC 306.	32.768 kHz crystal, Epson MC 306.

## 11 8051 CPU

This section describes the 8051 CPU core, with interrupts, memory and instruction set.

### 11.1 8051 CPU Introduction

The *CC2430* includes an 8-bit CPU core which is an enhanced version of the industry standard 8051 core.

The enhanced 8051 core uses the standard 8051 instruction set. Instructions execute faster than the standard 8051 due to the following:

- One clock per instruction cycle is used as opposed to 12 clocks per instruction cycle in the standard 8051.
- Wasted bus states are eliminated.

Since an instruction cycle is aligned with memory fetch when possible, most of the single byte instructions are performed in a single clock cycle. In addition to the speed improvement, the enhanced 8051 core also includes architectural enhancements:

- A second data pointer.
- Extended 18-source interrupt unit

The 8051 core is object code compatible with the industry standard 8051 microcontroller. That is, object code compiled with an industry standard 8051 compiler or assembler executes on the 8051 core and is functionally equivalent. However, because the 8051 core uses a different instruction timing than many other 8051 variants, existing code with timing loops may require modification. Also because the peripheral units such as timers and serial ports differ from those on a other 8051 cores, code which includes instructions using the peripheral units SFRs will not work correctly.

### 11.2 Memory

The 8051 CPU architecture has four different memory spaces. The 8051 has separate memory spaces for program memory and data memory. The 8051 memory spaces are the following (see section 11.2.1 and 11.2.2 for details):

**CODE.** A read-only memory space for program memory. This memory space addresses 64 KB.

**DATA.** A read/write data memory space, which can be directly or indirectly, accessed by a single cycle CPU instruction, thus allowing fast access. This memory space addresses 256 bytes. The lower 128 bytes of the DATA memory space can be addressed either directly or indirectly, the upper 128 bytes only indirectly.

**XDATA.** A read/write data memory space access to which usually requires 4-5 CPU instruction cycles, thus giving slow access. This memory space addresses 64 KB. Access to XDATA memory is also slower in hardware

than DATA access as the CODE and XDATA memory spaces share a common bus on the CPU core and instruction pre-fetch from CODE can thus not be performed in parallel with XDATA accesses.

**SFR.** A read/write register memory space which can be directly accessed by a single CPU instruction. This memory space consists of 128 bytes. For SFR registers whose address is divisible by eight, each bit is also individually addressable.

The four different memory spaces are distinct in the 8051 architecture, but are partly overlapping in the *CC2430* to ease DMA transfers and hardware debugger operation.

How the different memory spaces are mapped onto the three physical memories (flash program memory, 8 KB SRAM and memory-mapped registers) is described in sections 11.2.1 and 11.2.2.

#### 11.2.1 Memory Map

This section gives an overview of the memory map.

The memory map differs from the standard 8051 memory map in two important aspects, as described below.

First, in order to allow the DMA controller access to all physical memory and thus allow DMA transfers between the different 8051 memory spaces, parts of SFR and CODE memory space are mapped into the XDATA memory space.

Secondly, two alternative schemes for CODE memory space mapping can be used. The first scheme is the standard 8051 mapping where only the program memory i.e. flash memory is mapped to CODE memory space. This mapping is the default used after a device reset.

The second scheme is an extension to the standard CODE space mapping in that all physical memory is mapped to the CODE space region. This second scheme is called *unified mapping* of the CODE memory space.

Details about mapping of all 8051 memory spaces are given in the next section.

The memory map showing how the different physical memories are mapped into the CPU memory spaces is given in the figures on the following pages for 128 KB flash memory size option only. The other flash options are reduced versions of the F128 with natural limitations.

Note that for CODE memory space, the two alternative memory maps are shown; unified and non-unified (standard) mapping.

For users familiar with the 8051 architecture, the standard 8051 memory space is shown as "8051 memory spaces" in the figures.

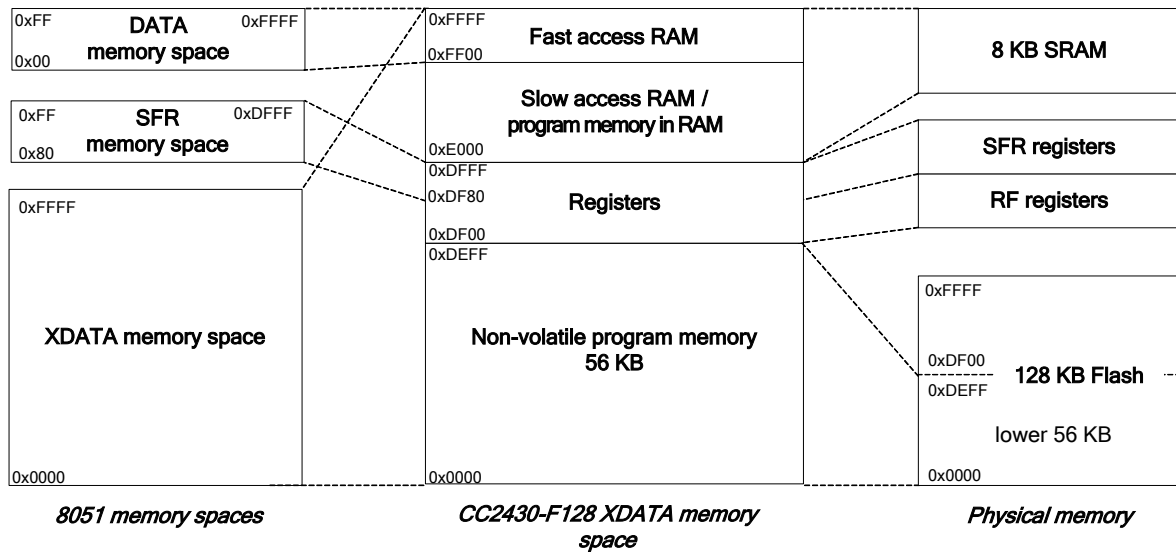

Figure 7: CC2430-F128 XDATA memory space

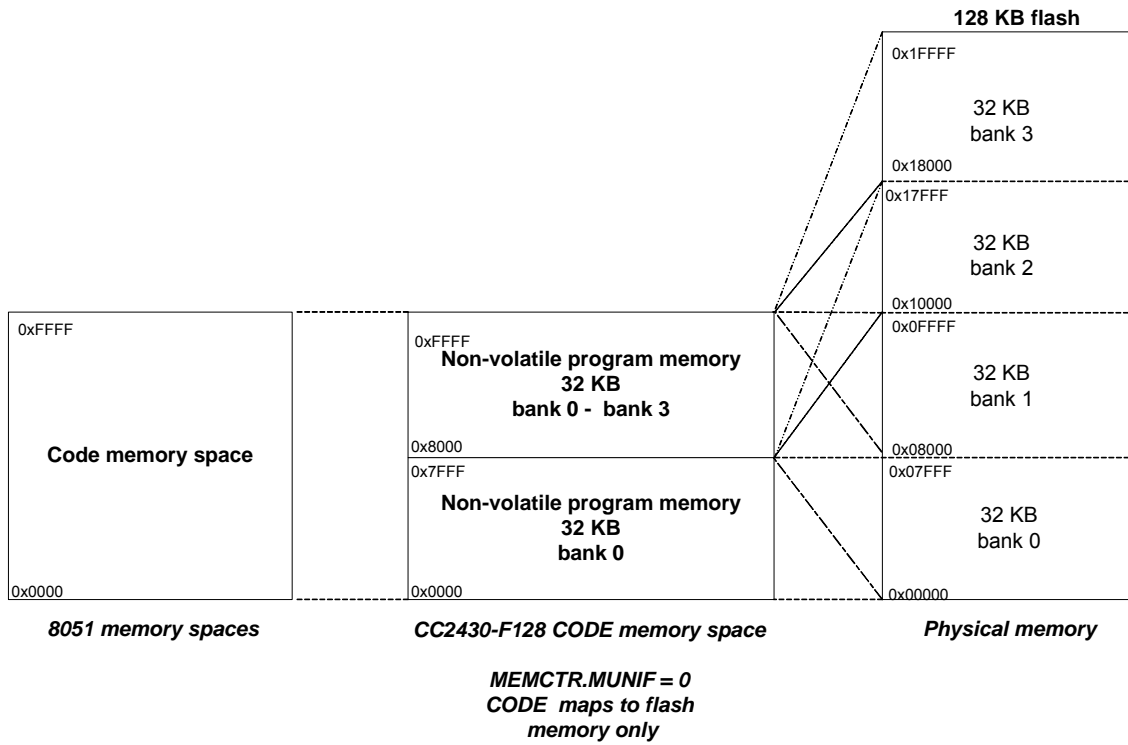

Figure 8: CC2430-F128 Non-unified mapping of CODE Space

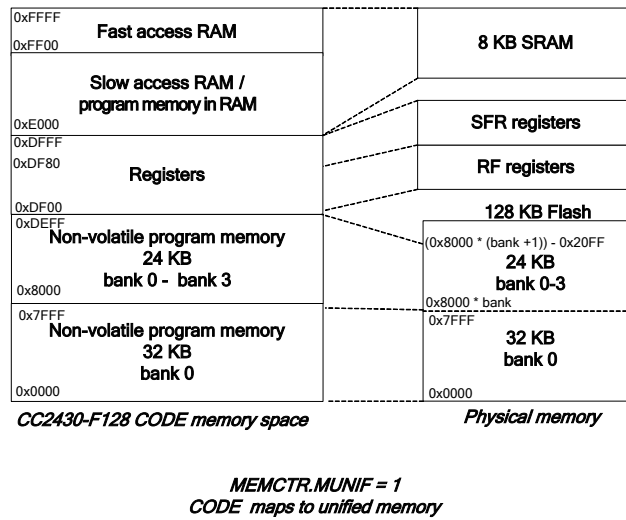

Figure 9: CC2430-F128 Unified mapping of CODE space

### 11.2.2 CPU Memory Space

This section describes the details of each CPU memory space.

**XDATA memory space.** The XDATA memory map is given in Figure 7. For devices with flash size above 32 KB only 56 KB of the flash memory is mapped into XDATA, address range 0x0000-0xDEFF. For the 32 KB flash size option, the 32 KB flash memory is mapped to 0x0000-0x7FFF in XDATA.

Access to unimplemented areas in the memory map gives an undefined result (applies to F32 only).

For all device flash-options, the 8 KB SRAM is mapped into address range 0xE000-0xFFFF.

The SFR registers are mapped into address range 0xDF80-0xDFFF, and are also equal on all flash options.

Another memory-mapped register area is the RF register area which is mapped into the address range 0xDF00-0xDF7F. These registers are associated with the radio (see sections 14 and 14.35) and are also equal on all flash options.

The mapping of flash memory, SRAM and registers to XDATA allows the DMA controller and the CPU access to all the physical memories in a single unified address space (maximum of 56 KB flash, above reserved for CODE). Note that the CODE banking scheme, described in CODE memory space section, will not affect the contents of the 24 KB above the 32KB lowest memory area, thus XDATA maps into the Flash as shown in Figure 7.

One of the ramifications of this mapping is that the first address of usable SRAM starts at address 0xE000 instead of 0x0000, and therefore compilers/assemblers must take this into consideration.

In low-power modes PM2-3 the upper 4 KB of SRAM, i.e. the memory locations in XDATA address range 0xF000-0xFFFF, will retain their contents. There are some locations in this area that are excepted from retention and thus does not keep its data in these power modes. Refer to section 13.1 on page 65 for a detailed description of power modes and SRAM data retention.

**CODE memory space.** The CODE memory space uses either a *unified* or a *non-unified* memory mapping (see section 11.2.1 on page 30) to the physical memories as shown in Figure 8 and Figure 9. The unified mapping of the CODE memory space is similar to the

XDATA mapping. Note that some SFR registers internal to the CPU can not be accessed in the unified CODE memory space (see section 11.2.3, SFR registers, on page 34).

With flash memory sizes above 32 KB, only 56 KB of flash memory is mapped to CODE memory space at a time when unified mapping is used. The upper 24 KB follows the banking scheme described below and shown in Figure 9. This is similar to the XDATA memory space except for the upper 24 KB that can change content. Using unified memory CODE data at address above 0xDEFF will not contain flash data.

The 8 KB SRAM is included in the *unified* CODE address space to allow program execution out of the SRAM.

*Note: In order to use the unified memory mapping within CODE memory space, the SFR register bit MEMCTR.MUNIF must be 1.*

For devices with flash memory size of 128 KB (CC2430F128), a flash memory banking scheme is used for the CODE memory space. For the banking scheme the upper 32 KB area of CODE memory space is mapped to one out of the four 32 KB physical blocks (banks) of flash memory. The lower 32 KB of CODE space is always mapped to the lowest 32 KB of the flash memory. The banking is controlled through the flash bank select bit (FMAP.MAP) and shown in the non-unified CODE memory map in Figure 8. The flash bank select bits reside in the SFR register bits FMAP.MAP, and also in the SFR register bits MEMCTR.FMAP, (see section 11.2.5 on page 40). The FMAP.MAP bit and MEMCTR.FMAP bit are transparent and updating one is reflected by the other.

When banking and unified CODE memory space are used, only the lower 24 KB in the selected bank is available. This is shown in Figure 9.

**DATA memory space.** The 8-bit address range of DATA memory is mapped into the upper 256 bytes of the 8 KB SRAM. This area is also accessible through the unified CODE and XDATA memory spaces at the address range 0xFF00-0xFFFF.

**SFR memory space.** The 128 entry hardware register area is accessed through this memory space. The SFR registers are also accessible through the XDATA address space at the address range 0xDF80-0xDFFF. Some CPU-

specific SFR registers reside inside the CPU core and can only be accessed using the SFR memory space and not through the duplicate

mapping into XDATA memory space. These specific SFR registers are listed in section 11.2.3, SFR registers, on page 34.

### 11.2.3 Physical memory

**RAM.** The **CC2430** contains static RAM. At power-on the contents of RAM is undefined. The RAM size is 8 KB in total. The upper 4 KB of the RAM (XDATA memory locations 0xF000-0xFFFF) retains data in all power modes (see exception below). The remaining lower 4 KB (XDATA memory locations 0xE000-0xEFFF) will lose its contents in PM2 and PM3 and contains undefined data when returning to PM0.

The memory locations 0xFD56-0xFEFF (XDATA) consists of 426 bytes in RAM that will not retain data when PM2/3 is entered.

**Flash Memory.** The on-chip flash memory consists of 32768, 65536 or 131072 bytes. The flash memory is primarily intended to hold program code. The flash memory has the following features:

- Flash page erase time: 20 ms
- Flash chip (mass) erase time: 200 ms
- Flash write time (4 bytes): 20  $\mu$ s
- Data retention<sup>5</sup>: 100 years
- Program/erase endurance: 1,000 cycles

The flash memory consists of the Flash Main Pages (up to 64 times 2 KB) which is where the CPU reads program code and data. The flash memory also contains a Flash Information Page (2 KB) which contains the Flash Lock Bits. The Flash Information Page and hence the Lock Bits is only accessed through the Debug Interface, and must be selected as source prior to access. The Flash

Controller (see section 13.3) is used to write and erase the contents of the flash main memory.

When the CPU reads instructions from flash memory, it fetches the next instruction through a cache. The instruction cache is provided mainly to reduce power consumption by reducing the amount of time the flash memory itself is accessed. The use of the instruction cache may be disabled with the `MEMCTR.CACHDIS` register bit, but doing so will increase power consumption.

**SFR Registers.** The Special Function Registers (SFRs) control several of the features of the 8051 CPU core and/or peripherals. Many of the 8051 core SFRs are identical to the standard 8051 SFRs. However, there are additional SFRs that control features that are not available in the standard 8051. The additional SFRs are used to interface with the peripheral units and RF transceiver.

Table 24 shows the address to all SFRs in **CC2430**. The 8051 internal SFRs are shown with grey background, while the other SFRs are the SFRs specific to **CC2430**.

*Note: All internal SFRs (shown with grey background in Table 24), can only be accessed through SFR space as these registers are not mapped into XDATA space.*

Table 25 lists the additional SFRs that are not standard 8051 peripheral SFRs or CPU-internal SFRs. The additional SFRs are described in the relevant sections for each peripheral function.

<sup>5</sup> At room temperature

**Table 24: SFR address overview**

8 bytes									
80	P0	SP	DPL0	DPH0	DPL1	DPH1	U0CSR	PCON	87
88	TCON	P0IFG	P1IFG	P2IFG	PICTL	P1IEN	-	P0INP	8F
90	P1	RFIM	DPS	MPAGE	T2CMP	ST0	ST1	ST2	97
98	S0CON	-	IEN2	S1CON	T2PEROF0	T2PEROF1	T2PEROF2	FMAP	9F
A0	P2	T2OF0	T2OF1	T2OF2	T2CAPLPL	T2CAPHPH	T2TLD	T2THD	A7
A8	IEN0	IP0	-	FWT	FADDRL	FADDRH	FCTL	FWDATA	AF
B0	-	ENCDI	ENCDO	ENCCS	ADCCON1	ADCCON2	ADCCON3	-	B7
B8	IEN1	IP1	ADCL	ADCH	RNDL	RNDH	SLEEP	-	BF
C0	IRCON	U0DBUF	U0BAUD	T2CNF	U0UCR	U0GCR	CLKCON	MEMCTR	C7
C8	-	WDCTL	T3CNT	T3CTL	T3CCTL0	T3CC0	T3CCTL1	T3CC1	CF
D0	PSW	DMAIRQ	DMA1CFGL	DMA1CFGH	DMA0CFGL	DMA0CFGH	DMAARM	DMAREQ	D7
D8	TIMIF	RFD	T1CC0L	T1CC0H	T1CC1L	T1CC1H	T1CC2L	T1CC2H	DF
E0	ACC	RFST	T1CNTL	T1CNTH	T1CTL	T1CCTL0	T1CCTL1	T1CCTL2	E7
E8	IRCON2	RFIF	T4CNT	T4CTL	T4CCTL0	T4CC0	T4CCTL1	T4CC1	EF
F0	B	PERCFG	ADCCFG	P0SEL	P1SEL	P2SEL	P1INP	P2INP	F7
F8	U1CSR	U1DBUF	U1BAUD	U1UCR	U1GCR	P0DIR	P1DIR	P2DIR	FF

**Table 25: CC2430 specific SFR overview**

Register name	SFR Address	Module	Description
ADCCON1	0xB4	ADC	ADC Control 1
ADCCON2	0xB5	ADC	ADC Control 2
ADCCON3	0xB6	ADC	ADC Control 3
ADCL	0xBA	ADC	ADC Data Low
ADCH	0xBB	ADC	ADC Data High
RNDL	0xBC	ADC	Random Number Generator Data Low
RNDH	0xBD	ADC	Random Number Generator Data High
ENCDI	0xB1	AES	Encryption/Decryption Input Data
ENCDO	0xB2	AES	Encryption/Decryption Output Data
ENCCS	0xB3	AES	Encryption/Decryption Control and Status
DMAIRQ	0xD1	DMA	DMA Interrupt Flag
DMA1CFGL	0xD2	DMA	DMA Channel 1-4 Configuration Address Low
DMA1CFGH	0xD3	DMA	DMA Channel 1-4 Configuration Address High
DMA0CFGL	0xD4	DMA	DMA Channel 0 Configuration Address Low
DMA0CFGH	0xD5	DMA	DMA Channel 0 Configuration Address High
DMAARM	0xD6	DMA	DMA Channel Armed
DMAREQ	0xD7	DMA	DMA Channel Start Request and Status
FWT	0xAB	FLASH	Flash Write Timing
FADDRL	0xAC	FLASH	Flash Address Low
FADDRH	0xAD	FLASH	Flash Address High
FCTL	0xAE	FLASH	Flash Control
FWDATA	0xAF	FLASH	Flash Write Data
P0IFG	0x89	IOC	Port 0 Interrupt Status Flag

Register name	SFR Address	Module	Description
P1IFG	0x8A	IOC	Port 1 Interrupt Status Flag
P2IFG	0x8B	IOC	Port 2 Interrupt Status Flag
PICTL	0x8C	IOC	Port Pins Interrupt Mask and Edge
P1IEN	0x8D	IOC	Port 1 Interrupt Mask
P0INP	0x8F	IOC	Port 0 Input Mode
PERCFG	0xF1	IOC	Peripheral I/O Control
ADCCFG	0xF2	IOC	ADC Input Configuration
P0SEL	0xF3	IOC	Port 0 Function Select
P1SEL	0xF4	IOC	Port 1 Function Select
P2SEL	0xF5	IOC	Port 2 Function Select
P1INP	0xF6	IOC	Port 1 Input Mode
P2INP	0xF7	IOC	Port 2 Input Mode
P0DIR	0xFD	IOC	Port 0 Direction
P1DIR	0xFE	IOC	Port 1 Direction
P2DIR	0xFF	IOC	Port 2 Direction
MEMCTR	0xC7	MEMORY	Memory System Control
FMAP	0x9F	MEMORY	Flash Memory Bank Mapping
RFIM	0x91	RF	RF Interrupt Mask
RFD	0xD9	RF	RF Data
RFST	0xE1	RF	RF Command Strobe
RFIF	0xE9	RF	RF Interrupt flags
ST0	0x95	ST	Sleep Timer 0
ST1	0x96	ST	Sleep Timer 1
ST2	0x97	ST	Sleep Timer 2
SLEEP	0xBE	PMC	Sleep Mode Control
CLKCON	0xC6	PMC	Clock Control
T1CC0L	0xDA	Timer1	Timer 1 Channel 0 Capture/Compare Value Low
T1CC0H	0xDB	Timer1	Timer 1 Channel 0 Capture/Compare Value High
T1CC1L	0xDC	Timer1	Timer 1 Channel 1 Capture/Compare Value Low
T1CC1H	0xDD	Timer1	Timer 1 Channel 1 Capture/Compare Value High
T1CC2L	0xDE	Timer1	Timer 1 Channel 2 Capture/Compare Value Low
T1CC2H	0xDF	Timer1	Timer 1 Channel 2 Capture/Compare Value High
T1CNTL	0xE2	Timer1	Timer 1 Counter Low
T1CNTH	0xE3	Timer1	Timer 1 Counter High
T1CTL	0xE4	Timer1	Timer 1 Control and Status
T1CCTL0	0xE5	Timer1	Timer 1 Channel 0 Capture/Compare Control
T1CCTL1	0xE6	Timer1	Timer 1 Channel 1 Capture/Compare Control
T1CCTL2	0xE7	Timer1	Timer 1 Channel 2 Capture/Compare Control
T2CMP	0x94	Timer2	Timer 2 Compare Value
T2PEROF0	0x9C	Timer2	Timer 2 Overflow Capture/Compare 0
T2PEROF1	0x9D	Timer2	Timer 2 Overflow Capture/Compare 1
T2PEROF2	0x9E	Timer2	Timer 2 Overflow Capture/Compare 2

Register name	SFR Address	Module	Description
T2OF0	0xA1	Timer2	Timer 2 Overflow Count 0
T2OF1	0xA2	Timer2	Timer 2 Overflow Count 1
T2OF2	0xA3	Timer2	Timer 2 Overflow Count 2
T2CAPLPL	0xA4	Timer2	Timer 2 Timer Period Low
T2CAPPHH	0xA5	Timer2	Timer 2 Timer Period High
T2TLD	0xA6	Timer2	Timer 2 Timer Value Low
T2THD	0xA7	Timer2	Timer 2 Timer Value High
T2CNF	0xC3	Timer2	Timer 2 Configuration
T3CNT	0xCA	Timer3	Timer 3 Counter
T3CTL	0xCB	Timer3	Timer 3 Control
T3CCTL0	0xCC	Timer3	Timer 3 Channel 0 Compare Control
T3CC0	0xCD	Timer3	Timer 3 Channel 0 Compare Value
T3CCTL1	0xCE	Timer3	Timer 3 Channel 1 Compare Control
T3CC1	0xCF	Timer3	Timer 3 Channel 1 Compare Value
T4CNT	0xEA	Timer4	Timer 4 Counter
T4CTL	0xEB	Timer4	Timer 4 Control
T4CCTL0	0xEC	Timer4	Timer 4 Channel 0 Compare Control
T4CC0	0xED	Timer4	Timer 4 Channel 0 Compare Value
T4CCTL1	0xEE	Timer4	Timer 4 Channel 1 Compare Control
T4CC1	0xEF	Timer4	Timer 4 Channel 1 Compare Value
TIMIF	0xD8	TMINT	Timers 1/3/4 Joint Interrupt Mask/Flags
U0CSR	0x86	USART0	USART 0 Control and Status
U0DBUF	0xC1	USART0	USART 0 Receive/Transmit Data Buffer
U0BAUD	0xC2	USART0	USART 0 Baud Rate Control
U0UCR	0xC4	USART0	USART 0 UART Control
U0GCR	0xC5	USART0	USART 0 Generic Control
U1CSR	0xF8	USART1	USART 1 Control and Status
U1DBUF	0xF9	USART1	USART 1 Receive/Transmit Data Buffer
U1BAUD	0xFA	USART1	USART 1 Baud Rate Control
U1UCR	0xFB	USART1	USART 1 UART Control
U1GCR	0xFC	USART1	USART 1 Generic Control
WDCTL	0xC9	WDT	Watchdog Timer Control

**RFR Registers.** The RFR registers are all related to Radio configuration and control. These registers can only be accessed through the XDATA memory space. A complete description of each register is given in section

14.35 on page 183. Table 26 gives an overview of the register address space while Table 27 gives a more descriptive overview of these registers. Note that shaded areas in Table 26 are registers for test purposes only.

**Table 26: RFR address overview (XDATA addressable with offset DF00h)**

DF+	8 bytes								DF+
00	-	-	MDMCTRL0H	MDMCTRL0L	MDMCTRL1H	MDMCTRL1L	RSSIH	RSSIL	07
08	SYNCHWORDH	SYNCWORDL	TXCTRLH	TXCTRLL	RXCTRL0H	RXCTRL0L	RXCTRL1H	RXCTRL1L	0F
10	FSCTRLH	FSCTRL	CSPX	CSPY	CSPZ	CSPCTRL	CSPT	RFPWR	17
18	-	-	-	-	-	-	-	-	1F
20	FSMTCH	FSMTCL	MANANDH	MANANDL	MANORH	MANORL	AGCCTRLH	AGCCTRL	27
28	AGCTST0H	AGCTS0L	AGCTST1H	AGCTST1L	AGCTST2H	AGCTST2L	FSTST0H	FSTST0L	2F
30	FSTST1H	FSTST1L	FSTST2H	FSTST2L	FSTST3H	FSTST3L	-	RXBPFTSTH	37
38	RXBPFTSTL	FSMSTATE	ADCTSTH	ADCTSTL	DACTSTH	DACTSTL	-	TOPTST	3F
40	RESERVEDH	RESERVEDL	-	IEEE_ADDR0	IEEE_ADDR1	IEEE_ADDR2	IEEE_ADDR3	IEEE_ADDR4	47
48	IEEE_ADDR5	IEEE_ADDR6	IEEE_ADDR7	PANIDH	PANIDL	SHORTADDRH	SHORTADDRL	IOCFG0	4F
50	IOCFG1	IOCFG2	IOCFG3	RXFIFOCNT	FSMTC1	-	-	-	57
58	-	-	-	-	-	-	-	-	5F
60	CHVER	CHIPID	RFSTATUS	-	IRQSRC	-	-	-	67
68	-	-	-	-	-	-	-	-	6F
70	-	-	-	-	-	-	-	-	77
78	-	-	-	-	-	-	-	-	7F

**Table 27 : Overview of RF registers**

XDATA Address	Register name	Description
0xDF00-0xDF01	-	Reserved
0xDF02	MDMCTRL0H	Modem Control 0, high
0xDF03	MDMCTRL0L	Modem Control 0, low
0xDF04	MDMCTRL1H	Modem Control 1, high
0xDF05	MDMCTRL1L	Modem Control 1, low
0xDF06	RSSIH	RSSI and CCA Status and Control, high
0xDF07	RSSIL	RSSI and CCA Status and Control, low
0xDF08	SYNCHWORDH	Synchronisation Word Control, high
0xDF09	SYNCWORDL	Synchronisation Word Control, low
0xDF0A	TXCTRLH	Transmit Control, high
0xDF0B	TXCTRL	Transmit Control, low
0xDF0C	RXCTRL0H	Receive Control 0, high
0xDF0D	RXCTRL0L	Receive Control 0, low
0xDF0E	RXCTRL1H	Receive Control 1, high
0xDF0F	RXCTRL1L	Receive Control 1, low
0xDF10	FSCTRLH	Frequency Synthesizer Control and Status, high
0xDF11	FSCTRL	Frequency Synthesizer Control and Status, low
0xDF12	CSPX	CSP X Data
0xDF13	CSPY	CSP Y Data
0xDF14	CSPZ	CSP Z Data
0xDF15	CSPCTRL	CSP Control

XDATA Address	Register name	Description
0xDF16	CSPT	CSP T Data
0xDF17	RFPWR	RF Power Control
0xDF20	FSMTCH	Finite State Machine Time Constants, high
0xDF21	FSMTCL	Finite State Machine Time Constants, low
0xDF22	MANANDH	Manual AND Override, high
0xDF23	MANANDL	Manual AND Override, low
0xDF24	MANORH	Manual OR Override, high
0xDF25	MANORL	Manual OR Override, low
0xDF26	AGCCTRLH	AGC Control, high
0xDF27	AGCCTRL	AGC Control, low
0xDF28-0xDF38	-	Reserved
0xDF39	FSMSTATE	Finite State Machine State Status
0xDF3A	ADCTSTH	ADC Test, high
0xDF3B	ADCTSTL	ADC Test, low
0xDF3C	DACTSTH	DAC Test, high
0xDF3D	DACTSTL	DAC Test, low
0xDF3E-0xDF41	-	Reserved
0xDF43	IEEE_ADDR0	IEEE Address 0 (LSB)
0xDF44	IEEE_ADDR1	IEEE Address 1
0xDF45	IEEE_ADDR2	IEEE Address 2
0xDF46	IEEE_ADDR3	IEEE Address 3
0xDF47	IEEE_ADDR4	IEEE Address 4
0xDF48	IEEE_ADDR5	IEEE Address 5
0xDF49	IEEE_ADDR6	IEEE Address 6
0xDF4A	IEEE_ADDR7	IEEE Address 7 (MSB)
0xDF4B	PANIDH	PAN Identifier, high
0xDF4C	PANIDL	PAN Identifier, low
0xDF4D	SHORTADDRH	Short Address, high
0xDF4E	SHORTADDRL	Short Address, low
0xDF4F	IOCFG0	I/O Configuration 0
0xDF50	IOCFG1	I/O Configuration 1
0xDF51	IOCFG2	I/O Configuration 2
0xDF52	IOCFG3	I/O Configuration 3
0xDF53	RXFIFOCNT	RX FIFO Count

XDATA Address	Register name	Description
0xDF54	FSMTC1	Finite State Machine Control
0xDF55-0xDF5F	-	Reserved
0xDF60	CHVER	Chip Version
0xDF61	CHIPID	Chip Identification
0xDF62	RFSTATUS	RF Status
0xDF63	-	Reserved
0xDF64	IRQSRC	RF Interrupt Source
0xDF65-0xDFFF	-	Reserved

#### 11.2.4 XDATA Memory Access

The **CC2430** provides an additional SFR register `MPAGE`. This register is used during instructions `MOVX A,@Ri` and `MOVX @Ri,A`. `MPAGE` gives the 8 most significant address bits, while the register `Ri` gives the 8 least significant bits.

In some 8051 implementations, this type of XDATA access is performed using `P2` to give the most significant address bits. Existing software may therefore have to be adapted to make use of `MPAGE` instead of `P2`.

#### MPAGE (0x93) – Memory Page Select

Bit	Name	Reset	R/W	Description
7:0	MPAGE[7:0]	0x00	R/W	Memory page, high-order bits of address in MOVX instruction

#### 11.2.5 Memory Arbiter

The **CC2430** includes a memory arbiter which handles CPU and DMA access to all physical memory.

The control registers `MEMCTR` and `FMAP` are used to control various aspects of the memory sub-system. The `MEMCTR` and `FMAP` registers are described below.

`MEMCTR.MUNIF` controls unified mapping of CODE memory space as shown in Figure 8 and Figure 9 on page 32. Unified mapping is required when the CPU is to execute program stored in RAM (XDATA).

For the 128 KB flash version (CC2430-F128), the Flash Bank Map register, `FMAP`, controls mapping of physical banks of the 128 KB flash to the program address region 0x8000-0xFFFF in CODE memory space as shown in Figure 8 on 32.

Please note that the `FMAP.MAP[1:0]` and `MEMCTR.FMAP[1:0]` bits are aliased. Writing to `FMAP.MAP[1:0]` will also change the contents of the `MEMCTR.FMAP[1:0]` bits, and vice versa.

## MEMCTR (0xC7) – Memory Arbiter Control

Bit	Name	Reset	R/W	Description
7	–	0	R0	Not used
6	MUNIF	0	R/W	Unified memory mapping. When unified mapping is enabled, all physical memories are mapped into the CODE memory space as far as possible, when uniform mapping is disabled only flash memory is mapped to CODE space  0 Disable unified mapping 1 Enable unified mapping
5:4	FMAP [ 1 : 0 ]	01	R/W	Flash bank map. These bits are supported by CC2430-F128 only. Controls which of the four 32 KB flash memory banks to map to program address 0x8000 – 0xFFFF in CODE memory space. These bits are aliased to FMAP . MAP [ 1 : 0 ]  00 Map program address 0x8000 – 0xFFFF to physical memory address 0x00000 – 0x07FFF 01 Map program address 0x8000 – 0xFFFF to physical memory address 0x08000– 0x0FFFF 10 Map program address 0x8000 – 0xFFFF to physical memory address 0x10000 – 0x17FFF 11 Map program address 0x8000 – 0xFFFF to physical memory address 0x18000 – 0x1FFFF
3:2	–	00	R0	Not used
1	CACHDIS	0	R/W	Flash cache disable. Invalidates contents of instruction cache and forces all instruction read accesses to read straight from flash memory. Disabling will increase power consumption and is provided for debug purposes.  0 Cache enabled 1 Cache disabled
0	–	1	R/W	Reserved. Always set to 1. <sup>6</sup>

## FMAP (0x9F) – Flash Bank Map

Bit	Name	Reset	R/W	Description
7:2	–	0x00	R0	Not used
1:0	MAP [ 1 : 0 ]	01	R/W	Flash bank map. Controls which of the four 32 KB flash memory banks to map to program address 0x8000 – 0xFFFF in CODE memory space. These bits are aliased to MEMCTR . FMAP [ 5 : 4 ]  00 Map program address 0x8000 – 0xFFFF to physical memory address 0x00000 – 0x07FFF 01 Map program address 0x8000 – 0xFFFF to physical memory address 0x08000– 0x0FFFF 10 Map program address 0x8000 – 0xFFFF to physical memory address 0x10000 – 0x17FFF 11 Map program address 0x8000 – 0xFFFF to physical memory address 0x18000 – 0x1FFFF

<sup>6</sup> Reserved bits must always be set to the specified value. Failure to follow this will result in indeterminate behaviour.

## 11.3 CPU Registers

This section describes the internal registers found in the CPU.

### 11.3.1 Data Pointers

The **CC2430** has two data pointers, DPTR0 and DPTR1 to accelerate the movement of data blocks to/from memory. The data pointers are generally used to access CODE or XDATA space e.g.

```
MOVC A, @A+DPTR
MOV A, @DPTR.
```

The data pointer select bit, bit 0 in the Data Pointer Select register **DPS**, chooses which data pointer shall be the active one during

execution of an instruction that uses the data pointer, e.g. in one of the above instructions.

The data pointers are two bytes wide consisting of the following SFRs:

- DPTR0 – DPH0 : DPL0
- DPTR1 – DPH1 : DPL1

#### DPH0 (0x83) – Data Pointer 0 High Byte

Bit	Name	Reset	R/W	Description
7:0	DPH0[7:0]	0	R/W	Data pointer 0, high byte

#### DPL0 (0x82) – Data Pointer 0 Low Byte

Bit	Name	Reset	R/W	Description
7:0	DPL0[7:0]	0	R/W	Data pointer 0, low byte

#### DPH1 (0x85) – Data Pointer 1 High Byte

Bit	Name	Reset	R/W	Description
7:0	DPH1[7:0]	0	R/W	Data pointer 1, high byte

#### DPL1 (0x84) – Data Pointer 1 Low Byte

Bit	Name	Reset	R/W	Description
7:0	DPL1[7:0]	0	R/W	Data pointer 1, low byte

#### DPS (0x92) – Data Pointer Select

Bit	Name	Reset	R/W	Description
7:1	–	0x00	R0	Not used
0	DPS	0	R/W	Data pointer select. Selects active data pointer. 0 : DPTR0 1 : DPTR1

### 11.3.2 Registers R0-R7

The **CC2430** provides four register banks (not to be confused with CODE memory space banks that only applies to flash memory organization) of eight registers each. These register banks are mapped in the DATA memory space at addresses 0x00-0x07, 0x08-

0x0F, 0x10-0x17 and 0x18-0x1F (XDATA address range 0xFF00 to 0xFF1F). Each register bank contains the eight 8-bit register R0-R7. The register bank to be used is selected through the Program Status Word PSW.RS[1:0].

### 11.3.3 Program Status Word

The Program Status Word (PSW) contains several bits that show the current state of the CPU. The Program Status Word is accessible as an SFR and it is bit-addressable. PSW is shown below and contains the Carry flag,

Auxiliary Carry flag for BCD operations, Register Select bits, Overflow flag and Parity flag. Two bits in PSW are uncommitted and can be used as user-defined status flags.

#### PSW (0xD0) – Program Status Word

Bit	Name	Reset	R/W	Description
7	CY	0	R/W	Carry flag. Set to 1 when the last arithmetic operation resulted in a carry (during addition) or borrow (during subtraction), otherwise cleared to 0 by all arithmetic operations.
6	AC	0	R/W	Auxiliary carry flag for BCD operations. Set to 1 when the last arithmetic operation resulted in a carry into (during addition) or borrow from (during subtraction) the high order nibble, otherwise cleared to 0 by all arithmetic operations.
5	F0	0	R/W	User-defined, bit-addressable
4:3	RS[1:0]	00	R/W	Register bank select bits. Selects which set of R7-R0 registers to use from four possible register banks in DATA space.  00 Register Bank 0, 0x00 – 0x07 01 Register Bank 1, 0x08 – 0x0F 10 Register Bank 2, 0x10 – 0x17 11 Register Bank 3, 0x18 – 0x1F
2	OV	0	R/W	Overflow flag, set by arithmetic operations. Set to 1 when the last arithmetic operation resulted in a carry (addition), borrow (subtraction), or overflow (multiply or divide). Otherwise, the bit is cleared to 0 by all arithmetic operations.
1	F1	0	R/W	User-defined, bit-addressable
0	P	0	R/W	Parity flag, parity of accumulator set by hardware to 1 if it contains an odd number of 1's, otherwise it is cleared to 0

### 11.3.4 Accumulator

ACC is the accumulator. This is the source and destination of most arithmetic instructions, data transfers and other instructions. The

mnemonic for the accumulator (in instructions involving the accumulator) refers to A instead of ACC.

#### ACC (0xE0) – Accumulator

Bit	Name	Reset	R/W	Description
7:0	ACC[7:0]	0x00	R/W	Accumulator

### 11.3.5 B Register

The B register is used as the second 8-bit argument during execution of multiply and divide instructions. When not used for these

purposes it may be used as a scratch-pad register to hold temporary data.

#### B (0xF0) – B Register

Bit	Name	Reset	R/W	Description
7:0	B[7:0]	0x00	R/W	B register. Used in MUL/DIV instructions.

### 11.3.6 Stack Pointer

The stack resides in DATA memory space and grows upwards. The `PUSH` instruction first increments the Stack Pointer (`SP`) and then copies the byte into the stack. The Stack Pointer is initialized to `0x07` after a reset and it is incremented once to start from location `0x08`

which is the first register (`R0`) of the second register bank. Thus, in order to use more than one register bank, the `SP` should be initialized to a different location not used for data storage.

#### SP (0x81) – Stack Pointer

Bit	Name	Reset	R/W	Description
7:0	SP[7:0]	0x07	R/W	Stack Pointer

## 11.4 Instruction Set Summary

The 8051 instruction set is summarized in Table 28. All mnemonics copyrighted © Intel Corporation, 1980.

The following conventions are used in the instruction set summary:

- `Rn` – Register `R7-R0` of the currently selected register bank.
- `direct` – 8-bit internal data location's address. This can be DATA area (`0x00 – 0x7F`) or SFR area (`0x80 – 0xFF`).
- `@Ri` – 8-bit internal data location, DATA area (`0x00 – 0xFF`) addressed indirectly through register `R1` or `R0`.
- `#data` – 8-bit constant included in instruction.
- `#data16` – 16-bit constant included in instruction.
- `addr16` – 16-bit destination address. Used by `LCALL` and `LJMP`. A branch can be anywhere within the 64 KB CODE memory space.

- `addr11` – 11-bit destination address. Used by `ACALL` and `AJMP`. The branch will be within the same 2 KB page of program memory as the first byte of the following instruction.
- `rel` – Signed (two's complement) 8-bit offset byte. Used by `SJMP` and all conditional jumps. Range is `-128` to `+127` bytes relative to first byte of the following instruction.
- `bit` – direct addressed bit in DATA area or SFR.

The instructions that affect CPU flag settings located in `PSW` are listed in Table 29 on page 49. Note that operations on the `PSW` register or bits in `PSW` will also affect the flag settings.

**Table 28: Instruction Set Summary**

Mnemonic	Description	Hex Opcode	Bytes	Cycles
<b>Arithmetic operations</b>				
ADD A,Rn	Add register to accumulator	28-2F	1	1
ADD A,direct	Add direct byte to accumulator	25	2	2
ADD A,@Ri	Add indirect RAM to accumulator	26-27	1	2
ADD A,#data	Add immediate data to accumulator	24	2	2
ADDC A,Rn	Add register to accumulator with carry flag	38-3F	1	1
ADDC A,direct	Add direct byte to A with carry flag	35	2	2
ADDC A,@Ri	Add indirect RAM to A with carry flag	36-37	1	2
ADDC A,#data	Add immediate data to A with carry flag	34	2	2
SUBB A,Rn	Subtract register from A with borrow	98-9F	1	1
SUBB A,direct	Subtract direct byte from A with borrow	95	2	2
SUBB A,@Ri	Subtract indirect RAM from A with borrow	96-97	1	2
SUBB A,#data	Subtract immediate data from A with borrow	94	2	2
INC A	Increment accumulator	04	1	1
INC Rn	Increment register	08-0F	1	2
INC direct	Increment direct byte	05	2	3
INC @Ri	Increment indirect RAM	06-07	1	3
INC DPTR	Increment data pointer	A3	1	1
DEC A	Decrement accumulator	14	1	1
DEC Rn	Decrement register	18-1F	1	2
DEC direct	Decrement direct byte	15	2	3
DEC @Ri	Decrement indirect RAM	16-17	1	3
MUL AB	Multiply A and B	A4	1	5
DIV	Divide A by B	84	1	5
DA A	Decimal adjust accumulator	D4	1	1

Mnemonic	Description	Hex Opcode	Bytes	Cycles
<b>Logical operations</b>				
ANL A,Rn	AND register to accumulator	58-5F	1	1
ANL A,direct	AND direct byte to accumulator	55	2	2
ANL A,@Ri	AND indirect RAM to accumulator	56-57	1	2
ANL A,#data	AND immediate data to accumulator	54	2	2
ANL direct,A	AND accumulator to direct byte	52	2	3
ANL direct,#data	AND immediate data to direct byte	53	3	4
ORL A,Rn	OR register to accumulator	48-4F	1	1
ORL A,direct	OR direct byte to accumulator	45	2	2
ORL A,@Ri	OR indirect RAM to accumulator	46-47	1	2
ORL A,#data	OR immediate data to accumulator	44	2	2
ORL direct,A	OR accumulator to direct byte	42	2	3
ORL direct,#data	OR immediate data to direct byte	43	3	4
XRL A,Rn	Exclusive OR register to accumulator	68-6F	1	1
XRL A,direct	Exclusive OR direct byte to accumulator	65	2	2
XRL A,@Ri	Exclusive OR indirect RAM to accumulator	66-67	1	2
XRL A,#data	Exclusive OR immediate data to accumulator	64	2	2
XRL direct,A	Exclusive OR accumulator to direct byte	62	2	3
XRL direct,#data	Exclusive OR immediate data to direct byte	63	3	4
CLR A	Clear accumulator	E4	1	1
CPL A	Complement accumulator	F4	1	1
RL A	Rotate accumulator left	23	1	1
RLC A	Rotate accumulator left through carry	33	1	1
RR A	Rotate accumulator right	03	1	1
RRC A	Rotate accumulator right through carry	13	1	1
SWAP A	Swap nibbles within the accumulator	C4	1	1

Mnemonic	Description	Hex Opcode	Bytes	Cycles
<b>Data transfers</b>				
MOV A,Rn	Move register to accumulator	E8-EF	1	1
MOV A,direct	Move direct byte to accumulator	E5	2	2
MOV A,@Ri	Move indirect RAM to accumulator	E6-E7	1	2
MOV A,#data	Move immediate data to accumulator	74	2	2
MOV Rn,A	Move accumulator to register	F8-FF	1	2
MOV Rn,direct	Move direct byte to register	A8-AF	2	4
MOV Rn,#data	Move immediate data to register	78-7F	2	2
MOV direct,A	Move accumulator to direct byte	F5	2	3
MOV direct,Rn	Move register to direct byte	88-8F	2	3
MOV direct1,direct2	Move direct byte to direct byte	85	3	4
MOV direct,@Ri	Move indirect RAM to direct byte	86-87	2	4
MOV direct,#data	Move immediate data to direct byte	75	3	3
MOV @Ri,A	Move accumulator to indirect RAM	F6-F7	1	3
MOV @Ri,direct	Move direct byte to indirect RAM	A6-A7	2	5
MOV @Ri,#data	Move immediate data to indirect RAM	76-77	2	3
MOV DPTR,#data16	Load data pointer with a 16-bit constant	90	3	3
MOVC A,@A+DPTR	Move code byte relative to DPTR to accumulator	93	1	3
MOVC A,@A+PC	Move code byte relative to PC to accumulator	83	1	3
MOVB A,@Ri	Move external RAM (8-bit address) to A	E2-E3	1	3-10
MOVX A,@DPTR	Move external RAM (16-bit address) to A	E0	1	3-10
MOVX @Ri,A	Move A to external RAM (8-bit address)	F2-F3	1	4-11
MOVX @DPTR,A	Move A to external RAM (16-bit address)	F0	1	4-11
PUSH direct	Push direct byte onto stack	C0	2	4
POP direct	Pop direct byte from stack	D0	2	3
XCH A,Rn	Exchange register with accumulator	C8-CF	1	2
XCH A,direct	Exchange direct byte with accumulator	C5	2	3
XCH A,@Ri	Exchange indirect RAM with accumulator	C6-C7	1	3
XCHD A,@Ri	Exchange low-order nibble indirect. RAM with A	D6-D7	1	3

Mnemonic	Description	Hex Opcode	Bytes	Cycles
<b>Program branching</b>				
ACALL addr11	Absolute subroutine call	xxx11	2	6
LCALL addr16	Long subroutine call	12	3	6
RET	Return from subroutine	22	1	4
RETI	Return from interrupt	32	1	4
AJMP addr11	Absolute jump	xxx01	2	3
LJMP addr16	Long jump	02	3	4
SJMP rel	Short jump (relative address)	80	2	3
JMP @A+DPTR	Jump indirect relative to the DPTR	73	1	2
JZ rel	Jump if accumulator is zero	60	2	3
JNZ rel	Jump if accumulator is not zero	70	2	3
JC rel	Jump if carry flag is set	40	2	3
JNC	Jump if carry flag is not set	50	2	3
JB bit,rel	Jump if direct bit is set	20	3	4
JNB bit,rel	Jump if direct bit is not set	30	3	4
JBC bit,direct rel	Jump if direct bit is set and clear bit	10	3	4
CJNE A,direct rel	Compare direct byte to A and jump if not equal	B5	3	4
CJNE A,#data rel	Compare immediate to A and jump if not equal	B4	3	4
CJNE Rn,#data rel	Compare immediate to reg. and jump if not equal	B8-BF	3	4
CJNE @Ri,#data rel	Compare immediate to indirect and jump if not equal	B6-B7	3	4
DJNZ Rn,rel	Decrement register and jump if not zero	D8-DF	2	3
DJNZ direct,rel	Decrement direct byte and jump if not zero	D5	3	4
NOP	No operation	00	1	1
<b>Boolean variable operations</b>				
CLR C	Clear carry flag	C3	1	1
CLR bit	Clear direct bit	C2	2	3
SETB C	Set carry flag	D3	1	1
SETB bit	Set direct bit	D2	2	3
CPL C	Complement carry flag	B3	1	1
CPL bit	Complement direct bit	B2	2	3
ANL C,bit	AND direct bit to carry flag	82	2	2
ANL C,/bit	AND complement of direct bit to carry	B0	2	2
ORL C,bit	OR direct bit to carry flag	72	2	2
ORL C,/bit	OR complement of direct bit to carry	A0	2	2
MOV C,bit	Move direct bit to carry flag	A2	2	2
MOV bit,C	Move carry flag to direct bit	92	2	3

Table 29: Instructions that affect flag settings

Instruction	CY	OV	AC
ADD	x	x	x
ADDC	x	x	x
SUBB	x	x	x
MUL	0	x	-
DIV	0	x	-
DA	x	-	-
RRC	x	-	-
RLC	x	-	-
SETB C	1	-	-
CLR C	x	-	-
CPL C	x	-	-
ANL C,bit	x	-	-
ANL C,/bit	x	-	-
ORL C,bit	x	-	-
ORL C,/bit	x	-	-
MOV C,bit	x	-	-
CJNE	x	-	-

“0”=set to 0, “1”=set to 1, “x”=set to 0/1, “-“=not affected

## 11.5 Interrupts

The CPU has 18 interrupt sources. Each source has its own request flag located in a set of Interrupt Flag SFR registers. Each interrupt requested by the corresponding flag can be individually enabled or disabled. The definitions of the interrupt sources and the interrupt vectors are given in Table 30.

The interrupts are grouped into a set of priority level groups with selectable priority levels.

The interrupt enable registers are described in section 11.5.1 and the interrupt priority settings are described in section 11.5.3 on page 57.

### 11.5.1 Interrupt Masking

Each interrupt can be individually enabled or disabled by the interrupt enable bits in the Interrupt Enable SFRs IEN0, IEN1 and IEN2. The CPU Interrupt Enable SFRs are described below and summarized in Table 30.



Note that some peripherals have several events that can generate the interrupt request associated with that peripheral. This applies to Port 0, Port 1, Port 2, Timer 1, Timer2, Timer 3, Timer 4 and Radio. These peripherals have interrupt mask bits for each internal interrupt source in the corresponding SFR registers.

In order to enable any of the interrupts in the CC2430, the following steps must be taken:

1. Clear interrupt flags
2. Set individual interrupt enable bit in the peripherals SFR register, if any.
3. Set the corresponding individual, interrupt enable bit in the IEN0, IEN1 or IEN2 registers to 1.
4. Enable global interrupt by setting the EA bit in IEN0 to 1
5. Begin the interrupt service routine at the corresponding vector address of that interrupt. See Table 30 for addresses

Figure 10 gives a complete overview of all interrupt sources and associated control and state registers. Shaded boxes are interrupt flags that are automatically cleared by HW when interrupt service routine is called. □ indicates a one-shot, either due to the level source or due to edge shaping. For the

## 8051 CPU : Interrupts

interrupts missing this they are to be treated as level triggered (apply to ports P0, P1 and P2). The switchboxes are shown in default state, and  or  indicates rising or falling edge detection, i.e. at what time instance the interrupt is generated. As a general rule for

pulsed or edge shaped interrupt sources one should clear CPU interrupt flag registers prior to clearing source flag bit, if available, for flags that are not automatically cleared. For level sources one has to clear source prior to clearing CPU flag.

**Table 30: Interrupts Overview**

Interrupt number	Description	Interrupt name	Interrupt Vector	Interrupt Mask, CPU	Interrupt Flag, CPU
0	RF TX FIFO underflow and RX FIFO overflow.	RFERR	03h	IEN0.RFERRIE	TCON.RFERRIF <sup>7</sup>
1	ADC end of conversion	ADC	0Bh	IEN0.ADCIE	TCON.ADCIF <sup>7</sup>
2	USART0 RX complete	URX0	13h	IEN0.URX0IE	TCON.URX0IF <sup>7</sup>
3	USART1 RX complete	URX1	1Bh	IEN0.URX1IE	TCON.URX1IF <sup>7</sup>
4	AES encryption/decryption complete	ENC	23h	IEN0.ENCIE	SOCON.ENCIF
5	Sleep Timer compare	ST	2Bh	IEN0.STIE	IRCON.STIF
6	Port 2 inputs	P2INT	33h	IEN2.P2IE	IRCON2.P2IF <sup>8</sup>
7	USART0 TX complete	UTX0	3Bh	IEN2.UTX0IE	IRCON2.UTX0IF
8	DMA transfer complete	DMA	43h	IEN1.DMAIE	IRCON.DMAIF
9	Timer 1 (16-bit) capture/compare/overflow	T1	4Bh	IEN1.T1IE	IRCON.T1IF <sup>7,8</sup>
10	Timer 2 (MAC Timer)	T2	53h	IEN1.T2IE	IRCON.T2IF <sup>7,8</sup>
11	Timer 3 (8-bit) compare/overflow	T3	5Bh	IEN1.T3IE	IRCON.T3IF <sup>7,8</sup>
12	Timer 4 (8-bit) compare/overflow	T4	63h	IEN1.T4IE	IRCON.T4IF <sup>7,8</sup>
13	Port 0 inputs	P0INT	6Bh	IEN1.P0IE	IRCON.P0IF <sup>8</sup>
14	USART1 TX complete	UTX1	73h	IEN2.UTX1IE	IRCON2.UTX1IF
15	Port 1 inputs	P1INT	7Bh	IEN2.P1IE	IRCON2.P1IF <sup>8</sup>
16	RF general interrupts	RF	83h	IEN2.RFIE	S1CON.RFIF <sup>8</sup>
17	Watchdog overflow in timer mode	WDT	8Bh	IEN2.WDTIE	IRCON2.WDTIF

<sup>7</sup> HW cleared when Interrupt Service Routine is called.

<sup>8</sup> Additional IRQ mask and IRQ flag bits exists.

8051 CPU : Interrupts

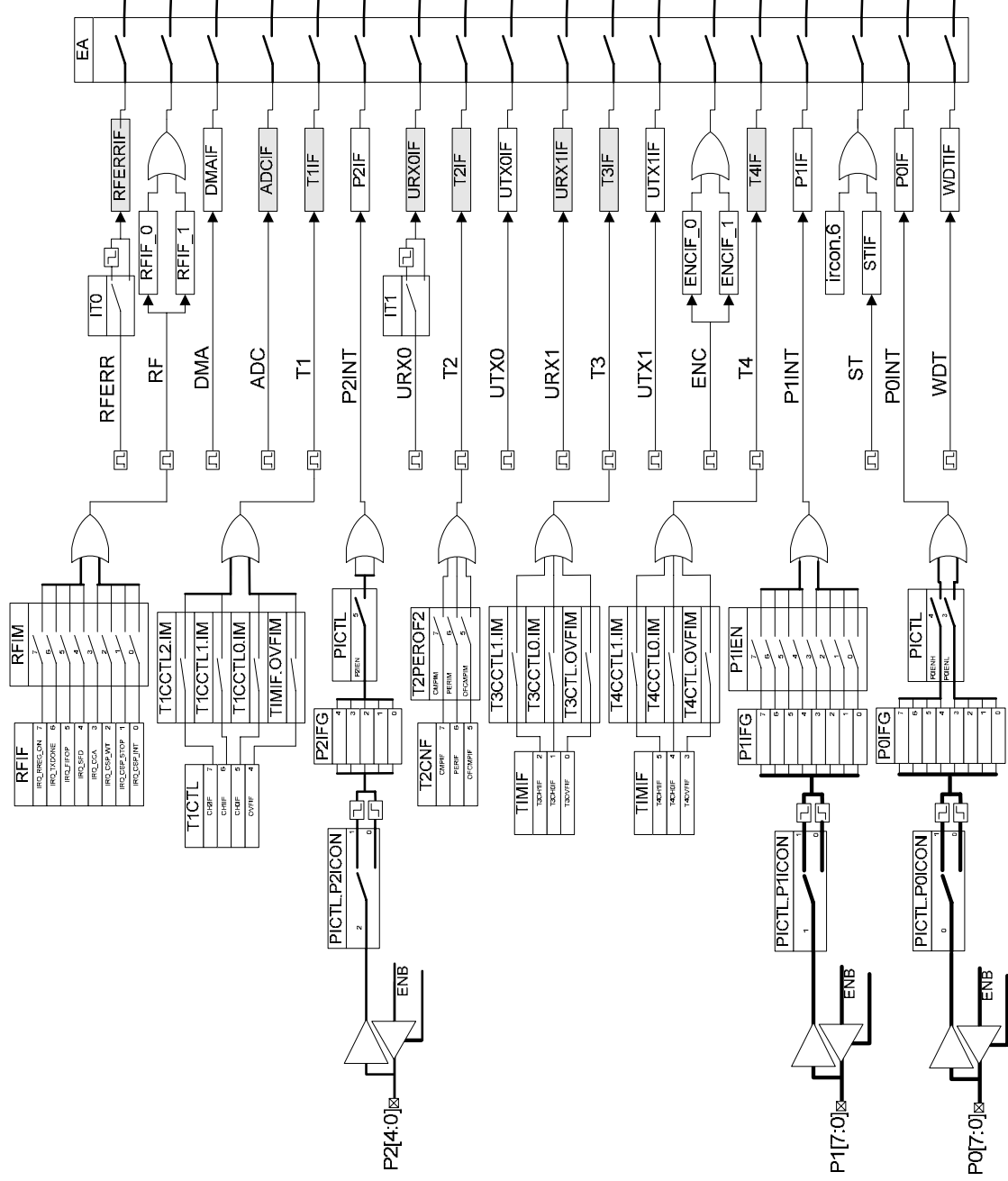

Figure 10: CC2430 interrupt overview

## IEN0 (0xA8) – Interrupt Enable 0

Bit	Name	Reset	R/W	Description
7	EA	0	R/W	Disables all interrupts. 0 No interrupt will be acknowledged 1 Each interrupt source is individually enabled or disabled by setting its corresponding enable bit
6	-	0	R0	Not used. Read as 0
5	STIE	0	R/W	STIE – Sleep Timer interrupt enable 0 Interrupt disabled 1 Interrupt enabled
4	ENCIE	0	R/W	ENCIE – AES encryption/decryption interrupt enable 0 Interrupt disabled 1 Interrupt enabled
3	URX1IE	0	R/W	URX1IE – USART1 RX interrupt enable 0 Interrupt disabled 1 Interrupt enabled
2	URX0IE	0	R/W	URX0IE - USART0 RX interrupt enable 0 Interrupt disabled 1 Interrupt enabled
1	ADCIE	0	R/W	ADCIE – ADC interrupt enable 0 Interrupt disabled 1 Interrupt enabled
0	RFERRIE	0	R/W	RFERRIE – RF TX/RX FIFO interrupt enable 0 Interrupt disabled 1 Interrupt enabled

### IEN1 (0xB8) – Interrupt Enable 1

Bit	Name	Reset	R/W	Description
7:6	-	00	R0	Not used. Read as 0
5	P0IE	0	R/W	P0IE – Port 0 interrupt enable 0 Interrupt disabled 1 Interrupt enabled
4	T4IE	0	R/W	T4IE - Timer 4 interrupt enable 0 Interrupt disabled 1 Interrupt enabled
3	T3IE	0	R/W	T3IE - Timer 3 interrupt enable 0 Interrupt disabled 1 Interrupt enabled
2	T2IE	0	R/W	T2IE – Timer 2 interrupt enable 0 Interrupt disabled 1 Interrupt enabled
1	T1IE	0	R/W	T1IE – Timer 1 interrupt enable 0 Interrupt disabled 1 Interrupt enabled
0	DMAIE	0	R/W	DMAIE – DMA transfer interrupt enable 0 Interrupt disabled 1 Interrupt enabled

### IEN2 (0x9A) – Interrupt Enable 2

Bit	Name	Reset	R/W	Description
7:6	-	00	R0	Not used. Read as 0
5	WDTIE	0	R/W	WDTIE – Watchdog timer interrupt enable 0 Interrupt disabled 1 Interrupt enabled
4	P1IE	0	R/W	P1IE– Port 1 interrupt enable 0 Interrupt disabled 1 Interrupt enabled
3	UTX1IE	0	R/W	UTX1IE – USART1 TX interrupt enable 0 Interrupt disabled 1 Interrupt enabled
2	UTX0IE	0	R/W	UTX0IE - USART0 TX interrupt enable 0 Interrupt disabled 1 Interrupt enabled
1	P2IE	0	R/W	P2IE – Port 2 interrupt enable 0 Interrupt disabled 1 Interrupt enabled
0	RFIE	0	R/W	RFIE – RF general interrupt enable 0 Interrupt disabled 1 Interrupt enabled

### 11.5.2 Interrupt Processing

When an interrupt occurs, the CPU will vector to the interrupt vector address as shown in Table 30. Once an interrupt service has begun, it can be interrupted only by a higher priority interrupt. The interrupt service is terminated by a RETI (return from interrupt instruction). When an RETI is performed, the CPU will return to the instruction that would have been next when the interrupt occurred.

When the interrupt condition occurs, the CPU will also indicate this by setting an interrupt flag bit in the interrupt flag registers. This bit is set regardless of whether the interrupt is enabled or disabled. If the interrupt is enabled when an interrupt flag is set, then on the next

instruction cycle the interrupt will be acknowledged by hardware forcing an LCALL to the appropriate vector address.

Interrupt response will require a varying amount of time depending on the state of the CPU when the interrupt occurs. If the CPU is performing an interrupt service with equal or greater priority, the new interrupt will be pending until it becomes the interrupt with highest priority. In other cases, the response time depends on current instruction. The fastest possible response to an interrupt is seven machine cycles. This includes one machine cycle for detecting the interrupt and six cycles to perform the LCALL.

### TCON (0x88) – Interrupt Flags

Bit	Name	Reset	R/W	Description
7	URX1IF	0	R/W H0	URX1IF – USART1 RX interrupt flag. Set to 1 when USART1 RX interrupt occurs and cleared when CPU vectors to the interrupt service routine.  0 Interrupt not pending 1 Interrupt pending
6	–	0	R/W	Not used
5	ADCIF	0	R/W H0	ADCIF – ADC interrupt flag. Set to 1 when ADC interrupt occurs and cleared when CPU vectors to the interrupt service routine.  0 Interrupt not pending 1 Interrupt pending
4	–	0	R/W	Not used
3	URX0IF	0	R/W H0	URX0IF – USART0 RX interrupt flag. Set to 1 when USART0 interrupt occurs and cleared when CPU vectors to the interrupt service routine.  0 Interrupt not pending 1 Interrupt pending
2	IT1	1	R/W	Reserved. Must always be set to 1. Setting a zero will enable low level interrupt detection, which is almost always the case (one-shot when interrupt request is initiated)
1	RFERRIF	0	R/W H0	RFERRIF – RF TX/RX FIFO interrupt flag. Set to 1 when RFERR interrupt occurs and cleared when CPU vectors to the interrupt service routine.  0 Interrupt not pending 1 Interrupt pending
0	IT0	1	R/W	Reserved. Must always be set to 1. Setting a zero will enable low level interrupt detection, which is almost always the case (one-shot when interrupt request is initiated)

**S0CON (0x98) – Interrupt Flags 2**

Bit	Name	Reset	R/W	Description
7:2	–	0x00	R/W	Not used
1	ENCIF_1	0	R/W	ENCIF – AES interrupt. ENC has two interrupt flags, ENCIF_1 and ENCIF_0. Setting one of these flags will request interrupt service. Both flags are set when the AES co-processor requests the interrupt.  0 Interrupt not pending 1 Interrupt pending
0	ENCIF_0	0	R/W	ENCIF – AES interrupt. ENC has two interrupt flags, ENCIF_1 and ENCIF_0. Setting one of these flags will request interrupt service. Both flags are set when the AES co-processor requests the interrupt.  0 Interrupt not pending 1 Interrupt pending

**S1CON (0x9B) – Interrupt Flags 3**

Bit	Name	Reset	R/W	Description
7:2	–	0x00	R/W	Not used
1	RFIF_1	0	R/W	RFIF – RF general interrupt. RF has two interrupt flags, RFIF_1 and RFIF_0. Setting one of these flags will request interrupt service. Both flags are set when the radio requests the interrupt.  0 Interrupt not pending 1 Interrupt pending
0	RFIF_0	0	R/W	RFIF – RF general interrupt. RF has two interrupt flags, RFIF_1 and RFIF_0. Setting one of these flags will request interrupt service. Both flags are set when the radio requests the interrupt.  0 Interrupt not pending 1 Interrupt pending

## 8051 CPU : Interrupts

**IRCON (0xC0) – Interrupt Flags 4**

Bit	Name	Reset	R/W	Description
7	STIF	0	R/W	STIF – Sleep timer interrupt flag 0 Interrupt not pending 1 Interrupt pending
6	–	0	R/W	Must be written 0. Writing a 1 will always enable interrupt source.
5	P0IF	0	R/W	P0IF – Port 0 interrupt flag 0 Interrupt not pending 1 Interrupt pending
4	T4IF	0	R/W H0	T4IF – Timer 4 interrupt flag. Set to 1 when Timer 4 interrupt occurs and cleared when CPU vectors to the interrupt service routine. 0 Interrupt not pending 1 Interrupt pending
3	T3IF	0	R/W H0	T3IF – Timer 3 interrupt flag. Set to 1 when Timer 3 interrupt occurs and cleared when CPU vectors to the interrupt service routine. 0 Interrupt not pending 1 Interrupt pending
2	T2IF	0	R/W H0	T2IF – Timer 2 interrupt flag. Set to 1 when Timer 2 interrupt occurs and cleared when CPU vectors to the interrupt service routine. 0 Interrupt not pending 1 Interrupt pending
1	T1IF	0	R/W H0	T1IF – Timer 1 interrupt flag. Set to 1 when Timer 1 interrupt occurs and cleared when CPU vectors to the interrupt service routine. 0 Interrupt not pending 1 Interrupt pending
0	DMAIF	0	R/W	DMAIF – DMA complete interrupt flag. 0 Interrupt not pending 1 Interrupt pending

8051 CPU : Interrupts

**IRCON2 (0xE8) – Interrupt Flags 5**

Bit	Name	Reset	R/W	Description
7:5	–	00	R/W	Not used
4	WDTIF	0	R/W	WDTIF – Watchdog timer interrupt flag. 0 Interrupt not pending 1 Interrupt pending
3	P1IF	0	R/W	P1IF – Port 1 interrupt flag. 0 Interrupt not pending 1 Interrupt pending
2	UTX1IF	0	R/W	UTX1IF – USART1 TX interrupt flag. 0 Interrupt not pending 1 Interrupt pending
1	UTX0IF	0	R/W	UTX0IF – USART0 TX interrupt flag. 0 Interrupt not pending 1 Interrupt pending
0	P2IF	0	R/W	P2IF – Port2 interrupt flag. 0 Interrupt not pending 1 Interrupt pending

**11.5.3 Interrupt Priority**

The interrupts are grouped into six interrupt priority groups and the priority for each group is set by the registers IP0 and IP1. In order to assign a higher priority to an interrupt, i.e. to its interrupt group, the corresponding bits in IP0 and IP1 must be set as shown in Table 31 on page 58.

The interrupt priority groups with assigned interrupt sources are shown in Table 32. Each group is assigned one of four priority levels. While an interrupt service request is in

progress, it cannot be interrupted by a lower or same level interrupt.

In the case when interrupt requests of the same priority level are received simultaneously, the polling sequence shown in Table 33 is used to resolve the priority of each request. Note that the polling sequence in Figure 10 is the algorithm found in Table 33, not that polling is among the IP bits as listed in the figure.

**IP1 (0xB9) – Interrupt Priority 1**

Bit	Name	Reset	R/W	Description
7:6	–	00	R/W	Not used.
5	IP1_IPG5	0	R/W	Interrupt group 5, priority control bit 1, refer to Table 32: Interrupt Priority Groups
4	IP1_IPG4	0	R/W	Interrupt group 4, priority control bit 1, refer to Table 32: Interrupt Priority Groups
3	IP1_IPG3	0	R/W	Interrupt group 3, priority control bit 1, refer to Table 32: Interrupt Priority Groups
2	IP1_IPG2	0	R/W	Interrupt group 2, priority control bit 1, refer to Table 32: Interrupt Priority Groups
1	IP1_IPG1	0	R/W	Interrupt group 1, priority control bit 1, refer to Table 32: Interrupt Priority Groups
0	IP1_IPG0	0	R/W	Interrupt group 0, priority control bit 1, refer to Table 32: Interrupt Priority Groups

8051 CPU : Interrupts

IP0 (0xA9) – Interrupt Priority 0

Bit	Name	Reset	R/W	Description
7:6	–	00	R/W	Not used.
5	IP0_IPG5	0	R/W	Interrupt group 5, priority control bit 0, refer to Table 32: Interrupt Priority Groups
4	IP0_IPG4	0	R/W	Interrupt group 4, priority control bit 0, refer to Table 32: Interrupt Priority Groups
3	IP0_IPG3	0	R/W	Interrupt group 3, priority control bit 0, refer to Table 32: Interrupt Priority Groups
2	IP0_IPG2	0	R/W	Interrupt group 2, priority control bit 0, refer to Table 32: Interrupt Priority Groups
1	IP0_IPG1	0	R/W	Interrupt group 1, priority control bit 0, refer to Table 32: Interrupt Priority Groups
0	IP0_IPG0	0	R/W	Interrupt group 0, priority control bit 0, refer to Table 32: Interrupt Priority Groups

Table 31: Priority Level Setting

IP1_x	IP0_x	Priority Level
0	0	0 – lowest
0	1	1
1	0	2
1	1	3 – highest

Table 32: Interrupt Priority Groups

Group	Interrupts		
IPG0	RFERR	RF	DMA
IPG1	ADC	T1	P2INT
IPG2	URX0	T2	UTX0
IPG3	URX1	T3	UTX1
IPG4	ENC	T4	P1INT
IPG5	ST	P0INT	WDT

Table 33: Interrupt Polling Sequence

Interrupt number	Interrupt name	
0	RFERR	Polling sequence 
16	RF	
8	DMA	
1	ADC	
9	T1	
2	URX0	
10	T2	
3	URX1	
11	T3	
4	ENC	
12	T4	
5	ST	
13	POINT	
6	P2INT	
7	UTX0	
14	UTX1	
15	P1INT	
17	WDT	

## 12 Debug Interface

The **CC2430** includes a debug interface that provides a two-wire interface to an on-chip debug module. The debug interface allows programming of the on-chip flash and it provides access to memory and registers contents and debug features such as breakpoints, single-stepping and register modification.

The debug interface uses the I/O pins P2\_1 as Debug Data and P2\_2 as Debug Clock during Debug mode. These I/O pins can be used as general purpose I/O only while the device is not in Debug mode. Thus the debug interface does not interfere with any peripheral I/O pins.

### 12.1 Debug Mode

Debug mode is entered by forcing two rising edge transitions on pin P2\_2 (Debug Clock) while the RESET\_N input is held low.

While in Debug mode pin P2\_1 is the Debug Data bi-directional pin and P2\_2 is the Debug Clock input pin.

### 12.2 Debug Communication

The debug interface uses an SPI-like two-wire interface consisting of the P2\_1 (Debug Data) and P2\_2 (Debug Clock) pins. Data is driven on the bi-directional Debug Data pin at the positive edge of Debug Clock and data is sampled on the negative edge of this clock.

shows a timing diagram of data on the debug interface.

Debug commands are sent by an external host and consist of 1 to 4 output bytes (including command byte) from the host and an optional input byte read by the host. Command and data is transferred with MSB first. Figure 11

The first byte of the debug command is a command byte and is encoded as follows:

- bits 7 to 3 : instruction code
- bits 2 : return input byte to host when high
- bits 1 to 0 : number of bytes from host following command byte

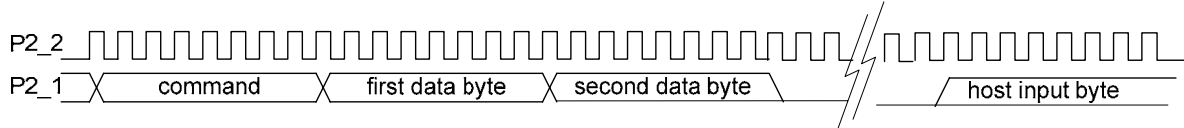

Figure 11: Debug interface timing diagram

### 12.3 Debug Commands

The debug commands are shown in Table 35.

Some of the debug commands are described in further detail in the following sub-sections.

### 12.4 Debug Lock Bit

For software and/or access protection a set of lock bits can be written. This information is contained in the Flash Information page (section 11.2.3 under **Flash memory**), at location 0x000 and the flash information page can only be accessed through the debug interface. There are three kinds of lock protect bits as described in this section.

page (page 0 ranging from address 0 to 0x07FF). When BBLOCK is set to 0, the boot sector page is locked.

The LSIZE[2:0] lock protect bits are used to define a section of the flash memory which is write protected. The size of the write protected area can be set by the LSIZE[2:0] lock bits in sizes of eight steps from 0 to 128 KB (all starting from top of flash memory and defining a section below this).

The third type of lock protect bit is DBGLOCK, which is used to disable hardware debug support through the Debug Interface. When DBGLOCK is set to 0, almost all debug commands are disabled.

The second type of lock protect bits is BBLOCK, which is used to lock the boot sector

When the Debug Lock bit, DBGLOCK is set to 0 (see Table 34) all debug commands except CHIP\_ERASE, READ\_STATUS and GET\_CHIP\_ID are disabled and will not function. The status of the Debug Lock bit can be read using the READ\_STATUS command (see section 12.4.2).

Debug Interface : Debug Lock Bit

Note that after the Debug Lock bit has changed due to a flash information page write or a flash mass erase, a HALT, RESUME, DEBUG\_INSTR or STEP command must be executed so that the Debug Lock value returned by READ\_STATUS shows the updated Debug Lock value. For example a dummy NOP DEBUG\_INSTR command could be executed. After a device reset, the Debug Lock bit will be updated. Alternatively the chip must be reset and debug mode reentered.

The CHIP\_ERASE command is used to clear the Debug Lock bit.

The lock protect bits are written as a normal flash write to FWDATA (see section 13.3.2), but

the Debug Interface needs to select the Flash Information Page first instead of the Flash Main Pages which is the default setting. The Information Page is selected through the Debug Configuration which is written through the Debug Interface only. Refer to section 12.4.1 and Table 36 for details on how the Flash Information Page is selected using the Debug Interface.

Table 34 defines the byte containing the flash lock protection bits. Note that this is not an SFR register, but instead the byte stored at location 0x000 in Flash Information Page.

Table 34: Flash Lock Protection Bits Definition

Bit	Name	Description
7:5	-	Reserved, write as 0
4	BBLOCK	Boot Block Lock 0 Page 0 is write protected 1 Page 0 is writeable, unless LSIZE is 000
3:1	LSIZE[2:0]	Lock Size. Sets the size of the upper Flash area which is write-protected. Byte sizes and page number are listed below 000 128k bytes (All pages) CC2430-F128 only 001 64k bytes (page 32 - 63) CC2430-F64/128 only 010 32k bytes (page 48 - 63) 011 16k bytes (page 56 - 63) 100 8k bytes (page 60 - 63) 101 4k bytes (page 62 - 63) 110 2k bytes (page 63) 111 0k bytes (no pages)
0	DBGLOCK	Debug lock bit 0 Disable debug commands 1 Enable debug commands

12.4.1 Debug Configuration

The commands WR\_CONFIG and RD\_CONFIG are used to access the debug configuration data byte. The format and

description of this configuration data is shown in Table 36.

12.4.2 Debug Status

A Debug status byte is read using the READ\_STATUS command. The format and description of this debug status is shown in Table 37.

CHIP\_ERASE command or oscillator stable status required for debug commands HALT, RESUME, DEBUG\_INSTR, STEP\_REPLACE and STEP\_INSTR.

The READ\_STATUS command is used e.g. for polling the status of flash chip erase after a

Debug Interface : Debug Lock Bit

**Table 35: Debug Commands**

Command	Instruction code	Description
CHIP_ERASE	0001 0000	Perform flash chip erase (mass erase) and clear lock bits. If any other command, except READ_STATUS, is issued, then the use of CHIP_ERASE is disabled.
WR_CONFIG	0001 1001	Write configuration data. Refer to Table 36 for details
RD_CONFIG	0010 0100	Read configuration data. Returns value set by WR_CONFIG command.
GET_PC	0010 1000	Return value of 16-bit program counter. Returns 2 bytes regardless of value of bit 2 in instruction code
READ_STATUS	0011 0000	Read status byte. Refer to Table 37
SET_HW_BRKPNT	0011 1111	Set hardware breakpoint
HALT	0100 0100	Halt CPU operation
RESUME	0100 1100	Resume CPU operation. The CPU must be in halted state for this command to be run.
DEBUG_INSTR	0101 01yy	Run debug instruction. The supplied instruction will be executed by the CPU without incrementing the program counter. The CPU must be in halted state for this command to be run. Note that yy is number of bytes following the command byte, i.e. how many bytes the CPU instruction has (see Table 28)
STEP_INSTR	0101 1100	Step CPU instruction. The CPU will execute the next instruction from program memory and increment the program counter after execution. The CPU must be in halted state for this command to be run.
STEP_REPLACE	0110 01yy	Step and replace CPU instruction. The supplied instruction will be executed by the CPU instead of the next instruction in program memory. The program counter will be incremented after execution. The CPU must be in halted state for this command to be run. Note that yy is number of bytes following the command byte, i.e. how many bytes the CPU instruction has (see Table 28)
GET_CHIP_ID	0110 1000	Return value of 16-bit chip ID and version number. Returns 2 bytes regardless of value of bit 2 of instruction code

Debug Interface : Debug Lock Bit

**Table 36: Debug Configuration**

Bit	Name	Description
7-4	-	Not used, must be set to zero.
3	TIMERS_OFF	Disable timers. Disable timer operation. This overrides the <code>TIMER_SUSPEND</code> bit and its function. 0 Do not disable timers 1 Disable timers
2	DMA_PAUSE	DMA pause 0 Enable DMA transfers 1 Pause all DMA transfers
1	TIMER_SUSPEND	Suspend timers. Timer operation is suspended for debug instructions and if a step instruction is a branch. If not suspended these instructions would result an extra timer count during the clock cycle in which the branch is executed 0 Do not suspend timers 1 Suspend timers
0	SEL_FLASH_INFO_PAGE	Select flash information page (2KB lowest part of flash) 0 Select flash main page (32, 64, or 128 KB) 1 Select flash information page (2KB)

**Table 37: Debug Status**

Bit	Name	Description
7	CHIP_ERASE_DONE	Flash chip erase done 0 Chip erase in progress 1 Chip erase done
6	PCON_IDLE	PCON idle 0 CPU is running 1 CPU is idle (clock gated)
5	CPU_HALTED	CPU halted 0 CPU running 1 CPU halted
4	POWER_MODE_0	Power Mode 0 0 Power Mode 1-3 selected 1 Power Mode 0 selected
3	HALT_STATUS	Halt status. Returns cause of last CPU halt 0 CPU was halted by HALT debug command 1 CPU was halted by hardware breakpoint
2	DEBUG_LOCKED	Debug locked. Returns value of <code>DBGLOCK</code> bit 0 Debug interface is not locked 1 Debug interface is locked
1	OSCILLATOR_STABLE	Oscillators stable. This bit represents the status of the <code>SLEEP.XSOC_STB</code> and <code>SLEEP.HFRC_STB</code> register bits. 0 Oscillators not stable 1 Oscillators stable
0	STACK_OVERFLOW	Stack overflow. This bit indicates when the CPU writes to <code>DATA</code> memory space at address <code>0xFF</code> which is possibly a stack overflow 0 No stack overflow 1 Stack overflow

### 12.4.3 Hardware Breakpoints

The debug command `SET_HW_BRKPNT` is used to set a hardware breakpoint. The **CC2430** supports up to four hardware breakpoints. When a hardware breakpoint is enabled it will compare the CPU address bus with the breakpoint. When a match occurs, the CPU is halted.

When issuing the `SET_HW_BRKPNT`, the external host must supply three data bytes that define the hardware breakpoint. The hardware breakpoint itself consists of 18 bits while three bits are used for control purposes. The format of the three data bytes for the `SET_HW_BRKPNT` command is as follows.

Debug Interface : Debug interface and Power Modes

The first data byte consists of the following:

- bits 7-5 : unused
- bits 4-3 : breakpoint number; 0-3
- bit 2 : 1=enable, 0=disable
- bits 1-0 : Memory bank bits. Bits 17-16 of hardware breakpoint.

The second data byte consists of bits 15-8 of the hardware breakpoint.

The third data byte consists of bits 7-0 of the hardware breakpoint. Thus the second and third data byte sets the CPU CODE address to stop execution at.

12.4.4 *Flash Programming*

Programming of the on-chip flash is performed via the debug interface. The external host must initially send instructions using the DEBUG\_INSTR debug command to perform

the flash programming with the Flash Controller as described in section 13.3 on page 71.

**12.5 Debug interface and Power Modes**

The debug interface can be used in all power modes, but with limitations. When enabling a power mode the system will act as normally with the exception that the digital voltage regulator is not turned off, thus power consumption when debugging power modes is higher than expected. The limitation when

debugging power modes 2 and 3 is that the chip will stop operating when woke up, thus a HALT and a RESUME command is needed to continue the SW execution. Please note that PM1 works as expected, also after chip is woke up.

## 13 Peripherals

In the following sub-sections each **CC2430** peripheral is described in detail.

### 13.1 Power Management and clocks

This section describes the Power Management Controller. The Power Management Controller controls the use of

power modes and clock control to achieve low-power operation.

#### 13.1.1 Power Management Introduction

The **CC2430** uses different operating modes, or power modes, to allow low-power operation. Ultra-low-power operation is obtained by turning off power supply to modules to avoid static (leakage) power consumption and also by using clock gating and turning off oscillators to reduce dynamic power consumption.

The various operating modes are enumerated and are to be designated as power modes 0, 1, 2, and 3 (PM0..3).

The **CC2430** four major power modes are called PM0, PM1, PM2 and PM3. PM0 is the active mode while PM3 has the lowest power consumption. The power modes impact on system operation is shown in Table 38, together with voltage regulator and oscillator options.

**PM0** : The full functional mode. The voltage regulator to the digital core is on and either the 16 MHz RC oscillator or the 32 MHz crystal oscillator or both are running. Either the 32.753 kHz RC oscillator or the 32.768 kHz crystal oscillator is running.

**PM1** : The voltage regulator to the digital part is on. Neither the 32 MHz crystal oscillator nor the 16 MHz RC oscillator are running. Either the 32.753 kHz RC oscillator or the 32.768 kHz crystal oscillator is running. The system will go to PM0 on reset or an external interrupt or when the sleep timer expires.

**PM2** : The voltage regulator to the digital core is turned off. Neither the 32 MHz crystal oscillator nor the 16 MHz RC oscillator are running. Either the 32.768 kHz RC oscillator or the 32.753 kHz crystal oscillator is running. The system will go to PM0 on reset or an external interrupt or when the sleep timer expires.

**PM3** : The voltage regulator to the digital core is turned off. None of the oscillators are running. The system will go to PM0 on reset or an external interrupt.

Table 38: Power Modes

Power Mode	High-frequency oscillator	Low-frequency oscillator	Voltage regulator (digital)
Configuration	A None	A None	
	B 32 MHz XOSC	B 32.753 kHz RCOSC	
	C 16 MHz RCOSC	C 32.768 kHz XOSC	
PM0	B, C	B or C	ON
PM1	A	B or C	ON
PM2	A	B or C	OFF
PM3	A	A	OFF

*Note: The voltage regulator above refers to the digital regulator. The analog voltage regulator must be disabled separately through the RF register RFPWR.*

#### 13.1.1.1 PM0

PM0 is the full functional mode of operation where the CPU, peripherals and RF transceiver are active. The digital voltage regulator is turned on. This is also referred to as active mode.

PM0 is used for normal operation. It should be noted that by enabling the `PCON.IDLE` bit

while in PM0 (`SLEEP.MODE=0x00`) the CPU core stops from operating. All other peripherals will function as normal and CPU core will be waked up by any enabled interrupt.

13.1.1.2 *PM1*

In PM1, the high-frequency oscillators are powered down (32MHz XOSC and 16MHz RC OSC). The voltage regulator and the enabled 32 kHz oscillator is on. When PM1 is entered, a power down sequence is run. When the device is taken out of PM1 to PM0, the high-frequency oscillators are started. The device

will run on the 16MHz RC oscillator until 32MHz is selected as source by SW.

PM1 is used when the expected time until a wakeup event is relatively short (less than 3 ms) since PM1 uses a fast power down/up sequence.

13.1.1.3 *PM2*

PM2 has the second lowest power consumption. In PM2 the power-on reset, external interrupts, 32.768 kHz oscillator and sleep timer peripherals are active. I/O pins retain the I/O mode and output value set before entering PM2. All other internal circuits are powered down. The voltage regulator is also turned off. When PM2 is entered, a power down sequence is run.

PM2 is typically entered when using the sleep timer as the wakeup event, and also combined with external interrupts. PM2 should typically be chosen, compared to PM1, when sleep times exceeds 3 ms. Using less sleep time will not reduce system power consumption compared to using PM1.

13.1.1.4 *PM3*

PM3 is used to achieve the operating mode with the lowest power consumption. In PM3 all internal circuits that are powered from the voltage regulator are turned off (basically all digital modules, the only exception are interrupt detection and POR level sensing). The internal voltage regulator and all oscillators are also turned off.

PM3. A reset condition or an enabled external IO interrupt event will wake the device up and place it into PM0 (an external interrupt will start from where it entered PM3, while a reset returns to start of program execution). The content of RAM and registers is partially preserved in this mode (see section 13.1.6). PM3 uses the same power down/up sequence as PM2.

Reset (POR or external) and external I/O port interrupts are the only functions that are operating in this mode. I/O pins retain the I/O mode and output value set before entering

PM3 is used to achieve ultra low power consumption when waiting for an external event.

13.1.2 *Power Management Control*

The required power mode is selected by the MODE bits in the SLEEP control register. Setting the SFR register PCON.IDLE bit after setting the MODE bits, enters the selected sleep mode.

An enabled interrupt from port pins or sleep timer or a power-on reset will wake the device from other power modes and bring it into PM0 by resetting the MODE bits.

13.1.3 *Power Management Registers*

This section describes the Power Management registers. All register bits retain

their previous values when entering PM2 or PM3 unless otherwise stated.

## PCON (0x87) – Power Mode Control

Bit	Name	Reset	R/W	Description
7:2	–	0x00	R/W	Not used.
1	–	0	R0	Not used, always read as 0.
0	IDLE	0	R0/W H0	Power mode control. Writing a 1 to this bit forces <b>CC2430</b> to enter the power mode set by <b>SLEEP.MODE</b> (note that <b>MODE = 0x00</b> will stop CPU core, no peripherals, activity when this bit is enabled). This bit is always read as 0  All enabled interrupts will clear this bit when active and <b>CC2430</b> will reenter PM0.

## SLEEP (0xBE) – Sleep Mode Control

Bit	Name	Reset	R/W	Description
7	OSC32K_CALDIS	0	R/W	Disable 32 kHz RC oscillator calibration 0 – 32 kHz RC oscillator calibration is enabled 1 – 32 kHz RC oscillator calibration is disabled.  The setting of this bit to 1 does not take effect until high-frequency RC oscillator is chosen as source for system clock, i.e. <b>CLKCON.OSC</b> set to 1.  Note: this bit is not retained in PM2 and PM3. After re-entry to PM0 from PM2 or PM3 this bit will be at the reset value 0
6	XOSC_STB	0	R	XOSC stable status: 0 – XOSC is not powered up or not yet stable 1 – XOSC is powered up and stable.  Note that an additional wait time of 64 $\mu$ s is needed after this bit has been set until true stable state is reached.
5	HFRC_STB	0	R	High-frequency RC oscillator (HF RCOSC) stable status: 0 – HF RCOSC is not powered up or not yet stable 1 – HF RCOSC is powered up and stable
4:3	RST[1:0]	XX	R	Status bit indicating the cause of the last reset. If there are multiple resets, the register will only contain the last event. 00 – Power-on reset 01 – External reset 10 – Watchdog timer reset
2	OSC_PD	1	R/W H0	High-frequency (32 MHz) crystal oscillator and High-frequency (16 MHz) RC oscillator power down setting. If there is a calibration in progress and the CPU attempts to set this bit, the bit will be updated at the end of calibration: 0 – Both oscillators powered up 1 – Oscillator not selected by <b>CLKCON.OSC</b> bit powered down
1:0	MODE[1:0]	00	R/W	Power mode setting: 00 – Power mode 0 01 – Power mode 1 10 – Power mode 2 11 – Power mode 3

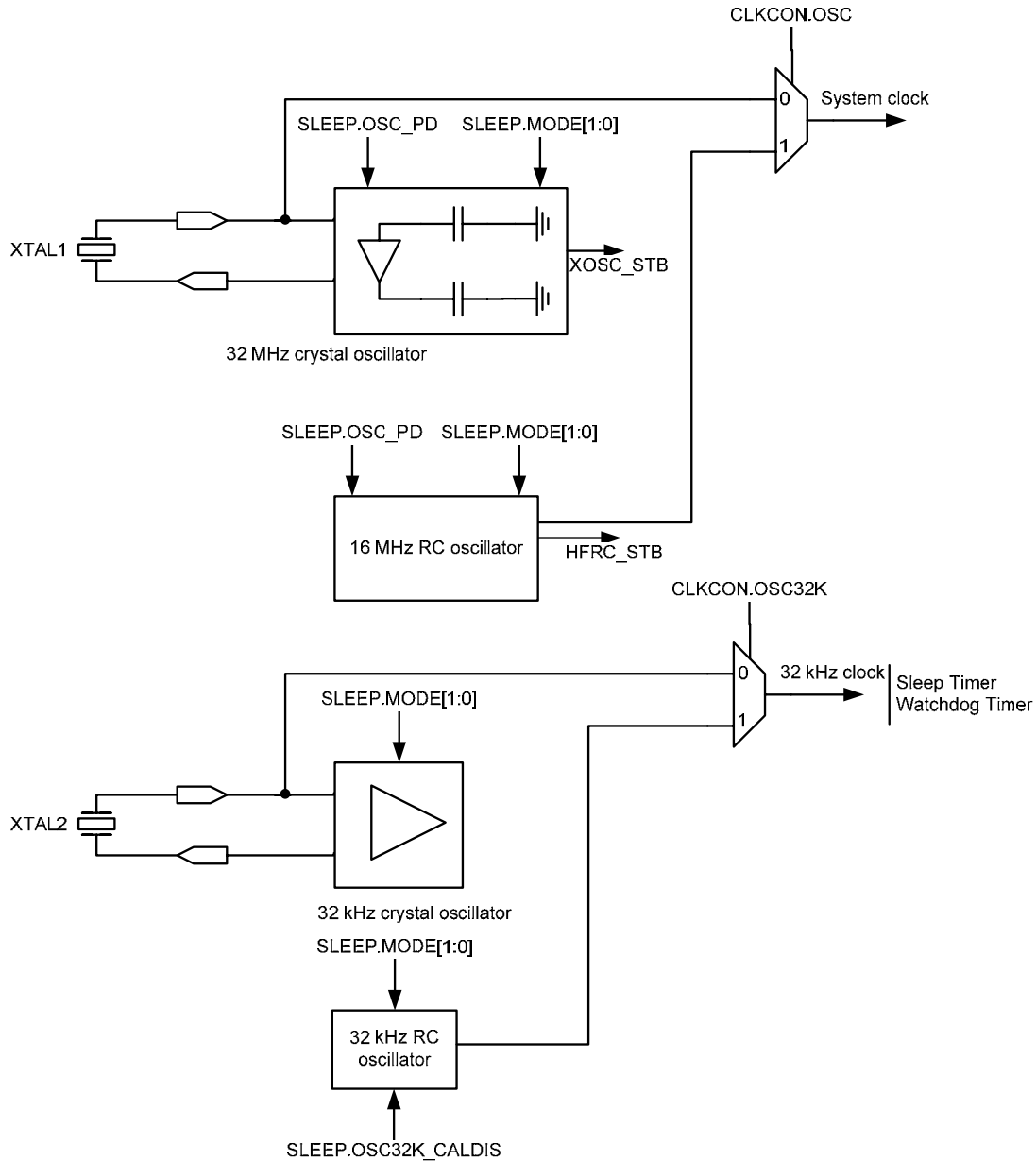

Figure 12: Clock System Overview

### 13.1.4 Oscillators and clocks

The **CC2430** has one internal system clock. The source for the system clock can be either a 16 MHz RC oscillator or a 32 MHz crystal oscillator. Clock control is performed using the CLKCON SFR register.

The system clock also feeds all 8051 peripherals (as described in section 6).

There is also one 32 kHz clock source that can either be a RC oscillator or a crystal oscillator, also controlled by the CLKCON register.

The choice of oscillator allows a trade-off between high-accuracy in the case of the crystal oscillator and low power consumption when the RC oscillator is used. Note that operation of the RF transceiver requires that the 32 MHz crystal oscillator is used.

#### 13.1.4.1 Oscillators

Figure 12 gives an overview of the clock system with available clock sources.

Two high frequency oscillators are present in the device:

- 32 MHz crystal oscillator.
- 16 MHz RC oscillator.

The 32 MHz crystal oscillator startup time may be too long for some applications, therefore the device can run on the 16 MHz RC oscillator until crystal oscillator is stable. The 16 MHz RC oscillator consumes less power than the crystal oscillator, but since it is not as accurate as the crystal oscillator it can not be used for RF transceiver operation.

Two low frequency oscillators are present in the device:

- 32 kHz crystal oscillator
- 32 kHz RC oscillator

### 13.1.4.2 System clock

The system clock is derived from the selected system clock source, which is the 32 MHz crystal oscillator or the 16 MHz RC oscillator. The `CLKCON.OSC` bit selects the source of the system clock. Note that to use the RF transceiver the 32 MHz crystal oscillator must be selected and stable.

Note that changing the `CLKCON.OSC` bit does not happen instantaneously. This is caused by the requirement to have stable clocks prior to actually changing the clock source. Also note that `CLKCON.CLKSPD` bit reflect the frequency of the system clock and thus is a mirror of the `CLKCON.OSC` bit.

When the `SLEEP.XOSC_STB` is 1, the 32 MHz crystal oscillator is reported stable by the system. This may however not be the case and a safety time of additional 64  $\mu$ s should be used prior to selecting 32 MHz clock as source for the system clock. Failure to do so may lead

### 13.1.4.3 32 kHz oscillators

Two 32 kHz oscillators are present in the device as clock sources for the 32 kHz clock:

- 32.768 kHz crystal oscillator
- 32 kHz RC oscillator

By default, after a reset, the 32 kHz RC oscillator is enabled and selected as the 32 kHz clock source. The RC oscillator consumes less power, but is less accurate than the 32.768 kHz crystal oscillator. Refer to Table 9 and Table 10 on page 15 for characteristics of these oscillators. The 32 kHz clock runs the Sleep Timer and Watchdog Timer and used as a strobe in Timer2 (MAC timer) for when to calculate Sleep Timer sleep time. Selecting which oscillator source to use as source for the 32 kHz is performed with the `CLKCON.OSC32K` register bit.

The 32 kHz crystal oscillator is designed to operate at 32.768 kHz and provide a stable clock signal for systems requiring time accuracy. The 32 kHz RC oscillator run at 32.753 kHz when calibrated. The calibration can only take place when 32 MHz crystal oscillator is enabled, and this calibration can be disabled by enabling the `SLEEP.OSC32K_CALDIS` bit. The 32 kHz RC oscillator should be used to reduce cost and power consumption compared to the 32 kHz crystal oscillator solution. The two low frequency oscillators can not be operated simultaneously.

to system crash. E.g. a loop of CPU NOP instructions should be used to suspend further system operation prior to selecting XOSC as clock source.

The oscillator not selected as the system clock source, will be set in power-down mode by setting `SLEEP.OSC_PD` to 1 (the default state). Thus the 16MHz RC oscillator may be turned off when the 32 MHz crystal oscillator has been selected as system clock source and vice versa. When `SLEEP.OSC_PD` is 0, both oscillators are powered up and running.

When the 32 MHz crystal oscillator is selected as system clock source and the 16 MHz RC oscillator is also powered up, the 16 MHz RC oscillator will be continuously calibrated to ensure clock stability over supply voltage and operating temperature. This calibration is not performed when the 16 MHz RC oscillator itself is chosen as system clock source.

The `CLKCON.OSC32K` register bit must only be changed while using the 16 MHz RC oscillator as the system clock source. When the 32 MHz crystal oscillator is selected and it is stable, i.e. `SLEEP.XOSC_STB` is 1, calibration of the 32 kHz RC oscillator is continuously performed and 32kHz clock is derived from 32 MHz clock. This calibration is not performed in other power modes than PM0. The result of the calibration is a RC clock running at 32.753 kHz.

The 32 kHz RC oscillator calibration may take up to 2 ms to complete. When entering low power modes PM1 or PM2 an ongoing calibration must be completed before the low power mode is entered. In some applications this extra delay may be unacceptable and

Peripherals : Power Management and clocks

therefore the calibration may be disabled by setting register bit `SLEEP.OSC32K_CALDIS` to 1. Note that any ongoing calibration will be

completed when a 1 is written to `SLEEP.OSC32K_CALDIS`.

13.1.4.4 Oscillator and Clock Registers

This section describes the Oscillator and Clock registers. All register bits retain their previous

values when entering PM2 or PM3 unless otherwise stated.

**CLKCON (0xC6) – Clock Control**

Bit	Name	Reset	R/W	Description
7	OSC32K	1	R/W	32 kHz clock oscillator select. The 16 MHz high frequency RC oscillator must be selected as system clock source when this bit is to be changed. 0 – 32.768 kHz crystal oscillator 1 – 32 kHz RC oscillator Note: this bit is not retained in PM2 and PM3. After re-entry to PM0 from PM2 or PM3 this bit will be at the reset value 1.
6	OSC	1	R/W	System clock oscillator select: 0 – 32 MHz crystal oscillator 1 – 16 MHz high frequency RC oscillator This setting will only take effect when the selected oscillator is powered up and stable. If the XOSC oscillator is not powered up, it should be enabled by <code>SLEEP.OSC_PD</code> bit prior to selecting it as source. Note that there is an additional wait time (64 $\mu$ s) from <code>SLEEP.XOSC_STB</code> set until XOSC can be selected as source. If RC osc is to be the source and it is powered down, setting this bit will turn it on.
5:3	TICKSPD[2:0]	001	R/W	Timer ticks output setting, can not be higher than system clock setting given by OSC bit setting 000 – 32 MHz 001 – 16 MHz 010 – 8 MHz 011 – 4 MHz 100 – 2 MHz 101 – 1 MHz 110 – 500 kHz 111 – 250 kHz
2:1	–	00	R	Reserved.
0	CLKSPD	1	R	Clock Speed. Indicates current system clock frequency. The value of this bit is set by the OSC bit setting 0 – 32 MHz 1 – 16 MHz This bit is updated when clock source selected with the OSC is stable

13.1.5 Timer Tick generation

The power management controller generates a tick or enable signal for the peripheral timers, thus acting as a prescaler for the timers. This is a global clock division for Timer 1, Timer 3 and Timer 4. The tick speed is

programmed from 0.25 MHz to 32 MHz in the `CLKCON.TICKSPD` register. It should be noted that `TICKSPD` must not be set to a higher frequency than system clock.

13.1.6 Data Retention

In power modes PM2 and PM3, power is removed from most of the internal circuitry. However parts of SRAM will retain its contents. The content of internal registers is also retained in PM2 and PM3.

The XDATA memory locations 0xF000-0xFFFF (4096 bytes) retains data in PM2 and PM3. Please note the exception as given below.

The XDATA memory locations 0xE000-0xFFFF (4096 bytes) and the area 0xFD56-

Peripherals : Reset

0xFEFF (426 bytes) will lose all data when PM2 or PM3 is entered. These locations will contain undefined data when PM0 is re-entered.

The registers which retain their contents are the CPU registers, peripheral registers and RF registers, unless otherwise specified for a given register bit field. Switching to the low-power modes PM2 or PM3 appears

13.2 Reset

The CC2430 has four reset sources. The following events generate a reset:

- Forcing RESET\_N input pin low
- A power-on reset condition
- A brown-out reset condition
- Watchdog timer reset condition

The initial conditions after a reset are as follows:

transparent to software with the following exceptions:

- The RF TXFIFO/RXFIFO contents are not retained when entering PM2 or PM3.
- Watchdog timer 15-bit counter is reset to 0x0000 when entering PM2 or PM3.

- I/O pins are configured as inputs with pull-up
- CPU program counter is loaded with 0x0000 and program execution starts at this address
- All peripheral registers are initialized to their reset values (refer to register descriptions)
- Watchdog timer is disabled

13.2.1 Power On Reset and Brown Out Detector

The CC2430 includes a Power On Reset (POR) providing correct initialization during device power-on. Also includes is a Brown Out Detector (BOD) operating on the regulated 1.8V digital power supply only, The BOD will protect the memory contents during supply voltage variations which cause the regulated 1.8V power to drop below the minimum level required by flash memory and SRAM.

When power is initially applied to the CC2430 the Power On Reset (POR) and Brown Out Detector (BOD) will hold the device in reset

state until the supply voltage reaches above the Power On Reset and Brown Out voltages.

Figure 13 shows the POR/BOD operation with the 1.8V (typical) regulated supply voltage together with the active low reset signals BOD\_RESET and POR\_RESET shown in the bottom of the figure (note that signals are not available, just for illustration of events).

The cause of the last reset can read from the register bits SLEEP.RST. It should be noted that a BOD reset will be read as a POR reset.

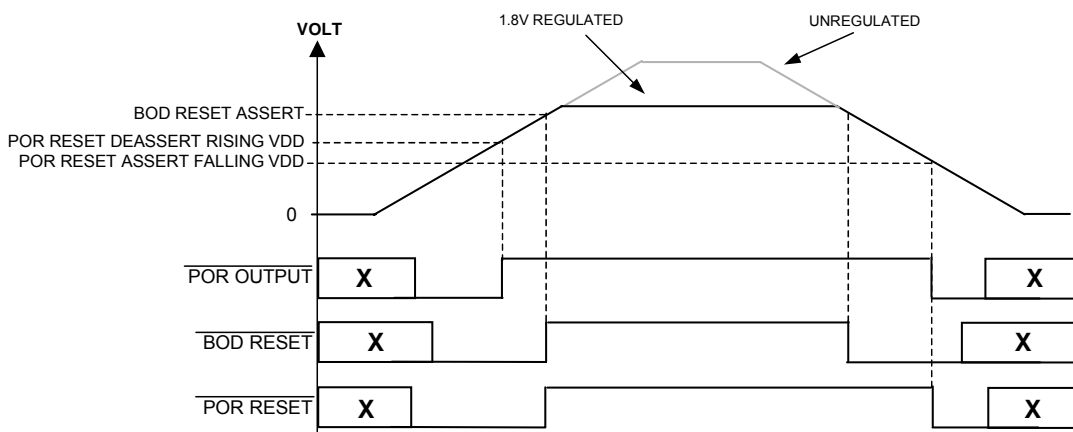

Figure 13 : Power On Reset and Brown Out Detector Operation

13.3 Flash Controller

The CC2430 contains 32, 64 or 128 KB flash memory for storage of program code. The flash memory is programmable from the user

software and through the debug interface. See Table 22 on page 26 for flash memory size options.

Peripherals : Flash Controller

The Flash Controller handles writing and erasing the embedded flash memory. The embedded flash memory consists of 64 pages of 2048 bytes each (CC2430F128).

The flash controller has the following features:

- 32-bit word programmable
- Page erase

13.3.1 *Flash Memory Organization*

The flash memory is divided into 64 flash pages consisting of 2 KB each (all versions have 2 KB pages, but the number of pages differs and here 128 KB is referred). A flash page is the smallest erasable unit in the memory, while a 32 bit word is the smallest writable unit that may be addressed through the flash controller.

When performing write operations, the flash memory is word-addressable using a 15-bit address written to the address registers FADDRH : FADDRL.

13.3.2 *Flash Write*

Data is written to the flash memory by using a program command initiated by writing the Flash Control register, FCTL. Flash write operations can program any number of words in the flash memory, single words or block of words in sequence starting at start address (set by FADDRH : FADDRL). Each location may be programmed twice before the next erase must take place, meaning that a bit in a word can change from 1-1 or 1-0 but not 0-1 (writing a 0 to 1 will be ignored). This can be utilized by writing to different parts of the word with masking without having to do a page erase before writing. After a page erase or chip erase (through debug interface), the erased bits are set to 1.

A write operation is performed using one out of two methods;

- Through DMA transfer
- Through CPU SFR access.

The DMA transfer method is the preferred way to write to the flash memory.

A write operation is initiated by writing a 1 to FCTL.WRITE. The start address for writing the 32-bit word is given by FADDRH : FADDRL. During each single write operation FCTL.SWBSY is set high. During a write operation, the byte written to the FWDATA

- Lock bits for write-protection and code security
- Flash page erase timing 20 ms
- Flash chip erase timing 200 ms
- Flash write timing (4 bytes) 20 μs
- Auto power-down during low-frequency CPU clock read access

When performing page erase operations, the flash memory page to be erased is addressed through the register bits FADDRH[6 : 1].

Note the difference in addressing the flash memory; when accessed by the CPU to read code or data, the flash memory is byte-addressable. When accessed by the Flash Controller, the flash memory is word-addressable, where a word consists of 32 bits.

The next sections describe the procedures for flash write and flash page erase in detail.

register is forwarded to the flash memory. The flash memory is 32-bit word-programmable, meaning data is written as 32-bit words. The first byte written to FWDATA is the LSB of the 32-bit word. The actual writing to flash memory takes place each time four bytes have been written to FWDATA, meaning that all Flash writes must be 4 bytes aligned.

The CPU will not be able to access the flash, e.g. to read program code, while a flash write operation is in progress. Therefore the program code executing the flash write must be executed from RAM, meaning that the program code must reside in the area 0xE000 to 0xFEFF in Unified CODE memory space.

When a flash write operation is executed from RAM, the CPU continues to execute code from the next instruction after initiation of the flash write operation (FCTL.WRITE=1).

The FCTL.SWBSY bit must be 0 before accessing the flash after a flash write, otherwise an access violation occurs. This also means that FCTL.SWBSY must be 0 before program execution can continue from a location in flash memory.

### 13.3.2.1 DMA Flash Write

When using DMA write operations, the data to be written into flash is stored in the XDATA memory space (RAM or FLASH). A DMA channel is configured to read the data to be written from memory, source address, and write this data to the Flash Write Data register, `FWDATA`, fixed destination address, with the DMA trigger event `FLASH` (`TRIG[4:0]=10010` in DMA configuration) enabled. Thus the Flash Controller will trigger a DMA transfer when the Flash Write Data register, `FWDATA`, is ready to receive new data. The DMA channel should be configured to perform single mode, byte size transfers with source address set to start of data block and destination address to fixed `FWDATA` (note that the block size, `LEN` in configuration data, must be 4 bytes aligned). High priority should also be ensured for the DMA channel so it is not interrupted in the write process. If interrupted for more than 40  $\mu$ s the write will not take place as write bit, `FCTL.WRITE`, will be reset.

When the DMA channel is armed, starting a flash write by setting `FCTL.WRITE` to 1 will trigger the first DMA transfer (DMA and Flash controller handles the reset of the transfer).

Figure 15 shows an example of how a DMA channel is configured and how a DMA transfer is initiated to write a block of data from a location in XDATA to flash memory, assuming the code is executed from RAM (unified CODE).

#### DMA Flash Write from XDATA memory

When performing DMA flash write while executing code from within flash memory, the instruction that triggers the first DMA trigger event `FLASH` (`TRIG[4:0]=10010` DMA in configuration) must be aligned on a 4-byte boundary. Figure 14 shows an example of code that correctly aligns the instruction for triggering DMA (Note that this code is *IAR* specific).

```

; Write flash and generate Flash DMA trigger
; Code is executed from flash memory
;
#include "ioCC2430.h"
    MODULE flashDmaTrigger.s51
    RSEG RCODE (2)
    PUBLIC halFlashDmaTrigger
    FUNCTION halFlashDmaTrigger, 0203H

    halFlashDmaTrigger:
    ORL FCTL, #0x02;
    RET;
    END;

```

Figure 14: Flash write using DMA from flash

Peripherals : Flash Controller

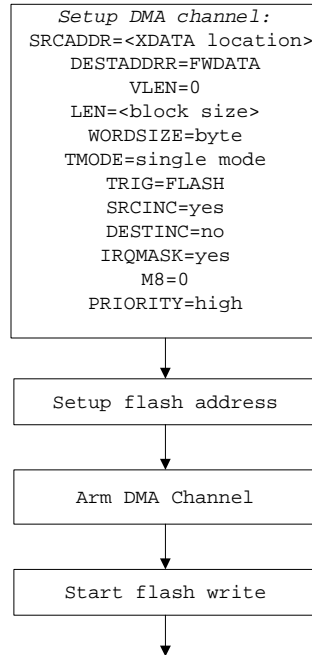

Figure 15: Flash write using DMA

13.3.2.2 CPU Flash Write

The CPU can also write directly to the flash when executing program code from RAM using Unified CODE memory space. The CPU writes data to the Flash Write Data register, FWDATA. The flash memory is written each time four bytes have been written to FWDATA, and FCTL.WRITE bit set to 1. The CPU can poll the FCTL.SWBSY status to determine when the flash is ready for four more bytes to be written to FWDATA. Note that all flash writes needs to be four bytes aligned. Also note that there exist a timeout periode for writing to one flash word, thus writing all four bytes to the FWDATA register has to end within 40 µs after FCTL.SWBSY went low in repeated writes, or

after FCTL.WRITE set for first time write. The FCTL.BUSY=0 flag will indicate if the time out happened or not. If FCTL.BUSY= 0 the write ended and one have to start over again by enabling the FCTL.WRITE bit. The address is set for word to write to, but FWDATA has to be updated again with the 4 bytes that casuse the time out to happen.

**Performing CPU flash write**

The steps required to start a CPU flash write operation are shown in Figure 16 on page 75. Note that code must be run from RAM in unified CODE memory space.

Peripherals : Flash Controller

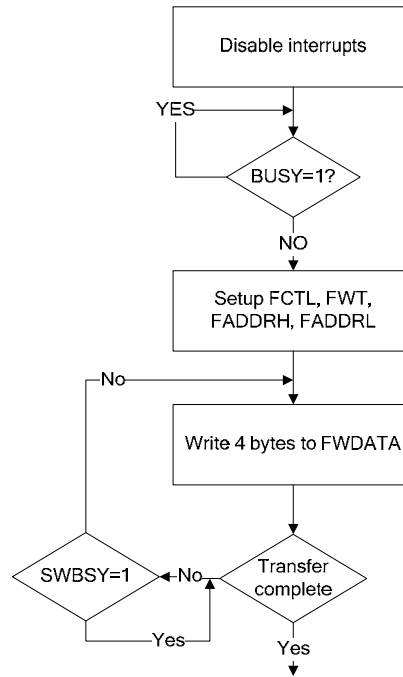

Figure 16: Performing CPU Flash write

13.3.3 Flash Page Erase

After a flash page erase, all bytes in the erased page are set to 1.

A page erase is initiated by setting FCTL.ERASE to 1. The page addressed by FADDRH[6:1] is erased when a page erase is initiated. Note that if a page erase is initiated simultaneously with a page write, i.e. FCTL.WRITE is set to 1, the page erase will be performed before the page write operation. The FCTL.BUSY bit can be polled to see when the page erase has completed.

*Note: If flash page erase operation is performed from within flash memory and the watchdog timer is enabled, a watchdog timer interval must be selected that is longer than 20 ms, the duration of the flash page erase operation, so that the CPU will manage to clear the watchdog timer.*

Performing flash erase from flash memory

The steps required to perform a flash page erase from within flash memory are outlined in Figure 17.

Note that, while executing program code from within flash memory, when a flash erase or write operation is initiated, program execution will resume from the next instruction when the flash controller has completed the operation. The flash erase operation requires that the instruction that starts the erase i.e. writing to FCTL.ERASE is followed by a NOP instruction as shown in the example code. Omitting the NOP instruction after the flash erase operation will lead to undefined behavior.

```

; Erase page in flash memory
; Assumes 32 MHz system clock is used
;
C1: CLR EA ;mask interrupts
MOV A,FCTL ;wait until flash controller is ready
JB ACC.7,C1
MOV FADDRH,#00h ;setup flash address high
MOV FWT,#2Ah ;setup flash timing
MOV FCTL,#01h ;erase page
NOP ;must always execute a NOP after erase
RET ;continues here when flash is ready
  
```

Figure 17: Flash page erase performed from flash memory

### 13.3.4 Flash Write Timing

The Flash Controller contains a timing generator, which controls the timing sequence of flash write and erase operations. The timing generator uses the information set in the Flash Write Timing register, `FWT.FWT[5:0]`, to set the internal timing. `FWT.FWT[5:0]` must be set to a value according to the currently selected CPU clock frequency.

The value set in the `FWT.FWT[5:0]` shall be set according to the CPU clock frequency. The initial value held in `FWT.FWT[5:0]` after a reset is `0x2A` which corresponds to 32 MHz CPU clock frequency.

The `FWT` values for the 16 MHz and 32 MHz CPU clock frequencies are given in Table 39.

**Table 39: Flash timing (FWT) values**

CPU clock frequency (MHz)	FWT
16	0x15
32	0x2A

### 13.3.5 Flash DMA trigger

The Flash DMA trigger is activated when flash data written to the `FWDATA` register has been written to the specified location in the flash memory, thus indicating that the flash controller is ready to accept new data to be written to `FWDATA`. In order to start first transfer one has to set the `FCTL.WRITE` bit to 1. The DMA and the flash controller will then handle all transfer automatically for the defined block of data (`LEN` in DMA configuration). It is further important that the DMA is armed prior to setting the `FCTL.WRITE` bit and that the

trigger source set to `FLASH` (`TRIG[4:0]=10010`) and that the DMA has high priority so the transfer is not interrupted. If interrupted for more than 40  $\mu$ s the write will not complete as write flag is reset (not allowed to access one word for write for more than 40  $\mu$ s thus protection to turn the write off).

### 13.3.6 Flash Controller Registers

The Flash Controller registers are described in this section.

Peripherals : I/O ports

### FCTL (0xAE) – Flash Control

Bit	Name	Reset	R/W	Description
7	BUSY	0	R	Indicates that write or erase is in operation 0 No write or erase operation active 1 Write or erase operation activated
6	SWBSY	0	R	Indicates that current word write is busy; avoid writing to FWDATA register while this is true 0 Ready to accept data 1 Busy
5	-	0	R/W	Not used.
4	CONTRD	0	R/W	Continuous read enable mode 0 Avoid wasting power; turn on read enables to flash only when needed 1 Enable continuous read enables to flash when read is to be done. Reduces internal switching of read enables, but greatly increases power consumption.
3:2		0	R/W	Not used.
1	WRITE	0	R0/W	Write. Start writing word at location given by FADDRH : FADDRL. If ERASE is set to 1, a page erase of the whole page addressed by FADDRH , is performed before the write.
0	ERASE	0	R0/W	Page Erase. Erase page that is given by FADDRH[ 6 : 1 ]

### FWDATA (0xAF) – Flash Write Data

Bit	Name	Reset	R/W	Description
7:0	FWDATA[ 7 : 0 ]	0x00	R/W	Flash write data. Data written to FWDATA is written to flash when FCTL . WRITE is set to 1.

### FADDRH (0xAD) – Flash Address High Byte

Bit	Name	Reset	R/W	Description
7	-	0	R/W	Not used
6:0	FADDRH[ 6 : 0 ]	0x00	R/W	Page address / High byte of flash word address Bits 6:1 will select which page to access.

### FADDRL (0xAC) – Flash Address Low Byte

Bit	Name	Reset	R/W	Description
7:0	FADDRL[ 7 : 0 ]	0x00	R/W	Low byte of flash word address

### FWT (0xAB) – Flash Write Timing

Bit	Name	Reset	R/W	Description
7:6	-	00	R/W	Not used
5:0	FWT[ 5 : 0 ]	0x2A	R/W	Flash Write Timing. Controls flash timing generator.

## 13.4 I/O ports

The **CC2430** has 21 digital input/output pins that can be configured as general purpose digital I/O or as peripheral I/O signals connected to the ADC, Timers or USART

peripherals. The usage of the I/O ports is fully configurable from user software through a set of configuration registers.

The I/O ports have the following key features:

Peripherals : I/O ports

- 21 digital input/output pins
- General purpose I/O or peripheral I/O
- Pull-up or pull-down capability on inputs
- External interrupt capability

The external interrupt capability is available on all 21 I/O pins. Thus external devices may generate interrupts if required. The external interrupt feature can also be used to wake up from sleep modes.

13.4.1 Unused I/O pins

Unused I/O pins should have a defined level and not be left floating. One way to do this is to leave the pin unconnected and configure the pin as a general purpose I/O input with pull-up resistor. This is also the state of all pins after reset (note that only P2[2] has pull-up during

reset). Alternatively the pin can be configured as a general purpose I/O output. In both cases the pin should not be connected directly to VDD or GND in order to avoid excessive power consumption.

13.4.2 Low I/O Supply Voltage

In applications where the digital I/O power supply voltage pin DVDD is below 2.6 V, the register bit PICTL.PADSC should be set to 1

in order to obtain output DC characteristics specified in section 7.16.

13.4.3 General Purpose I/O

When used as general purpose I/O, the pins are organized as three 8-bit ports, ports 0-2, denoted P0, P1 and P2. P0 and P1 are complete 8-bit wide ports while P2 has only five usable bits. All ports are both bit- and byte addressable through the SFR registers P0, P1 and P2. Each port pin can individually be set to operate as a general purpose I/O or as a peripheral I/O.

When reading the port registers P0, P1 and P2, the logic values on the input pins are returned regardless of the pin configuration. This does not apply during the execution of read-modify-write instructions. The read-modify-write instructions are: ANL, ORL, XRL, JBC, CPL, INC, DEC, DJNZ and MOV, CLR or SETB. Operating on a port registers the following is true: When the destination is an individual bit in a port register P0, P1 or P2 the value of the register, not the value on the pin, is read, modified, and written back to the port register.

The output drive strength is 4 mA on all outputs, except for the two high-drive outputs, P1\_0 and P1\_1, which each have 20 mA output drive strength.

When used as an input, the general purpose I/O port pins can be configured to have a pull-up, pull-down or tri-state mode of operation. By default, after a reset, inputs are configured as inputs with pull-up. To deselect the pull-up or pull-down function on an input the appropriate bit within the P<sub>x</sub>INP must be set to 1. The I/O port pins P1\_0 and P1\_1 do not have pull-up/pull-down capability.

The registers P<sub>x</sub>SEL where x is the port number 0-2 are used to configure each pin in a port as either a general purpose I/O pin or as a peripheral I/O signal. By default, after a reset, all digital input/output pins are configured as general-purpose input pins.

In power modes PM2 and PM3 the I/O pins retain the I/O mode and output value (if applicable) that was set when PM2/3 was entered.

To change the direction of a port pin, at any time, the registers P<sub>x</sub>DIR are used to set each port pin to be either an input or an output. Thus by setting the appropriate bit within P<sub>x</sub>DIR, to 1 the corresponding pin becomes an output.

13.4.4 General Purpose I/O Interrupts

General purpose I/O pins configured as inputs can be used to generate interrupts. The interrupts can be configured to trigger on either a rising or falling edge of the external signal. Each of the P0, P1 and P2 ports have separate interrupt enable bits common for all bits within the port located in the IEN1-2 registers as follows:

- IEN1.P0IE : P0 interrupt enable
- IEN2.P1IE : P1 interrupt enable
- IEN2.P2IE : P2 interrupt enable

In addition to these common interrupt enables, the bits within each port have interrupt enables located in I/O port SFR registers. Each bit within P1 has an individual interrupt enable. In P0 the low-order nibble and the high-order

Peripherals : I/O ports

nibble have their individual interrupt enables. For the P2\_0 – P2\_4 inputs there is a common interrupt enable.

When an interrupt condition occurs on one of the general purpose I/O pins, the corresponding interrupt status flag in the P0-P2 interrupt flag registers, P0IFG, P1IFG or P2IFG will be set to 1. The interrupt status flag is set regardless of whether the pin has its interrupt enable set. When an interrupt is serviced the interrupt status flag is cleared by writing a 0 to that flag, and this flag must be

cleared prior to clearing the CPU port interrupt flag (PxIF).

The I/O SFR registers used for interrupts are described in section 13.4.9 on page 82. The registers are summarized below:

- P1IEN : P1 interrupt enables
- PICTL : P0/P2 interrupt enables and P0-2 edge configuration
- P0IFG : P0 interrupt flags
- P1IFG : P1 interrupt flags
- P2IFG : P2 interrupt flags

13.4.5 General Purpose I/O DMA

When used as general purpose I/O pins, the P0 and P1 ports are each associated with one DMA trigger. These DMA triggers are IOC\_0 for P0 and IOC\_1 for P1 as shown in Table 41 on page 94.

The IOC\_0 or IOC\_1 DMA trigger is activated when an input transition occurs on one of the P0 or P1 pins respectively. Note that input

transitions on pins configured as general purpose I/O inputs only will produce the DMA trigger.

Note that port registers P0 and P1 are mapped to XDATA memory space (see Table 24 on page 35). Therefore these registers are reachable for DMA transfers. Port register P2 is not reachable for DMA transfers.

13.4.6 Peripheral I/O

This section describes how the digital I/O pins are configured as peripheral I/Os. For each peripheral unit that can interface with an external system through the digital input/output pins, a description of how peripheral I/Os are configured is given in the following sub-sections.

In general, setting the appropriate PxSEL bits to 1 is required to select peripheral I/O function on a digital I/O pin.

Note that peripheral units have two alternative locations for their I/O pins, refer to Table 40. Also note that as a general rule only two peripherals can be used per IO Port at a time. Priority can be set between these if conflicting settings regarding IO mapping is present. Priority among unlisted peripheral units is undefined and should not be used (P2SEL.PRIxP1 and P2DIR.PRIPO bits). All combinations not causing conflicts can be combined.

Table 40: Peripheral I/O Pin Mapping

Periphery / Function	P0								P1								P2					
	7	6	5	4	3	2	1	0	7	6	5	4	3	2	1	0	4	3	2	1	0	
ADC	A7	A6	A5	A4	A3	A2	A1	A0													T	
USART0 SPI Alt. 2			C	SS	M0	MI					M0	MI	C	SS								
USART0 UART Alt. 2			RT	CT	TX	RX					TX	RX	RT	CT								
USART1 SPI Alt. 2			MI	M0	C	SS			MI	M0	C	SS										
USART1 UART Alt. 2			RX	TX	RT	CT			RX	TX	RT	CT										
TIMER1 Alt. 2				2	1	0									0	1	2					
TIMER3 Alt. 2									1	0			1	0								
TIMER4 Alt. 2															1	0		1			0	
32.768 kHz XOSC																	Q2	Q1				
DEBUG																			D C	D D		

13.4.6.1 Timer 1

PERCFG.T1CFG selects whether to use alternative 1 or alternative 2 locations.

In Table 40, the Timer 1 signals are shown as the following:

- 0 : Channel 0 capture/compare pin
- 1 : Channel 1 capture/compare pin
- 2 : Channel 2 capture/compare pin

P2DIR.PRI0P0 selects the order of precedence when assigning several

13.4.6.2 Timer 3

PERCFG.T3CFG selects whether to use alternative 1 or alternative 2 locations.

In Table 40, the Timer 3 signals are shown as the following:

13.4.6.3 Timer 4

PERCFG.T4CFG selects whether to use alternative 1 or alternative 2 locations.

In Table 40, the Timer 4 signals are shown as the following:

peripherals to port 0. When set to 10 or 11 the timer 1 channels have precedence.

P2SEL.PRI1P1 and P2SEL.PRI0P1 select the order of precedence when assigning several peripherals to port 1. The timer 1 channels have precedence when the former is set low and the latter is set high.

- 0 : Channel 0 compare pin
- 1 : Channel 1 compare pin

P2SEL.PRI2P1 selects the order of precedence when assigning several peripherals to port 1. The timer 3 channels have precedence when the bit is set.

- 0 : Channel 0 compare pin
- 1 : Channel 1 compare pin

P2SEL.PRI1P1 selects the order of precedence when assigning several peripherals to port 1. The timer 4 channels have precedence when the bit is set.

#### 13.4.6.4 USART0

The SFR register bit `PERCFG.U0CFG` selects whether to use alternative 1 or alternative 2 locations.

In Table 40, the USART0 signals are shown as follows:

UART:

- RX : RXDATA
- TX : TXDATA
- RT : RTS
- CT : CTS

SPI:

- MI : MISO
- MO : MOSI
- C : SCK
- SS : SSN

#### 13.4.6.5 USART1

The SFR register bit `PERCFG.U1CFG` selects whether to use alternative 1 or alternative 2 locations.

In Table 40, the USART1 signals are shown as follows:

UART:

- RX : RXDATA
- TX : TXDATA
- RT : RTS
- CT : CTS

SPI:

- MI : MISO
- MO : MOSI
- C : SCK
- SS : SSN

#### 13.4.6.6 ADC

When using the ADC, Port 0 pins must be configured as ADC inputs. Up to eight ADC inputs can be used. To configure a Port 0 pin to be used as an ADC input the corresponding bit in the `ADCCFG` register must be set to 1. The default values in this register select the Port 0 pins as non-ADC input i.e. digital input/outputs.

The settings in the `ADCCFG` register override the settings in `P0SEL`.

#### 13.4.7 Debug interface

Ports P2\_1 and P2\_2 are used for debug data and clock signals, respectively. These are shown as DD (debug data) and DC (debug clock) in Table 40. When the debug interface is in use, `P2DIR` should select these pins as

`P2DIR.PRI0` selects the order of precedence when assigning several peripherals to port 0. When set to 00, USART0 has precedence. Note that if UART mode is selected and hardware flow control is disabled, USART1 or timer 1 will have precedence to use ports P0\_4 and P0\_5.

`P2SEL.PRI3P1` and `P2SEL.PRI0P1` select the order of precedence when assigning several peripherals to port 1. USART0 has precedence when both are set to 0. Note that if UART mode is selected and hardware flow control is disabled, timer 1 or timer 3 will have precedence to use ports P1\_2 and P1\_3.

`P2DIR.PRI0` selects the order of precedence when assigning several peripherals to port 0. When set to 01, USART1 has precedence. Note that if UART mode is selected and hardware flow control is disabled, USART0 or timer 1 will have precedence to use ports P0\_2 and P0\_3.

`P2SEL.PRI3P1` and `P2SEL.PRI2P1` select the order of precedence when assigning several peripherals to port 1. USART1 has precedence when the former is set to 1 and the latter is set to 0. Note that if UART mode is selected and hardware flow control is disabled, USART0 or timer 3 will have precedence to use ports P2\_4 and P2\_5.

The ADC can be configured to use the general-purpose I/O pin P2\_0 as an external trigger to start conversions. P2\_0 must be configured as a general-purpose I/O in input mode, when being used for ADC external trigger.

Refer to section 13.9 on page 126 for a detailed description of use of the ADC.

inputs. The state of `P2SEL` is overridden by the debug interface. Also, the direction is overridden when the chip changes the direction to supply the external host with data.

#### 13.4.8 32.768 kHz XOSC input

Ports P2\_3 and P2\_4 are used to connect an external 32.768 kHz crystal. These port pins will be used by the 32.768 kHz crystal oscillator when `CLKCON.OSC32K` is low,

regardless of register settings. The port pins will be set in analog mode when `CLKCON.OSC32K` is low.

#### 13.4.9 Radio Test Output Signals

For debug purposes and to some degree CC2420 pin compability, the `RFSTATUS.SFD`, `RFSTATUS.FIFO`, `RFSTATUS.FIFOP` and `RFSTATUS.CCA` bits can be output onto P1.7 – P1.4 I/O pins to monitor the status of these signals. These test output signals are selected by the `IOCFG0`, `IOCFG1` and `IOCFG2` registers.

- P1.4 – FIFO
- P1.5 – FIFOP
- P1.6 – SFD
- P1.7 – CCA

Configuring this mode has precedence over other settings in the IOC, and these pins will be assigned the above signals and forced to be outputs.

The debug signals are output to the following I/O pins:

#### 13.4.10 I/O registers

The registers for the I/O ports are described in this section. The registers are:

- P0 Port 0
- P1 Port 1
- P2 Port 2
- PERCFG Peripheral control register
- ADCCFG ADC input configuration register
- P0SEL Port 0 function select register
- P1SEL Port 1 function select register
- P2SEL Port 2 function select register
- P0DIR Port 0 direction register
- P1DIR Port 1 direction register
- P2DIR Port 2 direction register
- P0INP Port 0 input mode register
- P1INP Port 1 input mode register
- P2INP Port 2 input mode register
- P0IFG Port 0 interrupt status flag register
- P1IFG Port 1 interrupt status flag register
- P2IFG Port 2 interrupt status flag register
- PICTL Interrupt mask and edge register
- P1IEN Port 1 interrupt mask register

#### P0 (0x80) – Port 0

Bit	Name	Reset	R/W	Description
7:0	P0[7:0]	0xFF	R/W	Port 0. General purpose I/O port. Bit-addressable.

#### P1 (0x90) – Port 1

Bit	Name	Reset	R/W	Description
7:0	P1[7:0]	0xFF	R/W	Port 1. General purpose I/O port. Bit-addressable.

Peripherals : I/O ports

### P2 (0xA0) – Port 2

Bit	Name	Reset	R/W	Description
7:5	–	000	R0	Not used
4:0	P2[4:0]	0x1F	R/W	Port 2. General purpose I/O port. Bit-addressable.

### PERCFG (0xF1) – Peripheral Control

Bit	Name	Reset	R/W	Description
7	–	0	R0	Not used
6	T1CFG	0	R/W	Timer 1 I/O location 0 Alternative 1 location 1 Alternative 2 location
5	T3CFG	0	R/W	Timer 3 I/O location 0 Alternative 1 location 1 Alternative 2 location
4	T4CFG	0	R/W	Timer 4 I/O location 0 Alternative 1 location 1 Alternative 2 location
3:2	–	00	R0	Not used
1	U1CFG	0	R/W	USART1 I/O location 0 Alternative 1 location 1 Alternative 2 location
0	U0CFG	0	R/W	USART0 I/O location 0 Alternative 1 location 1 Alternative 2 location

### ADCCFG (0xF2) – ADC Input Configuration

Bit	Name	Reset	R/W	Description
7:0	ADCCFG[7:0]	0x00	R/W	ADC input configuration. ADCCFG[7:0] select P0_7 - P0_0 as ADC inputs AIN7 – AIN0 0 ADC input disabled 1 ADC input enabled

### P0SEL (0xF3) – Port 0 Function Select

Bit	Name	Reset	R/W	Description
7:0	SELP0_[7:0]	0x00	R/W	P0_7 to P0_0 function select 0 General purpose I/O 1 Peripheral function

### P1SEL (0xF4) – Port 1 Function Select

Bit	Name	Reset	R/W	Description
7:0	SELP1_[7:0]	0x00	R/W	P1_7 to P1_0 function select 0 General purpose I/O 1 Peripheral function

Peripherals : I/O ports

### P2SEL (0xF5) – Port 2 Function Select

Bit	Name	Reset	R/W	Description
7	–	0	R0	Not used
6	PRI3P1	0	R/W	Port 1 peripheral priority control. These bits shall determine which module has priority in the case when modules are assigned to the same pins. 0 USART0 has priority 1 USART1 has priority
5	PRI2P1	0	R/W	Port 1 peripheral priority control. These bits shall determine the order of priority in the case when PERCFG assigns USART1 and timer 3 to the same pins. 0 USART1 has priority 1 Timer 3 has priority
4	PRI1P1	0	R/W	Port 1 peripheral priority control. These bits shall determine the order of priority in the case when PERCFG assigns timer 1 and timer 4 to the same pins. 0 Timer 1 has priority 1 Timer 4 has priority
3	PRI0P1	0	R/W	Port 1 peripheral priority control. These bits shall determine the order of priority in the case when PERCFG assigns USART0 and timer 1 to the same pins. 0 USART0 has priority 1 Timer 1 has priority
2	SELP2_4	0	R/W	P2_4 function select 0 General purpose I/O 1 Peripheral function
1	SELP2_3	0	R/W	P2_3 function select 0 General purpose I/O 1 Peripheral function
0	SELP2_0	0	R/W	P2_0 function select 0 General purpose I/O 1 Peripheral function

### P0DIR (0xFD) – Port 0 Direction

Bit	Name	Reset	R/W	Description
7:0	DIRP0_[7:0]	0x00	R/W	P0_7 to P0_0 I/O direction 0 Input 1 Output

### P1DIR (0xFE) – Port 1 Direction

Bit	Name	Reset	R/W	Description
7:0	DIRP1_[7:0]	0x00	R/W	P1_7 to P1_0 I/O direction 0 Input 1 Output

## Peripherals : I/O ports

**P2DIR (0xFF) – Port 2 Direction**

Bit	Name	Reset	R/W	Description
7:6	PRIP0[1:0]	00	R/W	Port 0 peripheral priority control. These bits shall determine the order of priority in the case when PERCFG assigns several peripherals to the same pins 00 USART0 has priority over USART1 01 USART1 has priority OVER Timer1 10 Timer 1 channels 0 and 1has priority over USART1 11 Timer 1 channel 2 has priority over USART0
5	–	0	R0	Not used
4:0	DIRP2_[4:0]	00000	R/W	P2_4 to P2_0 I/O direction 0 Input 1 Output

**P0INP (0x8F) – Port 0 Input Mode**

Bit	Name	Reset	R/W	Description
7:0	MDP0_[7:0]	0x00	R/W	P0_7 to P0_0 I/O input mode 0 Pull-up / pull-down (see P2INP (0xF7) – Port 2 Input Mode) 1 Tristate

**P1INP (0xF6) – Port 1 Input Mode**

Bit	Name	Reset	R/W	Description
7:2	MDP1_[7:2]	0x00	R/W	P1_7 to P1_2 I/O input mode 0 Pull-up / pull-down (see P2INP (0xF7) – Port 2 Input Mode) 1 Tristate
1:0	–	00	R0	Not used

**P2INP (0xF7) – Port 2 Input Mode**

Bit	Name	Reset	R/W	Description
7	PDUP2	0	R/W	Port 2 pull-up/down select. Selects function for all Port 2 pins configured as pull-up/pull-down inputs. 0 Pull-up 1 Pull-down
6	PDUP1	0	R/W	Port 1 pull-up/down select. Selects function for all Port 1 pins configured as pull-up/pull-down inputs. 0 Pull-up 1 Pull-down
5	PDUP0	0	R/W	Port 0 pull-up/down select. Selects function for all Port 0 pins configured as pull-up/pull-down inputs. 0 Pull-up 1 Pull-down
4:0	MDP2_[4:0]	00000	R/W	P2_4 to P2_0 I/O input mode 0 Pull-up / pull-down 1 Tristate

## Peripherals : I/O ports

**P0IFG (0x89) – Port 0 Interrupt Status Flag**

Bit	Name	Reset	R/W	Description
7:0	P0IF[7:0]	0x00	R/W0	Port 0, inputs 7 to 0 interrupt status flags. When an input port pin has an interrupt request pending, the corresponding flag bit will be set.

**P1IFG (0x8A) – Port 1 Interrupt Status Flag**

Bit	Name	Reset	R/W	Description
7:0	P1IF[7:0]	0x00	R/W0	Port 1, inputs 7 to 0 interrupt status flags. When an input port pin has an interrupt request pending, the corresponding flag bit will be set.

**P2IFG (0x8B) – Port 2 Interrupt Status Flag**

Bit	Name	Reset	R/W	Description
7:5	–	000	R0	Not used.
4:0	P2IF[4:0]	0x00	R/W0	Port 2, inputs 4 to 0 interrupt status flags. When an input port pin has an interrupt request pending, the corresponding flag bit will be set.

Peripherals : I/O ports

### PICTL (0x8C) – Port Interrupt Control

Bit	Name	Reset	R/W	Description
7	–	0	R0	Not used
6	PADSC	0	R/W	Drive strength control for I/O pins in output mode. Selects output drive capability to account for low I/O supply voltage on pin DVDD (this to ensure same drive strength at lower voltages as is on higher). 0 Minimum drive capability. DVDD equal or greater than 2.6V 1 Maximum drive capability. DVDD less than 2.6V
5	P2IEN	0	R/W	Port 2, inputs 4 to 0 interrupt enable. This bit enables interrupt requests for the port 2 inputs 4 to 0. 0 Interrupts are disabled 1 Interrupts are enabled
4	P0IENH	0	R/W	Port 0, inputs 7 to 4 interrupt enable. This bit enables interrupt requests for the port 0 inputs 7 to 4. 0 Interrupts are disabled 1 Interrupts are enabled
3	P0IENL	0	R/W	Port 0, inputs 3 to 0 interrupt enable. This bit enables interrupt requests for the port 0 inputs 3 to 0. 0 Interrupts are disabled 1 Interrupts are enabled
2	P2ICON	0	R/W	Port 2, inputs 4 to 0 interrupt configuration. This bit selects the interrupt request condition for all port 2 inputs 0 Rising edge on input gives interrupt 1 Falling edge on input gives interrupt
1	P1ICON	0	R/W	Port 1, inputs 7 to 0 interrupt configuration. This bit selects the interrupt request condition for all port 1 inputs 0 Rising edge on input gives interrupt 1 Falling edge on input gives interrupt
0	P0ICON	0	R/W	Port 0, inputs 7 to 0 interrupt configuration. This bit selects the interrupt request condition for all port 0 inputs 0 Rising edge on input gives interrupt 1 Falling edge on input gives interrupt

### P1IEN (0x8D) – Port 1 Interrupt Mask

Bit	Name	Reset	R/W	Description
7:0	P1_[7:0]IEN	0x00	R/W	Port P1_7 to P1_0 interrupt enable 0 Interrupts are disabled 1 Interrupts are enabled

## 13.5 DMA Controller

The **CC2430** includes a direct memory access (DMA) controller, which can be used to relieve the 8051 CPU core of handling data movement operations thus achieving high overall performance with good power efficiency. The DMA controller can move data from a peripheral unit such as ADC or RF transceiver to memory with minimum CPU intervention.

The DMA controller coordinates all DMA transfers, ensuring that DMA requests are prioritized appropriately relative to each other and CPU memory access. The DMA controller contains a number of programmable DMA channels for memory-memory data movement.

The DMA controller controls data transfers over the entire address range in XDATA memory space. Since most of the SFR registers are mapped into the DMA memory space, these flexible DMA channels can be used to unburden the CPU in innovative ways, e.g. feed a USART with data from memory or

### 13.5.1 DMA Operation

There are five DMA channels available in the DMA controller numbered channel 0 to channel 4. Each DMA channel can move data from one place within the DMA memory space to another i.e. between XDATA locations.

In order to use a DMA channel it must first be configured as described in sections 13.5.2 and 13.5.3. Figure 18 shows the DMA state diagram.

Once a DMA channel has been configured it must be armed before any transfers are allowed to be initiated. A DMA channel is armed by setting the appropriate bit in the DMA Channel Arm register `DMAARM`.

When a DMA channel is armed a transfer will begin when the configured DMA trigger event occurs. Note that the time to arm one channel (i.e. get configuration data) takes 9 system clocks, thus if `DMAARM` bit set and a trigger appears within the time it takes to configure

periodically transfer samples between ADC and memory, etc. Use of the DMA can also reduce system power consumption by keeping the CPU in a low-power mode without having to wake up to move data to or from a peripheral unit (see section 13.1.1.1 for CPU low power mode). Note that section 11.2.3 describes which SFR registers that are not mapped into XDATA memory space.

The main features of the DMA controller are as follows:

- Five independent DMA channels
- Three configurable levels of DMA channel priority
- 31 configurable transfer trigger events
- Independent control of source and destination address
- Single, block and repeated transfer modes
- Supports length field in transfer data setting variable transfer length
- Can operate in either word-size or byte-size mode

the channel the trigger will be lost. If more than one DMA channels are armed simultaneously, the time for all channels to be configured will be longer (sequential read from memory). If all 5 are armed it will take 45 system clocks and channel 1 will first be ready, then channel 2 and lastly channel 0 (all within the last 8 system clocks). There are 31 possible DMA trigger events, e.g. UART transfer, Timer overflow etc. The trigger event to be used by a DMA channel is set by the DMA channel configuration thus no knowledge of this is available until after configuration has been read. The DMA trigger events are listed in Table 41.

In addition to starting a DMA transfer through the DMA trigger events, the user software may force a DMA transfer to begin by setting the corresponding `DMAREQ` bit.

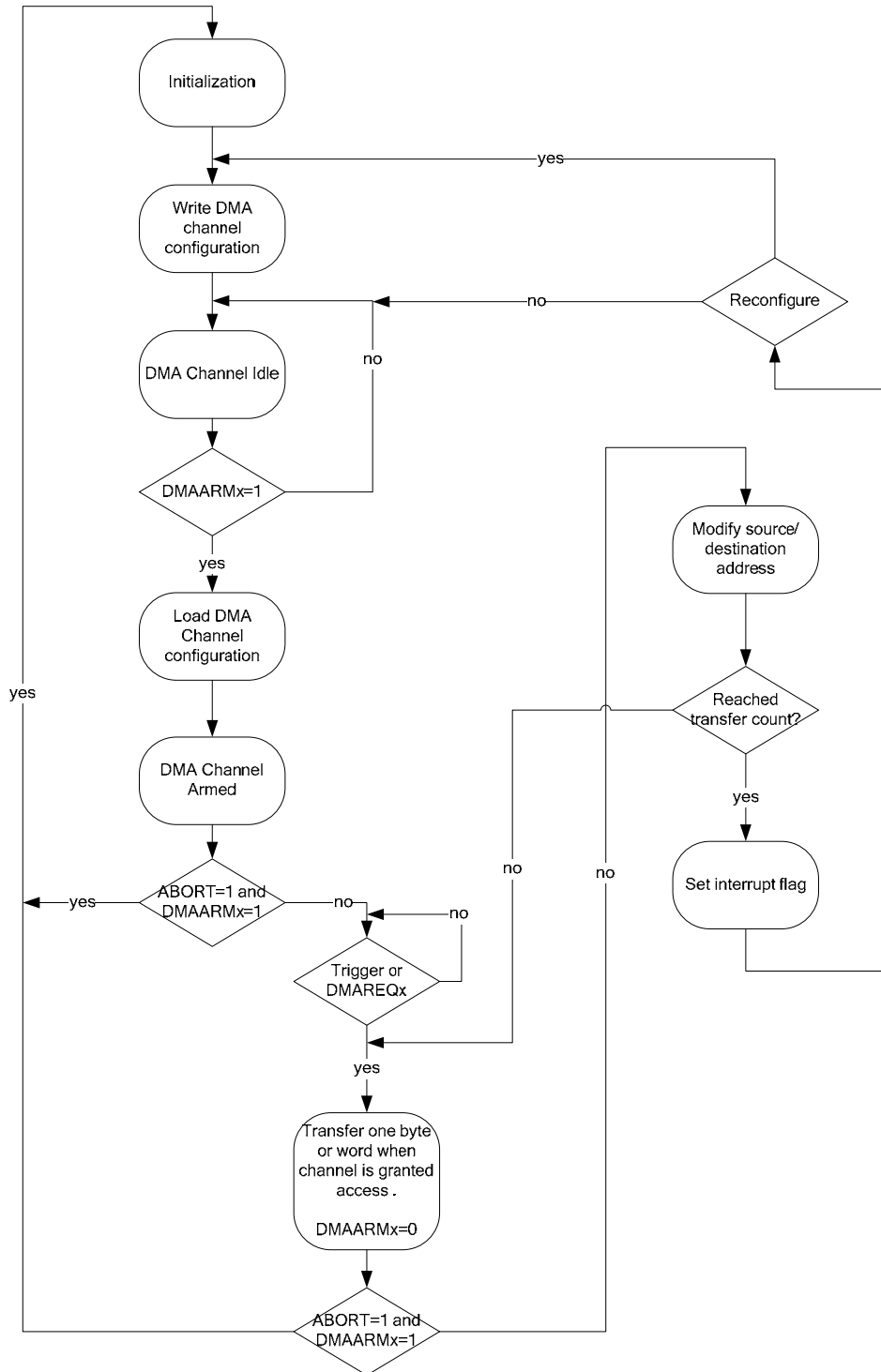

Figure 18: DMA Operation

13.5.2 DMA Configuration Parameters

Setup and control of the DMA operation is performed by the user software. This section describes the parameters which must be configured before a DMA channel can be used. Section 13.5.3 on page 92 describes how the parameters are set up in software and passed to the DMA controller.

The behavior of each of the five DMA channels is configured with the following parameters:

**Source address:** The first address from which the DMA channel should read data.

**Destination address:** The first address to which the DMA channel should write the data

read from the source address. The user must ensure that the destination is writable.

**Transfer count:** The number of transfers to perform before rearming or disarming the DMA channel and alerting the CPU with an interrupt request. The length can be defined in the configuration or it can be defined as described next as VLEN setting.

**VLEN setting:** The DMA channel is capable of variable length transfers using the first byte or word to set the transfer length. When doing this, various options regarding how to count number of bytes to transfer are available.

**Priority:** The priority of the DMA transfers for the DMA channel in respect to the CPU and other DMA channels and access ports.

**Trigger event:** All DMA transfers are initiated by so-called DMA trigger events. This trigger either starts a DMA block transfer or a single DMA transfer. In addition to the configured trigger, a DMA channel can always be triggered by setting its designated `DMAREQ.DMAREQx` flag. The DMA trigger sources are described in Table 41 on page 94.

#### 13.5.2.1 Source Address

The address in XDATA memory where the DMA channel shall start to read data.

#### 13.5.2.2 Destination Address

The first address to which the DMA channel should write the data read from the source

#### 13.5.2.3 Transfer Count

The number of bytes/words needed to be transferred for the DMA transfer to be complete. When the transfer count is reached, the DMA controller rearms or disarms the DMA

#### 13.5.2.4 VLEN Setting

The DMA channel is capable of using the first byte or word (for word, bits 12:0 are used) in source data as the transfer length. This allows variable length transfers. When using variable length transfer, various options regarding how to count number of bytes to transfer is given. In any case, the transfer count (LEN) setting is used as maximum transfer count. If the transfer length specified by the first byte or word is greater than LEN, then LEN bytes/words will be transferred. When using variable length transfers, then LEN should be set to the largest allowed transfer length plus one.

Note that the M8 bit (see page 92) is only used when byte size transfers are chosen.

**Source and Destination Increment:** The source and destination addresses can be controlled to increment or decrement or not change.

**Transfer mode:** The transfer mode determines whether the transfer should be a single transfer or a block transfer, or repeated versions of these.

**Byte or word transfers:** Determines whether each DMA transfer should be 8-bit (byte) or 16-bit (word).

**Interrupt Mask:** An interrupt request is generated upon completion of the DMA transfer. The interrupt mask bit controls if the interrupt generation is enabled or disabled.

**M8:** Decide whether to use seven or eight bits of length byte for transfer length. This is only applicable when doing byte transfers.

A detailed description of all configuration parameters are given in the sections 13.5.2.1 to 13.5.2.11.

address. The user must ensure that the destination is writable.

channel and alerts the CPU with an interrupt request. The transfer count can be defined in the configuration or it can be defined as a variable length described in the next section.

Options which can be set with VLEN are the following:

1. Transfer number of bytes/words commanded by first byte/word + 1 (transfers the length byte/word, and then as many bytes/words as dictated by length byte/word)
2. Transfer number of bytes/words commanded by first byte/word
3. Transfer number of bytes/words commanded by first byte/word + 2 (transfers the length byte/word, and then as many bytes/words as dictated by length byte/word + 1)

4. Transfer number of bytes/words commanded by first byte/word + 3 (transfers the length byte/word, and then as many bytes/words as dictated by length byte/word + 2)

Figure 19 shows the VLEN options.

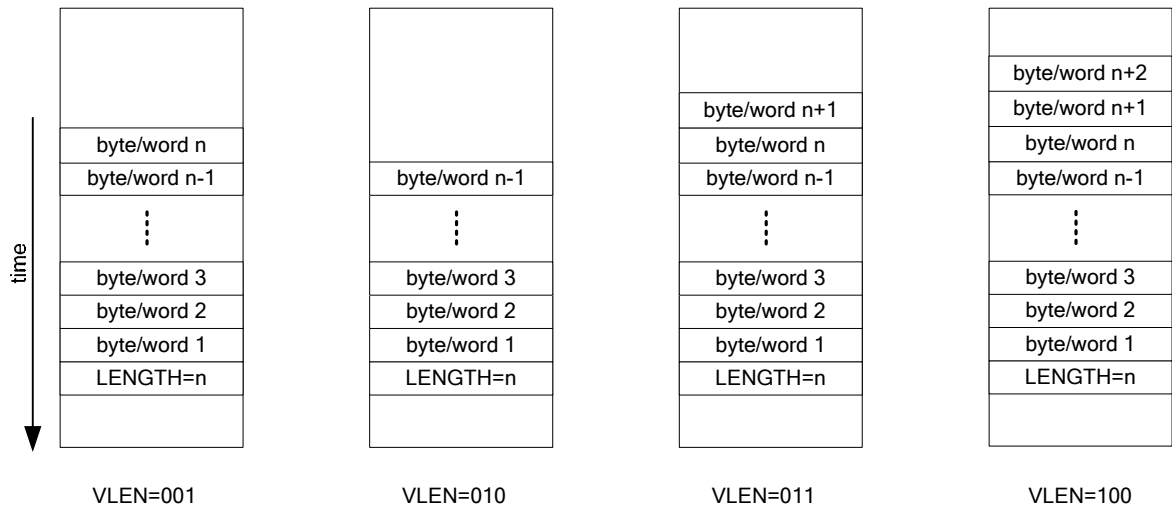

Figure 19: Variable Length (VLEN) Transfer Options

13.5.2.5 Trigger Event

Each DMA channel can be set up to sense on a single trigger. This field determines which trigger the DMA channel shall sense.

13.5.2.6 Source and Destination Increment

When the DMA channel is armed or rearmed the source and destination addresses are transferred to internal address pointers. The possibilities for address increment are :

- *Increment by zero.* The address pointer shall remain fixed after each transfer.
- *Increment by one.* The address pointer shall increment one count after each transfer.

- *Increment by two.* The address pointer shall increment two counts after each transfer.
- *Decrement by one.* The address pointer shall decrement one count after each transfer.

13.5.2.7 DMA Transfer Mode

The transfer mode determines how the DMA channel behaves when it starts transferring data. There are four transfer modes described below:

**Single:** On a trigger a single DMA transfer occurs and the DMA channel awaits the next trigger. After the number of transfers specified by the transfer count, are completed, the CPU is notified and the DMA channel is disarmed.

**Block:** On a trigger the number of DMA transfers specified by the transfer count is performed as quickly as possible, after which

the CPU is notified and the DMA channel is disarmed.

**Repeated single:** On a trigger a single DMA transfer occurs and the DMA channel awaits the next trigger. After the number of transfers specified by the transfer count are completed, the CPU is notified and the DMA channel is rearmed.

**Repeated block:** On a trigger the number of DMA transfers specified by the transfer count is performed as quickly as possible, after which the CPU is notified and the DMA channel is rearmed.

### 13.5.2.8 DMA Priority

A DMA priority is configurable for each DMA channel. The DMA priority is used to determine the winner in the case of multiple simultaneous internal memory requests, and whether the DMA memory access should have priority or not over a simultaneous CPU memory access. In case of an internal tie, a round-robin scheme is used to ensure access for all. There are three levels of DMA priority:

**High:** Highest internal priority. DMA access will always prevail over CPU access.

**Normal:** Second highest internal priority. This guarantees that DMA access prevails over CPU on at least every second try.

**Low:** Lowest internal priority. DMA access will always defer to a CPU access.

### 13.5.2.9 Byte or Word transfers

Determines whether 8-bit (byte) or 16-bit (word) are done.

### 13.5.2.10 Interrupt mask

Upon completing a DMA transfer, the channel can generate an interrupt to the processor. This bit will mask the interrupt.

### 13.5.2.11 Mode 8 setting

This field determines whether to use 7 or 8 bits of length byte for transfer length. Only applicable when doing byte transfers.

## 13.5.3 DMA Configuration Setup

The DMA channel parameters such as address mode, transfer mode and priority described in the previous section have to be configured before a DMA channel can be armed and activated. The parameters are not configured directly through SFR registers, but instead they are written in a special DMA configuration data structure in memory. Each DMA channel in use requires its own DMA configuration data structure. The DMA configuration data structure consists of eight bytes and is described in section 13.5.6 on page 93. A DMA configuration data structure may reside at any location decided upon by the user software, and the address location is passed to the DMA controller through a set of SFRs `DMAxCFGH:DMAxCFGL`. Once a channel has been armed, the DMA controller will read the configuration data structure for that channel, given by the address in `DMAxCFGH:DMAxCFGL`.

It is important to note that the method for specifying the start address for the DMA configuration data structure differs between DMA channel 0 and DMA channels 1-4 as follows:

`DMA0CFGH:DMA0CFGL` gives the start address for DMA channel 0 configuration data structure.

`DMA1CFGH:DMA1CFGL` gives the start address for DMA channel 1 configuration data structure followed by channel 2-4 configuration data structures.

Thus the DMA controller expects the DMA configuration data structures for DMA channels 1-4 to lie in a contiguous area in memory starting at the address held in `DMA1CFGH:DMA1CFGL` and consisting of 32 bytes.

## 13.5.4 Stopping DMA Transfers

Ongoing DMA transfer or armed DMA channels will be aborted using the `DMAARM` register to disarm the DMA channel.

One or more DMA channels are aborted by writing a 1 to `DMAARM.ABORT` register bit, and at the same time select which DMA

channels to abort by setting the corresponding, `DMAARM.DMAARMx` bits to 1. When setting `DMAARM.ABORT` to 1, the `DMAARM.DMAARMx` bits for non-aborted channels must be written as 0.

### 13.5.5 DMA Interrupts

Each DMA channel can be configured to generate an interrupt to the CPU upon completing a DMA transfer. This is accomplished with the IRQMASK bit in the channel configuration. The corresponding interrupt flag in the DMAIRQ SFR register will be set when the interrupt is generated.

Regardless of the IRQMASK bit in the channel configuration, the interrupt flag will be set upon DMA channel complete. Thus software should always check (and clear) this register when rearming a channel with a changed IRQMASK setting. Failure to do so could generate an interrupt based on the stored interrupt flag.

### 13.5.6 DMA Configuration Data Structure

For each DMA channel, the DMA configuration data structure consists of eight bytes. The

configuration data structure is described in Table 42.

### 13.5.7 DMA memory access

The DMA data transfer is affected by endian convention. This as the memory system use Big-Endian in XDATA memory, while Little-

Endian is used in SFR memory. This must be accounted for in compilers.

Peripherals : DMA Controller

**Table 41: DMA Trigger Sources**

DMA Trigger number	DMA Trigger name	Functional unit	Description
0	NONE	DMA	No trigger, setting DMAREQ . DMAREQx bit starts transfer
1	PREV	DMA	DMA channel is triggered by completion of previous channel
2	T1_CH0	Timer 1	Timer 1, compare, channel 0
3	T1_CH1	Timer 1	Timer 1, compare, channel 1
4	T1_CH2	Timer 1	Timer 1, compare, channel 2
5	T2_COMP	Timer 2	Timer 2, compare
6	T2_OVFL	Timer 2	Timer 2, overflow
7	T3_CH0	Timer 3	Timer 3, compare, channel 0
8	T3_CH1	Timer 3	Timer 3, compare, channel 1
9	T4_CH0	Timer 4	Timer 4, compare, channel 0
10	T4_CH1	Timer 4	Timer 4, compare, channel 1
11	ST	Sleep Timer	Sleep Timer compare
12	IOC_0	IO Controller	Port 0 I/O pin input transition <sup>9</sup>
13	IOC_1	IO Controller	Port 1 I/O pin input transition <sup>9</sup>
14	URX0	USART0	USART0 RX complete
15	UTX0	USART0	USART0 TX complete
16	URX1	USART1	USART1 RX complete
17	UTX1	USART1	USART1 TX complete
18	FLASH	Flash controller	Flash data write complete
19	RADIO	Radio	RF packet byte received/transmit
20	ADC_CHALL	ADC	ADC end of a conversion in a sequence, sample ready
21	ADC_CH11	ADC	ADC end of conversion channel 0 in sequence, sample ready
22	ADC_CH21	ADC	ADC end of conversion channel 1 in sequence, sample ready
23	ADC_CH32	ADC	ADC end of conversion channel 2 in sequence, sample ready
24	ADC_CH42	ADC	ADC end of conversion channel 3 in sequence, sample ready
25	ADC_CH53	ADC	ADC end of conversion channel 4 in sequence, sample ready
26	ADC_CH63	ADC	ADC end of conversion channel 5 in sequence, sample ready
27	ADC_CH74	ADC	ADC end of conversion channel 6 in sequence, sample ready
28	ADC_CH84	ADC	ADC end of conversion channel 7 in sequence, sample ready
29	ENC_DW	AES	AES encryption processor requests download input data
30	ENC_UP	AES	AES encryption processor requests upload output data

<sup>9</sup> Using this trigger source must be aligned with port interrupt enable bits, PICTL.P0IENL/H and P1IEN. Note that all interrupt enabled port pins will generate a trigger and the trigger is generated on each level change on the enabled input (0-1 gives a trigger as does 1-0).

Peripherals : DMA Controller

**Table 42: DMA Configuration Data Structure**

Byte Offset	Bit	Name	Description
0	7:0	SRCADDR[15:8]	The DMA channel source address, high
1	7:0	SRCADDR[7:0]	The DMA channel source address, low
2	7:0	DESTADDR[15:8]	The DMA channel destination address, high. Note that flash memory is not directly writeable.
3	7:0	DESTADDR[7:0]	The DMA channel destination address, low. Note that flash memory is not directly writeable.
4	7:5	VLEN[2:0]	Variable length transfer mode. In word mode, bits 12:0 of the first word is considered as the transfer length.  000 Use LEN for transfer count 001 Transfer the number of bytes/words specified by first byte/word + 1 (up to a maximum specified by LEN). Thus transfer count excludes length byte/word 010 Transfer the number of bytes/words specified by first byte/word (up to a maximum specified by LEN). Thus transfer count includes length byte/word. 011 Transfer the number of bytes/words specified by first byte/word + 2 (up to a maximum specified by LEN). 100 Transfer the number of bytes/words specified by first byte/word + 3 (up to a maximum specified by LEN). 101 reserved 110 reserved 111 Alternative for using LEN as transfer count
4	4:0	LEN[12:8]	The DMA channel transfer count. Used as maximum allowable length when VLEN = 000/111. The DMA channel counts in words when in WORDSIZE mode, and in bytes otherwise.
5	7:0	LEN[7:0]	The DMA channel transfer count. Used as maximum allowable length when VLEN = 000/111. The DMA channel counts in words when in WORDSIZE mode, and in bytes otherwise.
6	7	WORDSIZE	Selects whether each DMA transfer shall be 8-bit (0) or 16-bit (1).
6	6:5	TMODE[1:0]	The DMA channel transfer mode: 00 : Single 01 : Block 10 : Repeated single 11 : Repeated block
6	4:0	TRIG[4:0]	Select DMA trigger to use 00000 : No trigger (writing to DMAREQ is only trigger) 00001 : The previous DMA channel finished 00010 – 11110 : Selects one of the triggers shown in Table 41, in that order.
7	7:6	SRCINC[1:0]	Source address increment mode (after each transfer): 00 : 0 bytes/words 01 : 1 bytes/words 10 : 2 bytes/words 11 : -1 bytes/words
7	5:4	DESTINC[1:0]	Destination address increment mode (after each transfer): 00 : 0 bytes/words 01 : 1 bytes/words 10 : 2 bytes/words 11 : -1 bytes/words
7	3	IRQMASK	Interrupt Mask for this channel. 0 : Disable interrupt generation 1 : Enable interrupt generation upon DMA channel done

Peripherals : DMA Controller

Byte Offset	Bit	Name	Description
7	2	M8	Mode of 8 <sup>th</sup> bit for VLEN transfer length; only applicable when WORDSIZE=0. 0 : Use all 8 bits for transfer count 1 : Use 7 LSB for transfer count
7	1:0	PRIORITY[1:0]	The DMA channel priority: 00 : Low, CPU has priority. 01 : Guaranteed, DMA at least every second try. 10 : High, DMA has priority 11 : Highest, DMA has priority. Reserved for DMA port access.

### 13.5.8 DMA registers

This section describes the SFR registers associated with the DMA Controller

#### DMAARM (0xD6) – DMA Channel Arm

Bit	Name	Reset	R/W	Description
7	ABORT	0	R/W	DMA abort. This bit is used to stop ongoing DMA transfers. Writing a 1 to this bit will abort all channels which are selected by setting the corresponding DMAARM bit to 1 0 : Normal operation 1 : Abort all selected channels
6:5	–	00	R/W	Not used
4	DMAARM4	0	R/W1	DMA arm channel 4 This bit must be set in order for any DMA transfers to occur on the channel. For non-repetitive transfer modes, the bit is automatically cleared upon completion.
3	DMAARM3	0	R/W1	DMA arm channel 3 This bit must be set in order for any DMA transfers to occur on the channel. For non-repetitive transfer modes, the bit is automatically cleared upon completion.
2	DMAARM2	0	R/W1	DMA arm channel 2 This bit must be set in order for any DMA transfers to occur on the channel. For non-repetitive transfer modes, the bit is automatically cleared upon completion.
1	DMAARM1	0	R/W1	DMA arm channel 1 This bit must be set in order for any DMA transfers to occur on the channel. For non-repetitive transfer modes, the bit is automatically cleared upon completion.
0	DMAARM0	0	R/W1	DMA arm channel 0 This bit must be set in order for any DMA transfers to occur on the channel. For non-repetitive transfer modes, the bit is automatically cleared upon completion.

Peripherals : DMA Controller

### DMAREQ (0xD7) – DMA Channel Start Request and Status

Bit	Name	Reset	R/W	Description
7:5	–	000	R0	Not used
4	DMAREQ4	0	R/W1 H0	DMA transfer request, channel 4 When set to 1 activate the DMA channel (has the same effect as a single trigger event.). Only by setting the armed bit to 0 in the DMAARM register, can the channel be stopped if already started. This bit is cleared when the DMA channel is granted access.
3	DMAREQ3	0	R/W1 H0	DMA transfer request, channel 3 When set to 1 activate the DMA channel (has the same effect as a single trigger event.). Only by setting the armed bit to 0 in the DMAARM register, can the channel be stopped if already started. This bit is cleared when the DMA channel is granted access.
2	DMAREQ2	0	R/W1 H0	DMA transfer request, channel 2 When set to 1 activate the DMA channel (has the same effect as a single trigger event.). Only by setting the armed bit to 0 in the DMAARM register, can the channel be stopped if already started. This bit is cleared when the DMA channel is granted access.
1	DMAREQ1	0	R/W1 H0	DMA transfer request, channel 1 When set to 1 activate the DMA channel (has the same effect as a single trigger event.). Only by setting the armed bit to 0 in the DMAARM register, can the channel be stopped if already started. This bit is cleared when the DMA channel is granted access.
0	DMAREQ0	0	R/W1 H0	DMA transfer request, channel 0 When set to 1 activate the DMA channel (has the same effect as a single trigger event.). Only by setting the armed bit to 0 in the DMAARM register, can the channel be stopped if already started. This bit is cleared when the DMA channel is granted access.

### DMA0CFGH (0xD5) – DMA Channel 0 Configuration Address High Byte

Bit	Name	Reset	R/W	Description
7:0	DMA0CFG[15:8]	0x00	R/W	The DMA channel 0 configuration address, high order

### DMA0CFGH (0xD4) – DMA Channel 0 Configuration Address Low Byte

Bit	Name	Reset	R/W	Description
7:0	DMA0CFG[7:0]	0x00	R/W	The DMA channel 0 configuration address, low order

### DMA1CFGH (0xD3) – DMA Channel 1-4 Configuration Address High Byte

Bit	Name	Reset	R/W	Description
7:0	DMA1CFG[15:8]	0x00	R/W	The DMA channel 1-4 configuration address, high order

## Peripherals : DMA Controller

**DMA1CFG (0xD2) – DMA Channel 1-4 Configuration Address Low Byte**

Bit	Name	Reset	R/W	Description
7:0	DMA1CFG[7:0]	0x00	R/W	The DMA channel 1-4 configuration address, low order

**DMAIRQ (0xD1) – DMA Interrupt Flag**

Bit	Name	Reset	R/W	Description
7:5	–	000	R/W0	Not used
4	DMAIF4	0	R/W0	DMA channel 4 interrupt flag. 0 : DMA channel transfer not complete 1 : DMA channel transfer complete/interrupt pending
3	DMAIF3	0	R/W0	DMA channel 3 interrupt flag. 0 : DMA channel transfer not complete 1 : DMA channel transfer complete/interrupt pending
2	DMAIF2	0	R/W0	DMA channel 2 interrupt flag. 0 : DMA channel transfer not complete 1 : DMA channel transfer complete/interrupt pending
1	DMAIF1	0	R/W0	DMA channel 1 interrupt flag. 0 : DMA channel transfer not complete 1 : DMA channel transfer complete/interrupt pending
0	DMAIF0	0	R/W0	DMA channel 0 interrupt flag. 0 : DMA channel transfer not complete 1 : DMA channel transfer complete/interrupt pending

## 13.6 16-bit timer, Timer1

Timer 1 is an independent 16-bit timer which supports typical timer/counter functions such as input capture, output compare and PWM functions. The timer has three independent capture/compare channels. The timer uses one I/O pin per channel. The timer is used for a wide range of control and measurement applications and the availability of up/down count mode with three channels will for example allow implementation of motor control applications.

The features of Timer 1 are as follows:

- Three capture/compare channels
- Rising, falling or any edge input capture
- Set, clear or toggle output compare
- Free-running, modulo or up/down counter operation
- Clock prescaler for divide by 1, 8, 32 or 128
- Interrupt request generated on each capture/compare and terminal count
- DMA trigger function

### 13.6.1 16-bit Timer Counter

The timer consists of a 16-bit counter that increments or decrements at each active clock edge. The period of the active clock edges is defined by the register bits `CLKCON.TICKSPD` which sets the global division of the system clock giving a variable clock tick frequency from 0.25 MHz to 32 MHz (given the use of the 32 MHz XOSC as clock source). This is further divided in Timer 1 by the prescaler value set by `T1CTL.DIV`. This prescaler value can be from 1, 8, 32, or 128. Thus the lowest clock frequency used by Timer 1 is 1953.125 Hz and the highest is 32 MHz when the 32 MHz crystal oscillator is used as system clock source. When the 16 MHz RC oscillator is used as system clock source then the highest clock frequency used by Timer 1 is 16 MHz.

The counter operates as either a free-running counter, a modulo counter or as an up/down counter for use in centre-aligned PWM.

It is possible to read the 16-bit counter value through the two 8-bit SFRs; `T1CNTH` and `T1CNTL`, containing the high-order byte and low-order byte respectively. When the `T1CNTL` is read, the high-order byte of the counter at that instant is buffered in `T1CNTH` so that the high-order byte can be read from `T1CNTH`. Thus `T1CNTL` shall always be read first before reading `T1CNTH`.

All write accesses to the `T1CNTL` register will reset the 16-bit counter.

The counter produces an interrupt request when the terminal count value (overflow) is reached. It is possible to start and halt the counter with `T1CTL` control register settings. The counter is started when a value other than 00 is written to `T1CTL.MODE`. If 00 is written to `T1CTL.MODE` the counter halts at its present value.

### 13.6.2 Timer 1 Operation

In general, the control register `T1CTL` is used to control the timer operation. The various modes of operation are described below.

### 13.6.3 Free-running Mode

In the free-running mode of operation the counter starts from 0x0000 and increments at each active clock edge. When the counter reaches 0xFFFF (overflow) the counter is loaded with 0x0000 and continues incrementing its value as shown in Figure 20. When the terminal count value 0xFFFF is

reached, both the `IRCON.T1IF` and the `T1CTL.OVFIF` flag are set. An interrupt request is generated if the corresponding interrupt mask bit `TIMIF.OVFIM` is set together with `IEN1.T1EN`. The free-running mode can be used to generate independent time intervals and output signal frequencies.

Peripherals : 16-bit timer, Timer1

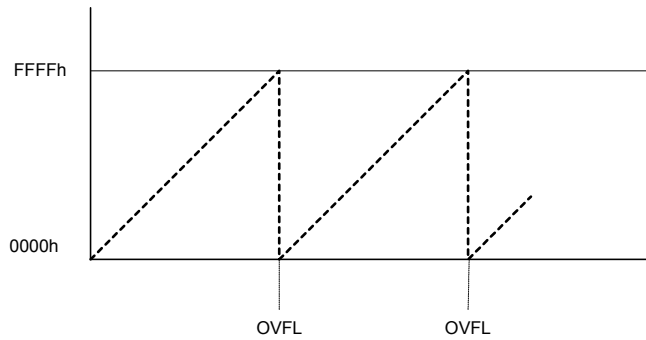

Figure 20: Free-running mode

13.6.4 Modulo Mode

When the timer operates in modulo mode the 16-bit counter starts at 0x0000 and increments at each active clock edge. When the counter reaches the terminal count value T1CC0 (overflow), held in registers T1CC0H:T1CC0L, the counter is reset to 0x0000 and continues to increment. Both the IRCON.T1IF and the flag T1CTL.OVFIF flag are set when the terminal

count value is reached. An interrupt request is generated if the corresponding interrupt mask bit TIMIF.OVFIM is set together with IEN1.T1EN. The modulo mode can be used for applications where a period other than 0xFFFF is required. The counter operation is shown in Figure 21.

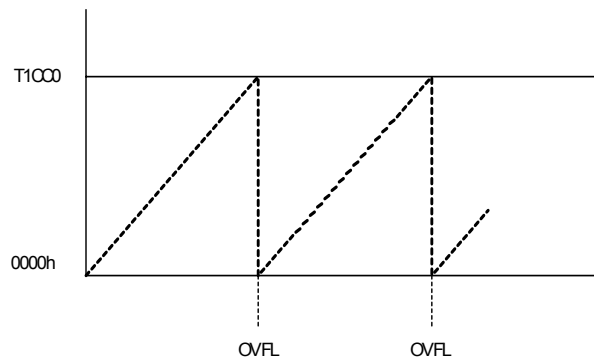

Figure 21: Modulo mode

13.6.5 Up/down Mode

In the up/down timer mode, the counter repeatedly starts from 0x0000 and counts up until the value held in T1CC0H:T1CC0L is reached and then the counter counts down until 0x0000 is reached as shown in Figure 22. This timer mode is used when symmetrical output pulses are required with a period other than 0xFFFF, and therefore allows

implementation of centre-aligned PWM output applications. Both the IRCON.T1IF and the T1CTL.OVFIF flag are set when the counter value reaches 0x0000 in the up/down mode. An interrupt request is generated if the corresponding interrupt mask bit TIMIF.OVFIM is set together with IEN1.T1EN.

Peripherals : 16-bit timer, Timer1

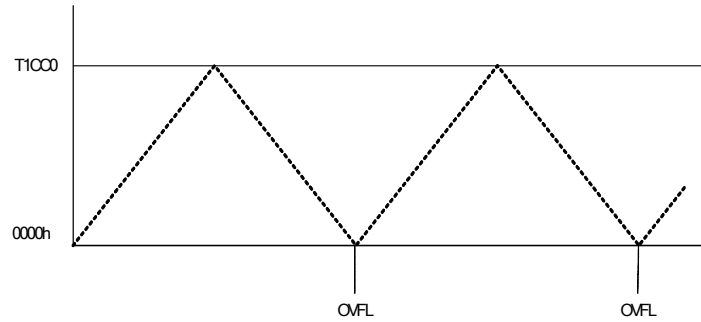

Figure 22 : Up/down mode

13.6.6 Channel Mode Control

The channel mode is set with each channel's control and status register `T1CCTLn`. The

settings include input capture and output compare modes.

13.6.7 Input Capture Mode

When a channel is configured as an input capture channel, the I/O pin associated with that channel, is configured as an input. After the timer has been started, a rising edge, falling edge or any edge on the input pin will trigger a capture of the 16-bit counter contents into the associated capture register. Thus the timer is able to capture the time when an external event takes place.

The channel input pin is synchronized to the internal system clock. Thus pulses on the input pin must have a minimum duration greater than the system clock period.

The contents of the 16-bit capture register is read out from registers `T1CCnH:T1CCnL`.

*Note: Before an I/O pin can be used by the timer, the required I/O pin must be configured as a Timer 1 peripheral pin as described in section 13.4.5 on page 79.*

When the capture takes place the `IRCON.T1IF` flag is set together with the interrupt flag for the channel is set. These bits are `T1CTL.CH0IF` for channel 0, `T1CTL.CH1IF` for channel 1, and `T1CTL.CH2IF` for channel 2. An interrupt request is generated if the corresponding interrupt mask bit on `T1CCTL0.IM`, `T1CCTL1.IM`, or `T1CCTL2.IM`, respectively, is set together with `IEN1.T1EN`.

13.6.8 Output Compare Mode

In output compare mode the I/O pin associated with a channel is set as an output. After the timer has been started, the contents of the counter are compared with the contents of the channel compare register `T1CCnH:T1CCnL`. If the compare register equals the counter contents, the output pin is set, reset or toggled according to the compare output mode setting of `T1CCTLn.CMP`. Note that all edges on output pins are glitch-free when operating in a given output compare mode. Writing to the compare register `T1CCnL` is buffered so that a value written to `T1CCnL` does not take effect until the corresponding high order register, `T1CCnH` is written. For output compare modes 1-3, a new value written to the compare register `T1CCnH:T1CCnL` takes effect after the registers have been written. For other output compare modes the new value written to the

compare register takes effect when the timer reaches `0x0000`.

Note that channel 0 has fewer output compare modes because `T1CC0H:T1CC0L` has a special function in modes 6 and 7, meaning these modes would not be useful for channel 0.

When a compare occurs, the interrupt flag for the channel is set. These bits are `T1CTL.CH0IF` for channel 0, `T1CTL.CH1IF` for channel 1, and `T1CTL.CH2IF` for channel 2, and the common interrupt flag `IRCON.T1IF`. An interrupt request is generated if the corresponding interrupt mask bit on `T1CCTL0.IM`, `T1CCTL1.IM`, or `T1CCTL2.IM`, respectively, is set together with `IRCON.T1IF`. When operating in up-down mode, the interrupt flag for channel 0 is set

when the counter reaches 0x0000 instead of when a compare occurs.

Examples of output compare modes in various timer modes are given in the following figures.

**Edge-aligned:** PWM output signals can be generated using the timer modulo mode and channels 1 and 2 in output compare mode 6 or 7 (defined by `T1CCTLn.CMP` bits, where `n` is 1 or 2) as shown in Figure 23. The period of the PWM signal is determined by the setting in `T1CC0` and the duty cycle is determined by `T1CCn`, where `n` is the PWM channel 1 or 2.

The timer free-running mode may also be used. In this case `CLKCON.TICKSPD` and the prescaler divider value in `T1CTL.DIV` bits set the period of the PWM signal. The polarity of the PWM signal is determined by whether output compare mode 6 or 7 is used.

PWM output signals can also be generated using output compare modes 4 and 5 as shown in Figure 23, or by using modulo mode as shown in Figure 24. Using output compare mode 4 and 5 is preferred for simple PWM.

**Centre-aligned:** PWM outputs can be generated when the timer up/down mode is selected. The channel output compare mode 4 or 5 (defined by `T1CCTLn.CMP` bits, where `n` is 1 or 2) is selected depending on required polarity of the PWM signal. The period of the

PWM signal is determined by `T1CC0` and the duty cycle for the channel output is determined by `T1CCn`, where `n` is the PWM channel 1 or 2.

The centre-aligned PWM mode is required by certain types of motor drive applications and typically less noise is produced than the edge-aligned PWM mode because the I/O pin transitions are not lined up on the same clock edge.

In some types of applications, a defined delay or dead time is required between outputs. Typically this is required for outputs driving an H-bridge configuration to avoid uncontrolled cross-conduction in one side of the H-bridge. The delay or dead-time can be obtained in the PWM outputs by using `T1CCn` as shown in the following:

Assuming that channel 1 and channel 2 are used to drive the outputs using timer up/down mode and the channels use output compare modes 4 and 5 respectively, then the timer period (in Timer 1 clock periods) is:

$$T_P = T1CC0 \times 2$$

and the dead time, i.e. the time when both outputs are low, (in Timer 1 clock periods) is given by:

$$T_D = T1CC1 - T1CC2$$

Peripherals : 16-bit timer, Timer1

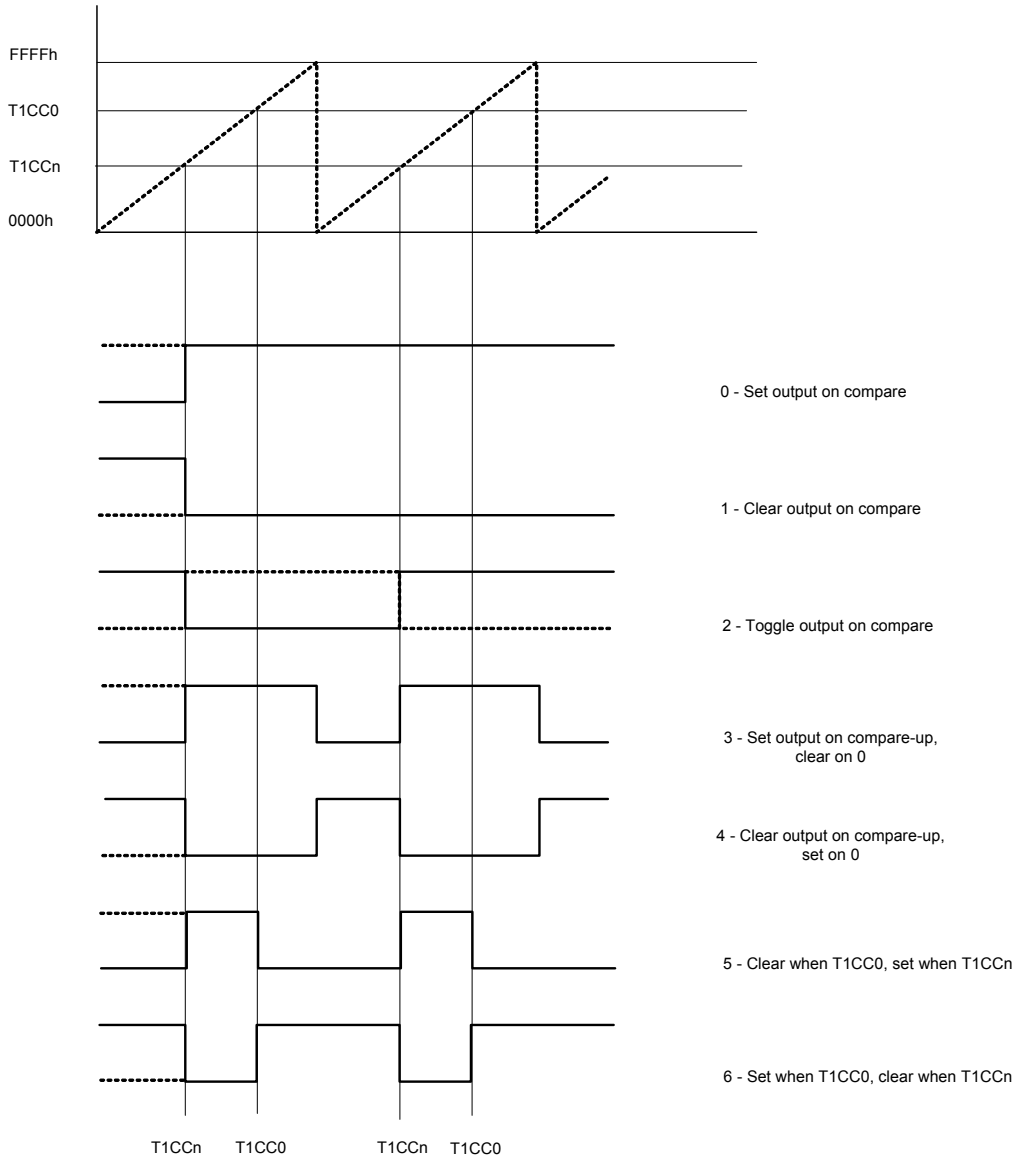

Figure 23: Output compare modes, timer free-running mode

Peripherals : 16-bit timer, Timer1

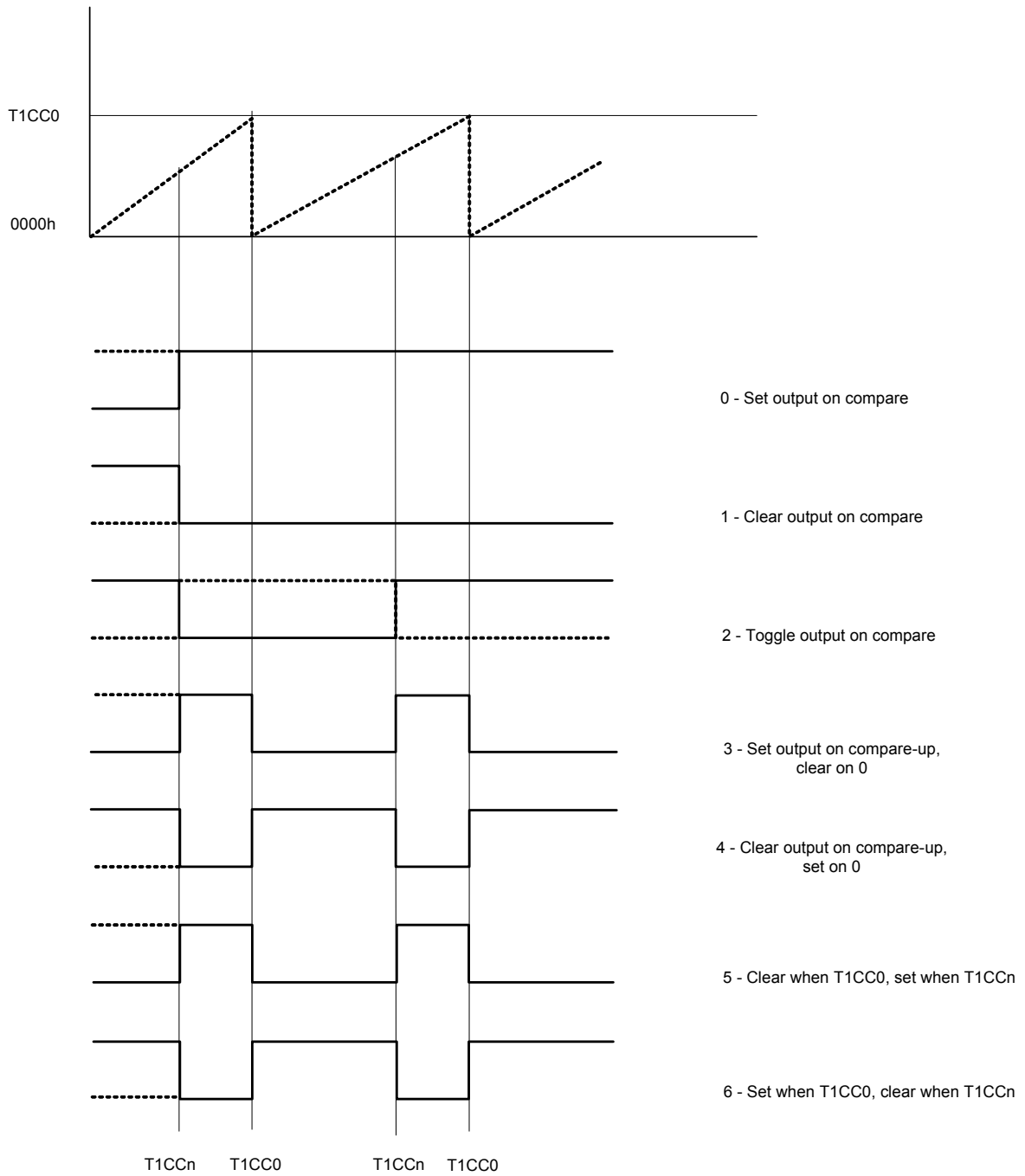

Figure 24: Output compare modes, timer modulo mode

Peripherals : 16-bit timer, Timer1

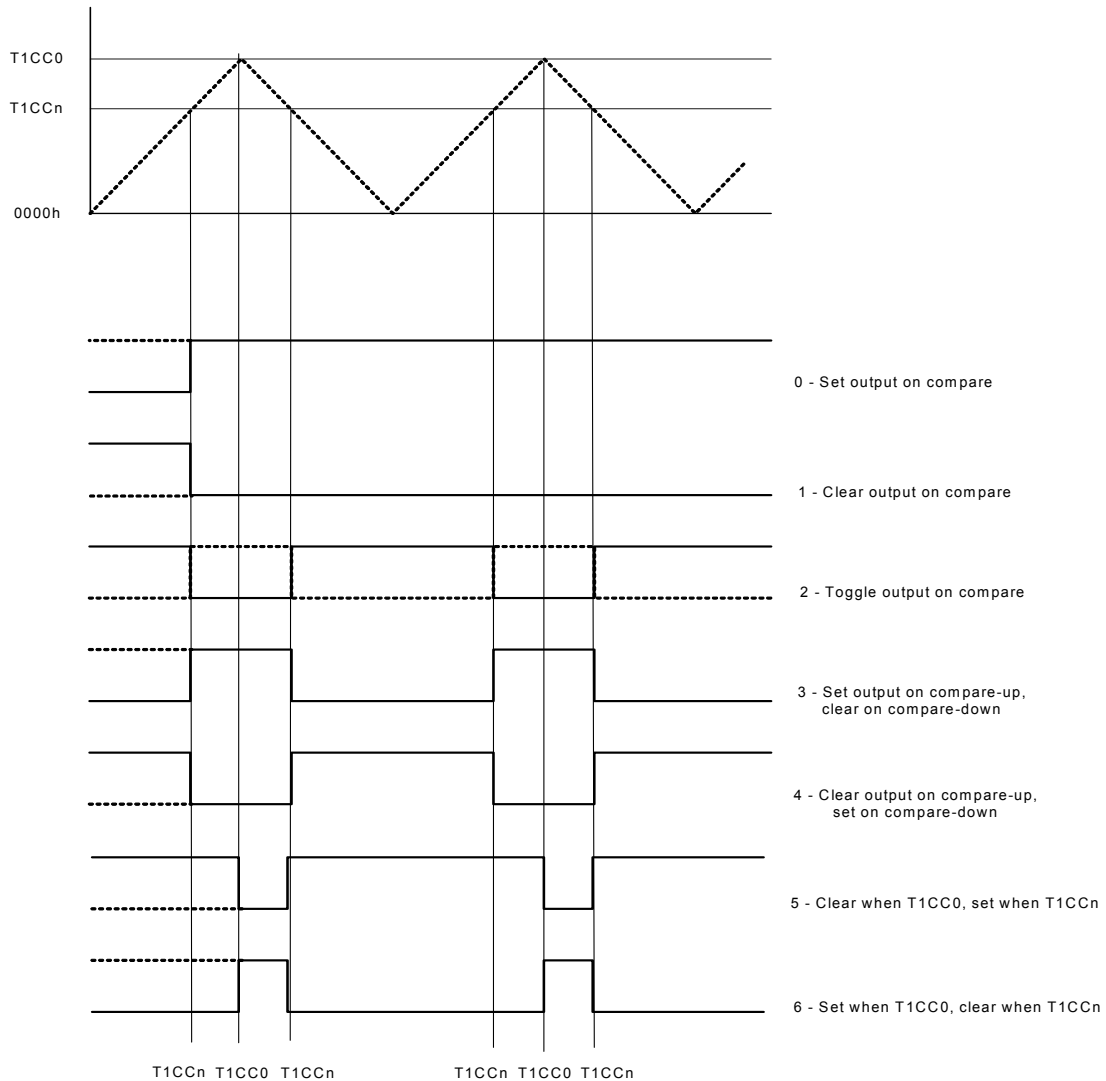

Figure 25: Output modes, timer up/down mode

13.6.9 Timer 1 Interrupts

There is one interrupt vector assigned to the timer. An interrupt request is generated when one of the following timer events occur:

- Counter reaches terminal count value (overflow, or turns around zero).
- Input capture event.
- Output compare event

The register bits T1CTL.OVFIF, T1CTL.CH0IF, T1CTL.CH1IF, and T1CTL.CH2IF contains the interrupt flags for the terminal count value event, and the three

channel compare/capture events, respectively. An interrupt request is only generated when the corresponding interrupt mask bit is set together with IEN1.T1EN. The interrupt mask bits are T1CCTL0.IM, T1CCTL1.IM, T1CCTL2.IM and TIMIF.OVFIM. If there are other pending interrupts, the corresponding interrupt flag must be cleared by software before a new interrupt request is generated. Also, enabling an interrupt mask bit will generate a new interrupt request if the corresponding interrupt flag is set.

13.6.10 Timer 1 DMA Triggers

There are three DMA triggers associated with Timer 1. These are DMA triggers T1\_CH0, T1\_CH1 and T1\_CH2 which are generated on timer compare events as follows:

- T1\_CH0 – channel 0 compare
- T1\_CH1 – channel 1 compare
- T1\_CH2 – channel 2 compare

### 13.6.11 Timer 1 Registers

This section describes the Timer 1 registers which consist of the following registers:

- T1CNTH – Timer 1 Count High
- T1CNTL – Timer 1 Count Low
- T1CTL – Timer 1 Control and Status
- T1CCTLx – Timer 1 Channel x Capture/Compare Control
- T1CCxH – Timer 1 Channel x Capture/Compare Value High

- T1CCxL – Timer 1 Channel x Capture/Compare Value Low

The TIMIF.OVFIM register bit resides in the TIMIF register, which is described together with Timer 3 and Timer 4 registers on page 118.

#### T1CNTH (0xE3) – Timer 1 Counter High

Bit	Name	Reset	R/W	Description
7:0	CNT[15:8]	0x00	R	Timer count high order byte. Contains the high byte of the 16-bit timer counter buffered at the time T1CNTL is read.

#### T1CNTL (0xE2) – Timer 1 Counter Low

Bit	Name	Reset	R/W	Description
7:0	CNT[7:0]	0x00	R/W	Timer count low order byte. Contains the low byte of the 16-bit timer counter. Writing anything to this register results in the counter being cleared to 0x0000.

#### T1CTL (0xE4) – Timer 1 Control and Status

Bit	Name	Reset	R/W	Description
7	CH2IF	0	R/W0	Timer 1 channel 2 interrupt flag. Set when the channel 2 interrupt condition occurs. Writing a 1 has no effect.
6	CH1IF	0	R/W0	Timer 1 channel 1 interrupt flag. Set when the channel 1 interrupt condition occurs. Writing a 1 has no effect.
5	CH0IF	0	R/W0	Timer 1 channel 0 interrupt flag. Set when the channel 0 interrupt condition occurs. Writing a 1 has no effect.
4	OVFIF	0	R/W0	Timer 1 counter overflow interrupt flag. Set when the counter reaches the terminal count value in free-running or modulo mode, and when zero is reached counting down in up-down mode. Writing a 1 has no effect.
3:2	DIV[1:0]	00	R/W	Prescaler divider value. Generates the active clock edge used to update the counter as follows: 00 Tick frequency/1 01 Tick frequency/8 10 Tick frequency/32 11 Tick frequency/128
1:0	MODE[1:0]	00	R/W	Timer 1 mode select. The timer operating mode is selected as follows: 00 Operation is suspended 01 Free-running, repeatedly count from 0x0000 to 0xFFFF 10 Modulo, repeatedly count from 0x0000 to T1CC0 11 Up/down, repeatedly count from 0x0000 to T1CC0 and from T1CC0 down to 0x0000

### T1CCTL0 (0xE5) – Timer 1 Channel 0 Capture/Compare Control

Bit	Name	Reset	R/W	Description
7	–	0	R/W	Reserved. Always set to 0
6	IM	1	R/W	Channel 0 interrupt mask. Enables interrupt request when set.
5:3	CMP[2:0]	000	R/W	Channel 0 compare mode select. Selects action on output when timer value equals compare value in T1CC0 000 Set output on compare 001 Clear output on compare 010 Toggle output on compare 011 Set output on compare-up, clear on 0 (clear on compare-down in up/down mode) 100 Clear output on compare-up, set on 0 (set on compare-down in up/down mode) 101 Not used 110 Not used 111 Not used
2	MODE	0	R/W	Mode. Select Timer 1 channel 0 capture or compare mode 0 Capture mode 1 Compare mode
1:0	CAP[1:0]	00	R/W	Channel 0 capture mode select 00 No capture 01 Capture on rising edge 10 Capture on falling edge 11 Capture on all edges

### T1CC0H (0xDB) – Timer 1 Channel 0 Capture/Compare Value High

Bit	Name	Reset	R/W	Description
7:0	T1CC0[15:8]	0x00	R/W	Timer 1 channel 0 capture/compare value, high order byte

### T1CC0L (0xDA) – Timer 1 Channel 0 Capture/Compare Value Low

Bit	Name	Reset	R/W	Description
7:0	T1CC0[7:0]	0x00	R/W	Timer 1 channel 0 capture/compare value, low order byte

### T1CCTL1 (0xE6) – Timer 1 Channel 1 Capture/Compare Control

Bit	Name	Reset	R/W	Description
7	–	0	R/W	Reserved. Always set to 0.
6	IM	1	R/W	Channel 1 interrupt mask. Enables interrupt request when set.
5:3	CMP[ 2 : 0 ]	000	R/W	Channel 1 compare mode select. Selects action on output when timer value equals compare value in T1CC1 000 Set output on compare 001 Clear output on compare 010 Toggle output on compare 011 Set output on compare-up, clear on 0 (clear on compare-down in up/down mode) 100 Clear output on compare-up, set on 0 (set on compare-down in up/down mode) 101 Clear when equal T1CC0, set when equal T1CC1 110 Set when equal T1CC0, clear when equal T1CC1 111 Not used
2	MODE	0	R/W	Mode. Select Timer 1 channel 1 capture or compare mode 0 Capture mode 1 Compare mode
1:0	CAP[ 1 : 0 ]	00	R/W	Channel 1 capture mode select 00 No capture 01 Capture on rising edge 10 Capture on falling edge 11 Capture on all edges

### T1CC1H (0xDD) – Timer 1 Channel 1 Capture/Compare Value High

Bit	Name	Reset	R/W	Description
7:0	T1CC1[ 15 : 8 ]	0x00	R/W	Timer 1 channel 1 capture/compare value, high order byte

### T1CC1L (0xDC) – Timer 1 Channel 1 Capture/Compare Value Low

Bit	Name	Reset	R/W	Description
7:0	T1CC1[ 7 : 0 ]	0x00	R/W	Timer 1 channel 1 capture/compare value, low order byte

**T1CCTL2 (0xE7) – Timer 1 Channel 2 Capture/Compare Control**

Bit	Name	Reset	R/W	Description
7	–	0	R/W	Reserved. Always set to 0.
6	IM	1	R/W	Channel 2 interrupt mask. Enables interrupt request when set.
5:3	CMP[2:0]	000	R/W	Channel 2 compare mode select. Selects action on output when timer value equals compare value in T1CC2 000 Set output on compare 001 Clear output on compare 010 Toggle output on compare 011 Set output on compare-up, clear on 0 (clear on compare-down in up/down mode) 100 Clear output on compare-up, set on 0 (set on compare-down in up/down mode) 101 Clear when equal T1CC0, set when equal T1CC2 110 Set when equal T1CC0, clear when equal T1CC2 111 Not used
2	MODE	0	R/W	Mode. Select Timer 1 channel 2 capture or compare mode 0 Capture mode 1 Compare mode
1:0	CAP[1:0]	00	R/W	Channel 2 capture mode select 00 No capture 01 Capture on rising edge 10 Capture on falling edge 11 Capture on all edges

**T1CC2H (0xDF) – Timer 1 Channel 2 Capture/Compare Value High**

Bit	Name	Reset	R/W	Description
7:0	T1CC2[15:8]	0x00	R/W	Timer 1 channel 2 capture/compare value, high order byte

**T1CC2L (0xDE) – Timer 1 Channel 2 Capture/Compare Value Low**

Bit	Name	Reset	R/W	Description
7:0	T1CC2[7:0]	0x00	R/W	Timer 1 channel 2 capture/compare value, low order byte

### 13.7 MAC Timer (Timer2)

The MAC Timer is mainly used to provide timing for 802.15.4 CSMA-CA algorithms and for general timekeeping in the 802.15.4 MAC layer. When the MAC Timer is used together with the Sleep Timer described in section 13.9, the timing function is provided even when the system enters low-power modes.

The main features of the MAC Timer are the following:

- 16-bit timer up-counter providing symbol/frame period: 16µs/320µs
- Adjustable period with accuracy 31.25 ns

#### 13.7.1 Timer Operation

This section describes the operation of the timer.

##### 13.7.1.1 General

After a reset the timer is in the timer IDLE mode where it is stopped. The timer starts running when `T2CNF.RUN` is set to 1. The timer will then enter the timer RUN mode. The entry is either immediate or it is performed synchronous with the 32 kHz clock. See section 13.7.4 for a description of the synchronous start and stop mode.

##### 13.7.1.2 Up Counter

The MAC Timer contains a 16-bit timer, which increments during each clock cycle.

##### 13.7.1.3 Timer overflow

When the timer is about to *count* to a value that is equal to or greater than the timer period set by registers `T2CAPHPH:T2CAPLPL`, a timer overflow occurs. When the timer overflow occurs, the timer is set to the difference between the value it is about to count to and the timer period, e.g. if the next value of the

##### 13.7.1.4 Timer delta increment

The timer period may be adjusted once during a timer period by writing a timer delta value. When a timer delta value is written to the registers `T2THD:T2TLD`, the 16-bit timer halts at its current value and a delta counter starts counting. The delta counter starts counting from the delta value written, down to zero. Once the delta counter reaches zero, the 16-bit timer starts counting again.

##### 13.7.1.5 Timer Compare

A timer compare occurs when the timer is about to *count* to a value that is equal or greater than the 8-bit compare value held in the `T2CMP` register. Note that the compare

- 8-bit timer compare function
- 20-bit overflow count
- 20-bit overflow count compare function
- Start of Frame Delimiter capture function.
- Timer start/stop synchronous with 32.768 kHz clock and timekeeping maintained by Sleep Timer.
- Interrupts generated on compare and overflow
- DMA trigger capability

Once the timer is running in RUN mode, it can be stopped by writing a 0 to `T2CNF.RUN`. The timer will then enter the timer IDLE mode. The stopping of the timer is performed either immediately or it is performed synchronous with the 32 kHz clock

timer would be 0x00FF and the timer period is 0x00FF then the timer is set to 0x000. If the overflow interrupt mask bit `T2PEROF2.PERIM` is 1, an interrupt request is generated. The interrupt flag bit `T2CNF.PERIF` is set to 1 regardless of the interrupt mask value.

The delta counter decrements by the same rate as the timer. When the delta counter has reached zero it will not start counting again until the delta value is written once again. In this way a timer period may be increased by the delta value in order to make adjustments to the timer overflow events over time.

value is only 8 bits so the compare is made between the compare value and either the most significant byte or the least significant byte of the timer. The selection of which part of

Peripherals : MAC Timer (Timer2)

the timer is to be compared is set by the T2CNF.CMSEL bit.

When a timer compare occurs the interrupt flag T2CNF.CMPIF is set to 1. An interrupt

13.7.1.6 Capture Input

The MAC timer has a timer capture function which captures at the time when the start of frame delimiter (SFD) status in the radio goes high. Refer to sections 14.6 and 14.9 starting on page 157 for a description of the SFD.

When the capture event occurs the current timer value will be captured into the capture

13.7.1.7 Overflow count

At each timer overflow, the 20-bit overflow counter is incremented by 1. The overflow counter value is read through the SFR registers T2OF2:T2OF1:T2OF0. Note that the register contents in T2OF2:T2OF1 is latched when T2OF0 is read, meaning that T2OF0 must always be read first.

13.7.1.8 Overflow count compare

A compare value may be set for the overflow counter. The compare value is set by writing to T2PEROF2:T2PEROF1:T2PEROF0. When the overflow count value is equal or greater than the set compare value an overflow compare event occurs. If the overflow compare interrupt mask bit T2PEROF2.OFCMPIM is 1, an interrupt request is generated. The interrupt

13.7.2 Interrupts

The Timer has three individually maskable interrupt sources. These are the following:

- Timer overflow
- Timer compare
- Overflow count compare

The interrupt flags are given in the T2CNF registers. The interrupt flag bits are set only by hardware and may be cleared only by writing to the SFR register.

13.7.3 DMA Triggers

Timer 2 can generate two DMA triggers – T2\_COMP and T2\_OVFL which are activated as follows:

13.7.4 Timer start/stop synchronization

This section describes the synchronized timer start and stop.

request is also generated if the interrupt mask T2PEROF2.CMPIM is set to 1.

register. The capture value can be read from the registers T2CAPHPH:T2CAPLPL. The value of the overflow count is also captured (see section 13.7.1.7) at the time of the capture event and can be read from the registers T2PEROF2:T2PEROF1:T2PEROF0.

**Overflow count update:** The overflow count value may be updated by writing to the registers T2OF2:T2OF1:T2OF0 when the timer is in the IDLE or RUN state.

Note that the last data written to registers T2OF1:T2OF0 is latched when T2OF2 is written, meaning that T2OF2 must always be written last.

flag bit T2CNF.OFCMPIF is set to 1 regardless of the interrupt mask value. It should be noted that if a capture event occurs when the T2PEROF2 is written to the three most significant bits will not be updated. In order to address this one should either write twice to this register while interrupts are disabled, or read back and verify that written data was set.

Each interrupt source may be masked by the mask bits in the T2PEROF2 register. An interrupt is generated when the corresponding mask bit is set, otherwise the interrupt will not be generated. The interrupt flag bit is set, however disregarding the state of the interrupt mask bit.

- T2\_COMP: Timer 2 compare event
- T2\_OVFL: Timer 2 overflow event

13.7.4.1 General

The Timer can be started and stopped synchronously with the 32kHz clock rising edge. Note this event is derived from a 32kHz clock signal, but is synchronous with the 32MHz system clock and thus has a period approximately equal the 32kHz clock period.

At the time of a synchronous start the timer is reloaded with new calculated values for the timer and overflow count such that it appears that the timer has not been stopped (e.g. in PM1/2 mode).

13.7.4.2 Timer synchronous stop

After the timer has started running, i.e. entered timer RUN mode it is stopped synchronously by writing 0 to T2CNF.RUN when T2CNF.SYNC is 1. After T2CNF.RUN has been set to 0, the

timer will continue running until the 32kHz clock rising edge is sampled as 1. When this occurs the timer is stopped and the current Sleep timer value is stored.

13.7.4.3 Timer synchronous start

When the timer is in the IDLE mode it is started synchronously by writing 1 to T2CNF.RUN when T2CNF.SYNC is 1. After T2CNF.RUN has been set to 1, the timer will remain in the IDLE mode until the 32kHz clock rising edge is detected. When this occurs the timer will first calculate new values for the 16-bit timer value and for the 20-bit timer overflow count, based on the current and stored Sleep timer values and the current 16-bit timer values. The new MAC Timer and overflow count values are loaded into the timer and the timer enters the RUN mode. This synchronous start process takes 75 clock cycles from the

time when the 32kHz clock rising edge is sampled high. The synchronous start and stop function requires that the system clock frequency is selected to be 32MHz. If the 16MHz clock is selected, there will be an offset added to the new calculated value.

The method for calculating the new MAC Timer value and overflow count value is given below. Due to the fact that the MAC Timer clock and Sleep timer clocks are asynchronous with a non-integer clock ratio there will be an error of maximum  $\pm 1$  in calculated timer value compared to the ideal timer value.

**Calculation of new timer value and overflow count value:**

$$N_c = \text{CurrentSleepTimerValue}$$

$$N_s = \text{StoredSleepTimerValue}$$

$$K_{ck} = \text{ClockRatio} = 976.5625^{10}$$

$$stw = \text{SleepTimerWidth} = 24$$

$$P = \text{Timer2Period}$$

$$O_c = \text{CurrentOverflowCountValue}$$

$$T_c = \text{CurrentTimerValue}$$

$$T_{OH} = \text{Overhead} = 75$$

$$N_t = N_c - N_s$$

$$N_t \leq 0 \Rightarrow N_d = 2^{stw} + N_t; N_t > 0 \Rightarrow N_d = N_t$$

$$C = N_d \cdot K_{ck} + T_c + T_{OH} \text{ (Rounded to nearest integer value)}$$

$$T = C \bmod P$$

$$O = \frac{(C - T)}{P} + O_c$$

$$\text{Timer2Value} = T$$

$$\text{Timer2OverflowCount} = O$$

<sup>10</sup> Clock ratio of MAC Timer clock frequency (32 MHz - XOSC) and Sleep timer clock frequency (32.768 kHz - XOSC)

For a given Timer 2 period value, P, there is a maximum duration between Timer2 synchronous stop and start for which the timer value is correctly updated after starting. The maximum value is given in terms of the number of Sleep Timer clock periods, i.e. 32kHz clock periods,  $T_{ST(max)}$ :

$$T_{ST(max)} \leq \frac{(2^{20} - 1) \times P + T_{OH}}{K_{ck}}$$

The maximum period controlled by T2CAPHPH and T2CAPHPL is defined when these registers are 0x0000. When operation in power modes PM1 or PM2 this will always result in an overflow and both overflow and timer counter will be set to 0xFFFF. The value 0x0000 in

Peripherals : MAC Timer (Timer2)

T2CAPHPH and T2CAPHPL should be avoided

when using Timer2 in PM1 or PM2.

13.7.5 Timer 2 Registers

The SFR registers associated with Timer 2 are listed in this section. These registers are the following:

- T2CNF – Timer 2 Configuration
- T2HD – Timer 2 Count/Delta High
- T2LD – Timer 2 Count/Delta Low
- T2CMP – Timer 2 Compare
- T2OF2 – Timer 2 Overflow Count 2
- T2OF1 – Timer 2 Overflow Count 1

- T2OF0 – Timer 2 Overflow Count 0
- T2CAPHPH – Timer 2 Capture/Period High
- T2CAPLPL – Timer 2 Capture/Period Low
- T2PEROF2 – Timer 2 Overflow Capture/Compare 2
- T2PEROF1 – Timer 2 Overflow Capture/Compare 1
- T2PEROF0 – Timer 2 Overflow Capture/Compare 0

**T2CNF (0xC3) – Timer 2 Configuration**

Bit	Name	Reset	R/W	Description
7	CMPIF	0	R/W0	Timer compare interrupt flag. This bit is set to 1 when a timer compare event occurs. Cleared by software only. Writing a 1 to this bit has no effect.
6	PERIF	0	R/W0	Overflow interrupt flag. This bit is set to 1 when a period event occurs. Cleared by software only. Writing a 1 to this bit has no effect.
5	OFCMPIF	0	R/W0	Overflow compare interrupt flag. This bit is set to 1 when a overflow compare occurs. Cleared by software only. Writing a 1 to this bit has no effect.
4	-	0	R0	Not used. Read as 0
3	CMSEL	0	R/W	Timer compare source select. 0 Compare with 16-bit Timer bits [15:8] 1 Compare with 16-bit Timer bits [7:0]
2	-	0	R/W	Reserved. Always set to 0
1	SYNC	1	R/W	Enable synchronized start and stop. 0 start and stop of timer is immediate 1 start and stop of timer is synchronized with 32.768 kHz edge and new timer values are reloaded.
0	RUN	0	R/W	Dual function: timer start / timer status. Writing this bit will start or stop the timer. 0 stop timer 1 start timer  Reading this bit the current state of the timer is returned. 0 timer is stopped (IDLE state) 1 timer is running (RUN state)  Note when SYNC =1 (the reset condition), the timer status does not change immediately when the timer is started or stopped. Instead the timer status is changed when the actual synchronous start/stop takes place. Prior to the synchronous start/stop event, the read value of RUN will differ from the last value written.

### T2THD (0xA7) – Timer 2 Timer Value High Byte

Bit	Name	Reset	R/W	Description
7:0	THD[7:0]	0x00	R/W	<p>The value read from this register is the high-order byte of the timer value. The high-order byte read is from timer value at the last instant when T2TLD was read.</p> <p>The value written to this register while the timer is running is the high-order byte of the timer delta counter value. The low-order byte of this value is the value last written to T2TLD. The timer will halt for delta clock cycles.</p> <p>The value written to this register while the timer is idle will be written to the high-order byte of the timer.</p>

### T2TLD (0xA6) – Timer 2 Timer Value Low Byte

Bit	Name	Reset	R/W	Description
7:0	TLD[7:0]	0x00	R/W	<p>The value read from this register is the low-order byte of the timer value.</p> <p>The value written to this register while the timer is running is the low-order byte of the timer delta counter value. The timer will halt for delta clock cycles. The value written to T2TLD will not take effect until T2THD is written.</p> <p>The value written to this register while the timer is idle will be written to the low-order byte of the timer.</p>

### T2CMP (0x94) – Timer 2 Compare Value

Bit	Name	Reset	R/W	Description
7:0	CMP[7:0]	0x00	R/W	<p>Timer Compare value. A timer compare occurs when the compare source selected by T2CNF.CMSEL equals the value held in CMP.</p>

### T2OF2 (0xA3) – Timer 2 Overflow Count 2

Bit	Name	Reset	R/W	Description
7:4	-	0000	R0	Not used, read as 0
3:0	OF2[3:0]	0x00	R/W	<p>Overflow count. High bits T2OF[19:16]. T2OF is incremented by 1 each time the timer overflows i.e. timer counts to a value greater or equal to period. When reading this register, the value read is the value latched when T2OF0 was read. Writing to this register when the timer is in IDLE or RUN states will force the overflow count to be set to the value written to T2OF2:T2OF1:T2OF0. If the count would otherwise be incremented by 1 when this register is written then 1 is added to the value written.</p>

### T2OF1 (0xA2) – Timer 2 Overflow Count 1

Bit	Name	Reset	R/W	Description
7:0	OF1[7:0]	0x00	R/W	<p>Overflow count. Middle bits T2OF[15:8]. T2OF is incremented by 1 each time the timer overflows i.e. timer counts to a value greater or equal to period. When reading this register, the value read is the value latched when T2OF0 was read. Writing to this register when the timer is in IDLE or RUN states will force the overflow count to be set to the value written to T2OF2:T2OF1:T2OF0. If the count would otherwise be incremented by 1 when this register is written then 1 is added to the value written. The value written will not take effect until T2OF2 is written.</p>

Peripherals : MAC Timer (Timer2)

### T2OF0 (0xA1) – Timer 2 Overflow Count 0

Bit	Name	Reset	R/W	Description
7:0	OF0[7:0]	0x00	R/W	Overflow count. Low bits T2OF[7:0]. T2OF is incremented by 1 each time the timer overflows i.e. timer counts to a value greater or equal to period. Writing to this register when the timer is in IDLE or RUN states will force the overflow count to be set to the value written to T2OF2:T2OF1:T2OF0. If the count would otherwise be incremented by 1 when this register is written then 1 is added to the value written. The value written will not take effect until T2OF2 is written.

### T2CAPHPH (0xA5) – Timer 2 Period High Byte

Bit	Name	Reset	R/W	Description
7:0	CAPHPH[7:0]	0xFF	R/W	Capture value high/timer period high. Writing this register sets the high order bits [15:8] of the timer period. Reading this register gives the high order bits [15:8] of the timer value at the last capture event.

### T2CAPLPL (0xA4) – Timer 2 Period Low Byte

Bit	Name	Reset	R/W	Description
7:0	CAPLPL[7:0]	0xFF	R/W	Capture value low/timer period low. Writing this register sets the low order bits [7:0] of the timer period. Reading this register gives the low order bits [7:0] of the timer value at the last capture event.

### T2PEROF2 (0x9E) – Timer 2 Overflow Capture/Compare 2

Bit	Name	Reset	R/W	Description
7	CMPIM	0	R/W	Compare interrupt mask. 0: No interrupt is generated on compare event 1: Interrupt is generated on compare event.
6	PERIM	0	R/W	Overflow interrupt mask 0: No interrupt is generated on timer overflow 1: Interrupt is generated on timer overflow
5	OFCMPIM	0	R/W	Overflow count compare interrupt mask 0: No interrupt is generated on overflow count compare 1: Interrupt is generated on overflow count compare
4	-	0	R0	Not used, read as 0
3:0	PEROF2[3:0]	0000	R/W	Overflow count capture/Overflow count compare value. Writing these bits set the high bits [19:16] of the overflow count compare value. Reading these bits returns the high bits [19:16] of the overflow count value at the time of the last capture event.

### T2PEROF1 (0x9D) – Timer 2 Overflow Capture/Compare 1

Bit	Name	Reset	R/W	Description
7:0	PEROF1[7:0]	0x00	R/W	Overflow count capture /Overflow count compare value. Writing these bits set the middle bits [15:8] of the overflow count compare value. Reading these bits returns the middle bits [15:8] of the overflow count value at the time of the last capture event.

### T2PEROF0 (0x9C) – Timer 2 Overflow Capture/Compare 0

Bit	Name	Reset	R/W	Description
7:0	PEROF0[7:0]	0x00	R/W	Overflow count capture /Overflow count compare value. Writing these bits set the low bits [7:0] of the overflow count compare value. Reading these bits returns the low bits [7:0] of the overflow count value at the time of the last capture event.

### 13.8 8-bit timers, Timer 3 and Timer 4

Timer 3 and 4 are two 8-bit timers which support typical timer/counter functions such as output compare and PWM functions. The timers have two independent compare channels each using one IO per channel.

Features of Timer 3/4 are as follows:

- Two compare channels
- Set, clear or toggle output compare
- Clock prescaler for divide by 1, 2, 4, 8, 16, 32, 64, 128
- Interrupt request generated on each compare and terminal count event
- DMA trigger function

#### 13.8.1 8-bit Timer Counter

All timer functions are based on the main 8-bit counter found in Timer 3/4. The counter increments or decrements at each active clock edge. The period of the active clock edges is defined by the register bits `CLKCON.TICKSPD` which is further divided by the prescaler value set by `TxCTL.DIV` (where x refers to the timer number, 3 or 4). The counter operates as either a free-running counter, a down counter, a modulo counter or as an up/down counter.

It is possible to read the 8-bit counter value through the SFR `TxCNT` where x refers to the timer number, 3 or 4.

The possibility to clear and halt the counter is given with `TxCTL` control register settings. The counter is started when a 1 is written to `TxCTL.START`. If a 0 is written to `TxCTL.START` the counter halts at its present value.

#### 13.8.2 Timer 3/4 Mode Control

In general the control register `TxCTL` is used to control the timer operation.

##### 13.8.2.1 Free-running Mode

In the free-running mode of operation the counter starts from 0x00 and increments at each active clock edge. When the counter reaches 0xFF the counter is loaded with 0x00 and continues incrementing its value. When the terminal count value 0xFF is reached (i.e. an overflow occurs), the interrupt flag

`TIMIF.TxOVFIF` is set. If the corresponding interrupt mask bit `TxCTL.OVFIM` is set, an interrupt request is generated. The free-running mode can be used to generate independent time intervals and output signal frequencies.

##### 13.8.2.2 Down mode

In the down mode, after the timer has been started, the counter is loaded with the contents in `TxCC`. The counter then counts down to 0x00. The flag `TIMIF.TxOVFIF` is set when 0x00 is reached. If the corresponding interrupt

mask bit `TxCTL.OVFIM` is set, an interrupt request is generated. The timer down mode can generally be used in applications where an event timeout interval is required.

##### 13.8.2.3 Modulo Mode

When the timer operates in modulo mode the 8-bit counter starts at 0x00 and increments at each active clock edge. When the counter reaches the terminal count value held in register `TxCC` the counter is reset to 0x00 and continues to increment. The flag

`TIMIF.TxOVFIF` is set when on this event. If the corresponding interrupt mask bit `TxCTL.OVFIM` is set, an interrupt request is generated. The modulo mode can be used for applications where a period other than 0xFF is required.

##### 13.8.2.4 Up/down Mode

In the up/down timer mode, the counter repeatedly starts from 0x00 and counts up until the value held in `TxCC` is reached and then the counter counts down until 0x00 is reached. This timer mode is used when symmetrical output pulses are required with a period other than 0xFF, and therefore allows

implementation of centre-aligned PWM output applications.

Clearing the counter by writing to `TxCTL.CLR` will also reset the count direction to the count up from 0x00 mode.

### 13.8.3 Channel Mode Control

The channel modes for each channel; 0 and 1, are set by the control and status registers

$Tx\text{CCTLn}$  where n is the channel number, 0 or 1. The settings include output compare modes.

### 13.8.4 Output Compare Mode

In output compare mode the I/O pin associated with a channel shall be set to an output. After the timer has been started, the content of the counter is compared with the contents of the channel compare register  $Tx\text{CC0n}$ . If the compare register equals the counter contents, the output pin is set, reset or toggled according to the compare output mode setting of  $Tx\text{CCTL.CMP1}$ :0. Note that all edges on output pins are glitch-free when operating in a given compare output mode.

Writing to the compare register  $Tx\text{CC0}$  does not take effect on the output compare value until the counter value is 0x00. Writing to the compare register  $Tx\text{CC1}$  takes effect immediately.

For simple PWM use, output compare modes 4 and 5 are preferred.

When a compare occurs the interrupt flag corresponding to the actual channel is set. This is  $TIMIF.Tx\text{CHnIF}$ . An interrupt request is generated if the corresponding interrupt mask bit  $Tx\text{CCTLn.IM}$  is set.

### 13.8.5 Timer 3 and 4 interrupts

There is one interrupt vector assigned to each of the timers. These are T3 and T4. An interrupt request is generated when one of the following timer events occur:

- Counter reaches terminal count value.
- Output compare event

The SFR register  $TIMIF$  contains all interrupt flags for Timer 3 and Timer 4. The register bits  $TIMIF.Tx\text{OVFI}$  and  $TIMIF.Tx\text{CHnIF}$ , contains the interrupt flags for the two terminal

count value events and the four channel compare events, respectively. An interrupt request is only generated when the corresponding interrupt mask bit is set. If there are other pending interrupts, the corresponding interrupt flag must be cleared by the CPU before a new interrupt request can be generated. Also, enabling an interrupt mask bit will generate a new interrupt request if the corresponding interrupt flag is set.

### 13.8.6 Timer 3 and Timer 4 DMA triggers

There are two DMA triggers associated with Timer 3 and two DMA triggers associated with Timer 4. These are the following:

- T3\_CH0 : Timer 3 channel 0 compare
- T3\_CH1 : Timer 3 channel 1 compare

- T4\_CH0 : Timer 4 channel 0 compare
- T4\_CH1 : Timer 4 channel 1 compare

Refer to section 13.5 on page 88 for a description on use of DMA channels.

### 13.8.7 Timer 3 and 4 registers

#### T3CNT (0xCA) – Timer 3 Counter

Bit	Name	Reset	R/W	Description
7:0	CNT[7:0]	0x00	R	Timer count byte. Contains the current value of the 8-bit counter.

## T3CTL (0xCB) – Timer 3 Control

Bit	Name	Reset	R/W	Description
7:5	DIV[ 2 : 0 ]	000	R/W	<p>Prescaler divider value. Generates the active clock edge used to clock the timer from CLKCON . TICKSPD as follows:</p> <p>000 Tick frequency /1            001 Tick frequency /2            010 Tick frequency /4            011 Tick frequency /8            100 Tick frequency /16            101 Tick frequency /32            110 Tick frequency /64            111 Tick frequency /128</p>
4	START	0	R/W	Start timer. Normal operation when set, suspended when cleared
3	OVFIM	1	R/W0	<p>Overflow interrupt mask</p> <p>0 : interrupt is disabled            1 : interrupt is enabled</p>
2	CLR	0	R0/W1	Clear counter. Writing high resets counter to 0x00
1:0	MODE[ 1 : 0 ]	00	R/W	<p>Timer 3 mode. Select the mode as follows:</p> <p>00 Free running, repeatedly count from 0x00 to 0xFF            01 Down, count from T3CC0 to 0x00            10 Modulo, repeatedly count from 0x00 to T3CC0            11 Up/down, repeatedly count from 0x00 to T3CC0 and down to 0x00</p>

### T3CCTL0 (0xCC) – Timer 3 Channel 0 Compare Control

Bit	Name	Reset	R/W	Description
7	–	0	R0	Unused
6	IM	1	R/W	Channel 0 interrupt mask 0 : interrupt is disabled 1 : interrupt is enabled
5:3	CMP [ 2 : 0 ]	000	R/W	Channel 0 compare output mode select. Specified action on output when timer value equals compare value in T3CC0  000 Set output on compare 001 Clear output on compare 010 Toggle output on compare 011 Set output on compare-up, clear on 0 (clear on compare-down in up/down mode) 100 Clear output on compare-up, set on 0 (set on compare-down in up/down mode) 101 Set output on compare, clear on 0xFF 110 Clear output on compare, set on 0x00 111 Not used
2	MODE	0	R/W	Mode. Select Timer 3 channel 0 compare mode 0 Compare disabled 1 Compare enable
1:0	–	00	R/W	Reserved. Set to 00.

### T3CC0 (0xCD) – Timer 3 Channel 0 Compare Value

Bit	Name	Reset	R/W	Description
7:0	VAL [ 7 : 0 ]	0x00	R/W	Timer compare value channel 0

Peripherals : 8-bit timers, Timer 3 and Timer 4

### T3CCTL1 (0xCE) – Timer 3 Channel 1 Compare Control

Bit	Name	Reset	R/W	Description
7	–	0	R0	Unused
6	IM	1	R/W	Channel 1 interrupt mask 0 : interrupt is disabled 1 : interrupt is enabled
5:3	CMP [ 2 : 0 ]	000	R/W	Channel 1 compare output mode select. Specified action on output when timer value equals compare value in T3CC1  000 Set output on compare 001 Clear output on compare 010 Toggle output on compare 011 Set output on compare-up, clear on 0 (clear on compare-down in up/down mode) 100 Clear output on compare-up, set on 0 (set on compare-down in up/down mode) 101 Set output on compare, clear on T3CC0 110 Clear output on compare, set on T3CC0 111 Not used
2	MODE	0	R/W	Mode. Select Timer 3 channel 1 compare mode  0 Compare disabled 1 Compare enabled
1:0	–	00	R/W	Reserved. Set to 00.

### T3CC1 (0xCF) – Timer 3 Channel 1 Compare Value

Bit	Name	Reset	R/W	Description
7:0	VAL [ 7 : 0 ]	0x00	R/W	Timer compare value channel 1

### T4CNT (0xEA) – Timer 4 Counter

Bit	Name	Reset	R/W	Description
7:0	CNT [ 7 : 0 ]	0x00	R	Timer count byte. Contains the current value of the 8-bit counter.

### T4CTL (0xEB) – Timer 4 Control

Bit	Name	Reset	R/W	Description
7:5	DIV[ 2 : 0 ]	000	R/W	<p>Prescaler divider value. Generates the active clock edge used to clock the timer from CLKCON . TICKSPD as follows:</p> <p>000 Tick frequency /1            001 Tick frequency /2            010 Tick frequency /4            011 Tick frequency /8            100 Tick frequency /16            101 Tick frequency /32            110 Tick frequency /64            111 Tick frequency /128</p>
4	START	0	R/W	Start timer. Normal operation when set, suspended when cleared
3	OVFIM	1	R/W0	Overflow interrupt mask
2	CLR	0	R0/W1	Clear counter. Writing high resets counter to 0x00
1:0	MODE[ 1 : 0 ]	00	R/W	<p>Timer 4 mode. Select the mode as follows:</p> <p>00 Free running, repeatedly count from 0x00 to 0xFF            01 Down, count from T4CC0 to 0x00            10 Modulo, repeatedly count from 0x00 to T4CC0            11 Up/down, repeatedly count from 0x00 to T4CC0 and down to 0x00</p>

### T4CCTL0 (0xEC) – Timer 4 Channel 0 Compare Control

Bit	Name	Reset	R/W	Description
7	–	0	R0	Unused
6	IM	1	R/W	Channel 0 interrupt mask
5:3	CMP [ 2 : 0 ]	000	R/W	Channel 0 compare output mode select. Specified action on output when timer value equals compare value in T4CC0 000 Set output on compare 001 Clear output on compare 010 Toggle output on compare 011 Set output on compare-up, clear on 0 (clear on compare-down in up/down mode) 100 Clear output on compare-up, set on 0 (set on compare-down in up/down mode) 101 Set output on compare, clear on 0x00 110 Clear output on compare, set on 0x00 111 Not used
2	MODE	0	R/W	Mode. Select Timer 4 channel 0 compare mode 0 Compare disabled 1 Compare enabled
1:0	–	00	R/W	Reserved. Set to 00

### T4CC0 (0xED) – Timer 4 Channel 0 Compare Value

Bit	Name	Reset	R/W	Description
7:0	VAL [ 7 : 0 ]	0x00	R/W	Timer compare value channel 0

### T4CCTL1 (0xEE) – Timer 4 Channel 1 Compare Control

Bit	Name	Reset	R/W	Description
7	–	0	R0	Unused
6	IM	1	R/W	Channel 1 interrupt mask
5:3	CMP [ 2 : 0 ]	000	R/W	Channel 1 compare output mode select. Specified action on output when timer value equals compare value in T4CC1 000 Set output on compare 001 Clear output on compare 010 Toggle output on compare 011 Set output on compare-up, clear on 0 (clear on compare-down in up/down mode) 100 Clear output on compare-up, set on 0 (set on compare-down in up/down mode) 101 Set output on compare, clear on T4CC0 110 Clear output on compare, set on T4CC0 111 Not used
2	MODE	0	R/W	Mode. Select Timer 4 channel 1 compare mode 0 Compare disabled 1 Compare enabled
1:0	–	00	R/W	Reserved. Set to 00.

### T4CC1 (0xEF) – Timer 4 Channel 1 Compare Value

Bit	Name	Reset	R/W	Description
7:0	VAL [ 7 : 0 ]	0x00	R/W	Timer compare value channel 1

Peripherals : 8-bit timers, Timer 3 and Timer 4

**TIMIF (0xD8) – Timers 1/3/4 Interrupt Mask/Flag**

Bit	Name	Reset	R/W	Description
7	–	0	R0	Unused
6	OVFIM	1	R/W	Timer 1 overflow interrupt mask
5	T4CH1IF	0	R/W0	Timer 4 channel 1 interrupt flag 0 : no interrupt is pending 1 : interrupt is pending
4	T4CH0IF	0	R/W0	Timer 4 channel 0 interrupt flag 0 : no interrupt is pending 1 : interrupt is pending
3	T4OVFIF	0	R/W0	Timer 4 overflow interrupt flag 0 : no interrupt is pending 1 : interrupt is pending
2	T3CH1IF	0	R/W0	Timer 3 channel 1 interrupt flag 0 : no interrupt is pending 1 : interrupt is pending
1	T3CH0IF	0	R/W0	Timer 3 channel 0 interrupt flag 0 : no interrupt is pending 1 : interrupt is pending
0	T3OVFIF	0	R/W0	Timer 3 overflow interrupt flag 0 : no interrupt is pending 1 : interrupt is pending

### 13.9 Sleep Timer

The Sleep timer is used to set the period between when the system enters and exits low-power sleep modes.

The Sleep timer is also used to maintain timing in Timer 2 (MAC Timer) when entering a low-power sleep mode.

The main features of the Sleep timer are the following:

- 24-bit timer up-counter operating at 32kHz clock
- 24-bit compare
- Low-power mode operation in PM2
- Interrupt and DMA trigger

#### 13.9.1 Timer Operation

This section describes the operation of the timer.

##### 13.9.1.1 General

The Sleep timer is a 24-bit timer running on the 32kHz clock (either RC or XOSC). The timer starts running immediately after a reset

and continues to run uninterrupted. The current value of the timer can be read from the SFR registers  $ST2:ST1:ST0$ .

##### 13.9.1.2 Timer Compare

A timer compare occurs when the timer value is equal to the 24-bit compare value. The compare value is set by writing to the registers  $ST2:ST1:ST0$ . When a timer compare occurs the interrupt flag  $STIF$  is asserted.

used to wake up the device and return to active operation in PM0.

The default value of the compare value after reset is 0xFFFFFFFF. Note that before entering PM2 one should wait for  $ST0$  to change after setting new compare value.

The interrupt enable bit for the ST interrupt is  $IEN0.STIE$  and the interrupt flag is  $IRCON.STIF$ .

The Sleep timer compare can also be used as a DMA trigger (DMA trigger 11 in Table 41).

When operating in all power modes except PM3 the Sleep timer will be running. In PM1 and PM2 the Sleep timer compare event is

Note that if supply voltage drops below 2V while being in PM2, the sleep interval might be affected.

##### 13.9.1.3 Sleep Timer Registers

The registers used by the Sleep Timer are:

- $ST2$  – Sleep Timer 2
- $ST1$  – Sleep Timer 1
- $ST0$  – Sleep Timer 0

#### ST2 (0x97) – Sleep Timer 2

Bit	Name	Reset	R/W	Description
7:0	$ST2[7:0]$	0x00	R/W	Sleep timer count/compare value. When read, this register returns the high bits [23:16] of the sleep timer count. When writing this register sets the high bits [23:16] of the compare value. The value read is latched at the time of reading register $ST0$ . The value written is latched when $ST0$ is written.

#### ST1 (0x96) – Sleep Timer 1

Bit	Name	Reset	R/W	Description
7:0	$ST1[7:0]$	0x00	R/W	Sleep timer count/compare value. When read, this register returns the middle bits [15:8] of the sleep timer count. When writing this register sets the middle bits [15:8] of the compare value. The value read is latched at the time of reading register $ST0$ . The value written is latched when $ST0$ is written.

Peripherals : Sleep Timer

**ST0 (0x95) – Sleep Timer 0**

Bit	Name	Reset	R/W	Description
7:0	ST0[7:0]	0x00	R/W	Sleep timer count/compare value. When read, this register returns the low bits [7:0] of the sleep timer count. When writing this register sets the low bits [7:0] of the compare value.

### 13.10 ADC

#### 13.10.1 ADC Introduction

The ADC supports up to 12-bit analog-to-digital conversion. The ADC includes an analog multiplexer with up to eight individually configurable channels, reference voltage generator and conversion results written to memory through DMA. Several modes of operation are available.

The main features of the ADC are as follows:

- Selectable decimation rates which also sets the resolution (7 to 12 bits).

- Eight individual input channels, single-ended or differential
- Reference voltage selectable as internal, external single ended, external differential or AVDD\_SOC.
- Interrupt request generation
- DMA triggers at end of conversions
- Temperature sensor input
- Battery measurement capability

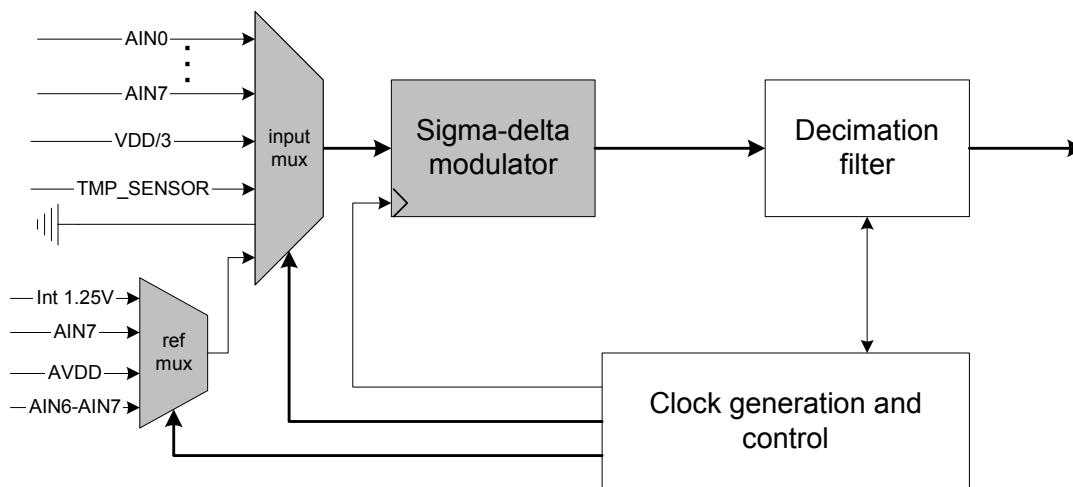

Figure 26: ADC block diagram.

#### 13.10.2 ADC Operation

This section describes the general setup and operation of the ADC and describes the usage

of the ADC control and status registers accessed by the CPU.

##### 13.10.2.1 ADC Core

The ADC includes an ADC capable of converting an analog input into a digital representation with up to 12 bits resolution.

The ADC uses a selectable positive reference voltage.

##### 13.10.2.2 ADC Inputs

The signals on the P0 port pins can be used as ADC inputs. In the following these port pin will be referred to as the AIN0-AIN7 pins. The input pins AIN0-AIN7 are connected to the ADC. The ADC can be set up to automatically perform a sequence of conversions and optionally perform an extra conversion from any channel when the sequence is completed.

supply can be applied to these pins, nor a supply larger than VDD (unregulated power). It is the difference between the pairs that are converted in differential mode.

It is possible to configure the inputs as single-ended or differential inputs. In the case where differential inputs are selected, the differential inputs consist of the input pairs AIN0-1, AIN2-3, AIN4-5 and AIN6-7. Note that no negative

In addition to the input pins AIN0-AIN7, the output of an on-chip temperature sensor can be selected as an input to the ADC for temperature measurements.

Peripherals : ADC

It is also possible to select a voltage corresponding to AVDD\_SOC/3 as an ADC input. This input allows the implementation of e.g. a battery monitor in applications where

**13.10.2.3 ADC conversion sequences**

The ADC can perform a sequence of conversions, and move the results to memory (through DMA) without any interaction from the CPU.

The conversion sequence can be influenced with the ADCCFG register (see section 13.4.6.6 on page 81) in that the eight analog inputs to the ADC comes from IO pins that are not necessarily programmed to be analog inputs. If a channel should normally be part of a sequence, but the corresponding analog input is disabled in the ADCCFG, then that channel will be skipped. For channels 8 to 12, both input pins must be enabled.

The ADCCON2.SCH register bits are used to define an ADC conversion sequence, from the ADC inputs. A conversion sequence will contain a conversion from each channel from 0 up to and including the channel number programmed in ADCCON2.SCH when ADCCON2.SCH is set to a value less than 8.

**13.10.2.4 ADC Operating Modes**

This section describes the operating modes and initialization of conversions.

The ADC has three control registers: ADCCON1, ADCCON2 and ADCCON3. These registers are used to configure the ADC and to report status.

The ADCCON1.EOC bit is a status bit that is set high when a conversion ends and cleared when ADCH is read.

The ADCCON1.ST bit is used to start a sequence of conversions. A sequence will start when this bit is set high, ADCCON1.STSEL is 11 and no conversion is currently running. When the sequence is completed, this bit is automatically cleared.

The ADCCON1.STSEL bits select which event that will start a new sequence of conversions. The options which can be selected are rising edge on external pin P2\_0, end of previous sequence, a Timer 1 channel 0 compare event or ADCCON1.ST is 1.

**13.10.2.5 ADC Conversion Results**

The digital conversion result is represented in two's complement form. For single ended configurations the result is always positive.

this feature is required. All these input configurations are controlled by the register ADCCON2.SCH

The single-ended inputs AIN0 to AIN7 are represented by channel numbers 0 to 7 in ADCCON2.SCH. Channel numbers 8 to 11 represent the differential inputs consisting of AIN0-AIN1, AIN2-AIN3, AIN4-AIN5 and AIN6-AIN7. Channel numbers 12 to 15 represent GND, internal voltage reference, temperature sensor and AVDD\_SOC/3, respectively.

When ADCCON2.SCH is set to a value between 8 and 12, the sequence will start at channel 8. For even higher settings, only single conversions are performed. In addition to this sequence of conversions, the ADC can be programmed to perform a single conversion from any channel as soon as the sequence has completed. This is called an extra conversion and is controlled with the ADCCON3 register.

The ADCCON2 register controls how the sequence of conversions is performed.

ADCCON2.SREF is used to select the reference voltage. The reference voltage should only be changed when no conversion is running.

The ADCCON2.SDIV bits select the decimation rate (and thereby also the resolution and time required to complete a conversion and sample rate). The decimation rate should only be changed when no conversion is running.

The last channel of a sequence is selected with the ADCCON2.SCH bits.

The ADCCON3 register controls the channel number, reference voltage and decimation rate for the extra conversion. The extra conversion will take place immediately after the ADCCON3 register is updated. The coding of the register bits is exactly as for ADCCON2.

This is because the result is the difference between ground and input signal which is always positively signed ( $V_{conv} = V_{inp} - V_{inn}$ ).

Peripherals : ADC

where  $V_{in} = 0V$ ). The maximum value is reached when the input amplitude is equal to  $V_{REF}$ , the selected voltage reference. For differential configurations the difference between two pin pairs are converted and this difference can be negatively signed. For 12-bit resolution the digital conversion result is 2047 when the analog input,  $V_{conv}$ , is equal to  $V_{REF}$ , and the conversion result is -2048 when the analog input is equal to  $-V_{REF}$ .

The digital conversion result is available in `ADCH` and `ADCL` when `ADCCON1.EOC` is set to

13.10.2.6 ADC Reference Voltage

The positive reference voltage for analog-to-digital conversions is selectable as either an internally generated 1.25V voltage, the `AVDD_SOC` pin, an external voltage applied to the `AIN7` input pin or a differential voltage applied to the `AIN6-AIN7` inputs.

13.10.2.7 ADC Conversion Timing

The ADC should be run when on the 32MHz system clock, which is divided by 8 to give a 4 MHz clock. Both the delta sigma modulator and decimation filter expect 4 MHz clock for their calculations. Using other frequencies will affect the results, and conversion time. All data presented within this data sheet are from 32MHz system clock usage.

The time required to perform a conversion depends on the selected decimation rate. When the decimation rate is set to for instance

13.10.2.8 ADC Interrupts

The ADC will generate an interrupt when an extra conversion has completed. An interrupt

13.10.2.9 ADC DMA Triggers

The ADC will generate a DMA trigger every time a conversion from the sequence has completed. When an extra conversion completes, no DMA trigger is generated.

There is one DMA trigger for each of the eight channels defined by the first eight possible settings for `ADCCON2.SCH`. The DMA trigger is active when a new sample is ready from the

13.10.2.10 ADC Registers

This section describes the ADC registers.

**ADCL (0xBA) – ADC Data Low**

Bit	Name	Reset	R/W	Description
7:2	<code>ADC[5:0]</code>	0x00	R	Least significant part of ADC conversion result.
1:0	-	00	R0	Not used. Always read as 0

1. Note that the conversion result always resides in MSB section of combined `ADCH` and `ADCL` registers.

When the `ADCCON2.SCH` bits are read, they will indicate the channel above the channel which the conversion result in `ADCL` and `ADCH` apply to. E.g. reading the value 0x1 from `ADCCON2.SCH`, means that the available conversion result is from input `AIN0`.

It is possible to select the reference voltage as the input to the ADC in order to perform a conversion of the reference voltage e.g. for calibration purposes. Similarly, it is possible to select the ground terminal `GND` as an input.

128, the decimation filter uses exactly 128 of the 4 MHz clock periods to calculate the result. When a conversion is started, the input multiplexer is allowed 16 4 MHz clock cycles to settle in case the channel has been changed since the previous conversion. The 16 clock cycles settling time applies to all decimation rates. Thus in general, the conversion time is given by:

$$T_{conv} = (\text{decimation rate} + 16) \times 0.25 \mu s.$$

is not generated when a conversion from the sequence is completed.

conversion for the channel. The DMA triggers are named `ADC_CHsd` in Table 41 on page 94, where *s* is single ended channel and *d* is differential channel.

In addition there is one DMA trigger, `ADC_CHALL`, which is active when new data is ready from any of the channels in the ADC conversion sequence.

Peripherals : ADC

### ADCH (0xBB) – ADC Data High

Bit	Name	Reset	R/W	Description
7:0	ADC[13:6]	0x00	R	Most significant part of ADC conversion result.

### ADCCON1 (0xB4) – ADC Control 1

Bit	Name	Reset	R/W	Description
7	EOC	0	R H0	End of conversion Cleared when ADCH has been read. If a new conversion is completed before the previous data has been read, the EOC bit will remain high. 0 conversion not complete 1 conversion completed
6	ST	0	R/W1	Start conversion. Read as 1 until conversion has completed 0 no conversion in progress 1 start a conversion sequence if ADCCON1.STSEL = 11 and no sequence is running.
5:4	STSEL[1:0]	11	R/W	Start select. Selects which event that will start a new conversion sequence. 00 External trigger on P2_0 pin. 01 Full speed. Do not wait for triggers. 10 Timer 1 channel 0 compare event 11 ADCCON1.ST = 1
3:2	RCTRL[1:0]	00	R/W	Controls the 16 bit random number generator. When written 01, the setting will automatically return to 00 when operation has completed. 00 Normal operation. (13x unrolling) 01 Clock the LFSR once (no unrolling). 10 Reserved 11 Stopped. Random number generator is turned off.
1:0	-	11	R/W	Reserved. Always set to 11.

## ADCCON2 (0xB5) – ADC Control 2

Bit	Name	Reset	R/W	Description
7:6	SREF[1:0]	00	R/W	<p>Selects reference voltage used for the sequence of conversions</p> <p>00 Internal 1.25V reference            01 External reference on AIN7 pin            10 AVDD_SOC pin            11 External reference on AIN6-AIN7 differential input</p>
5:4	SDIV[1:0]	01	R/W	<p>Sets the decimation rate for channels included in the sequence of conversions. The decimation rate also determines the resolution and time required to complete a conversion.</p> <p>00 64 decimation rate (7 bits resolution)            01 128 decimation rate (9 bits resolution)            10 256 decimation rate (10 bits resolution)            11 512 decimation rate (12 bits resolution)</p>
3:0	SCH[3:0]	0000	R/W	<p>Sequence Channel Select. Selects the end of the sequence. A sequence can either be from AIN0 to AIN7 (SCH&lt;=7) or from the differential input AIN0-AIN1 to AIN6-AIN7 (8&lt;=SCH&lt;=11). For other settings, only single conversions are performed.</p> <p>When read, these bits will indicate the channel number plus one of current conversion result.</p> <p>0000 AIN0            0001 AIN1            0010 AIN2            0011 AIN3            0100 AIN4            0101 AIN5            0110 AIN6            0111 AIN7            1000 AIN0-AIN1            1001 AIN2-AIN3            1010 AIN4-AIN5            1011 AIN6-AIN7            1100 GND            1101 Positive voltage reference            1110 Temperature sensor            1111 VDD/3</p>

Peripherals : ADC

**ADCCON3 (0xB6) – ADC Control 3**

Bit	Name	Reset	R/W	Description
7:6	EREF[1:0]	00	R/W	<p>Selects reference voltage used for the extra conversion</p> <p>00 Internal 1.25V reference            01 External reference on AIN7 pin            10 AVDD_SOC pin            11 External reference on AIN6-AIN7 differential input</p>
5:4	EDIV[1:0]	00	R/W	<p>Sets the decimation rate used for the extra conversion. The decimation rate also determines the resolution and time required to complete the conversion.</p> <p>00 64 dec rate (7 bits resolution)            01 128 dec rate (9 bits resolution)            10 256 dec rate (10 bits resolution)            11 512 dec rate (12 bits resolution)</p>
3:0	ECH[3:0]	0000	R/W	<p>Extra channel select. Selects the channel number of the extra conversion that is carried out after a conversion sequence has ended. This bit field must be written for an extra conversion to be performed. If the ADC is not running, writing to these bits will trigger an immediate single conversion from the selected extra channel. The bits are automatically cleared when the extra conversion has finished.</p> <p>0000 AIN0            0001 AIN1            0010 AIN2            0011 AIN3            0100 AIN4            0101 AIN5            0110 AIN6            0111 AIN7            1000 AIN0-AIN1            1001 AIN2-AIN3            1010 AIN4-AIN5            1011 AIN6-AIN7            1100 GND            1101 Positive voltage reference            1110 Temperature sensor            1111 VDD/3</p>

## 13.11 Random Number Generator

### 13.11.1 Introduction

The random number generator has the following features.

- Generate pseudo-random bytes which can be read by the CPU or used directly by the Command Strobe Processor (see section 14.34).
- Calculate CRC16 of bytes that are written to RNDH.
- Seeded by value written to RNDL.

The random number generator is a 16-bit Linear Feedback Shift Register (LFSR) with polynomial  $X^{16} + X^{15} + X^2 + 1$  (i.e. CRC16). It uses different levels of unrolling depending on the operation it performs. The basic version (no unrolling) is shown in Figure 27.

The random number generator is turned off when `ADCCON1.RCTRL = 11`.

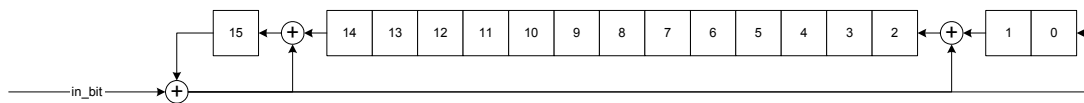

Figure 27: Basic structure of the Random Number Generator

### 13.11.2 Random Number Generator Operation

The operation of the random number generator is controlled by the `ADCCON1.RCTRL` bits. The current value of the

16-bit shift register in the LFSR can be read from the `RNDH` and `RNDL` registers.

#### 13.11.2.1 Semi random sequence generation

The default operation (`ADCCON1.RCTRL` is 00) is to clock the LFSR once (13x unrolling) each time the Command Strobe Processor reads the random value. This leads to the availability of a fresh pseudo-random byte from the LSB end of the LFSR.

Another way to update the LFSR is to set `ADCCON1.RCTRL` is 01. This will clock the LFSR once (no unrolling) and the `ADCCON1.RCTRL` bits will automatically be cleared when the operation has completed.

#### 13.11.2.2 Seeding

The LFSR can be seeded by writing to the `RNDL` register twice. Each time the `RNDL` register is written, the 8 LSB of the LFSR is copied to the 8 MSB and the 8 LSBs are replaced with the new data byte that was written to `RNDL`.

voltage regulator as described in section 15.1. The radio should be placed in infinite TX state, to avoid possible sync detect in RX state. The random values from the `IF_ADC` are read from the RF registers `ADCTSTH` and `ADCTSTL` (see page 196). The values read are used as the seed values to be written to the `RNDL` register as described above. Note that this can not be done while radio is in use for normal tasks.

When a true random value is required, the LFSR should be seeded by writing `RNDL` with random values from the `IF_ADC` in the RF receive path. To use this seeding method, the radio must first be powered on by enabling the

#### 13.11.2.3 CRC16

The LFSR can also be used to calculate the CRC value of a sequence of bytes. Writing to the `RNDH` register will trigger a CRC calculation. The new byte is processed from the MSB end and an 8x unrolling is used, so that a new byte can be written to `RNDH` every clock cycle.

Note that the LFSR must be properly seeded by writing to `RNDL`, before the CRC calculations start. Usually the seed value should be 0x0000 or 0xFFFF.

### 13.11.3 Random Number Generator Registers

This section describes the Random Number Generator registers.

#### RNDL (0xBC) – Random Number Generator Data Low Byte

Bit	Name	Reset	R/W	Description
[7:0]	RNDL [ 7 : 0 ]	0xFF	R/W	<p>Random value/seed or CRC result, low byte</p> <p>When used for random number generation writing this register twice will seed the random number generator. Writing to this register copies the 8 LSBs of the LFSR to the 8 MSBs and replaces the 8 LSBs with the data value written.</p> <p>The value returned when reading from this register is the 8 LSBs of the LSFR.</p> <p>When used for random number generation, reading this register returns the 8 LSBs of the random number. When used for CRC calculations, reading this register returns the 8 LSBs of the CRC result.</p>

#### RNDH (0xBD) – Random Number Generator Data High Byte

Bit	Name	Reset	R/W	Description
[7:0]	RNDH [ 7 : 0 ]	0xFF	R/W	<p>Random value or CRC result/input data, high byte</p> <p>When written, a CRC16 calculation will be triggered, and the data value written is processed starting with the MSB bit.</p> <p>The value returned when reading from this register is the 8 MSBs of the LSFR.</p> <p>When used for random number generation, reading this register returns the 8 MSBs of the random number. When used for CRC calculations, reading this register returns the 8 MSBs of the CRC result.</p>

### 13.12 AES Coprocessor

The **CC2430** data encryption is performed using a dedicated coprocessor which supports the Advanced Encryption Standard, AES. The coprocessor allows encryption/decryption to be performed with minimal CPU usage.

The coprocessor has the following features:

- Supports all security suites in IEEE 802.15.4
- ECB, CBC, CFB, OFB, CTR and CBC-MAC modes.
- Hardware support for CCM mode
- 128-bits key and IV/Nonce
- DMA transfer trigger capability

#### 13.12.1 AES Operation

To encrypt a message, the following procedure must be followed (ECB, CBC):

- Load key
- Load initialization vector (IV)
- Download and upload data for encryption/decryption.

The AES coprocessor works on blocks of 128 bits. A block of data is loaded into the coprocessor, encryption is performed and the result must be read out before the next block can be processed. Before each block load, a dedicated start command must be sent to the coprocessor.

#### 13.12.2 Key and IV

Before a key or IV/nonce load starts, an appropriate load key or IV/nonce command must be issued to the coprocessor. When loading the IV it is important to also set the correct mode.

A key load or IV load operation aborts any processing that could be running.

The key, once loaded, stays valid until a key reload takes place.

The IV must be downloaded before the beginning of each message (not block).

Both key and IV values are cleared by a reset of the device.

#### 13.12.3 Padding of input data

The AES coprocessor works on blocks of 128 bits. If the last block contains less than 128

bits, it must be padded with zeros when written to the coprocessor.

#### 13.12.4 Interface to CPU

The CPU communicates with the coprocessor using three SFR registers:

- ENCCS, Encryption control and status register
- ENCDI, Encryption input register
- ENCDO, Encryption output register

Read/write to the status register is done directly by the CPU, while access to the input/output registers should be performed using direct memory access (DMA).

When using DMA with AES coprocessor, two DMA channels must be used, one for input data and one for output data. The DMA channels must be initialized before a start command is written to the ENCCS. Writing a start command generates a DMA trigger and the transfer is started. After each block is processed, an interrupt is generated. The interrupt is used to issue a new start command to the ENCCS.

#### 13.12.5 Modes of operation

When using CFB, OFB and CTR mode, the 128 bits blocks are divided into four 32 bit blocks. 32 bits are loaded into the AES coprocessor and the resulting 32 bits are read out. This continues until all 128 bits have been encrypted. The only time one has to consider this is if data is loaded/read directly using the CPU. When using DMA, this is handled automatically by the DMA triggers generated

by the AES coprocessor, thus DMA is preferred.

Both encryption and decryption are performed similarly.

The CBC-MAC mode is a variant of the CBC mode. When performing CBC-MAC, data is downloaded to the coprocessor one 128 bits block at a time, except for the last block. Before the last block is loaded, the mode must

Peripherals : AES Coprocessor

be changed to CBC. The last block is then downloaded and the block uploaded will be the MAC value.

13.12.5.1 CBC-MAC

When performing CBC-MAC encryption, data is downloaded to the coprocessor in CBC-MAC mode one block at a time, except for the last block. Before the last block is loaded, the mode is changed to CBC. The last block is

13.12.5.2 CCM mode

To encrypt a message under CCM mode, the following sequence can be conducted (key is already loaded):

**Message Authentication Phase**

This phase takes place during steps 1-6 shown in the following.

CCM is a combination of CBC-MAC and CTR. Parts of the CCM must therefore be done in software. The following section gives a short explanation of the necessary steps to be done.

downloaded and the block uploaded is the message MAC.

CBC-MAC decryption is similar to encryption. The message MAC uploaded must be compared with the MAC to be verified.

- (1) The software loads the IV with zeros.
- (2) The software creates the block B0. The layout of block B0 is shown in Figure 28.

	Name B0				Designation First block for authentication in CCM mode											
Byte	0	1	2	3	4	5	6	7	8	9	10	11	12	13	14	15
Name	Flag	NONCE								L_M						

Figure 28: Message Authentication Phase Block 0

There is no restriction on the NONCE value. L\_M is the message length in bytes.

For 802.15.4 the NONCE is 13 bytes and L\_M is 2 bytes.

The content of the Authentication Flag byte is described in Figure 29.

L is set to 6 in this example. So, L-1 is set to 5. M and A\_Data can be set to any value.

	Name FLAG/B0		Designation Authentication Flag Field for CCM mode					
Bit	7	6	5	4	3	2	1	0
Name	Reserved	A_Data	(M-2)/2			L-1		
Value	0	x	x	x	x	1	0	1

Figure 29: Authentication Flag Byte

(3) If some Additional Authentication Data (denoted a below) is needed (that is A\_Data =1), the software creates the A\_Data length field, called L(a) by :

- (3a) If l(a)=0, (that is A\_Data =0), then L(a) is the empty string. Note that l(a) is the length of a in octets.
- (3b) If  $0 < l(a) < 2^{16} - 2^8$ , then L(a) is the 2-octets encoding of l(a).

The Additional Authentication Data is appended to the A\_Data length field L(a). The Additional Authentication Blocks is padded with zeros until the last Additional Authentication Block is full. There is no restriction on the length of a.

AUTH-DATA = L(a) + Authentication Data + (zero padding)

(4) The last block of the message is padded with zeros until full (that is if its length is not a multiple of 128 bits).

(5) The software concatenates the block B0, the Additional Authentication Blocks if any, and the message;

Input message = B0 + AUTH-DATA + Message + (zero padding of message)

(6) Once the input message authentication by CBC-MAC is finished, the software leaves the uploaded buffer contents unchanged (M=16), or keeps only the buffer's higher M bytes

Peripherals : AES Coprocessor

unchanged, while setting the lower bits to 0 ( $M \neq 16$ ).

The result is called T.

**Message Encryption**

(7) The software creates the key stream block A0. Note that  $L=6$ , with the current example of the CTR generation. The content is shown in Figure 30.

Note that when encrypting authentication data T to generate U in OFB mode, the CTR value

must be zero. When encrypting message blocks using CTR mode, CTR value must be any value but zero.

The content of the Encryption Flag byte is described in Figure 31.

	Name A0				Designation First CTR value for CCM mode											
Byte	0	1	2	3	4	5	6	7	8	9	10	11	12	13	14	15
Name	Flag	NONCE											CTR			

Figure 30: Message Encryption Phase Block

	Name FLAG/A0		Designation Encryption Flag Field for CCM mode					
Bit	7	6	5	4	3	2	1	0
Name	Reserved		-			L-1		
Value	0	0	0	0	0	1	0	1

Figure 31: Encryption Flag Byte

**Message Encryption (cont.)**

(8) The software loads A0 by selecting a Load IV/Nonce command. To do so, it sets Mode to CFB or OFB at the same time it selects the Load IV/Nonce command.

(9) The software calls a CFB or an OFB encryption on the authenticated data T. The uploaded buffer contents stay unchanged ( $M=16$ ), or only its first M bytes stay unchanged, the others being set to 0 ( $M-16$ ). The result is U, which will be used later.

(10) The software calls a CTR mode encryption right now on the still padded message blocks. It has to reload the IV when CTR value is any value but zero.

(11) The encrypted authentication data U is appended to the encrypted message. This gives the final result, c.

Result  $c = \text{encrypted message}(m) + U$

**Message Decryption**

CCM Mode decryption

In the coprocessor, the automatic generation of CTR works on 32 bits, therefore the maximum length of a message is  $128 \times 2^{32}$  bits, that is  $2^{36}$  bytes, which can be written in a

six-bit word. So, the value L is set to 6. To decrypt a CCM mode processed message, the following sequence can be conducted (key is already loaded):

**Message Parsing Phase**

(1) The software parses the message by separating the M rightmost octets, namely U, and the other octets, namely string C.

(2) C is padded with zeros until it can fill an integer number of 128-bit blocks;

(3) U is padded with zeros until it can fill a 128-bit block.

(4) The software creates the key stream block A0. It is done the same way as for CCM encryption.

(5) The software loads A0 by selecting a Load IV/Nonce command. To do so, it sets Mode to CFB or OFB at the same time as it selects the IV load.

(6) The software calls a CFB or an OFB encryption on the encrypted authenticated data U. The uploaded buffer contents stay unchanged ( $M=16$ ), or only its first M bytes stay unchanged, the others being set to 0 ( $M-16$ ). The result is T.

Peripherals : AES Coprocessor

(7) The software calls a CTR mode decryption right now on the encrypted message blocks C. It does not have to reload the IV/CTR.

**Reference Authentication tag generation**

This phase is identical to the Authentication Phase of CCM encryption. The only difference

is that the result is named MACTag (instead of T).

**Message Authentication checking Phase**

The software compares T with MACTag.

*13.12.6 Sharing the AES coprocessor between layers*

The AES coprocessor is a common resource shared by all layers. The AES coprocessor can only be used by one instance one at a time. It

is therefore necessary to implement some kind of software semaphore to allocate and de-allocate the resource.

*13.12.7 AES Interrupts*

The AES interrupt, ENC, is produced when encryption or decryption of a block is completed. The interrupt enable bit is IEN0.ENCIE and the interrupt flag is S0CON.ENCIF.

*13.12.8 AES DMA Triggers*

There are two DMA triggers associated with the AES coprocessor. These are ENC\_DW which is active when input data needs to be downloaded to the ENCDI register, and ENC\_UP which is active when output data needs to be uploaded from the ENCD0 register.

The ENCDI and ENCD0 registers should be set as destination and source locations for DMA channels used to transfer data to or from the AES coprocessor.

*13.12.9 AES Registers*

The AES coprocessor registers have the layout shown in this section.

## Peripherals : AES Coprocessor

**ENCCS (0xB3) – Encryption Control and Status**

Bit	Name	Reset	R/W	Description
7	–	0	R0	Not used, always read as 0
6:4	MODE[ 2 : 0 ]	000	R/W	Encryption/decryption mode 000 CBC 001 CFB 010 OFB 011 CTR 100 ECB 101 CBC MAC 110 Not used 111 Not used
3	RDY	1	R	Encryption/decryption ready status 0 Encryption/decryption in progress 1 Encryption/decryption is completed
2:1	CMD[ 1 : 0 ]	0	R/W	Command to be performed when a 1 is written to ST. 00 encrypt block 01 decrypt block 10 load key 11 load IV/nonce
0	ST	0	R/W1 H0	Start processing command set by CMD. Must be issued for each command or 128 bits block of data. Cleared by hardware

**ENCDI (0xB1) – Encryption Input Data**

Bit	Name	Reset	R/W	Description
7:0	DIN[ 7 : 0 ]	0x00	R/W	Encryption input data

**ENCDO (0xB2) – Encryption Output Data**

Bit	Name	Reset	R/W	Description
7:0	DOU[ 7 : 0 ]	0x00	R/W	Encryption output data

## 13.13 Watchdog Timer

The watchdog timer (WDT) is intended as a recovery method in situations where the CPU may be subjected to a software upset. The WDT shall reset the system when software fails to clear the WDT within a selected time interval. The watchdog can be used in applications that are subject to electrical noise, power glitches, electrostatic discharge etc., or where high reliability is required. If the watchdog function is not needed in an application, it is possible to configure the watchdog timer to be used as an interval timer that can be used to generate interrupts at selected time intervals.

The features of the watchdog timer are as follows:

- Four selectable timer intervals
- Watchdog mode
- Timer mode
- Interrupt request generation in timer mode
- Clock independent from system clock

The WDT is configured as either a watchdog timer or as a timer for general-purpose use. The operation of the WDT module is controlled by the `WDCTL` register. The watchdog timer consists of an 15-bit counter clocked by the 32.768 kHz clock. Note that the contents of the 15-bit counter is not user-accessible. The contents of the 15-bit counter is reset to 0x0000 when power modes PM2 or PM3 is entered.

### 13.13.1 Watchdog mode

The watchdog timer is disabled after a system reset. To set the WDT in watchdog mode the `WDCTL.MODE` bit is set to 0. The watchdog timer counter starts incrementing when the enable bit `WDCTL.EN` is set to 1. When the timer is enabled in watchdog mode it is not possible to disable the timer. Therefore, writing a 0 to `WDCTL.EN` has no effect if a 1 was already written to this bit when `WDCTL.MODE` was 0.

incrementing its value. The watchdog clear sequence consists of writing 0xA to `WDCTL.CLR[3:0]` followed by writing 0x5 to the same register bits within one half of a watchdog clock period. If this complete sequence is not performed, the watchdog timer generates a reset signal for the system. Note that as long as a correct watchdog clear sequence begins within the selected timer interval, the counter is reset when the complete sequence has been received.

The WDT operates with a watchdog timer clock frequency of 32.768 kHz. This clock frequency gives time-out periods equal to 1.9 ms, 15.625 ms, 0.25 s and 1 s corresponding to the count value settings 64, 512, 8192 and 32768 respectively.

When the watchdog timer has been enabled in watchdog mode, it is not possible to change the mode by writing to the `WDCTL.MODE` bit. The timer interval value can be changed by writing to the `WDCTL.INT[1:0]` bits.

If the counter reaches the selected timer interval value, the watchdog timer generates a reset signal for the system. If a watchdog clear sequence is performed before the counter reaches the selected timer interval value, the counter is reset to 0x0000 and continues

Note that it is recommended that user software clears the watchdog timer at the same time as the timer interval value is changed, in order to avoid an unwanted watchdog reset.

In watchdog mode, the WDT does not produce an interrupt request.

### 13.13.2 Timer mode

To set the WDT in normal timer mode, the `WDCTL.MODE` bit is set to 1. When register bit `WDCTL.EN` is set to 1, the timer is started and the counter starts incrementing. When the counter reaches the selected interval value, the timer will produce an interrupt request.

When the timer is cleared the contents of the counter is set to 0x0000. Writing a 0 to the enable bit `WDCTL.EN` stops the timer and writing 1 restarts the timer from 0x0000.

In timer mode, it is possible to clear the timer contents by writing a 1 to `WDCTL.CLR[0]`.

The timer interval is set by the `WDCTL.INT[1:0]` bits. In timer mode, a reset will not be produced when the timer interval has been reached.

### 13.13.3 Watchdog and Power Modes

In the two lowest power modes, PM2 and PM3, the watchdog is disabled and reset. After

wake up it will still be enabled and configured as it was prior to entering PM2/3 mode, but

Peripherals : Watchdog Timer

counting will start from zero. In PM1 the watchdog is still running, but it will not reset the chip while in PM1. This will not happen until it is woken up (it will wrap around and start over again when reset condition is reached). Also note that if the chip is woken in the watchdog timeout (reset condition) period the chip will be reset immediately. If woke up just prior to watchdog timeout the chip will be reset unless SW clears the watchdog

immediately after waking up from PM1. As the sleep timer and the watchdog run on the same clock the watchdog timeout interval can be aligned with sleep timer interval so SW can be made able to reset the watchdog. For external interrupt wakeups the max watchdog time out period should be used and the sleep timer set so SW can be activated to clear the watchdog periodically while waiting for external interrupt events.

13.13.4 Watchdog Timer Register

This section describes the register, WDCTL, for the Watchdog Timer.

**WDCTL (0xC9) – Watchdog Timer Control**

Bit	Name	Reset	R/W	Description
7:4	CLR[3:0]	0000	R/W	Clear timer. When 0xA followed by 0x5 is written to these bits, the timer is loaded with 0x0. Note the timer will only be cleared when 0x5 is written within 0.5 watchdog clock period after 0xA was written. Writing to these bits when EN is 0 have no effect.
3	EN	0	R/W	Enable timer. When a 1 is written to this bit the timer is enabled and starts incrementing. Writing a 0 to this bit in timer mode stops the timer. Writing a 0 to this bit in watchdog mode has no effect. 0 Timer disabled (stop timer) 1 Timer enabled
2	MODE	0	R/W	Mode select. This bit selects the watchdog timer mode. 0 Watchdog mode 1 Timer mode
1:0	INT[1:0]	00	R/W	Timer interval select. These bits select the timer interval defined as a given number of 32.768 kHz oscillator periods. 00 clock period x 32768 (typical 1 s) 01 clock period x 8192 (typical 0.25 s) 10 clock period x 512 (typical 15.625 ms) 11 clock period x 64 (typical 1.9 ms)

### 13.14 USART

USART0 and USART1 are serial communications interfaces that can be operated separately in either asynchronous UART mode or in synchronous SPI mode. The

two USARTs have identical function, and are assigned to separate I/O pins. Refer to section 13.1 for I/O configuration.

#### 13.14.1 UART mode

For asynchronous serial interfaces, the UART mode is provided. In the UART mode the interface uses a two-wire or four-wire interface consisting of the pins RXD, TXD and optionally RTS and CTS. The UART mode of operation includes the following features:

The UART mode provides full duplex asynchronous transfers, and the synchronization of bits in the receiver does not interfere with the transmit function. A UART byte transfer consists of a start bit, eight data bits, an optional ninth data or parity bit, and one or two stop bits. Note that the data transferred is referred to as a byte, although the data can actually consist of eight or nine bits.

- 8 or 9 data bits
- Odd, even or no parity
- Configurable start and stop bit level
- Configurable LSB or MSB first transfer
- Independent receive and transmit interrupts
- Independent receive and transmit DMA triggers
- Parity and framing error status

The UART operation is controlled by the USART Control and Status registers, `UxCSR` and the UART Control register `UxUCR` where `x` is the USART number, 0 or 1.

The UART mode is selected when `UxCSR.MODE` is set to 1.

##### 13.14.1.1 UART Transmit

A UART transmission is initiated when the USART Receive/transmit Data Buffer, `UxDBUF` register is written. The byte is transmitted on TXD<sub>x</sub> output pin. The `UxDBUF` register is double-buffered.

When the transmission ends, the `UxCSR.TX_BYTE` bit is set to 1. An interrupt request is generated when the `UxDBUF` register is ready to accept new transmit data. This happens immediately after the transmission has been started, hence a new data byte value can be loaded into the data buffer while the byte is being transmitted.

The `UxCSR.ACTIVE` bit goes high when the byte transmission starts and low when it ends.

##### 13.14.1.2 UART Receive

Data reception on the UART is initiated when a 1 is written to the `UxCSR.RE` bit. The UART will then search for a valid start bit on the RXD<sub>x</sub> input pin and set the `UxCSR.ACTIVE` bit high. When a valid start bit has been detected the received byte is shifted into the receive register. The `UxCSR.RX_BYTE` bit is set and a

receive interrupt is generated when the operation has completed. At the same time `UxCSR.ACTIVE` will go low.

The received data byte is available through the `UxDBUF` register. When `UxDBUF` is read, `UxCSR.RX_BYTE` is cleared by hardware.

##### 13.14.1.3 UART Hardware Flow Control

Hardware flow control is enabled when the `UxUCR.FLOW` bit is set to 1. The RTS output will then be driven low when the receive

register is empty and reception is enabled. Transmission of a byte will not occur before the CTS input go low.

##### 13.14.1.4 UART Character Format

If the `BIT9` and `PARITY` bits in register `UxUCR` are set high, parity generation and detection is enabled. The parity is computed and transmitted as the ninth bit, and during reception, the parity is computed and compared to the received ninth bit. If there is a parity error, the `UxCSR.ERR` bit is set high. This bit is cleared when `UxCSR` is read.

The number of stop bits to be transmitted is set to one or two bits determined by the register bit `UxUCR.SPB`. The receiver will always check for one stop bit. If the first stop bit received during reception is not at the expected stop bit level, a framing error is signaled by setting register bit `UxCSR.FE` high. `UxCSR.FE` is cleared when `UxCSR` is read.

Peripherals : USART

The receiver will check both stop bits when `UxUCR.SP_B` is set. Note that the RX interrupt will be set when first stop bit is checked OK. If second stop bit is not OK there will be a delay

13.14.2 SPI Mode

This section describes the SPI mode of operation for synchronous communication. In SPI mode, the USART communicates with an external system through a 3-wire or 4-wire interface. The interface consists of the pins MOSI, MISO, SCK and SS\_N. Refer to section 13.1 for description of how the USART pins are assigned to the I/O pins.

The SPI mode includes the following features:

13.14.2.1 SPI Master Operation

An SPI byte transfer in master mode is initiated when the `UxDBUF` register is written. The USART generates the SCK serial clock using the baud rate generator (see section 13.14.4) and shifts the provided byte from the transmit register onto the MOSI output. At the same time the receive register shifts in the received byte from the MISO input pin.

The `UxCSR.ACTIVE` bit goes high when the transfer starts and low when the transfer ends. When the transfer ends, the `UxCSR.TX_BYTE` bit is set to 1.

The polarity and clock phase of the serial clock SCK is selected by `UxGCR.CPOL` and `UxGCR.CPHA`. The order of the byte transfer is selected by the `UxGCR.ORDER` bit.

At the end of the transfer, the received data byte is available for reading from the `UxDBUF`. A receive interrupt is generated when this new data is ready in the `UxDBUF` USART Receive/Transmit Data register.

A transmit interrupt is generated when the unit is ready to accept another data byte for transmission. Since `UxDBUF` is double-buffered, this happens just after the

13.14.2.2 SPI Slave Operation

An SPI byte transfer in slave mode is controlled by the external system. The data on the MOSI input is shifted into the receive register controlled by the serial clock SCK which is an input in slave mode. At the same time the byte in the transmit register is shifted out onto the MISO output.

The `UxCSR.ACTIVE` bit goes high when the transfer starts and low when the transfer ends.

in when the framing error bit, `UxCSR.FE`, is set. This delay is baud rate dependable (bit duration).

- 3-wire (master) and 4-wire SPI interface
- Master and slave modes
- Configurable SCK polarity and phase
- Configurable LSB or MSB first transfer

The SPI mode is selected when `UxCSR.MODE` is set to 0.

In SPI mode, the USART can be configured to operate either as an SPI master or as an SPI slave by writing the `UxCSR.SLAVE` bit.

transmission has been initiated. Note that data should not be written to `UxDBUF` until `UxCSR.TX_BYTE` is 1. For DMA transfers this is handled automatically. For back-to-back transmits using DMA the `UxGDR.CPHA` bit must be set to zero, if not transmitted bytes can become corrupted. For systems requiring setting of `UxGDR.CPHA`, polling `UxCSR.TX_BYTE` is needed.

Also note the difference between transmit interrupt and receive interrupt as the former arrives approximately 8 bit periods prior to the latter.

SPI master mode operation as described above is a 3-wire interface. No select input is used to enable the master. If the external slave requires a slave select signal this can be implemented through software using a general-purpose I/O pin.

Then the `UxCSR.RX_BYTE` bit is set and a receive interrupt is generated.

The expected polarity and clock phase of SCK is selected by `UxGCR.CPOL` and `UxGDR.CPHA`. The expected order of the byte transfer is selected by the `UxGCR.ORDER` bit.

Peripherals : USART

At the end of the transfer, the received data byte is available for reading from UxDBUF

The transmit interrupt is generated at the start of the operation.

13.14.3 SSN Slave Select Pin

When the USART is operating in SPI mode, configured as an SPI slave, a 4-wire interface is used with the Slave Select (SSN) pin as an input to the SPI (edge controlled). At falling edge of SSN the SPI slave is active and receives data on the MOSI input and outputs data on the MISO output. At rising edge of SSN, the SPI slave is inactive and will not receive data. Note that the MISO output is not tri-stated after rising edge on SSn. Also note that release of SSn (rising edge) must be aligned to end of byte received or sent. If

released in a byte the next received byte will not be received properly as information about previous byte is present in SPI system. A USART flush can be used to remove this information.

In SPI master mode, the SSN pin is not used. When the USART operates as an SPI master and a slave select signal is needed by an external SPI slave device, then a general purpose I/O pin should be used to implement the slave select signal function in software.

13.14.4 Baud Rate Generation

An internal baud rate generator sets the UART baud rate when operating in UART mode and the SPI master clock frequency when operating in SPI mode.

The maximum baud rate for UART mode is F/16 when BAUD\_E is 16 and BAUD\_M is 0, and where F is the system clock frequency.

The UxBAUD.BAUD\_M[7:0] and UxGCR.BAUD\_E[4:0] registers define the baud rate used for UART transfers and the rate of the serial clock for SPI transfers. The baud rate is given by the following equation:

The maximum baud rate for SPI master mode and thus SCK frequency is F/8. This is set when BAUD\_E is 17 and BAUD\_M is 0. If SPI master mode does not need to receive data the maximum SPI rate is F/2 where BAUD\_E is 19 and BAUD\_M is 0. Setting higher baud rates than this will give erroneous results. For SPI slave mode the maximum baud rate is always F/8.

$$Baudrate = \frac{(256 + BAUD\_M) * 2^{BAUD\_E}}{2^{28}} * F$$

where F is the system clock frequency, 16 MHz (calibrated RC osc.) or 32 MHz (crystal osc.).

Note that the baud rate must be set through the UxBAUD and registers UxGCR before any other UART or SPI operations take place. This means that the timer using this information is not updated until it has completed its start conditions, thus changing the baud rate take time.

The register values required for standard baud rates are shown in Table 43 for a typical system clock set to 32 MHz. The table also gives the difference in actual baud rate to standard baud rate value as a percentage error.

Table 43: Commonly used baud rate settings for 32 MHz system clock

Baud rate (bps)	UxBAUD.BAUD_M	UxGCR.BAUD_E	Error (%)
2400	59	6	0.14
4800	59	7	0.14
9600	59	8	0.14
14400	216	8	0.03
19200	59	9	0.14
28800	216	9	0.03
38400	59	10	0.14
57600	216	10	0.03
76800	59	11	0.14
115200	216	11	0.03
230400	216	12	0.03

### 13.14.5 USART flushing

The current operation can be aborted by setting the `UxUCR.FLUSH` register bit. This event will stop the current operation and clear all data buffers. It should be noted that setting the flush bit in the middle of a TX/RX bit, the flushing will not take place until this bit has ended (buffers will be cleared immediately but

timer keeping knowledge of bit duration will not). Thus using the flush bit should either be aligned with USART interrupts or use a wait time of one bit duration at current baud rate before updated data or configuration can be received by the USART.

### 13.14.6 USART Interrupts

Each USART has two interrupts. These are the RX complete interrupt (URXx) and the TX complete interrupt (UTXx).

The USART interrupt enable bits are found in the `IEN0` and `IEN2` registers. The interrupt flags are located in the `TCON` and `IRCON2` registers. Refer to section 11.5 on page 49 for details of these registers. The interrupt enables and flags are summarized below.

Interrupt enables:

- USART0 RX : `IEN0.URX0IE`
- USART1 RX : `IEN0.URX1IE`
- USART0 TX : `IEN2.UTX0IE`
- USART1 TX : `IEN2.UTX1IE`

Interrupt flags:

- USART0 RX : `TCON.URX0IF`
- USART1 RX : `TCON.URX1IF`
- USART0 TX : `IRCON2.UTX0IF`
- USART1 TX : `IRCON2.UTX1IF`

### 13.14.7 USART DMA Triggers

There are two DMA triggers associated with each USART. The DMA triggers are activated by RX complete and TX complete events i.e. the same events as the USART interrupt requests. A DMA channel can be configured

using a USART Receive/transmit buffer, `UxDBUF`, as source or destination address.

Refer to Table 41 on page 94 for an overview of the DMA triggers.

### 13.14.8 USART Registers

The registers for the USART are described in this section. For each USART there are five registers consisting of the following (x refers to USART number i.e. 0 or 1):

- `UxCSR` USART x Control and Status
- `UxUCR` USART x UART Control
- `UxGCR` USART x Generic Control
- `UxDBUF` USART x Receive/Transmit data buffer
- `UxBAUD` USART x Baud Rate Control

Peripherals : USART

**U0CSR (0x86) – USART 0 Control and Status**

Bit	Name	Reset	R/W	Description
7	MODE	0	R/W	USART mode select 0 SPI mode 1 UART mode
6	RE	0	R/W	UART receiver enable 0 Receiver disabled 1 Receiver enabled
5	SLAVE	0	R/W	SPI master or slave mode select 0 SPI master 1 SPI slave
4	FE	0	R/W0	UART framing error status 0 No framing error detected 1 Byte received with incorrect stop bit level
3	ERR	0	R/W0	UART parity error status 0 No parity error detected 1 Byte received with parity error
2	RX_BYTE	0	R/W0	Receive byte status. UART mode and SPI slave mode 0 No byte received 1 Received byte ready
1	TX_BYTE	0	R/W0	Transmit byte status. UART mode and SPI master mode 0 Byte not transmitted 1 Last byte written to Data Buffer register transmitted
0	ACTIVE	0	R	USART transmit/receive active status 0 USART idle 1 USART busy in transmit or receive mode

## Peripherals : USART

**U0UCR (0xC4) – USART 0 UART Control**

Bit	Name	Reset	R/W	Description
7	FLUSH	0	R0/W1	Flush unit. When set, this event will stop the current operation and return the unit to idle state.
6	FLOW	0	R/W	UART hardware flow enable. Selects use of hardware flow control with RTS and CTS pins 0 Flow control disabled 1 Flow control enabled
5	D9	0	R/W	UART data bit 9 contents. This value is used when 9 bit transfer is enabled. When parity is disabled, the value written to D9 is transmitted as the bit 9 when 9 bit data is enabled.  If parity is enabled then this bit sets the parity level as follows. 0 Even parity 1 Odd parity
4	BIT9	0	R/W	UART 9-bit data enable. When this bit is 1, data is 9 bits and the content of data bit 9 is given by D9 and PARITY. 0 8 bits transfer 1 9 bits transfer
3	PARITY	0	R/W	UART parity enable. 0 Parity disabled 1 Parity enabled
2	SPB	0	R/W	UART number of stop bits. Selects the number of stop bits to transmit 0 1 stop bit 1 2 stop bits
1	STOP	1	R/W	UART stop bit level 0 Low stop bit 1 High stop bit
0	START	0	R/W	UART start bit level. The polarity of the idle line is assumed the opposite of the selected start bit level. 0 Low start bit 1 High start bit

Peripherals : USART

### U0GCR (0xC5) – USART 0 Generic Control

Bit	Name	Reset	R/W	Description
7	CPOL	0	R/W	SPI clock polarity 0 Negative clock polarity 1 Positive clock polarity
6	CPHA	0	R/W	SPI clock phase 0 Data is output on <i>MOSI</i> when <i>SCK</i> goes from <b>CPOL</b> inverted to <b>CPOL</b> , and data input is sampled on <i>MISO</i> when <i>SCK</i> goes from <b>CPOL</b> to <b>CPOL</b> inverted. 1 Data is output on <i>MOSI</i> when <i>SCK</i> goes from <b>CPOL</b> to <b>CPOL</b> inverted, and data input is sampled on <i>MISO</i> when <i>SCK</i> goes from <b>CPOL</b> inverted to <b>CPOL</b> .
5	ORDER	0	R/W	Bit order for transfers 0 LSB first 1 MSB first
4:0	BAUD_E [ 4 : 0 ]	0x00	R/W	Baud rate exponent value. <b>BAUD_E</b> along with <b>BAUD_M</b> decides the UART baud rate and the SPI master SCK clock frequency

### U0DBUF (0xC1) – USART 0 Receive/Transmit Data Buffer

Bit	Name	Reset	R/W	Description
7:0	DATA [ 7 : 0 ]	0x00	R/W	USART receive and transmit data. When writing this register the data written is written to the internal, transmit data register. When reading this register, the data from the internal read data register is read.

### U0BAUD (0xC2) – USART 0 Baud Rate Control

Bit	Name	Reset	R/W	Description
7:0	BAUD_M [ 7 : 0 ]	0x00	R/W	Baud rate mantissa value. <b>BAUD_E</b> along with <b>BAUD_M</b> decides the UART baud rate and the SPI master SCK clock frequency

## Peripherals : USART

**U1CSR (0xF8) – USART 1 Control and Status**

Bit	Name	Reset	R/W	Description
7	MODE	0	R/W	USART mode select 0 SPI mode 1 UART mode
6	RE	0	R/W	UART receiver enable 0 Receiver disabled 1 Receiver enabled
5	SLAVE	0	R/W	SPI master or slave mode select 0 SPI master 1 SPI slave
4	FE	0	R/W0	UART framing error status 0 No framing error detected 1 Byte received with incorrect stop bit level
3	ERR	0	R/W0	UART parity error status 0 No parity error detected 1 Byte received with parity error
2	RX_BYTE	0	R/W0	Receive byte status. UART mode and SPI slave mode 0 No byte received 1 Received byte ready
1	TX_BYTE	0	R/W0	Transmit byte status. UART mode and SPI master mode 0 Byte not transmitted 1 Last byte written to Data Buffer register transmitted
0	ACTIVE	0	R	USART transmit/receive active status 0 USART idle 1 USART busy in transmit or receive mode

Peripherals : USART

**U1UCR (0xFB) – USART 1 UART Control**

Bit	Name	Reset	R/W	Description
7	FLUSH	0	R0/W1	Flush unit. When set, this event will immediately stop the current operation and return the unit to idle state.
6	FLOW	0	R/W	UART hardware flow enable. Selects use of hardware flow control with RTS and CTS pins 0 Flow control disabled 1 Flow control enabled
5	D9	0	R/W	UART data bit 9 contents. This value is used 9 bit transfer is enabled. When parity is disabled, the value written to D9 is transmitted as the bit 9 when 9 bit data is enabled.  If parity is enabled then this bit sets the parity level as follows. 0 Even parity 1 Odd parity
4	BIT9	0	R/W	UART 9-bit data enable. When this bit is 1, data is 9 bits and the content of data bit 9 is given by D9 and PARITY. 0 8 bits transfer 1 9 bits transfer
3	PARITY	0	R/W	UART parity enable. 0 Parity disabled 1 Parity enabled
2	SPB	0	R/W	UART number of stop bits. Selects the number of stop bits to transmit 0 1 stop bit 1 2 stop bits
1	STOP	1	R/W	UART stop bit level 0 Low stop bit 1 High stop bit
0	START	0	R/W	UART start bit level. The polarity of the idle line is assumed the opposite of the selected start bit level. 0 Low start bit 1 High start bit

Peripherals : USART

### U1GCR (0xFC) – USART 1 Generic Control

Bit	Name	Reset	R/W	Description
7	CPOL	0	R/W	SPI clock polarity 0 Negative clock polarity 1 Positive clock polarity
6	CPHA	0	R/W	SPI clock phase 0 Data is output on <i>MOSI</i> when <i>SCK</i> goes from <b>CPOL</b> inverted to <b>CPOL</b> , and data input is sampled on <i>MISO</i> when <i>SCK</i> goes from <b>CPOL</b> to <b>CPOL</b> inverted. 1 Data is output on <i>MOSI</i> when <i>SCK</i> goes from <b>CPOL</b> to <b>CPOL</b> inverted, and data input is sampled on <i>MISO</i> when <i>SCK</i> goes from <b>CPOL</b> inverted to <b>CPOL</b> .
5	ORDER	0	R/W	Bit order for transfers 0 LSB first 1 MSB first
4:0	BAUD_E [ 4 : 0 ]	0x00	R/W	Baud rate exponent value. <b>BAUD_E</b> along with <b>BAUD_M</b> decides the UART baud rate and the SPI master SCK clock frequency

### U1DBUF (0xF9) – USART 1 Receive/Transmit Data Buffer

Bit	Name	Reset	R/W	Description
7:0	DATA [ 7 : 0 ]	0x00	R/W	USART receive and transmit data. When writing this register the data written is written to the internal, transmit data register. When reading this register, the data from the internal read data register is read.

### U1BAUD (0xFA) – USART 1 Baud Rate Control

Bit	Name	Reset	R/W	Description
7:0	BAUD_M [ 7 : 0 ]	0x00	R/W	Baud rate mantissa value. <b>BAUD_E</b> along with <b>BAUD_M</b> decides the UART baud rate and the SPI master SCK clock frequency

14 Radio

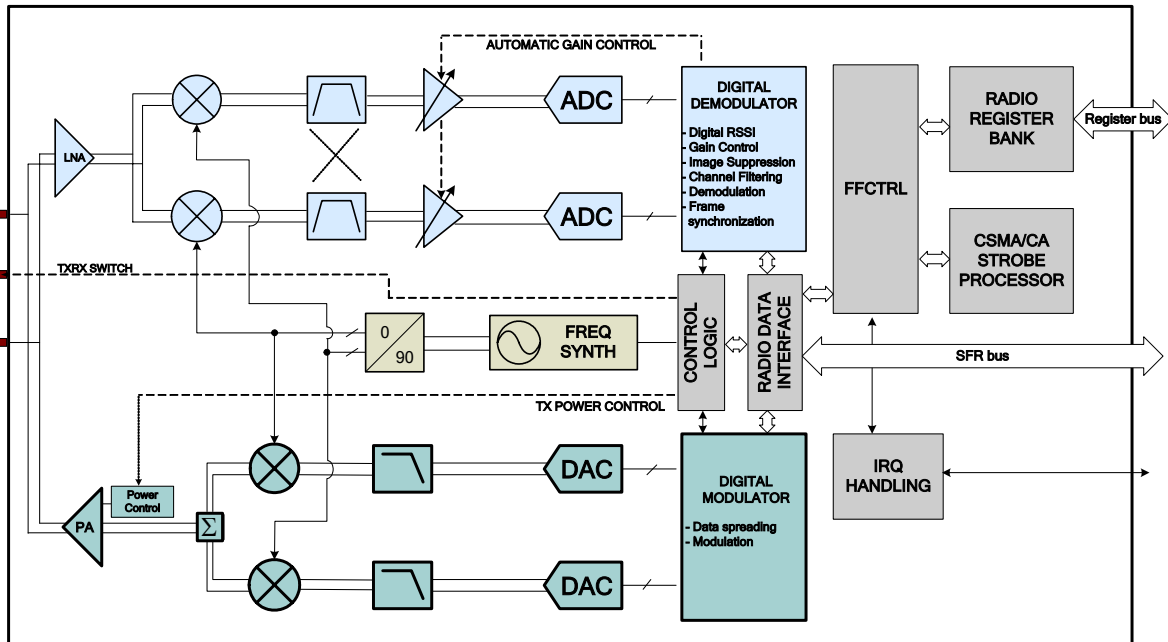

Figure 32: CC2430 Radio Module

A simplified block diagram of the IEEE 802.15.4 compliant radio inside **CC2430** is shown in Figure 32. The radio core is based on the industry leading **CC2420** RF transceiver.

**CC2430** features a low-IF receiver. The received RF signal is amplified by the low-noise amplifier (LNA) and down-converted in quadrature (I and Q) to the intermediate frequency (IF). At IF (2 MHz), the complex I/Q signal is filtered and amplified, and then digitized by the RF receiver ADCs. Automatic gain control, final channel filtering, de-spreading, symbol correlation and byte synchronization are performed digitally.

An interrupt indicates that a start of frame delimiter has been detected. **CC2430** buffers the received data in a 128 byte receive FIFO. The user may read the FIFO through an SFR interface. It is recommended to use direct memory access (DMA) to move data between memory and the FIFO.

CRC is verified in hardware. RSSI and correlation values are appended to the frame. Clear channel assessment, CCA, is available through an interrupt in receive mode.

The **CC2430** transmitter is based on direct up-conversion. The data is buffered in a 128 byte transmit FIFO (separate from the receive FIFO). The preamble and start of frame delimiter are generated in hardware. Each

symbol (4 bits) is spread using the IEEE 802.15.4 spreading sequence to 32 chips and output to the digital-to-analog converters (DACs).

An analog low pass filter passes the signal to the quadrature (I and Q) up-conversion mixers. The RF signal is amplified in the power amplifier (PA) and fed to the antenna.

The internal T/R switch circuitry makes the antenna interface and matching easy. The RF connection is differential. A balun may be used for single-ended antennas. The biasing of the PA and LNA is done by connecting TXRX\_SWITCH to RF\_P and RF\_N through an external DC path.

The frequency synthesizer includes a completely on-chip LC VCO and a 90 degrees phase splitter for generating the I and Q LO signals to the down-conversion mixers in receive mode and up-conversion mixers in transmit mode. The VCO operates in the frequency range 4800 – 4966 MHz, and the frequency is divided by two when split into I and Q signals.

The digital baseband includes support for frame handling, address recognition, data buffering, CSMA-CA strobe processor and MAC security.

An on-chip voltage regulator delivers the regulated 1.8 V supply voltage.

14.1 IEEE 802.15.4 Modulation Format

This section is meant as an introduction to the 2.4 GHz direct sequence spread spectrum (DSSS) RF modulation format defined in IEEE 802.15.4. For a complete description, please refer to [1].

The modulation and spreading functions are illustrated at block level in Figure 33 [1]. Each byte is divided into two symbols, 4 bits each. The least significant symbol is transmitted first.

For multi-byte fields, the least significant byte is transmitted first.

Each symbol is mapped to one out of 16 pseudo-random sequences, 32 chips each. The symbol to chip mapping is shown in Table 44. The chip sequence is then transmitted at 2 MChips/s, with the least significant chip ( $C_0$ ) transmitted first for each symbol.

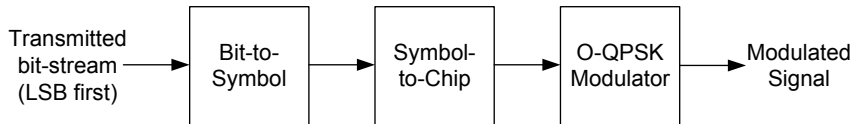

Figure 33: Modulation and spreading functions [1]

The modulation format is Offset – Quadrature Phase Shift Keying (O-QPSK) with half-sine chip shaping. This is equivalent to MSK modulation. Each chip is shaped as a half-

sine, transmitted alternately in the I and Q channels with one half chip period offset. This is illustrated for the zero-symbol in Figure 34.

Table 44: IEEE 802.15.4 symbol-to-chip mapping [1]

Symbol	Chip sequence ( $C_0, C_1, C_2, \dots, C_{31}$ )
0	1 1 0 1 1 0 0 1 1 1 1 0 0 0 0 1 1 0 1 0 1 0 1 0 0 1 0 0 0 1 0 1 1 1 0
1	1 1 1 0 1 1 0 1 1 0 0 1 1 1 1 0 0 0 0 1 1 0 1 0 1 0 0 1 0 0 0 1 0
2	0 0 1 0 1 1 1 1 0 1 1 0 1 1 0 0 1 1 1 0 0 0 0 1 1 0 1 0 1 0 0 1 0
3	0 0 1 0 0 0 1 0 1 1 1 0 1 1 0 1 1 0 0 1 1 1 0 0 0 0 1 1 0 1 0 1
4	0 1 0 1 0 0 1 0 0 0 1 0 1 1 1 0 1 1 0 1 1 0 0 1 1 1 0 0 0 0 1 1
5	0 0 1 1 0 1 0 1 0 0 1 0 0 0 1 0 1 1 1 0 1 1 0 1 1 0 0 1 1 1 0 0
6	1 1 0 0 0 0 1 1 0 1 0 1 0 0 1 0 0 0 1 0 1 1 1 0 1 1 0 1 1 0 0 1
7	1 0 0 1 1 1 0 0 0 0 1 1 0 1 0 1 0 0 1 0 0 0 1 0 1 1 1 0 1 1 0 1
8	1 0 0 0 1 1 0 0 1 0 0 1 0 1 1 0 0 0 0 0 0 1 1 1 0 1 1 1 1 0 1 1
9	1 0 1 1 1 0 0 0 1 1 0 0 1 0 0 1 0 1 1 0 0 0 0 0 0 1 1 1 0 1 1 1
10	0 1 1 1 1 0 1 1 1 1 0 0 0 1 1 0 0 1 0 0 1 0 1 1 0 0 0 0 0 0 1 1 1
11	0 1 1 1 0 1 1 1 1 0 1 1 1 0 0 0 1 1 0 0 1 0 0 1 0 1 1 0 0 0 0 0
12	0 0 0 0 0 1 1 1 0 1 1 1 1 0 1 1 1 0 0 0 1 1 0 0 1 0 0 1 0 1 1 0
13	0 1 1 0 0 0 0 0 0 1 1 1 0 1 1 1 1 0 1 1 1 0 0 0 1 1 0 0 1 0 0 1
14	1 0 0 1 0 1 1 0 0 0 0 0 0 1 1 1 0 1 1 1 1 0 1 1 1 0 0 0 1 1 0 0
15	1 1 0 0 1 0 0 1 0 1 1 0 0 0 0 0 0 1 1 1 0 1 1 1 1 0 1 1 1 0 0 0

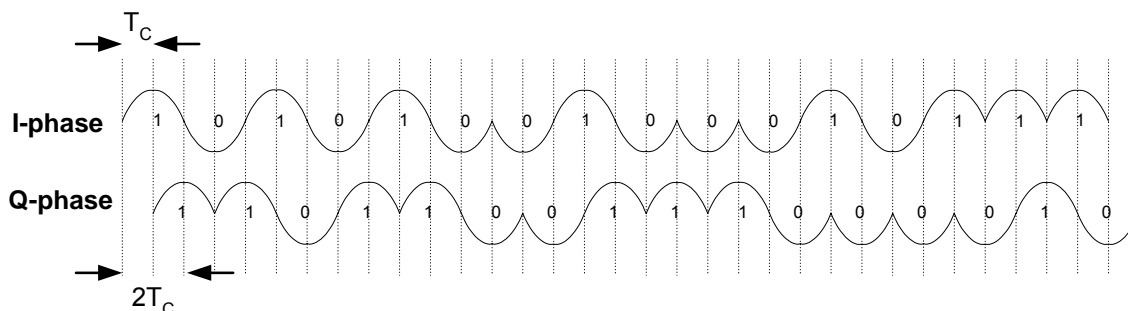

Figure 34: I / Q Phases when transmitting a zero-symbol chip sequence,  $T_c = 0.5 \mu s$

## 14.2 Command strobos

The CPU uses a set of *command strobos* to control operation of the radio in **CC2430**.

Command strobos may be viewed as single byte instructions which each control some function of the radio. These command strobos must be used to enable the frequency synthesizer, enable receive mode, enable transmit mode and other functions.

A total of nine command strobos are defined for the radio and these can be written

individually to the radio or they can be given in a sequence together with a set of dedicated software instructions making up a simple program. All command strobos from the CPU to the radio pass through the CSMA-CA/Command Strobe Processor (CSP). Detailed description about the CSP and how command strobos are used is given in section 14.34 on page 176.

## 14.3 RF Registers

The operation of the radio is configured through a set of RF registers. These RF registers are mapped to XDATA memory space as shown in Figure 7 on page 31.

The RF registers also provide status information from the radio.

The RF registers control/status bits are referred to where appropriate in the following sections while section 14.35 on page 183 gives a full description of all RF registers.

## 14.4 Interrupts

The radio is associated with two interrupt vectors on the CPU. These are the RFERR interrupt (interrupt 0) and the RF interrupt (interrupt 12) with the following functions

- RFERR : TXFIFO underflow, RXFIFO overflow
- RF : all other RF interrupts given by RFIF interrupt flags

The RF interrupt vector combines the interrupts in RFIF shown on page 156. Note that these RF interrupts are rising-edge triggered. Thus an interrupt is generated when e.g. the SFD status flag goes from 0 to 1.

The RFIF interrupt flags are described in the next section.

### 14.4.1 Interrupt registers

Two of the main interrupt control SFR registers are used to enable the RF and RFERR interrupts. These are the following:

- RFERR : IEN0.RFERRIE
- RF : IEN2.RFIE

Two main interrupt flag SFR registers hold the RF and RFERR interrupt flags. These are the following:

- RFERR : TCON.RFERRIF
- RF : S1CON.RFIF

Refer to section 11.5 on page 49 for details about the interrupts.

The RF interrupt is the combined interrupt from eight different sources in the radio. Two SFR registers are used for setting the eight individual RFIF radio interrupt flags and interrupt enables. These are the RFIF and RFIM registers.

Radio : Interrupts

The interrupt flags in SFR register `RFIF` show the status for each interrupt source for the RF interrupt vector.

The interrupt enable bits in `RFIM` are used to disable individual interrupt sources for the RF interrupt vector. Note that masking an interrupt source in `RFIM` does not affect the update of the status in the `RFIF` register.

Due to the use of the individual interrupt masks in `RFIM`, and the main interrupt mask for the RF interrupt given by `IEN2.RFIE` there is two-layered masking of this interrupt. Special attention needs to be taken when

processing this type of interrupt as described below.

To clear the RF interrupt, `S1CON.RFIF` and the interrupt flag in `RFIF` need to be cleared. If more than one interrupt source generates an interrupt the source that was not cleared will generate another interrupt after completing the interrupt service routine (ISR). A `RFIF` flag that was set and was not cleared during ISR will create another interrupt when ISR completed. If no individual knowledge of which interrupt caused the ISR to be called, all `RFIF` flags should be cleared.

**RFIF (0xE9) – RF Interrupt Flags**

Bit	Name	Reset	R/W	Description
7	<code>IRQ_RREG_ON</code>	0	R/W0	Voltage regulator for radio has been turned on 0 No interrupt pending 1 Interrupt pending
6	<code>IRQ_TXDONE</code>	0	R/W0	TX completed with packet sent. Also set for acknowledge frames if RF register <code>IRQSRC.TXACK</code> is 1 0 No interrupt pending 1 Interrupt pending
5	<code>IRQ_FIFOP</code>	0	R/W0	Number of bytes in <code>RXFIFO</code> is above threshold set by <code>IOCFG0.FIFOP_THR</code> 0 No interrupt pending 1 Interrupt pending
4	<code>IRQ_SFD</code>	0	R/W0	Start of frame delimiter (SFD) has been detected 0 No interrupt pending 1 Interrupt pending
3	<code>IRQ_CCA</code>	0	R/W0	Clear channel assessment (CCA) indicates that channel is clear 0 No interrupt pending 1 Interrupt pending
2	<code>IRQ_CSP_WT</code>	0	R/W0	CSMA-CA/strobe processor (CSP) wait condition is true 0 No interrupt pending 1 Interrupt pending
1	<code>IRQ_CSP_STOP</code>	0	R/W0	CSMA-CA/strobe processor (CSP) program execution stopped 0 No interrupt pending 1 Interrupt pending
0	<code>IRQ_CSP_INT</code>	0	R/W0	CSMA-CA/strobe processor (CSP) INT instruction executed 0 No interrupt pending 1 Interrupt pending

Radio : FIFO access

**RFIM (0x91) – RF Interrupt Mask**

Bit	Name	Reset	R/W	Description
7	IM_RREG_PD	0	R/W	Voltage regulator for radio has been turned on 0 Interrupt disabled 1 Interrupt enabled
6	IM_TXDONE	0	R/W	TX completed with packet sent. Also for acknowledge frames if RF register IRQSRC.TXACK is 1 0 Interrupt disabled 1 Interrupt enabled
5	IM_FIFOP	0	R/W	Number of bytes in RXFIFO is above threshold set by IOCFG0.FIFOP_THR 0 Interrupt disabled 1 Interrupt enabled
4	IM_SFD	0	R/W	Start of frame delimiter (SFD) has been detected 0 Interrupt disabled 1 Interrupt enabled
3	IM_CCA	0	R/W	Clear channel assessment (CCA) indicates that channel is clear 0 Interrupt disabled 1 Interrupt enabled
2	IM_CSP_WT	0	R/W	CSMA-CA/strobe processor (CSP) wait condition is true 0 Interrupt disabled 1 Interrupt enabled
1	IM_CSP_STOP	0	R/W	CSMA-CA/strobe processor (CSP) program execution stopped 0 Interrupt disabled 1 Interrupt enabled
0	IM_CSP_INT	0	R/W	CSMA-CA/strobe processor (CSP) INT instruction executed 0 Interrupt disabled 1 Interrupt enabled

**14.5 FIFO access**

The TXFIFO and RXFIFO may be accessed through the SFR register RFD (0xD9).

Data is written to the TXFIFO when writing to the RFD register. Data is read from the RXFIFO when the RFD register is read.

The RF register bits RFSTATUS.FIFO and RFSTATUS.FIFOP provide information on the data in the receive FIFO, as described in section 14.6 on page 157. Note that the

RFSTATUS.FIFO and RFSTATUS.FIFOP only apply to the RXFIFO.

The TXFIFO may be flushed by issuing a SFLUSHTX command strobe. Similarly, a SFLUSHRX command strobe will flush the receive FIFO.

The FIFO may contain 256 bytes (128 bytes for RX and 128 bytes for TX).

**RFD (0xD9) – RF Data**

Bit	Name	Reset	R/W	Description
7:0	RFD[7:0]	0x00	R/W	Data written to the register is written to the TXFIFO. When reading this register, data from the RXFIFO is read

**14.6 DMA**

It is possible, and in most cases recommended, to use direct memory access (DMA) to move data between memory and the radio. The DMA controller is described in section 13.5. Refer to this section for a detailed description on how to setup and use DMA transfers.

To support the DMA controller there is one DMA trigger associated with the radio, this is the RADIO DMA trigger (DMA trigger 19). The RADIO DMA trigger is activated by two events. The first event to cause a RADIO DMA trigger, is when the first data is present in the RXFIFO, i.e. when the RXFIFO goes from the empty state to the non-empty state. The second

Radio : Receive mode

event that causes a RADIO DMA trigger, is when data is read from the RXFIFO (through

RFD SFR register) and there is still more data available in the RXFIFO.

14.7 Receive mode

In receive mode, the interrupt flag `RFIF.IRQ_SFD` goes high and the RF interrupt is requested after the start of frame delimiter (SFD) field has been completely received. If address recognition is disabled or is successful, the `RFSTATUS.SFD` bit goes low again only after the last byte of the MPDU has been received. If the received frame fails address recognition, the `RFSTATUS.SFD` bit goes low immediately. This is illustrated in Figure 35.

number of bytes in the RXFIFO exceeds the programmed threshold.

The `RFSTATUS.FIFOP` bit will also go high when the last byte of a new packet is received, even if the threshold is not exceeded. If so the `RFSTATUS.FIFOP` bit will go back to low once one byte has been read out of the RXFIFO.

The `RFSTATUS.FIFO` bit is high when there is one or more data bytes in the RXFIFO. The first byte to be stored in the RXFIFO is the length field of the received frame, i.e. the `RFSTATUS.FIFO` bit is set high when the length field is written to the RXFIFO. The `RFSTATUS.FIFO` bit then remains high until the RXFIFO is empty. The RF register `RXFIFOCNT` contains the number of bytes present in the RXFIFO.

When address recognition is enabled, data should not be read out of the RXFIFO before the address is completely received, since the frame may be automatically flushed by **CC2430** if it fails address recognition. This may be handled by using the `RFSTATUS.FIFOP` bit, since this bit does not go high until the frame passes address recognition.

The `RFSTATUS.FIFOP` bit is high when the number of unread bytes in the RXFIFO exceeds the threshold programmed into `IOCFG0.FIFOP_THR`. When address recognition is enabled the `RFSTATUS.FIFOP` bit will not go high until the incoming frame passes address recognition, even if the

Figure 36 shows an example of status bit activity when reading a packet from the RXFIFO. In this example, the packet size is 8 bytes, `IOCFG0.FIFOP_THR = 3` and `MDMCTRL0L.AUTOCRC` is set. The length will be 8 bytes, RSSI will contain the average RSSI level during receiving of the packet and FCS/corr contains information of FCS check result and the correlation levels.

14.8 RXFIFO overflow

The RXFIFO can only contain a maximum of 128 bytes at a given time. This may be divided between multiple frames, as long as the total number of bytes is 128 or less. If an overflow occurs in the RXFIFO, this is signaled to the CPU by asserting the RFERR interrupt when enabled. In addition the radio will set `RFSTATUS.FIFO` bit low while the `RFSTATUS.FIFOP` bit is high. Data already in

the RXFIFO will not be affected by the overflow, i.e. frames already received may be read out.

A `SFLUSHRX` command strobe is required after a RXFIFO overflow to enable reception of new data.

Radio : Transmit mode

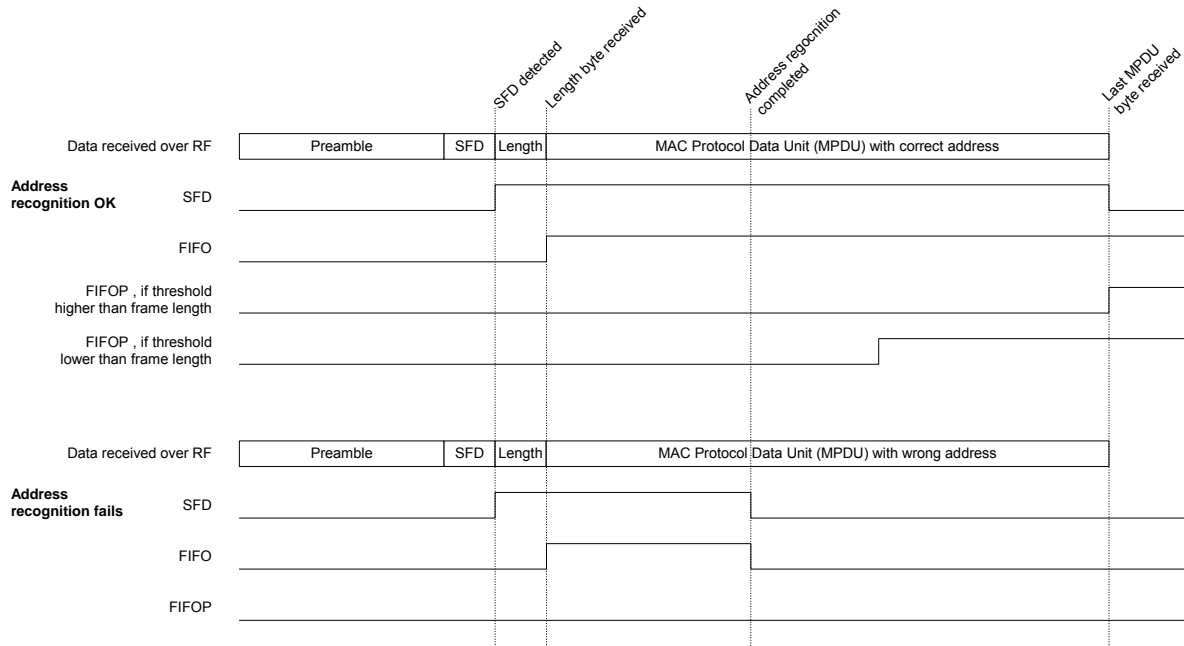

Figure 35: SFD, FIFO and FIFOP activity examples during receive

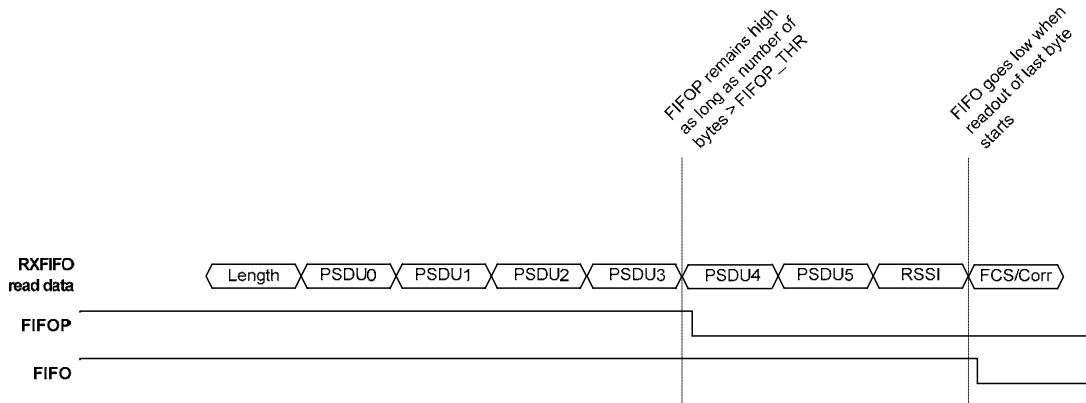

Figure 36: Example of status activity when reading RXFIFO.

14.9 Transmit mode

During transmit the `RFSTATUS.FIFO` and `RFSTATUS.FIFOP` bits are still only related to the `RXFIFO`. The `RFSTATUS.SFD` bit is however active during transmission of a data frame, as shown in Figure 37.

The `RFIF.IRQ_SFD` interrupt flag goes high and the RF interrupt is requested when the SFD field has been completely transmitted. It goes low again when the complete MPDU (as defined by the length field) has been transmitted or if an underflow is detected. The interrupt `RFERR` is then asserted if enabled.

See section 14.17.1 on page 163 for more information on `TXFIFO` underflow.

As can be seen from comparing Figure 35 and Figure 37, the `RFSTATUS.SFD` bit behaves very similarly during reception and transmission of a data frame. If the `RFSTATUS.SFD` bits of the transmitter and the receiver are compared during the transmission of a data frame, a small delay between 3.076  $\mu$ s and 3.284  $\mu$ s can be seen because of bandwidth limitations in both the transmitter and the receiver.

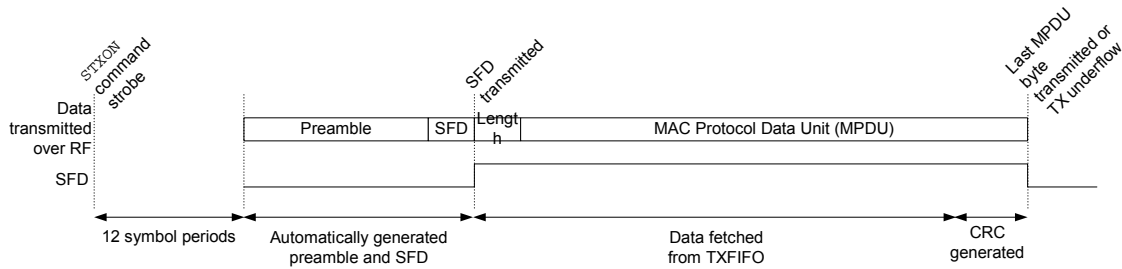

Figure 37: SFD status activity example during transmit

#### 14.10 General control and status

In receive mode, the `RFIF.IRQ_FIFOP` interrupt flag and RF interrupt request can be used to interrupt the CPU when a threshold has been exceeded or a complete frame has been received.

In receive mode, the `RFSTATUS.FIFO` bit can be used to detect if there is data at all in the receive FIFO.

The `RFIF.IRQ_SFD` interrupt flag can be used to extract the timing information of transmitted and received data frames. The `RFIF.IRQ_SFD` bit will go high when a start of frame delimiter has been completely detected / transmitted.

For debug purposes, the `RFSTATUS.SFD`, `RFSTATUS.FIFO`, `RFSTATUS.FIFOP` and `RFSTATUS.CCA` bits can be output onto P1.7 – P1.4 I/O pins to monitor the status of these signals as selected by the `IOCFG0`, `IOCFG1` and `IOCFG2` register.

The polarity of these signals given on the debug outputs can also be controlled by the `IOCFG0-2` registers, if needed.

#### 14.11 Demodulator, Symbol Synchronizer and Data Decision

The block diagram for the **CC2430** demodulator is shown in Figure 38. Channel filtering and frequency offset compensation is performed digitally. The signal level in the channel is estimated to generate the RSSI level (see the RSSI / Energy Detection section on page 168 for more information). Data filtering is also included for enhanced performance.

With the  $\pm 40$  ppm frequency accuracy requirement from [1], a compliant receiver must be able to compensate for up to 80 ppm or 200 kHz. The **CC2430** demodulator tolerates up to 300 kHz offset without significant degradation of the receiver performance.

Soft decision is used at the chip level, i.e. the demodulator does not make a decision for each chip, only for each received symbol. De-spreading is performed using over-sampling symbol correlators. Symbol synchronization is

achieved by a continuous start of frame delimiter (SFD) search.

When an SFD is detected, data is written to the RXFIFO and may be read out by the CPU at a lower bit rate than the 250 kbps generated by the receiver.

The **CC2430** demodulator also handles symbol rate errors in excess of 120 ppm without performance degradation. Resynchronization is performed continuously to adjust for error in the incoming symbol rate.

The RF register `MDMCTRL1H.CORR_THR` control bits should be written to 0x14 to set the threshold for detecting IEEE 802.15.4 start of frame delimiters.

Radio : Frame Format

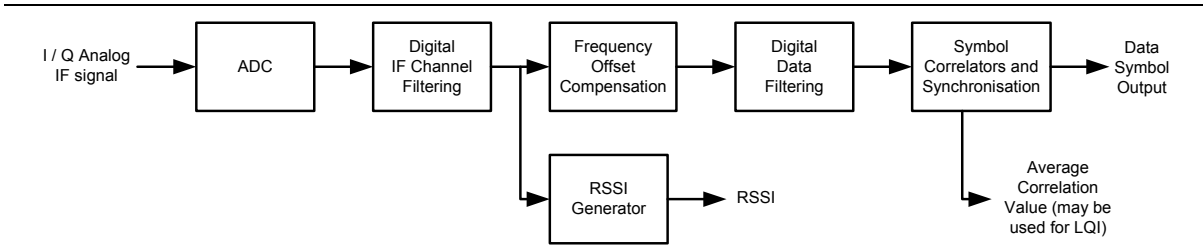

Figure 38: Demodulator Simplified Block Diagram

14.12 Frame Format

CC2430 has hardware support for parts of the IEEE 802.15.4 frame format. This section gives a brief summary to the IEEE 802.15.4 frame format, and describes how CC2430 is set up to comply with this.

Figure 39 [1] shows a schematic view of the IEEE 802.15.4 frame format. Similar figures describing specific frame formats (data frames, beacon frames, acknowledgment frames and MAC command frames) are included in [1].

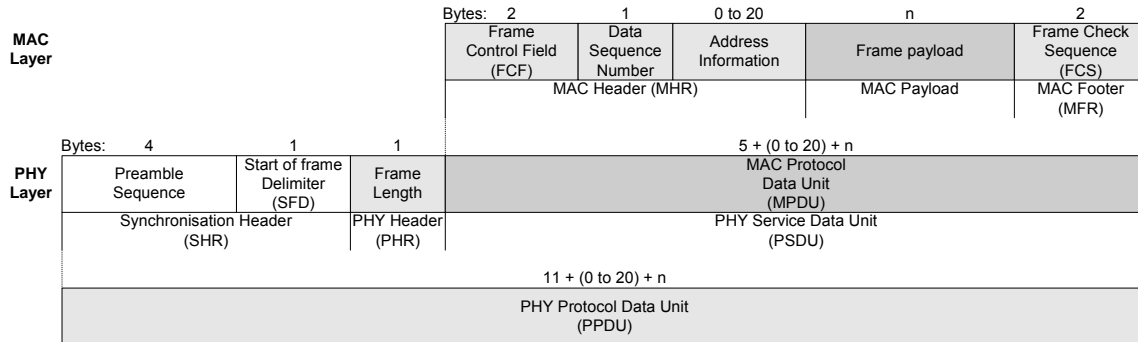

Figure 39: Schematic view of the IEEE 802.15.4 Frame Format [1]

14.13 Synchronization header

The synchronization header (SHR) consists of the preamble sequence followed by the start of frame delimiter (SFD). In [1], the preamble sequence is defined to be four bytes of 0x00. The SFD is one byte, set to 0xA7.

In CC2430, the preamble length and SFD is configurable. The default values are compliant with [1]. Changing these values will make the system non-compliant to IEEE 802.15.4.

A synchronization header is always transmitted first in all transmit modes.

The preamble sequence length can be set with RF register bit MDMCTRL0L.PREAMBLE\_LENGTH, while the SFD is programmed in the SYNCWORDH:SYNCWORDL registers. SYNCWORDH:SYNCWORDL is two bytes long, which gives the user some extra flexibility as described below. Figure 40 shows how the CC2430 synchronization header relates to the IEEE 802.15.4 specification.

The programmable preamble length only applies to transmission, it does not affect receive mode. The preamble length should not be set shorter than the default value. Note that 2 of the 8 zero-symbols in the preamble sequence required by [1] are included in the SYNCWORDH:SYNCWORDL registers so that the CC2430 preamble sequence is only 6 symbols long for compliance with [1]. Two additional zero symbols in SYNCWORDH:SYNCWORDL make CC2430 compliant with [1].

In reception, CC2430 synchronizes to received zero-symbols and searches for the SFD sequence defined by the SYNCWORDH:SYNCWORDL registers. The least significant symbols in SYNCWORDH:SYNCWORDL set to 0xF will be ignored, while symbols different from 0xF will be required for synchronization. The default setting of 0xA70F thereby requires one additional zero-symbol for synchronization. This will reduce the number of false frames detected due to noise.

Radio : Length field

In receive mode **CC2430** uses the preamble sequence for symbol synchronization and frequency offset adjustments. The SFD is

used for byte synchronization, and is not part of the data stored in the receive buffer (RXFIFO).

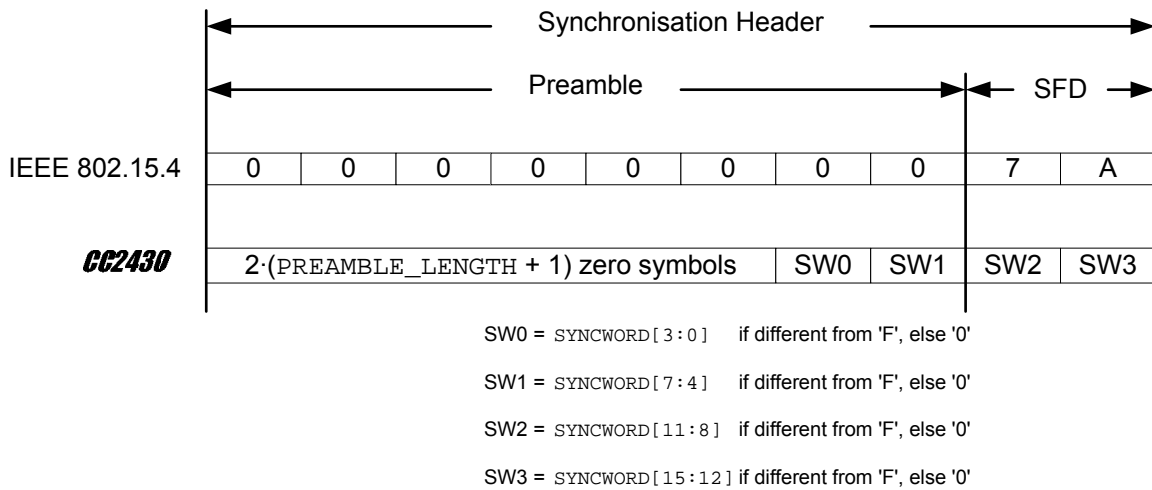

Figure 40: Transmitted Synchronization Header

14.14 Length field

The frame length field shown in Figure 39 defines the number of bytes in the MPDU. Note that the length field does not include the length field itself. It does however include the FCS (Frame Check Sequence), even if this is inserted automatically by **CC2430** hardware.

The length field is 7 bits and has a maximum value of 127. The most significant bit in the

length field is reserved [1], and should be set to zero.

**CC2430** uses the length field both for transmission and reception, so this field must always be included. In transmit mode, the length field is used for underflow detection, as described in the FIFO access section on page 157.

14.15 MAC protocol data unit

The FCF, data sequence number and address information follows the length field as shown in Figure 39. Together with the MAC data payload and Frame Check Sequence, they form the MAC Protocol Data Unit (MPDU).

The format of the FCF is shown in Figure 41. Please refer to [1] for details.

There is no hardware support for the data sequence number, this field must be inserted and verified by software.

**CC2430** includes hardware address recognition, as described in the Address Recognition section on page 164.

Bits: 0-2	3	4	5	6	7-9	10-11	12-13	14-15
Frame Type	Security Enabled	Frame Pending	Acknowledge request	Intra PAN	Reserved	Destination addressing mode	Reserved	Source addressing mode

Figure 41: Format of the Frame Control Field (FCF) [1]

14.16 Frame check sequence

A 2-byte frame check sequence (FCS) follows the last MAC payload byte as shown in Figure 39. The FCS is calculated over the MPDU, i.e. the length field is not part of the FCS. This field is automatically generated and verified by hardware when the RF register MDCTRL0L.AUTOCRC control bit is set. It is

recommended to always have this enabled, except possibly for debug purposes. If cleared, CRC generation and verification must be performed by software.

The FCS polynomial is [1]:  

$$x^{16} + x^{12} + x^5 + 1$$

Radio : RF Data Buffering

The **CC2430** hardware implementation is shown in Figure 42. Please refer to [1] for further details.

In transmit mode the FCS is appended at the correct position defined by the length field. The FCS is not written to the TXFIFO, but stored in a separate 16-bit register.

In receive mode the FCS is verified by hardware. The user is normally only interested in the correctness of the FCS, not the FCS sequence itself. The FCS sequence itself is therefore not written to the RXFIFO during receive.

Instead, when `MDMCTRL0L.AUTOCRC` is set the two FCS bytes are replaced by the RSSI value, average correlation value (used for LQI)

and CRC OK/not OK. This is illustrated in Figure 43.

The first FCS byte is replaced by the 8-bit RSSI value. See the RSSI section on page 168 for details.

The seven least significant bits in the last FCS byte are replaced by the average correlation value of the 8 first symbols of the received PHY header (length field) and PHY Service Data Unit (PSDU). This correlation value may be used as a basis for calculating the LQI. See the Link Quality Indication section on page 168 for details.

The most significant bit in the last byte of each frame is set high if the CRC of the received frame is correct and low otherwise.

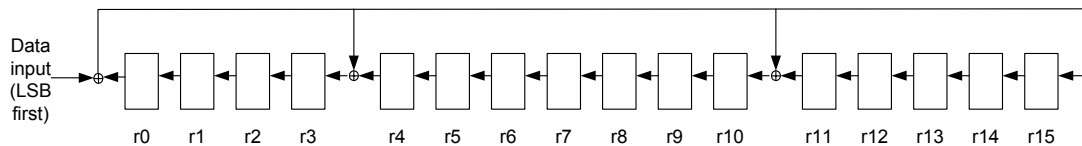

Figure 42: **CC2430** Frame Check Sequence (FCS) hardware implementation [1]

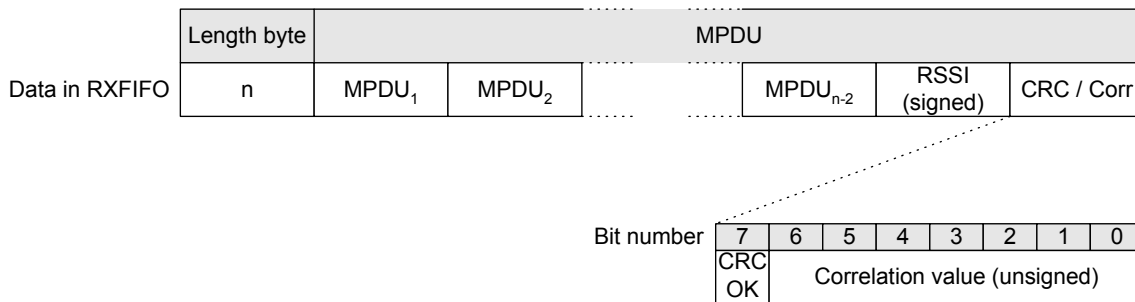

Figure 43: Data in RXFIFO when `MDMCTRL0L.AUTOCRC` is set

14.17 RF Data Buffering

**CC2430** can be configured for different transmit and receive modes, as set in the `MDMCTRL1L.TX_MODE` and `MDMCTRL1L.RX_MODE` control bits. Buffered

14.17.1 Buffered transmit mode

In buffered transmit mode (`TX_MODE=0`), the 128 byte TXFIFO is used to buffer data before transmission. A synchronization header is automatically inserted before the length field during transmission. The length field must always be the first byte written to the transmit buffer for all frames.

Writing one or multiple bytes to the TXFIFO is described in the FIFO access section on page 157. A DMA transfer can be configured to write transmit data to the TXFIFO.

mode (mode 0) will be used for normal operation of **CC2430**, while other modes are available for test purposes.

Transmission is enabled by issuing a `STXON` or `STXONCCA` command strobe. See the Radio control state machine section on page 166 for an illustration of how the transmit command strobes affect the state of **CC2430**. The `STXONCCA` strobe is ignored if the channel is busy. See section 14.25 on page 169 for details on CCA.

The preamble sequence is started 12 symbol periods after the transmit command strobe. After the programmable start of frame delimiter

Radio : Address Recognition

has been transmitted, data is fetched from the TXFIFO.

The TXFIFO can only contain one data frame at a given time.

After complete transmission of a data frame, the TXFIFO is automatically refilled with the last transmitted frame. Issuing a new STXON or

STXONCCA command strobe will then cause **CC2430** to retransmit the last frame.

Writing to the TXFIFO after a frame has been transmitted will cause the TXFIFO to be automatically flushed before the new byte is written. The only exception is if a TXFIFO underflow has occurred, when a SFLUSHTX command strobe is required.

14.17.2 Buffered receive mode

In buffered receive mode (RX\_MODE 0), the 128 byte RXFIFO, located in **CC2430** RAM, is used to buffer data received by the demodulator. Accessing data in the RXFIFO is described in the FIFO access section on page 157.

The RF interrupt generated by RFSTATUS.FIFOP and also the RFSTATUS.FIFO and RFSTATUS.FIFOP register bits are used to assist the CPU in supervising the RXFIFO. Please note that these status bits are only related to the RXFIFO, even if **CC2430** is in transmit mode.

A DMA transfer should be used to read data from the RXFIFO. In this case a DMA channel can be setup to use the RADIO DMA trigger (see DMA triggers on page 94) to initiate a DMA transfer using the RFD register as the DMA source.

Multiple data frames may be in the RXFIFO simultaneously, as long as the total number of bytes does not exceed 128.

See the RXFIFO overflow section on page 158 for details on how a RXFIFO overflow is detected and signaled.

14.18 Address Recognition

**CC2430** includes hardware support for address recognition, as specified in [1]. Hardware address recognition may be enabled or disabled using the MDMCTRL0H.ADDR\_DECODE control bit. Address recognition uses the following RF registers

- IEEE\_ADDR7-IEEE\_ADDR0
- PANIDH: PANIDL
- SHORTADDRH: SHORTADDRL

Address recognition is based on the following requirements, listed from section 7.5.6.2 in [1]:

- The frame type subfield shall not contain an illegal frame type
- If the frame type indicates that the frame is a beacon frame, the source PAN identifier shall match macPANId unless macPANId is equal to 0xFFFF, in which case the beacon frame shall be accepted regardless of the source PAN identifier.
- If a destination PAN identifier is included in the frame, it shall match macPANId or shall be the broadcast PAN identifier (0xFFFF).

- If a short destination address is included in the frame, it shall match either macShortAddress or the broadcast address (0xFFFF). Otherwise if an extended destination address is included in the frame, it shall match aExtendedAddress.
- If only source addressing fields are included in a data or MAC command frame, the frame shall only be accepted if the device is a PAN coordinator and the source PAN identifier matches macPANId.

If any of the above requirements are not satisfied and address recognition is enabled, **CC2430** will disregard the incoming frame and flush the data from the RXFIFO. Only data from the rejected frame is flushed, data from previously accepted frames may still be in the RXFIFO.

Incoming frames are first subject to frame type filtering according to the setting of the MDMCTRL0H.FRAME\_T\_FILT register bit.

Following the required frame type filtering, incoming frames with reserved frame types (FCF frame type subfield is 4, 5, 6 or 7) are however accepted if the RESERVED\_FRAME\_MODE control bit in the RF register MDMCTRL0H is set. In this case, no further address recognition is performed on

Radio : Acknowledge Frames

these frames. This option is included for future expansions of the IEEE 802.15.4 standard.

If a frame is rejected, **CC2430** will only start searching for a new frame after the rejected frame has been completely received (as defined by the length field) to avoid detecting false SFDs within the frame.

**14.19 Acknowledge Frames**

**CC2430** includes hardware support for transmitting acknowledge frames, as specified in [1]. Figure 44 shows the format of the acknowledge frame.

If `MDMCTRL0L.AUTOACK` is enabled, an acknowledge frame is transmitted for all

The `MDMCTRL0.PAN_COORDINATOR` control bit must be correctly set, since parts of the address recognition procedure requires knowledge about whether the current device is a PAN coordinator or not.

incoming frames accepted by the address recognition with the acknowledge request flag set and a valid CRC. `AUTOACK` therefore does not make sense unless also `ADDR_DECODE` and `AUTOCRC` are enabled. The sequence number is copied from the incoming frame.

Bytes: 4	1	1	2	1	2
Preamble Sequence	Start of Frame Delimiter (SFD)	Frame Length	Frame Control Field (FCF)	Data Sequence Number	Frame Check Sequence (FCS)
Synchronisation Header (SHR)		PHY Header (PHR)	MAC Header (MHR)		MAC Footer (MFR)

**Figure 44: Acknowledge frame format [1]**

Two command strobes, `SACK` and `SACKPEND` are defined to transmit acknowledge frames with the frame pending field cleared or set, respectively. The acknowledge frame is only transmitted if the CRC is valid.

For systems using beacons, there is an additional timing requirement that the acknowledge frame transmission may be started on the first backoff-slot boundary (20 symbol periods) at least 12 symbol periods after the last symbol of the incoming frame. When the RF register control bit `MDMCTRL1H.SLOTTED_ACK` is set to 1, the acknowledge frame is transmitted between 12 and 30 symbol periods after the incoming frame. The timing is defined such that there is an integer number of 20-symbol period backoff-slots between the incoming packet SFD and the transmitted acknowledge frame SFD. This timing is also illustrated in Figure 45.

Using `SACKPEND` will set the pending data flag for automatically transmitted acknowledge frames using `AUTOACK`. The pending flag will then be set also for future acknowledge frames, until a `SACK` command strobe is issued. The pending data flag that is transmitted will be logically OR'ed with the value of `FSMTC1.PENDING_OR`. Thus the pending flag can be set high using this register control bit.

When an acknowledge frame transmission completes, the RF Interrupt flag `RFIF.IRQ_TXDONE` will be set if this interrupt source is selected by setting RF register bit `IRQSRC.TXACK` to 1.

Acknowledge frames may be manually transmitted using normal data transmission if desired.

Radio : Radio control state machine

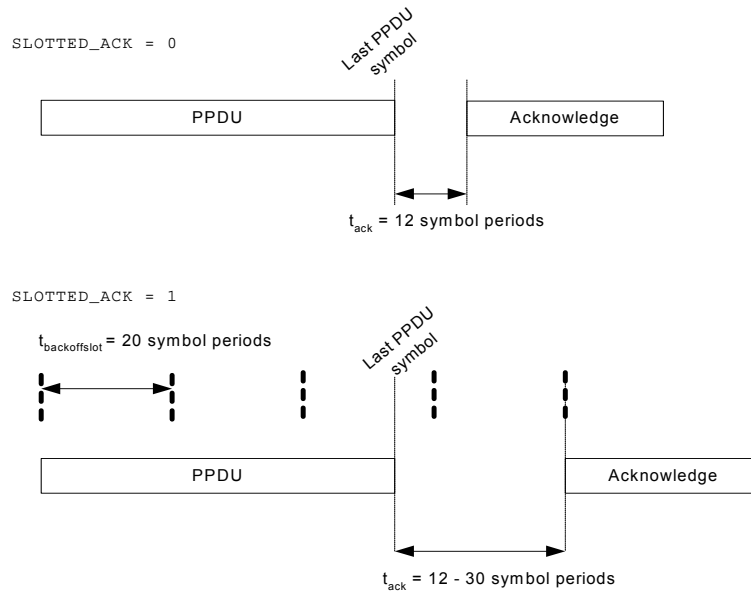

Figure 45: Acknowledge frame timing

14.20 Radio control state machine

CC2430 has a built-in state machine that is used to switch between different operation states (modes). The change of state is done either by using command strobes or by internal events such as SFD detected in receive mode.

The radio control state machine states are shown in Figure 46. The numbers in brackets refer to the state number readable in the FSMSTATE status register. Reading the FSMSTATE status register is primarily for test / debug purposes. The figure assumes that the device is already placed in the PM0 power mode.

Before using the radio in either RX or TX mode, the voltage regulator and crystal oscillator must be turned on and become stable. The voltage regulator and crystal oscillator startup times are given in the section 7.4 on page 14.

The voltage regulator for the radio is enabled by setting the RF register bit RFPWR.RREG\_RADIO\_PD to 0. The interrupt flag RFIF.IRQ\_RREG\_ON is set to 1 when the voltage regulator has powered-up.

The crystal oscillator is controlled through the Power Management Controller. The

SLEEP.XOSC\_STB bit indicates whether the oscillator is running and stable or not (see page 67). This SFR register can be polled when waiting for the oscillator to start. It should be noted that an additional wait time after this event until selecting XOSC as source is needed. This is described in section 13.1.4.2.

For test purposes, the frequency synthesizer (FS) can also be manually calibrated and started by using the STXCALN or ISTXCALN command strobe (see section 14.34 and Table 47). This will not start a transmission before a STXON command strobe is issued. This is not shown in Figure 46.

Enabling transmission is done by issuing a STXON or STXONCCA command strobe.

Turning off RF can be accomplished by using the SRFOFF command strobe.

After bringing the CC2430 up to Power Mode 0 (PM0) from a low-power mode e.g. Power Mode 3 (PM3), all RF registers will retain their values thus placing the chip ready to operate at the correct frequency and mode. Due to the very fast start-up time, CC2430 can remain in a low-power mode until a transmission session is requested.

Radio : Radio control state machine

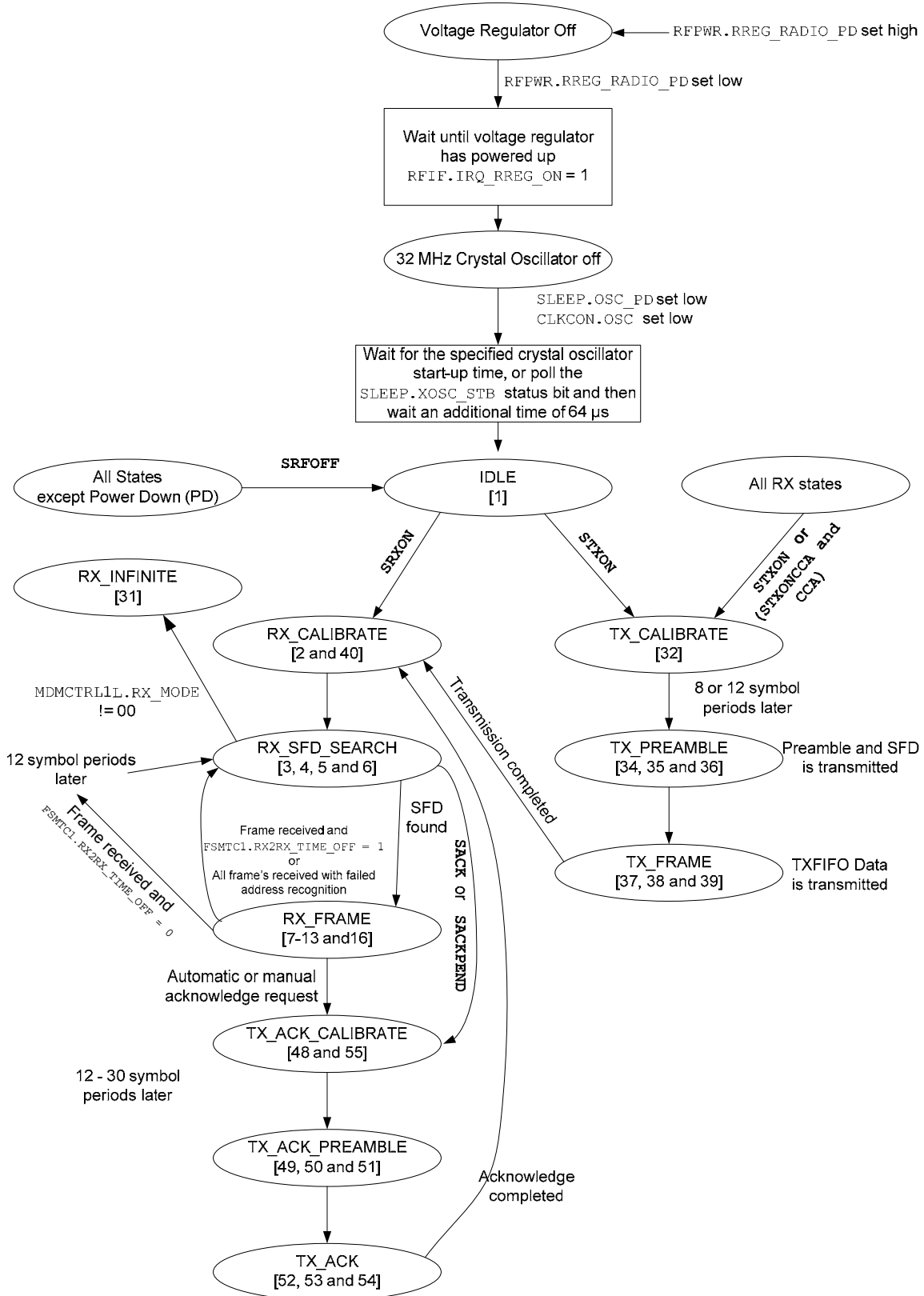

Figure 46: Radio control states

14.21 MAC Security Operations (Encryption and Authentication)

CC2430 features hardware IEEE 802.15.4 MAC security operations. Refer to section 13.12 on page 136 for a description of the AES encryption unit.

14.22 Linear IF and AGC Settings

CC2430 is based on a linear IF chain where the signal amplification is done in an analog VGA (variable gain amplifier). The gain of the VGA is digitally controlled.

The AGC (Automatic Gain Control) loop ensures that the ADC operates inside its

dynamic range by using an analog/digital feedback loop.

The AGC characteristics are set through the AGCCTRLH:AGCCTRLH, registers. The reset values should be used for all AGC control registers.

14.23 RSSI / Energy Detection

CC2430 has a built-in RSSI (Received Signal Strength Indicator) giving a digital value that can be read from the 8 bit, signed 2's complement RSSI.RSSI\_VAL register bits.

The RSSI value is always averaged over 8 symbol periods (128 μs), in accordance with [1].

The RSSI register value RSSI.RSSI\_VAL can be referred to the power P at the RF pins by using the following equations:

$$P = \text{RSSI\_VAL} + \text{RSSI\_OFFSET} \text{ [dBm]}$$

where the RSSI\_OFFSET is found empirically during system development from the front end gain. RSSI\_OFFSET is approximately -45. E.g. if reading a value of -20 from the RSSI register, the RF input power is approximately -65 dBm.

A typical plot of the RSSI\_VAL reading as function of input power is shown in Figure 47. It can be seen from the figure that the RSSI reading from CC2430 is very linear and has a dynamic range of about 100 dB.

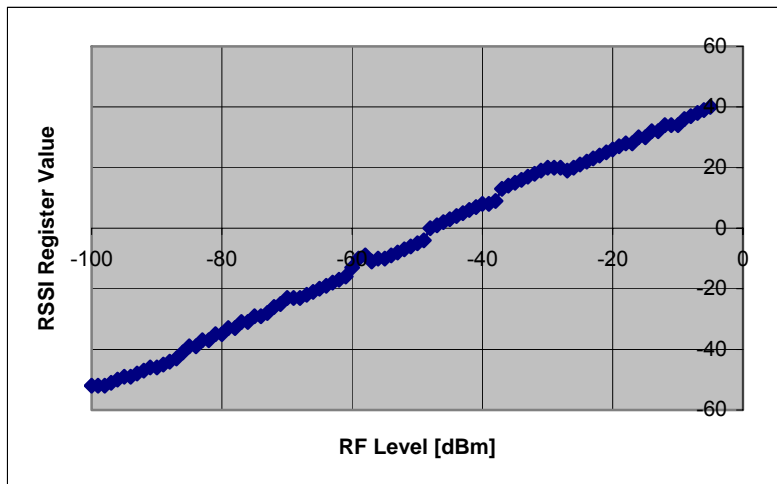

Figure 47: Typical RSSI value vs. input power

14.24 Link Quality Indication

The link quality indication (LQI) measurement is a characterization of the strength and/or quality of a received packet, as defined by [1].

The RSSI value described in the previous section may be used by the MAC software to produce the LQI value. The LQI value is required by [1] to be limited to the range 0 through 255, with at least eight unique values.

Software is responsible for generating the appropriate scaling of the LQI value for the given application.

Using the RSSI value directly to calculate the LQI value has the disadvantage that e.g. a narrowband interferer inside the channel bandwidth will increase the LQI value although it actually reduces the true link quality. CC2430

Radio : Clear Channel Assessment

therefore also provides an average correlation value for each incoming packet, based on the eight first symbols following the SFD. This unsigned 7-bit value, which should be as high as possible, can be looked upon as a indication of the “chip error rate,” although **CC2430** does not perform chip decision.

As described in the Frame check sequence section on page 162, the average correlation value for the eight first symbols is appended to each received frame together with the RSSI and CRC OK/not OK when `MDMCTRL0L.AUTOCRC` is set. A correlation value of approx. 110 indicates a maximum

**14.25 Clear Channel Assessment**

The clear channel assessment signal is based on the measured RSSI value and a programmable threshold. The clear channel assessment function is used to implement the CSMA-CA functionality specified in [1]. CCA is valid when the receiver has been enabled for at least 8 symbol periods.

Carrier sense threshold level is programmed by `RSSI.CCA_THR`. The threshold value can be programmed in steps of 1 dB. A CCA hysteresis can also be programmed in the `MDMCTRL0H.CCA_HYST` control bits.

All three CCA modes specified by [1] are implemented in **CC2430**. These are set in `MDMCTRL0L.CCA_MODE`, as can be seen in the register description. The different modes are:

quality frame while a value of approx. 50 is typically the lowest quality frames detectable by **CC2430**.

Software must convert the correlation value to the range 0-255 defined by [1], e.g. by calculating:

$$LQI = (CORR - a) \cdot b$$

limited to the range 0-255, where *a* and *b* are found empirically based on PER measurements as a function of the correlation value.

A combination of RSSI and correlation values may also be used to generate the LQI value.

- 00 Reserved
- 01 Clear channel when received energy is below threshold.
- 10 Clear channel when not receiving valid IEEE 802.15.4 data.
- 11 Clear channel when energy is below threshold and not receiving valid IEEE 802.15.4 data

Clear channel assessment is available on the `RFSTATUS.CCA` RF register bit. `RFSTATUS.CCA` is active high. This register bit will also set the interrupt flag `RFIF.IRQ_CCA`.

Implementing CSMA-CA may easiest be done by using the `STXONCCA` command strobe given by the CSMA-CA/strobe processor, as shown in the Radio control state machine section on page 166. Transmission will then only start if the channel is clear. The `TX_ACTIVE` status bit in the `RFSTATUS` RF register may be used to detect the result of the CCA.

**14.26 Frequency and Channel Programming**

The operating frequency is set by programming the 10 bit frequency word located in `FSCTRLH.FREQ[9:8]` and `FSCTRLH.FREQ[7:0]`. The operating frequency  $F_C$  in MHz is given by:

$$F_C = 2048 + \text{FREQ}[9:0] \text{ MHz}$$

where `FREQ[9:0]` is the value given by `FSCTRLH.FREQ[9:8]:FSCTRLH.FREQ[7:0]`

In receive mode the actual LO frequency is  $F_C - 2$  MHz, since a 2 MHz IF is used. Direct conversion is used for transmission, so here the LO frequency equals  $F_C$ . The 2 MHz IF is

automatically set by **CC2430**, so the frequency programming is equal for RX and TX.

IEEE 802.15.4 specifies 16 channels within the 2.4 GHz band, numbered 11 through 26. The RF frequency of channel *k* is given by [1]:

$$F_C = 2405 + 5(k-11) \text{ MHz}, k=11, 12, \dots, 26$$

For operation in channel *k*, the `FSCTRLH.FREQ:FSCTRLH.FREQ` register should therefore be set to:

$$\text{FSCTRLH.FREQ:FSCTRLH.FREQ} = 357 + 5(k-11)$$

**14.27 VCO and PLL Self-Calibration**

Radio : Output Power Programming

14.27.1 VCO

The VCO is completely integrated and operates at 4800 – 4966 MHz. The VCO frequency is divided by 2 to generate

frequencies in the desired band (2400-2483.5 MHz).

14.27.2 PLL self-calibration

The VCO's characteristics will vary with temperature, changes in supply voltages, and the desired operating frequency.

mode or TX mode is enabled, i.e. in the RX\_CALIBRATE, TX\_CALIBRATE and TX\_ACK\_CALIBRATE control states in Figure 46 on page 167.

In order to ensure reliable operation the VCO's bias current and tuning range are automatically calibrated every time the RX

14.28 Output Power Programming

The RF output power of the device is programmable and is controlled by the TXCTRL register. Table 45 shows the output power for different settings, including the complete programming of the TXCTRL

register and the current consumption in the whole device.

For optimum link quality it is recommended to set TXCTRL to 0x5F.

Table 45: Output power settings

Output Power [dBm]	TXCTRL register value	Device current consumption [mA]
0.6	0xFF	32.4
0.5	0xDF	31.3
0.3	0xBF	30.3
0.2	0x9F	29.2
-0.1	0x7F	28.1
-0.4	0x5F	26.9
-0.9	0x3F	25.7
-1.5	0x1F	24.5
-2.7	0x1B	23.6
-4.0	0x17	22.8
-5.7	0x13	21.9
-7.9	0x0F	21.0
-10.8	0x0B	20.1
-15.4	0x07	19.2
-18.6	0x06	18.8
-25.2	0x03	18.3

14.29 Input / Output Matching

The RF input / output is differential (RF\_N and RF\_P). In addition there is supply switch output pin (TXRX\_SWITCH) that must have an external DC path to RF\_N and RF\_P.

The RF output and DC bias can be done using different topologies. Some are shown in Figure 6 on page 28.

In RX mode the TXRX\_SWITCH pin is at ground and will bias the LNA. In TX mode the TXRX\_SWITCH pin is at supply rail voltage and will properly bias the internal PA.

Component values are given in Table 23 on page 29. If a differential antenna is implemented, no balun is required.

If a single ended output is required (for a single ended connector or a single ended antenna), a balun should be used for optimum performance.

14.30 Transmitter Test Modes

CC2430 can be set into different transmit test modes for performance evaluation. The test mode descriptions in the following sections requires that the chip is first reset, the crystal

oscillator is selected using the CLKCON register and that the crystal oscillator has stabilized.

14.30.1 Unmodulated carrier

An unmodulated carrier may be transmitted by setting MDMCTRL1L.TX\_MODE to 2, writing 0x1800 to the DACTSTH:DACTSTL registers and issue a STXON command strobe. The transmitter is then enabled while the

transmitter I/Q DACs are overridden to static values. An un-modulated carrier will then be available on the RF output pins.

A plot of the single carrier output spectrum from CC2430 is shown in Figure 48 below.

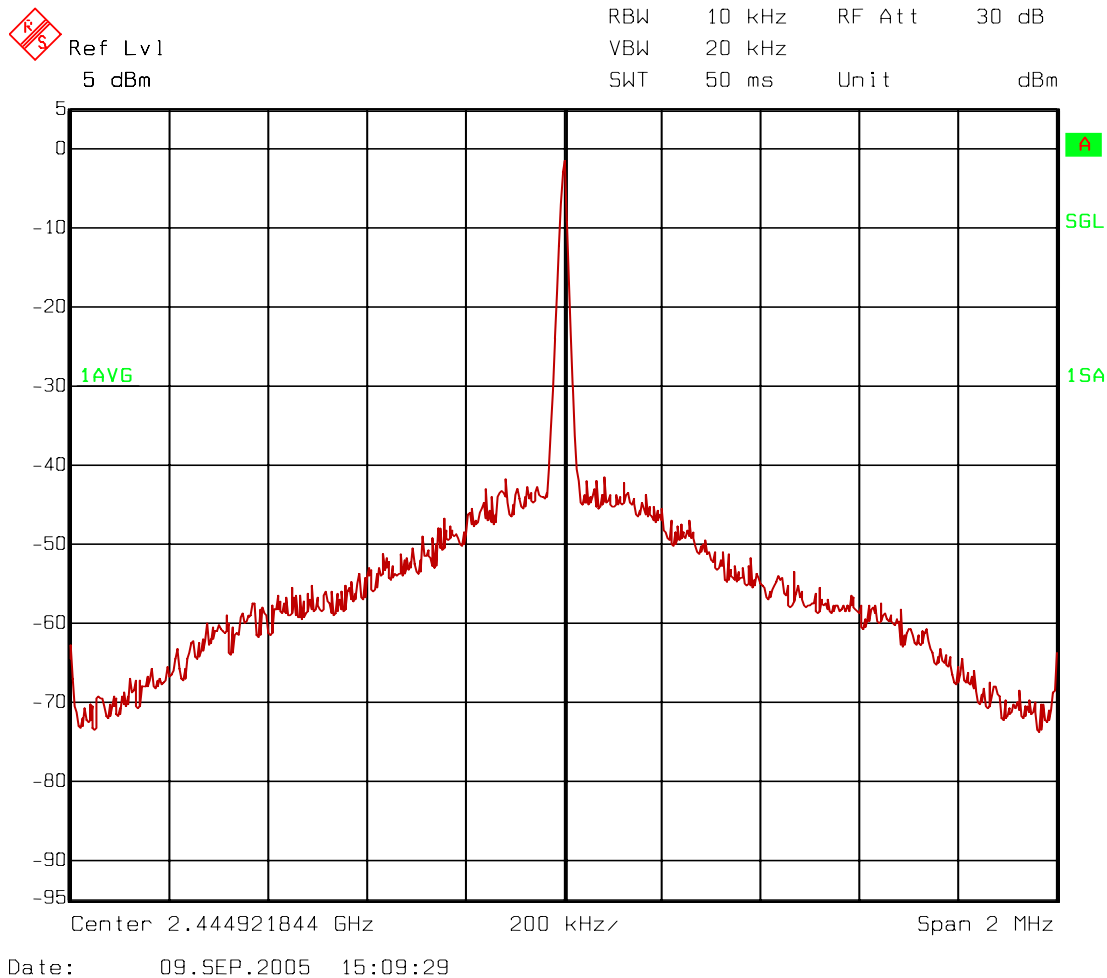

Figure 48: Single carrier output

14.30.2 Modulated spectrum

The CC2430 has a built-in test pattern generator that can generate a pseudo random sequence using the CRC generator. This is enabled by setting MDMCTRL1L.TX\_MODE to 3 and issuing a STXON command strobe. The modulated spectrum is then available on the RF pins. The low byte of the CRC word is transmitted and the CRC is updated with 0xFF

for each new byte. The length of the transmitted data sequence is 65535 bits. The transmitted data-sequence is then:

[synchronization header] [0x00, 0x78, 0xb8, 0x4b, 0x99, 0xc3, 0xe9, ...]

Since a synchronization header (preamble and SFD) is transmitted in all TX modes, this test mode may also be used to transmit a known

Radio : Transmitter Test Modes

pseudorandom bit sequence for bit error testing. Please note that **CC2430** requires symbol synchronization, not only bit synchronization, for correct reception. Packet error rate is therefore a better measurement for the true RF performance.

Another option to generate a modulated spectrum is to fill the TXFIFO with pseudo-random data and set `MDMCTRL1L.TX_MODE` to 2. **CC2430** will then transmit data from the FIFO disregarding a TXFIFO underflow. The length of the transmitted data sequence is then 1024 bits (128 bytes).

A plot of the modulated spectrum from **CC2430** is shown in Figure 49. Note that to find the output power from the modulated spectrum, the RBW must be set to 3 MHz or higher.

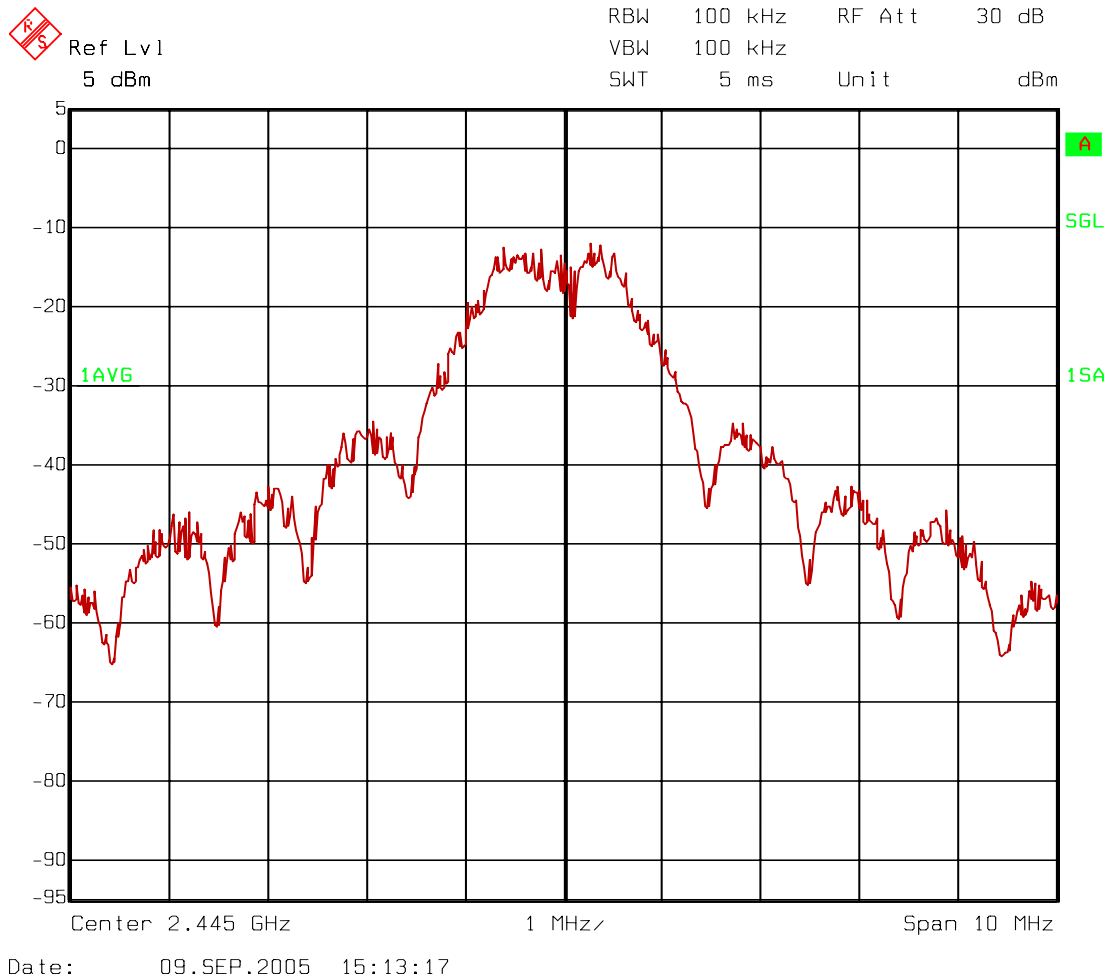

Figure 49: Modulated spectrum plot

## 14.31 System Considerations and Guidelines

### 14.31.1 SRD regulations

International regulations and national laws regulate the use of radio receivers and transmitters. SRDs (Short Range Devices) for license free operation are allowed to operate in the 2.4 GHz band worldwide. The most

important regulations are ETSI EN 300 328 and EN 300 440 (Europe), FCC CFR-47 part 15.247 and 15.249 (USA), and ARIB STD-T66 (Japan).

### 14.31.2 Frequency hopping and multi-channel systems

The 2.4 GHz band is shared by many systems both in industrial, office and home environments. **CC2430** uses direct sequence spread spectrum (DSSS) as defined by [1] to spread the output power, thereby making the communication link more robust even in a noisy environment.

802.15.4 system. This is achieved by reprogramming the operating frequency (see the Frequency and Channel Programming section on page 169) before enabling RX or TX. A frequency synchronization scheme must then be implemented within the proprietary MAC layer to make the transmitter and receiver operate on the same RF channel.

With **CC2430** it is also possible to combine both DSSS and FHSS (frequency hopping spread spectrum) in a proprietary non-IEEE

### 14.31.3 Data burst transmissions

The data buffering in **CC2430** lets the user have a lower data rate link between the CPU and the radio module than the RF bit rate of 250 kbps. This allows the CPU to buffer data at its own speed, reducing the workload and timing requirements. DMA transfers may be used to efficiently move data to and from the radio FIFOs.

The relatively high data rate of **CC2430** also reduces the average power consumption compared to the 868 / 915 MHz bands defined by [1], where only 20 / 40 kbps are available. **CC2430** may be powered up a smaller portion of the time, so that the average power consumption is reduced for a given amount of data to be transferred.

### 14.31.4 Crystal accuracy and drift

A crystal accuracy of  $\pm 40$  ppm is required for compliance with IEEE 802.15.4 [1]. This accuracy must also take ageing and temperature drift into consideration.

total frequency offset between the transmitter and receiver. This could e.g. relax the accuracy requirement to 60 ppm for each of the devices.

A crystal with low temperature drift and low aging could be used without further compensation. A trimmer capacitor in the crystal oscillator circuit (in parallel with C191 in Figure 6) could be used to set the initial frequency accurately.

Optionally in a star network topology, the full-function device (FFD) could be equipped with a more accurate crystal thereby relaxing the requirement on the reduced-function device (RFD). This can make sense in systems where the reduced-function devices ship in higher volumes than the full-function devices.

For non-IEEE 802.15.4 systems, the robust demodulator in **CC2430** allows up to 140 ppm

### 14.31.5 Communication robustness

**CC2430** provides very good adjacent, alternate and co channel rejection, image frequency suppression and blocking properties. The **CC2430** performance is significantly better than the requirements imposed by [1]. These are

highly important parameters for reliable operation in the 2.4 GHz band, since an increasing number of devices/systems are using this license free frequency band.

### 14.31.6 Communication security

The hardware encryption and authentication operations in **CC2430** enable secure

communication, which is required for many applications. Security operations require a lot

## Radio : System Considerations and Guidelines

of data processing, which is costly in an 8-bit microcontroller system. The hardware support

### 14.31.7 Low cost systems

As the **CC2430** provides 250 kbps multi-channel performance without any external filters, a very low cost system can be made (e.g. two layer PCB with single-sided component mounting).

### 14.31.8 Battery operated systems

In low power applications, the **CC2430** should be placed in the low-power modes PM2 or PM3 when not being active. Ultra low power

### 14.31.9 BER / PER measurements

**CC2430** includes test modes where data is received infinitely and output to pins. The required test modes are selected with the RF register bits `MDMCTRL1L.TX_MODE[1:0]` and `MDMCTRL1L.RX_MODE[1:0]`. These modes may be used for Bit Error Rate (BER) measurements. However, the following precautions must be taken to perform such a measurement:

- A preamble and SFD sequence must be used, even if pseudo random data is transmitted, since receiving the DSSS modulated signal requires *symbol* synchronization, not *bit* synchronization like e.g. in 2FSK systems. The `SYNCWORDH:SYNCWORDL` may be set to another value to fit to the measurement setup if necessary.
- The data transmitted over air must be spread according to [1] and the description on page 154. This means that the transmitter used during measurements must be able to do spreading of the bit data to chip data. Remember that the *chip* sequence transmitted by the test setup is not the same as the *bit* sequence, which is output by **CC2430**.
- When operating at or below the sensitivity limit, **CC2430** may lose symbol synchronization in infinite receive mode. A new SFD and restart of the receiver may be required to re-gain synchronization.

In an IEEE 802.15.4 system, all communication is based on packets. The sensitivity limit specified by [1] is based on Packet Error Rate (PER) measurements instead of BER. This is a more realistic measurement of the true RF performance since it mirrors the way the actual system operates.

within **CC2430** enables a high level of security with minimum CPU processing requirements.

A differential antenna will eliminate the need for a balun, and the DC biasing can be achieved in the antenna topology.

consumption may be achieved since the voltage regulators are turned off.

It is recommended to perform PER measurements instead of BER measurements to evaluate the performance of IEEE 802.15.4 systems. To do PER measurements, the following may be used as a guideline:

- A valid preamble, SFD and length field must be used for each packet.
- The PSDU (see Figure 39 on page 161) length should be 20 bytes for sensitivity measurements as specified by [1].
- The sensitivity limit specified by [1] is the RF level resulting in a 1% PER. The packet sample space for a given measurement must then be  $\gg 100$  to have a sufficiently large sample space. E.g. at least 1000 packets should be used to measure the sensitivity.
- The data transmitted over air must be spread according to [1] and the description on page 154. Pre-generated packets may be used, although [1] requires that the PER is averaged over random PSDU data.
- The **CC2430** receive FIFO may be used to buffer data received during PER measurements, since it is able to buffer up to 128 bytes.
- The `MDMCTRL1H.CORR_THR` control register should be set to 20, as described in the Demodulator, Symbol Synchronizer and Data Decision section.

The simplest way of making a PER measurement will be to use another **CC2430** as the reference transmitter. However, this makes it difficult to measure the exact receiver performance.

Using a signal generator, this may either be set up as O-QPSK with half-sine shaping or as MSK. If using O-QPSK, the phases must be selected according to [1]. If using MSK, the

Radio : PCB Layout Recommendation

chip sequence must be modified such that the modulated MSK signal has the same phase shifts as the O-QPSK sequence previously defined.

For a desired symbol sequence  $s_0, s_1, \dots, s_{n-1}$  of length  $n$  symbols, the desired chip sequence  $c_0, c_1, c_2, \dots, c_{32n-1}$  of length  $32n$  is found using table lookup from Table 44 on

### 14.32 PCB Layout Recommendation

In the Texas Instruments reference design, the top layer is used for signal routing, and the open areas are filled with metallization connected to ground using several vias. The area under the chip is used for grounding and must be well connected to the ground plane with several vias.

The ground pins should be connected to ground as close as possible to the package pin using individual vias. The de-coupling capacitors should also be placed as close as possible to the supply pins and connected to the ground plane by separate vias. Supply power filtering is very important.

### 14.33 Antenna Considerations

**CC2430** can be used together with various types of antennas. A differential antenna like a dipole would be the easiest to interface not needing a balun (balanced to un-balanced transformation network).

The length of the  $\lambda/2$ -dipole antenna is given by:

$$L = 14250 / f$$

where  $f$  is in MHz, giving the length in cm. An antenna for 2450 MHz should be 5.8 cm. Each arm is therefore 2.9 cm.

Other commonly used antennas for short-range communication are monopole, helical and loop antennas. The single-ended monopole and helical would require a balun network between the differential output and the antenna.

Monopole antennas are resonant antennas with a length corresponding to one quarter of the electrical wavelength ( $\lambda/4$ ). They are very easy to design and can be implemented simply as a "piece of wire" or even integrated into the PCB.

The length of the  $\lambda/4$ -monopole antenna is given by:

$$L = 7125 / f$$

page 154. It can be seen from comparing the phase shifts of the O-QPSK signal with the frequency of a MSK signal that the MSK chip sequence is generated as:

$$(c_0 \text{ xnor } c_1), (c_1 \text{ xor } c_2), (c_2 \text{ xnor } c_3), \dots, (c_{32n-1} \text{ xor } c_{32n})$$

where  $c_{32n}$  may be arbitrarily selected.

The external components should be as small as possible (0402 is recommended) and surface mount devices must be used.

If using any external high-speed digital devices, caution should be used when placing these in order to avoid interference with the RF circuitry.

A Development Kit, CC2430DK, with a fully assembled Evaluation Module is available. It is strongly advised that this reference layout is followed very closely in order to obtain the best performance.

The schematic, BOM and layout Gerber files for the reference designs are all available from the TI website.

where  $f$  is in MHz, giving the length in cm. An antenna for 2450 MHz should be 2.9 cm.

Non-resonant monopole antennas shorter than  $\lambda/4$  can also be used, but at the expense of range. In size and cost critical applications such an antenna may very well be integrated into the PCB.

Enclosing the antenna in high dielectric constant material reduces the overall size of the antenna. Many vendors offer such antennas intended for PCB mounting.

Helical antennas can be thought of as a combination of a monopole and a loop antenna. They are a good compromise in size critical applications. Helical antennas tend to be more difficult to optimize than the simple monopole.

Loop antennas are easy to integrate into the PCB, but are less effective due to difficult impedance matching because of their very low radiation resistance.

For low power applications the differential antenna is recommended giving the best range and because of its simplicity.

Radio : CSMA/CA Strobe Processor

The antenna should be connected as close as possible to the IC. If the antenna is located away from the RF pins the antenna should be

matched to the feeding transmission line (50Ω).

**14.34 CSMA/CA Strobe Processor**

The Command Strobe/CSMA-CA Processor (CSP) provides the control interface between the CPU and the Radio module in the **CC2430**.

Strobe instruction is also used only to control the CSP. The Immediate Command Strobe instructions are described in section 14.34.7.

The CSP interfaces with the CPU through the SFR register *RFST* and the RF registers *CSPX*, *CSPY*, *CSPZ*, *CSPT* and *CSPCTRL*. The CSP produces interrupt requests to the CPU. In addition the CSP interfaces with the MAC Timer by observing MAC Timer overflow events.

Program execution mode means that the CSP executes a sequence of instructions, from a program memory or instruction memory, thus constituting a short user-defined program. The available instructions are from a set of 14 instructions. The instruction set is defined in section 14.34.8. The required program is first loaded into the CSP by the CPU, and then the CPU instructs the CSP to start executing the program.

The CSP allows the CPU to issue command strobes to the radio thus controlling the operation of the radio.

The program execution mode together with the MAC Timer allows the CSP to automate CSMA-CA algorithms and thus act as a co-processor for the CPU.

The CSP has two modes of operation as follows, which are described below.

- Immediate Command Strobe execution.
- Program execution

The operation of the CSP is described in detail in the following sections. The command strobes and other instructions supported by the CSP are given in section 14.34.8 on page 179.

Immediate Command Strobes are written as an Immediate Command Strobe instruction to the CSP which are issued instantly to the Radio module. The Immediate Command

**RFST (0xE1) – RF CSMA-CA/Strobe Processor**

Bit	Name	Reset	R/W	Description
7:0	INSTR[7:0]	0xC0	R/W	Data written to this register will be written to the CSP instruction memory. Reading this register will return the CSP instruction currently being executed.

**14.34.1 Instruction Memory**

The CSP executes single byte program instructions which are read from a 24 byte instruction memory. The instruction memory is written to sequentially through the SFR register *RFST*. An instruction write pointer is maintained within the CSP to hold the location within the instruction memory where the next instruction written to *RFST* will be stored. Following a reset the write pointer is reset to location 0. During each *RFST* register write, the write pointer will be incremented by 1 until the end of memory is reached when the write pointer will stop incrementing, thus writing more than 24 bytes only the last byte written will be stored in the last position. The first instruction written to *RFST* will be stored in location 0, the location where program execution starts. Thus a complete CSP program may contain a maximum of 24 bytes that is written to the instruction memory by writing each instruction in the desired order to

the *RFST* register. Note that the program memory does not need to be filled, thus a CSP program may contain less than 24 bytes.

The write pointer may be reset to 0 by writing the immediate command strobe instruction *ISSTOP*. In addition the write pointer will be reset to 0 when the command strobe *SSTOP* is executed in a program.

Following a reset, the instruction memory is filled with *SNOP* (No Operation) instructions (opcode value 0xC0).

While the CSP is executing a program, there shall be no attempts to write instructions to the instruction memory by writing to *RFST*. Failure to observe this rule can lead to incorrect program execution and corrupt instruction memory contents. However, Immediate Command Strobe instructions may be written to *RFST* (see section 14.34.3).

#### 14.34.2 Data Registers

The CSP has three data registers CSPT, CSPX, CSPY and CSPZ, which are read/write accessible for the CPU as RF registers. These registers are read or modified by some instructions, thus allowing the CPU to set parameters to be used by a CSP program or allowing the CPU to read CSP program status.

The CSPT data register is not modified by any instruction. The CSPT data register is used to set a MAC Timer overflow compare value. Once program execution has started on the CSP, the content of this register is

decremented by 1 each time the MAC timer overflows. When CSPT reaches zero, program execution is halted and the interrupt IRQ\_CSP\_STOP is asserted. The CSPT register will not be decremented if the CPU writes 0xFF to this register.

*Note: If the CSPT register compare function is not used, this register must be set to 0xFF before the program execution is started.*

#### 14.34.3 Program Execution

After the instruction memory has been filled, program execution is started by writing the immediate command strobe instruction ISSTART to the RFST register. The program execution will continue until either the instruction at last location has been executed, the CSPT data register contents is zero, a SSTOP instruction has been executed, an immediate ISSTOP instruction is written to RFST or until a SKIP instruction returns a location beyond the last location in the instruction memory. The CSP runs at 8 MHz clock frequency.

Immediate Command Strobe instructions may be written to RFST while a program is being executed. In this case the Immediate instruction will bypass the instruction in the instruction memory, which will be completed once the Immediate instruction has been completed.

During program execution, reading RFST will return the current instruction being executed. An exception to this is the execution of immediate command strobes, during which RFST will return C0h.

#### 14.34.4 Interrupt Requests

The CSP has three interrupts flags which can produce the RF interrupt vector. These are the following:

- IRQ\_CSP\_STOP: asserted when the processor has executed the last instruction in memory and when the processor stops due to a SSTOP or ISSTOP instruction or CSPT register equal zero.

- IRQ\_CSP\_WT: asserted when the processor continues executing the next instruction after a WAIT W or WAITX instruction.
- IRQ\_CSP\_INT: asserted when the processor executes an INT instruction.

#### 14.34.5 Random Number Instruction

There will be a delay in the update of the random number used by the RANDXY instruction. Therefore if an instruction, RANDXY, that uses this value is issued

immediately after a previous RANDXY instruction, the random value read may be the same in both cases.

#### 14.34.6 Running CSP Programs

The basic flow for loading and running a program on the CSP is shown in Figure 50.

When program execution stops due to end of program the current program remains in program memory. This makes it possible to run the same program again by starting execution with the ISSTART command. However, when program execution is stopped

by the SSTOP or ISTOP instruction, the program memory will be cleared. It is also important to note that a WAIT W or WEVENT instruction can not be executed between X register update and X data read by one of the following instructions: RPT, SKIP or WAITX. If this is done the CSPX register will be decremented on each MAC timer (Timer2) overflow occurrence.

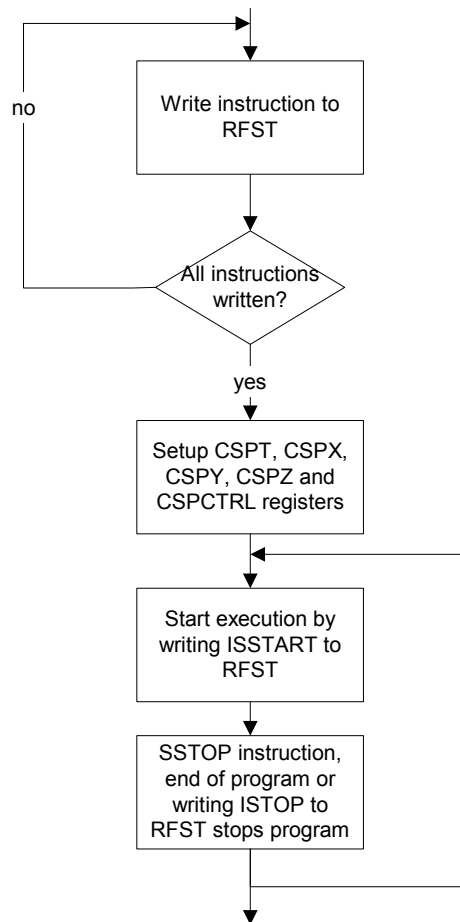

Figure 50: Running a CSP program

14.34.7 Instruction Set Summary

This section gives an overview of the instruction set. This is intended as a summary and definition of instruction opcodes. Refer to section 14.34.8 for a description of each instruction.

Each instruction consists of one byte which is written to the RFST register to be stored in the instruction memory.

The Immediate Strobe instructions (ISxxx) are not used in a program. When these instructions are written to the RFST register,

they are executed immediately. If the CSP is already executing a program the current instruction will be delayed until the Immediate Strobe instruction has completed.

For undefined opcodes, the behavior of the CSP is defined as a No Operation Strobe Command (SNOP).

Radio : CSMA/CA Strobe Processor

Table 46: Instruction Set Summary

Mnemonic	Opcode Bit number								Description <sup>11</sup>
	7	6	5	4	3	2	1	0	
SKIP C,S	0	S			N	C			Skip S instructions when condition (C xor N) is true. See Table 48 for C conditional codes
WAIT W	1	0	0	W					Wait for W number of MAC Timer overflows. If W is zero, wait for 32 MAC Timer overflows
WEVENT	1	0	1	1	1	0	0	0	Wait until MAC Timer value is greater than or equal to compare value in T2CMP
WAITX	1	0	1	1	1	0	1	1	Wait for CSPX number of backoffs. When CSPX is zero there is no wait.
LABEL	1	0	1	1	1	0	1	0	Label next instruction as loop start
RPT	1	0	1	0	N	C			Repeat from start of loop if condition (C xor N) is true. See Table 48 for C conditional codes
INT	1	0	1	1	1	0	0	1	Assert interrupt
INCY	1	0	1	1	1	1	0	1	Increment CSPY
INCMAXY	1	0	1	1	0	M			Increment CSPY not greater than M
DECY	1	0	1	1	1	1	1	0	Decrement CSPY
DECZ	1	0	1	1	1	1	1	1	Decrement CSPZ
RANDXY	1	0	1	1	1	1	0	0	Load CSPX with CSPY bit random value.
Sxxx	1	1	0	STRB					Command strobe instructions
ISxxx	1	1	1	STRB					Immediate strobe instructions

<sup>11</sup> Refer to Table 47 for full description of each instruction

14.34.8 Instruction Set Definition

There are 14 basic instruction types. Furthermore the Command Strobe and Immediate Strobe instructions can each be divided into eleven sub-instructions giving an effective number of 34 different instructions. Table 47 describe each instruction.

Note: the following definitions are used in this section

- PC = CSP program counter
- X = RF register CSPX
- Y = RF register CSPY
- Z = RF register CSPZ
- T = RF register CSPT
- ! = not
- > = greater than
- < = less than
- | = bit wise or



Radio : CSMA/CA Strobe Processor

MMONIC	OPCODE	Function	Operation	Description
STOP	0xCDF	Stop program execution	Stop exec, PC:=0, write pointer:=0	The SSTOP instruction stops the cleared, any/loop start location s IRQ_CSP_STOP interrupt flag is
SNOP	0xC0	No Operation	PC := PC + 1	Operation continues at the next
STXCALN	0xC1	Enable and calibrate freq. synth. for TX	STXCALN	The STXCALN instruction enables instruction waits for the radio to instruction. NOTE: Only for test
SRXON	0xC2	Enable and calibrate freq. synth. for RX	SRXON	The SRXON instruction asserts calibrate frequency synthesizer acknowledge the command before
STXON	0xC3	Enable TX after calibration	STXON	The STXON instruction enables to acknowledge the command b
STXONCCA	0xC4	Enable calibration and TX if CCA indicated a clear channel	STXONCCA	STXONCCA instruction enables The instruction waits for the radi next instruction. Note that this st FSWTCL1.RX2RX_TIME_OFF is s be 192 μs.
SROFF	0xC5	Disable RX/TX and freq. synth.	SROFF	The SROFF instruction asserts instruction waits for the radio to instruction.
SFLUSHRX	0xC6	Flush RXFIFO buffer and reset demodulator	SFLUSHRX	The SFLUSHRX instruction flushes The instruction waits for the radi next instruction.
SFLUSHTX	0xC7	Flush TXFIFO buffer	SFLUSHTX	The SFLUSHTX instruction flushes radio to acknowledge the comm
SACK	0xC8	Send acknowledge frame with pending field cleared	SACK	The SACK instruction sends an to acknowledge the command b
SACKPEND	0xC9	Send acknowledge frame when pending field set	SACKPEND	The SACKPEND instruction sen instruction waits for the radio to instruction.
ISSTOP	0xFF	Stop program execution	Stop execution	ISSTOP instruction stops the CS cleared, any/loop start location s IRQ_CSP_STOP interrupt flag is
ISSTART	0xFE	Start program execution	PC := 0, start execution	The ISSTART instruction starts written to instruction memory.
ISTXCALN	0xE1	Enable and calibrate freq. synth. for TX	STXCALN	ISTXCALN instruction immediat TX. The instruction waits for the the next instruction.

Radio : CSMA/CA Strobe Processor

NMONIC	OPCODE	Function	Operation	Description
ISRXON	0xE2	Enable and calibrate freq. synth. for RX	SRXON	The ISRXON instruction immediately enables the radio for RX. The instruction waits for the next instruction.
ISTXON	0xE3	Enable TX after calibration	STXON_STRB	The ISTXON instruction immediately enables the radio to acknowledge the next instruction.
ISTXONCCA	0xE4	Enable calibration and TX if CCA indicates a clear channel	STXONCCA	The ISTXONCCA instruction immediately enables the radio to acknowledge the next instruction before executing the next instruction.
ISRFOFF	0xE5	Disable RX/TX and freq. synth.	FFCTL_SRFOFF_STRB = 1	The ISRFOFF instruction immediately disables the radio for the next instruction.
ISFLUSHRX	0xE6	Flush RXFIFO buffer and reset demodulator	SFLUSHRX	ISFLUSHRX instruction flushes the RXFIFO buffer and resets the demodulator. The instruction waits for the radio to receive an acknowledgment before executing the next instruction. Note that for competition, the instruction waits for the radio to receive an acknowledgment before executing the next instruction.
ISFLUSHTX	0xE7	Flush TXFIFO buffer	SFLUSHTX	ISFLUSHTX instruction immediately flushes the TXFIFO buffer. The instruction waits for the radio to receive an acknowledgment before executing the next instruction.
ISACK	0xE8	Send acknowledge frame with pending field cleared	SACK	The ISACK instruction immediately sends an acknowledge frame with the pending field cleared. The instruction waits for the radio to receive an acknowledgment before executing the next instruction.
ISACKPEND	0xE9	Send acknowledge frame when pending field set	SACKPEND	The ISACKPEND instruction immediately sends an acknowledge frame with the pending field set. The instruction waits for the radio to receive an acknowledgment before executing the next instruction.

Radio : Radio Registers

Table 48: Condition code for C

Condition code C	Description	Function
000	CCA is true	CCA = 1
001	Transmitting or Receiving packet	SFD = 1
010	CPU control true	CSPCTRL.CPU_CTRL=1
011	End of instruction memory	PC = 23
100	Register X=0	X = 0
101	Register Y=0	Y = 0
110	Register Z=0	Z = 0
111	Not used	-

14.35 Radio Registers

This section describes all RF registers used for control and status for the radio. The RF registers reside in XDATA memory space. Table 49 gives an overview of register

addresses while the remaining tables in this section describe each register. Refer also to section 3 for Register conventions.

Table 49 : Overview of RF registers

XDATA Address	Register name	Description
0xDF00-0xDF01	-	Reserved
0xDF02	MDMCTRL0H	Modem Control 0, high
0xDF03	MDMCTRL0L	Modem Control 0, low
0xDF04	MDMCTRL1H	Modem Control 1, high
0xDF05	MDMCTRL1L	Modem Control 1, low
0xDF06	RSSIH	RSSI and CCA Status and Control, high
0xDF07	RSSIL	RSSI and CCA Status and Control, low
0xDF08	SYNCWORDH	Synchronisation Word Control, high
0xDF09	SYNCWORDL	Synchronisation Word Control, low
0xDF0A	TXCTRLH	Transmit Control, high
0xDF0B	TXCTRL	Transmit Control, low
0xDF0C	RXCTRL0H	Receive Control 0, high
0xDF0D	RXCTRL0L	Receive Control 0, low
0xDF0E	RXCTRL1H	Receive Control 1, high
0xDF0F	RXCTRL1L	Receive Control 1, low
0xDF10	FSCTRLH	Frequency Synthesizer Control and Status, high
0xDF11	FSCTRL	Frequency Synthesizer Control and Status, low
0xDF12	CSPX	CSP X Data
0xDF13	CSPY	CSP Y Data
0xDF14	CSPZ	CSP Z Data
0xDF15	CSPCTRL	CSP Control
0xDF16	CSPT	CSP T Data
0xDF17	RFPWR	RF Power Control

Radio : Radio Registers

XDATA Address	Register name	Description
0xDF20	FSMTCH	Finite State Machine Time Constants, high
0xDF21	FSMTCL	Finite State Machine Time Constants, low
0xDF22	MANANDH	Manual AND Override, high
0xDF23	MANANDL	Manual AND Override, low
0xDF24	MANORH	Manual OR Override, high
0xDF25	MANORL	Manual OR Override, low
0xDF26	AGCCTRLH	AGC Control, high
0xDF27	AGCCTRL	AGC Control, low
0xDF28-0xDF38	-	Reserved
0xDF39	FSMSTATE	Finite State Machine State Status
0xDF3A	ADCTSTH	ADC Test, high
0xDF3B	ADCTSTL	ADC Test, low
0xDF3C	DACTSTH	DAC Test, high
0xDF3D	DACTSTL	DAC Test, low
0xDF3E	-	Reserved
0xDF3F	-	Reserved
0xDF40	-	Reserved
0xDF41	-	Reserved
0xDF43	IEEE_ADDR0	IEEE Address 0 (LSB)
0xDF44	IEEE_ADDR1	IEEE Address 1
0xDF45	IEEE_ADDR2	IEEE Address 2
0xDF46	IEEE_ADDR3	IEEE Address 3
0xDF47	IEEE_ADDR4	IEEE Address 4
0xDF48	IEEE_ADDR5	IEEE Address 5
0xDF49	IEEE_ADDR6	IEEE Address 6
0xDF4A	IEEE_ADDR7	IEEE Address 7 (MSB)
0xDF4B	PANIDH	PAN Identifier, high
0xDF4C	PANIDL	PAN Identifier, low
0xDF4D	SHORTADDRH	Short Address, high
0xDF4E	SHORTADDRL	Short Address, low
0xDF4F	IOCFG0	I/O Configuration 0
0xDF50	IOCFG1	I/O Configuration 1
0xDF51	IOCFG2	I/O Configuration 2
0xDF52	IOCFG3	I/O Configuration 3
0xDF53	RXFIFOCNT	RX FIFO Count

Radio : Radio Registers

XDATA Address	Register name	Description
0xDF54	FSMTC1	Finite State Machine Control
0xDF55-0xDF5F	-	Reserved
0xDF60	CHVER	Chip Version
0xDF61	CHIPID	Chip Identification
0xDF62	RFSTATUS	RF Status
0xDF63	-	Reserved
0xDF64	IRQSRC	RF Interrupt Source

The RF registers shown in Table 50 are reserved for test purposes. The values for these registers should be obtained from SmartRF® Studio (see section 16 on page 202) and should not be changed.

**Table 50 : Overview of RF test registers**

XDATA Address	Register name	Reset value
0xDF28	AGCTST0H	0x36
0xDF29	AGCTST0L	0x49
0xDF2A	AGCTST1H	0x08
0xDF2B	AGCTST1L	0x54
0xDF2C	AGCTST2H	0x09
0xDF2D	AGCTST2L	0x0A
0xDF2E	FSTST0H	0x10
0xDF2F	FSTST0L	0x00
0xDF30	FSTST1H	0x40
0xDF31	FSTST1L	0x32
0xDF32	FSTST2H	0x20
0xDF33	FSTST2L	0x00
0xDF34	FSTST3H	0x92
0xDF35	FSTST3L	0xDD
0xDF37	RXBPFTSTH	0x00
0xDF38	RXBPFTSTL	0x00
0xDF3F	TOPTST	0x10
0xDF40	RESERVEDH	0x00
0xDF41	RESERVEDL	0x00

Radio : Radio Registers

**MDMCTRL0H (0xDF02)**

Bit	Name	Reset	R/W	Function
7:6	FRAMET_FILT	00	R/W	<p>These bits are used to perform special operations on the frame type field of a received packet. These operations do not influence the packet that is written to the RXFIFO.</p> <p>00 : Leave frame type as it is.            01 : Invert MSB of frame type.            10 : Set MSB of frame type to 0.            11 : Set MSB of frame type to 1.</p> <p>For IEEE 802.15.4 compliant operation these bits should always be set to 00.</p>
5	RESERVED_FRAME_MODE	0	R/W	<p>Mode for accepting reserved IEEE 802.15.4 frame types when address recognition is enabled (MDMCTRL0.ADDR_DECODE = 1).</p> <p>0 : Reserved frame types (100, 101, 110, 111) are rejected by address recognition.            1 : Reserved frame types (100, 101, 110, 111) are always accepted by address recognition. No further address decoding is done.</p> <p>When address recognition is disabled (MDMCTRL0.ADDR_DECODE = 0), all frames are received and RESERVED_FRAME_MODE is don't care.</p> <p>For IEEE 802.15.4 compliant operation these bits should always be set to 00.</p>
4	PAN_COORDINATOR	0	R/W	<p>PAN Coordinator enable. Used for filtering packets with no destination address, as specified in section 7.5.6.2 in 802.15.4 [1]</p> <p>0 : Device is not a PAN Coordinator            1 : Device is a PAN Coordinator</p>
3	ADDR_DECODE	1	R/W	<p>Hardware Address decode enable.</p> <p>0 : Address decoding is disabled            1 : Address decoding is enabled</p>
2:0	CCA_HYST[2:0]	010	R/W	<p>CCA Hysteresis in dB, values 0 through 7 dB</p>

Radio : Radio Registers

### MDMCTRL0L (0xDF03)

Bit	Name	Reset	R/W	Description
7:6	CCA_MODE[1:0]	11	R/W	Clear Channel Assessment mode select. 00 : Reserved 01 : CCA=1 when RSSI < CCA_THR-CCA_HYST CCA=0 when RSSI >= CCA_THR 10 : CCA=1 when not receiving a packet 11 : CCA=1 when RSSI < CCA_THR-CCA_HYST and not receiving a packet CCA=0 when RSSI >= CCA_THR or receiving a packet
5	AUTOCRC	1	R/W	In packet mode a CRC-16 (ITU-T) is calculated and is transmitted after the last data byte in TX. In RX CRC is calculated and checked for validity.
4	AUTOACK	0	R/W	If AUTOACK is enabled, all packets accepted by address recognition with the acknowledge request flag set and a valid CRC are acknowledged 12 symbol periods after being received if MDMCTRL1H.SLOTTED_ACK = 0. Acknowledgment is at the beginning of the first backoff slot more than 12 symbol periods after the end of the received frame if the MDMCTRL1H.SLOTTED_ACK = 1 0 : AUTOACK disabled 1 : AUTOACK enabled
3:0	PREAMBLE_LENGTH[3:0]	0010	R/W	The number of preamble bytes (2 zero-symbols) to be sent in TX mode prior to the SYNCWORD. The reset value of 0010 is compliant with IEEE 802.15.4, since the 4 <sup>th</sup> zero byte is included in the SYNCWORD. 0000 : 1 leading zero bytes (not recommended) 0001 : 2 leading zero bytes (not recommended) 0010 : 3 leading zero bytes (IEEE 802.15.4 compliant) 0011 : 4 leading zero bytes ... 1111 : 16 leading zero bytes

### MDMCTRL1H (0xDF04)

Bit	Name	Reset	R/W	Description
7	SLOTTED_ACK	0	R/W	SLOTTED_ACK defines the timing of automatically transmitted acknowledgment frames. 0 : The acknowledgment frame is transmitted 12 symbol periods after the incoming frame. 1 : The acknowledgment frame is transmitted between 12 and 30 symbol periods after the incoming frame. The timing is defined such that there is an integer number of 20-symbol periods between the received and the transmitted SFDs. This may be used to transmit slotted acknowledgment frames in a beacon enabled network.
6	-	0	R/W	Reserved
5	CORR_THR_SFD	1	R/W	CORR_THR_SFD defines the level at which the CORR_THR correlation threshold is used to filter out received frames. 0 : Same filtering as CC2420, should be combined with a CORR_THR of 0x14 1 : More extensive filtering is performed, which will result in less false frame detections e.g. caused by noise.
4:0	CORR_THR[4:0]	0x10	R/W	Demodulator correlator threshold value, required before SFD search.

Radio : Radio Registers

### MDMCTRL1L (0xDF05)

Bit	Name	Reset	R/W	Description
7:6	-	00	R0	Reserved, read as 0.
5	DEMOD_AVG_MODE	0	R/W	DC average filter behavior. 0 : Lock DC level to be removed after preamble match 1 : Continuously update DC average level.
4	MODULATION_MODE	0	R/W	Set one of two RF modulation modes for RX / TX 0 : IEEE 802.15.4 compliant mode 1 : Reversed phase, non-IEEE compliant (could be used to set up a system which will not receive 802.15.4 packets)
3:2	TX_MODE[1:0]	00	R/W	Set test modes for TX 00 : Normal operation, transmit TXFIFO 01 : Serial mode, use transmit data on serial interface, infinite transmission. 10 : TXFIFO looping ignore underflow in TXFIFO and read cyclic, infinite transmission. 11 : Send random data from CRC, infinite transmission.
1:0	RX_MODE[1:0]	00	R/W	Set test mode of RX 00 : Normal operation, use RXFIFO 01 : Receive serial mode, output received data on pins. Infinite RX. 10 : RXFIFO looping ignore overflow in RXFIFO and write cyclic, infinite reception. 11 : Reserved

### RSSIH (0xDF06)

Bit	Name	Reset	R/W	Description
7:0	CCA_THR[7:0]	0xE0	R/W	Clear Channel Assessment threshold value, signed number in 2's complement for comparison with the RSSI. The unit is 1 dB, offset is TBD [depends on the absolute gain of the RX chain, including external components and should be measured]. The CCA signal goes high when the received signal is below this value. The reset value is in the range of -70 dBm.

Radio : Radio Registers

### RSSIL (0xDF07)

Bit	Name	Reset	R/W	Description
7:0	RSSI_VAL[7:0]	0x80	R	RSSI estimate on a logarithmic scale, signed number in 2's complement.  Unit is 1 dB, offset is TBD [depends on the absolute gain of the RX chain, including external components, and should be measured]. The RSSI value is averaged over 8 symbol periods.

### SYNCWORDH (0xDF08)

Bit	Name	Reset	R/W	Description
7:0	SYNCWORD[15:8]	0xA7	R/W	Synchronization word. The SYNCWORD is processed from the least significant nibble (F at reset) to the most significant nibble (A at reset).  SYNCWORD is used both during modulation (where 0xF's are replaced with 0x0's) and during demodulation (where 0xF's are not required for frame synchronization). In reception an implicit zero is required before the first symbol required by SYNCWORD.  The reset value is compliant with IEEE 802.15.4.

### SYNCWORDL (0xDF09)

Bit	Name	Reset	R/W	Description
7:0	SYNCWORD[7:0]	0x0F	R/W	Synchronization word. The SYNCWORD is processed from the least significant nibble (F at reset) to the most significant nibble (A at reset).  SYNCWORD is used both during modulation (where 0xF's are replaced with 0x0's) and during demodulation (where 0xF's are not required for frame synchronization). In reception an implicit zero is required before the first symbol required by SYNCWORD.  The reset value is compliant with IEEE 802.15.4.

### TXCTRLH (0xDF0A)

Bit	Name	Reset	R/W	Description
7:6	TXMIXBUF_CUR[1:0]	10	R/W	TX mixer buffer bias current. 00 : 690 uA 01 : 980 uA 10 : 1.16 mA (nominal) 11 : 1.44 mA
5	TX_TURNAROUND	1	R/W	Sets the wait time after STXON before transmission is started. 0 : 8 symbol periods (128 us) 1 : 12 symbol periods (192 us)
4:3	TXMIX_CAP_ARRAY[1:0]	0	R/W	Selects varactor array settings in the transmit mixers.
2:1	TXMIX_CURRENT[1:0]	0	R/W	Transmit mixers current: 00 : 1.72 mA 01 : 1.88 mA 10 : 2.05 mA 11 : 2.21 mA
0	PA_DIFF	1	R/W	Power Amplifier (PA) output select. Selects differential or single-ended PA output. 0 : Single-ended output 1 : Differential output

Radio : Radio Registers

### TXCTRL (0xDF0B)

Bit	Name	Reset	R/W	Description
7:5	PA_CURRENT[2:0]	011	R/W	Current programming of the PA 000 : -3 current adjustment 001 : -2 current adjustment 010 : -1 current adjustment 011 : Nominal setting 100 : +1 current adjustment 101 : +2 current adjustment 110 : +3 current adjustment 111 : +4 current adjustment
4:0	PA_LEVEL[4:0]	0x1F	R/W	Output PA level. (~0 dBm)

### RXCTRL0H (0xDF0C)

Bit	Name	Reset	R/W	Description
7:6	-	00	R0	Reserved, read as 0.
5:4	RXMIXBUF_CUR[1:0]	01	R/W	RX mixer buffer bias current. 00 : 690 uA 01 : 980 uA (nominal) 10 : 1.16 mA 11 : 1.44 mA
3:2	HIGH_LNA_GAIN[1:0]	0	R/W	Controls current in the LNA gain compensation branch in AGC High gain mode. 00 : Compensation disabled 01 : 100 uA compensation current 10 : 300 uA compensation current (Nominal) 11 : 1000 uA compensation current
1:0	MED_LNA_GAIN[1:0]	10	R/W	Controls current in the LNA gain compensation branch in AGC Med gain mode.

### RXCTRL0L (0xDF0D)

Bit	Name	Reset	R/W	Description
7:6	LOW_LNA_GAIN[1:0]	11	R/W	Controls current in the LNA gain compensation branch in AGC Low gain mode
5:4	HIGH_LNA_CURRENT[1:0]	10	R/W	Controls main current in the LNA in AGC High gain mode 00 : 240 uA LNA current (x2) 01 : 480 uA LNA current (x2) 10 : 640 uA LNA current (x2) 11 : 1280 uA LNA current (x2)
3:2	MED_LNA_CURRENT[1:0]	01	R/W	Controls main current in the LNA in AGC Med gain mode
1:0	LOW_LNA_CURRENT[1:0]	01	R/W	Controls main current in the LNA in AGC Low gain mode

Radio : Radio Registers

### RXCTRL1H (0xDF0E)

Bit	Name	Reset	R/W	Description
7:6	-	0	R0	Reserved, read as 0.
5	RXBPF_LOCUR	1	R/W	Controls reference bias current to RX band-pass filters: 0 : 4 $\mu$ A 1 : 3 $\mu$ A (Default)
4	RXBPF_MIDCUR	0	R/W	Controls reference bias current to RX band-pass filters: 0 : 4 $\mu$ A (Default) 1 : 3.5 $\mu$ A
3	LOW_LOWGAIN	1	R/W	LNA low gain mode setting in AGC low gain mode.
2	MED_LOWGAIN	0	R/W	LNA low gain mode setting in AGC medium gain mode.
1	HIGH_HGM	1	R/W	RX Mixers high gain mode setting in AGC high gain mode.
0	MED_HGM	0	R/W	RX Mixers high gain mode setting in AGC medium gain mode.

### RXCTRL1L (0xDF0F)

Bit	Name	Reset	R/W	Description
7:6	LNA_CAP_ARRAY[1:0]	01	R/W	Selects varactor array setting in the LNA 00 : OFF 01 : 0.1 pF (x2) (Nominal) 10 : 0.2 pF (x2) 11 : 0.3 pF (x2)
5:4	RXMIX_TAIL[1:0]	01	R/W	Control of the receiver mixers output current. 00 : 12 $\mu$ A 01 : 16 $\mu$ A (Nominal) 10 : 20 $\mu$ A 11 : 24 $\mu$ A
3:2	RXMIX_VCM[1:0]	01	R/W	Controls VCM level in the mixer feedback loop 00 : 8 $\mu$ A mixer current 01 : 12 $\mu$ A mixer current (Nominal) 10 : 16 $\mu$ A mixer current 11 : 20 $\mu$ A mixer current
1:0	RXMIX_CURRENT[1:0]	10	R/W	Controls current in the mixer 00 : 360 $\mu$ A mixer current (x2) 01 : 720 $\mu$ A mixer current (x2) 10 : 900 $\mu$ A mixer current (x2) (Nominal) 11 : 1260 $\mu$ A mixer current (x2)

### FSCTRLH (0xDF10)

Bit	Name	Reset	R/W	Description
7 : 6	LOCK_THR[1:0]	01	R/W	Number of consecutive reference clock periods with successful sync windows required to indicate lock: 00 : 64 01 : 128 10 : 256 11 : 512
5	CAL_DONE	0	R	Frequency synthesizer calibration done. 0 : Calibration not performed since the last time the FS was turned on. 1 : Calibration performed since the last time the FS was turned on.
4	CAL_RUNNING	0	R	Calibration status, '1' when calibration in progress.
3	LOCK_LENGTH	0	R/W	LOCK_WINDOW pulse width: 0: 2 CLK_PRE periods 1: 4 CLK_PRE periods
2	LOCK_STATUS	0	R	PLL lock status 0 : PLL is not in lock 1 : PLL is in lock
1 : 0	FREQ[9 : 8]	01  (2405 MHz)	R/W	Frequency control word. Used directly in TX, in RX the LO frequency is automatically set 2 MHz below the RF frequency.  $\text{Frequency division} = \frac{2048 + \text{FREQ}[9 : 0]}{4} \Leftrightarrow$ $f_{RF} = (2048 + \text{FREQ}[9 : 0]) \text{ MHz}$ $f_{LO} = (2048 + \text{FREQ}[9 : 0] - 2 \cdot \text{RXEN}) \text{ MHz}$

### FSCTRLH (0xDF11)

Bit	Name	Reset	R/W	Description
7 : 0	FREQ[7 : 0]	0x65  (2405 MHz)	R/W	Frequency control word. Used directly in TX, in RX the LO frequency is automatically set 2 MHz below the RF frequency.  $\text{Frequency division} = \frac{2048 + \text{FREQ}[9 : 0]}{4} \Leftrightarrow$ $f_{RF} = (2048 + \text{FREQ}[9 : 0]) \text{ MHz}$ $f_{LO} = (2048 + \text{FREQ}[9 : 0] - 2 \cdot \text{RXEN}) \text{ MHz}$

### CSPT (0xDF16)

Bit	Name	Reset	R/W	Description
7 : 0	CSPT	0x00	R/W	CSP T Data register. Contents is decremented each time MAC Timer overflows while CSP program is running. CSP program stops when is about to count to 0. Setting T=0xFF disables decrement function.

### CSPX (0xDF12)

Bit	Name	Reset	R/W	Description
7 : 0	CSPX	0x00	R/W	CSP X Data register. Used by CSP WAITX, RANDXY and conditional instructions

Radio : Radio Registers

### CSPY (0xDF13)

Bit	Name	Reset	R/W	Description
7:0	CSPY	0x00	R/W	CSP Y Data register. Used by CSP INCY, DECY, INCMAXY, RANDXY and conditional instructions

### CSPZ (0xDF14)

Bit	Name	Reset	R/W	Description
7:0	CSPZ	0x00	R/W	CSP Z Data register. Used by CSP DECZ and conditional instructions

### CSPCTRL (0xDF15)

Bit	Name	Reset	R/W	Description
7:1	-	0x00	R0	Reserved, read as 0
0	CPU_CTRL	0	R/W	CSP CPU control input. Used by CSP conditional instructions.

### RFPWR (0xDF17)

Bit	Name	Reset	R/W	Description																											
7:5	-	0	R0	Reserved, read as 0.																											
4	ADI_RADIO_PD	1	R	ADI_RADIO_PD is a delayed version of RREG_RADIO_PD. The delay is set by RREG_DELAY[2:0]. When ADI_RADIO_PD is 0, all analog modules in the radio are set in power down. ADI_RADIO_PD is read only.																											
3	RREG_RADIO_PD	1	R/W	Power down of the voltage regulator to the analog part of the radio. This signal is used to enable or disable the analog radio. 0 : Power up 1 : Power down																											
2:0	RREG_DELAY[2:0]	100	R/W	Delay value used in power-on for voltage regulator <table border="1" style="margin-left: 20px;"> <thead> <tr> <th>VREG_DELAY[2:0]</th> <th>Delay</th> <th>Units</th> </tr> </thead> <tbody> <tr><td>000</td><td>0</td><td>µs</td></tr> <tr><td>001</td><td>31</td><td>µs</td></tr> <tr><td>010</td><td>63</td><td>µs</td></tr> <tr><td>011</td><td>125</td><td>µs</td></tr> <tr><td>100</td><td>250</td><td>µs</td></tr> <tr><td>101</td><td>500</td><td>µs</td></tr> <tr><td>110</td><td>1000</td><td>µs</td></tr> <tr><td>111</td><td>2000</td><td>µs</td></tr> </tbody> </table>	VREG_DELAY[2:0]	Delay	Units	000	0	µs	001	31	µs	010	63	µs	011	125	µs	100	250	µs	101	500	µs	110	1000	µs	111	2000	µs
VREG_DELAY[2:0]	Delay	Units																													
000	0	µs																													
001	31	µs																													
010	63	µs																													
011	125	µs																													
100	250	µs																													
101	500	µs																													
110	1000	µs																													
111	2000	µs																													

Radio : Radio Registers

### FSMTCH (0xDF20)

Bit	Name	Reset	R/W	Description
7:5	TC_RXCHAIN2RX[2:0]	011	R/W	The time in 5 us steps between the time the RX chain is enabled and the demodulator and AGC is enabled. The RX chain is started when the band pass filter has been calibrated (after 6.5 symbol periods).
4:2	TC_SWITCH2TX[2:0]	110	R/W	The time in advance the RXTX switch is set high, before enabling TX. Unit is $\mu$ s.
1:0	TC_PAON2TX[3:2]	10	R/W	The time in advance the PA is powered up before enabling TX. Unit is $\mu$ s.

### FSMTCL (0xDF21)

Bit	Name	Reset	R/W	Description
7:6	TC_PAON2TX[1:0]	10	R/W	The time in advance the PA is powered up before enabling TX. Unit is $\mu$ s.
5:3	TC_TXEND2SWITCH[2:0]	010	R/W	The time after the last chip in the packet is sent, and the rtx switch is disabled. Unit is $\mu$ s.
2:0	TC_TXEND2PAOFF[2:0]	100	R/W	The time after the last chip in the packet is sent, and the PA is set in power-down. Also the time at which the modulator is disabled. Unit is $\mu$ s.

### MANANDH (0xDF22)

Bit	Name	Reset	R/W	Description
7	VGA_RESET_N	1	R/W	The VGA_RESET_N signal is used to reset the peak detectors in the VGA in the RX chain.
6	BIAS_PD	1	R/W	Reserved, read as 0
5	BALUN_CTRL	1	R/W	The BALUN_CTRL signal controls whether the PA should receive its required external biasing (1) or not (0) by controlling the RX/TX output switch.
4	RXTX	1	R/W	RXTX signal: controls whether the LO buffers (0) or PA buffers (1) should be used.
3	PRE_PD	1	R/W	Powerdown of prescaler.
2	PA_N_PD	1	R/W	Powerdown of PA (negative path).
1	PA_P_PD	1	R/W	Powerdown of PA (positive path). When PA_N_PD=1 and PA_P_PD=1 the up conversion mixers are in powerdown.
0	DAC_LPF_PD	1	R/W	Powerdown of TX DACs.

Radio : Radio Registers

### MANANDL (0xDF23)

Bit	Name	Reset	R/W	Description
7	-	0	R0	Reserved, read as 0
6	RXBPF_CAL_PD	1	R/W	Powerdown control of complex band pass receive filter calibration oscillator.
5	CHP_PD	1	R/W	Powerdown control of charge pump.
4	FS_PD	1	R/W	Powerdown control of VCO, I/Q generator, LO buffers.
3	ADC_PD	1	R/W	Powerdown control of the ADCs.
2	VGA_PD	1	R/W	Powerdown control of the VGA.
1	RXBPF_PD	1	R/W	Powerdown control of complex band pass receive filter.
0	LNAMIX_PD	1	R/W	Powerdown control of LNA, down conversion mixers and front-end bias.

### MANORH (0xDF24)

Bit	Name	Reset	R/W	Description
7	VGA_RESET_N	0	R/W	The VGA_RESET_N signal is used to reset the peak detectors in the VGA in the RX chain.
6	BIAS_PD	0	R/W	Global Bias power down (1)
5	BALUN_CTRL	0	R/W	The BALUN_CTRL signal controls whether the PA should receive its required external biasing (1) or not (0) by controlling the RX/TX output switch.
4	RXTX	0	R/W	RXTX signal: controls whether the LO buffers (0) or PA buffers (1) should be used.
3	PRE_PD	0	R/W	Powerdown of prescaler.
2	PA_N_PD	0	R/W	Powerdown of PA (negative path).
1	PA_P_PD	0	R/W	Powerdown of PA (positive path). When PA_N_PD=1 and PA_P_PD=1 the up conversion mixers are in powerdown.
0	DAC_LPF_PD	0	R/W	Powerdown of TX DACs.

### MANORL (0xDF25)

Bit	Name	Reset	R/W	Description
7	-	0	R0	Reserved, read as 0
6	RXBPF_CAL_PD	0	R/W	Powerdown control of complex band pass receive filter calibration oscillator.
5	CHP_PD	0	R/W	Powerdown control of charge pump.
4	FS_PD	0	R/W	Powerdown control of VCO, I/Q generator, LO buffers.
3	ADC_PD	0	R/W	Powerdown control of the ADCs.
2	VGA_PD	0	R/W	Powerdown control of the VGA.
1	RXBPF_PD	0	R/W	Powerdown control of complex band pass receive filter.
0	LNAMIX_PD	0	R/W	Powerdown control of LNA, down conversion mixers and front-end bias.

Radio : Radio Registers

### AGCCTRLH (0xDF26)

Bit	Name	Reset	R/W	Description
7	VGA_GAIN_OE	0	R/W	Use the VGA_GAIN value during RX instead of the AGC value.
6:0	VGA_GAIN[6:0]	0x7F	R/W	When written, VGA manual gain override value; when read, the currently used VGA gain setting.

### AGCTRLL (0xDF27)

Bit	Name	Reset	R/W	Description
7:4	-	0	R0	Reserved, read as 0.
3:2	LNAMIX_GAINMODE_O [1:0]	00	R/W	LNA / Mixer Gain mode override setting 00 : Gain mode is set by AGC algorithm 01 : Gain mode is always low-gain 10 : Gain mode is always med-gain 11 : Gain mode is always high-gain
1:0	LNAMIX_GAINMODE[1:0]	00	R	Status bit, defining the currently selected gain mode selected by the AGC or overridden by the LNAMIX_GAINMODE_O setting. Note that this value is updated by HW and may have changed between reset and when read.

### FSMSTATE (0xDF39)

Bit	Name	Reset	R/W	Description
7:6	-	0	R0	Reserved, read as 0.
5:0	FSM_FFCTRL_STATE[5:0]	-	R	Gives the current state of the FIFO and Frame Control (FFCTRL) finite state machine.

### ADCTSTH (0xDF3A)

Bit	Name	Reset	R/W	Function
7	ADC_CLOCK_DISABLE	0	R/W	ADC Clock Disable 0 : Clock enabled when ADC enabled 1 : Clock disabled, even if ADC is enabled
6:0	ADC_I[6:0]	-	R	Returns the current ADC I-branch value.

### ADCTSTL (0xDF3B)

Bit	Name	Reset	R/W	Function
7	-	0	R0	Reserved, read as 0.
6:0	ADC_Q[6:0]	-	R	Returns the current ADC Q-branch value.

Radio : Radio Registers

### DACTSTH (0xDF3C)

Bit	Name	Reset	R/W	Description
7	-	0	R0	Reserved, read as 0.
6:4	DAC_SRC[2:0]	000	R/W	<p>The TX DACs data source is selected by DAC_SRC according to:</p> <ul style="list-style-type: none"> <li>000 : Normal operation (from modulator).</li> <li>001 : The DAC_I_O and DAC_Q_O override values below.-</li> <li>010 : From ADC, most significant bits</li> <li>011 : I/Q after digital down mix and channel filtering.</li> <li>100 : Full-spectrum White Noise (from CRC)</li> <li>101 : From ADC, least significant bits</li> <li>110 : RSSI / Cordic Magnitude Output</li> <li>111 : HSSD module.</li> </ul> <p>This feature will often require the DACs to be manually turned on in MANOVR and PAMTST.ATESTMOD_MODE=4.</p>
3:0	DAC_I_O[5:2]	000	R/W	I-branch DAC override value.

### DACTSTL (0xDF3D)

Bit	Name	Reset	R/W	Description
7:6	DAC_I_O[1:0]	00	R/W	I-branch DAC override value.
5:0	DAC_Q_O[5:0]	0x00	R/W	Q-branch DAC override value.

### IEEE\_ADDR0 (0xDF43)

Bit	Name	Reset	R/W	Description
7:0	IEEE_ADDR0[7:0]	0x00	R/W	IEEE ADDR byte 0 (LSB)

### IEEE\_ADDR1 (0xDF44)

Bit	Name	Reset	R/W	Description
7:0	IEEE_ADDR1[7:0]	0x00	R/W	IEEE ADDR byte 1

### IEEE\_ADDR2 (0xDF45)

Bit	Name	Reset	R/W	Description
7:0	IEEE_ADDR2[7:0]	0x00	R/W	IEEE ADDR byte 2

### IEEE\_ADDR3 (0xDF46)

Bit	Name	Reset	R/W	Description
7:0	IEEE_ADDR3[7:0]	0x00	R/W	IEEE ADDR byte 3

### IEEE\_ADDR4 (0xDF47)

Bit	Name	Reset	R/W	Description
7:0	IEEE_ADDR4[7:0]	0x00	R/W	IEEE ADDR byte 4

Radio : Radio Registers

### IEEE\_ADDR5 (0xDF48)

Bit	Name	Reset	R/W	Description
7:0	IEEE_ADDR5[7:0]	0x00	R/W	IEEE ADDR byte 5

### IEEE\_ADDR6 (0xDF49)

Bit	Name	Reset	R/W	Description
7:0	IEEE_ADDR6[7:0]	0x00	R/W	IEEE ADDR byte 6

### IEEE\_ADDR7 (0xDF4A)

Bit	Name	Reset	R/W	Description
7:0	IEEE_ADDR7[7:0]	0x00	R/W	IEEE ADDR byte 7 (MSB)

### PANIDH (0xDF4B)

Bit	Name	Reset	R/W	Description
7:0	PANIDH[7:0]	0x00	R/W	PAN identifier high byte

### PANIDL (0xDF4C)

Bit	Name	Reset	R/W	Description
7:0	PANIDL[7:0]	0x00	R/W	PAN identifier low byte

### SHORTADDRH (0xDF4D)

Bit	Name	Reset	R/W	Description
7:0	SHORTADDRH[7:0]	0x00	R/W	Short address high byte

### SHORTADDRL (0xDF4E)

Bit	Name	Reset	R/W	Description
7:0	SHORTADDRL[7:0]	0x00	R/W	Short address low byte

### IOCFG0 (0xDF4F)

Bit	Name	Reset	R/W	Description
7	-	0	R0	Reserved, read as 0.
6:0	FIFOP_THR[6:0]	0x40	R/W	Sets the number of bytes in RXFIFO that is required for FIFOP to go high.

Radio : Radio Registers

### IOCFG1 (0xDF50)

Bit	Name	Reset	R/W	Description
7	-	0	R0	Reserved, read as 0.
6	OE_CCA	0	R/W	CCA is output on P1.7 when this bit is 1
5	IO_CCA_POL	0	R/W	Polarity of the IO_CCA signal. This bit is xor'ed with the internal CCA signal.
4:0	IO_CCA_SEL	00000	R/W	Multiplexer setting for the CCA signal. Must be 0x00 in order to output the CCA status.

### IOCFG2 (0xDF51)

Bit	Name	Reset	R/W	Description
7	-	0	R0	Reserved, read as 0.
6	OE_SFD	0	R/W	SFD is output on P1.6 when this bit is 1
5	IO_SFD_POL	0	R/W	Polarity of the IO_SFD signal. This bit is xor'ed with the internal SFD signal.
4:0	IO_SFD_SEL	00000	R/W	Multiplexer setting for the SFD signal. Must be 0x00 in order to output the SFD status

### IOCFG3 (0xDF52)

Bit	Name	Reset	R/W	Description
7:6	-	00	R0	Reserved, read as 0.
5:4	HSSD_SRC	00	R/W	Configures the HSSD interface. Only the first 4 settings (compared to CC2420) are used. 00 : Off 01 : Output AGC status (gain setting/peak detector status/accumulator value) 10 : Output ADC I and Q values 11 : Output I/Q after digital down mix and channel filtering
3	OE_FIFOP	0	R/W	FIFOP is output on P1.5 when this bit is 1.
2	IO_FIFOP_POL	0	R/W	Polarity of the IO_FIFOP signal. This bit is xor'ed with the internal FIFOP signal
1	OE_FIFO	0	R/W	FIFO is output on P1.4 when this bit is 1
0	IO_FIFO_POL	0	R/W	Polarity of the IO_FIFO signal. This bit is xor'ed with the internal FIFO signal

### RXFIFOCNT (0xDF53)

Bit	Name	Reset	R/W	Description
7:0	RXFIFOCNT[7:0]	0x00	R	Number of bytes in the RX FIFO

Radio : Radio Registers

### FSMTC1 (0xDF54)

Bit	Name	Reset	R/W	Description
7:6	-	00	R0	Reserved, read as 0.
5	ABORTRX_ON_SRXON	1	R/W	Abort RX when SRXON strobe is issued 0 : Packet reception is not aborted when SRXON is issued 1 : Packet reception is aborted when SRXON is issued
4	RX_INTERRUPTED	0	R	RX interrupted by strobe command This bit is cleared when the next strobe is detected. 0 : Strobe command detected 1 : Packet reception was interrupted by strobe command
3	AUTO_TX2RX_OFF	0	R/W	Automatically go to RX after TX. Applies to both data packets and ACK packets. 0 : Automatic RX after TX 1 : No automatic RX after TX
2	RX2RX_TIME_OFF	0	R/W	Turns off the 12 symbol timeout after packet reception has ended. Active high.
1	PENDING_OR	0	R/W	This bit is OR'ed with the pending bit from FFCTRL before it goes to the modulator.
0	ACCEPT_ACKPKT	1	R/W	Accept ACK packet control. 0 : Reject all ACK packets 1 : ACK packets are received

### CHVER (0xDF60)

Bit	Name	Reset	R/W	Description
7:0	VERSION[7:0]	0x03	R	Chip revision number. The relationship between the value in VERSION[7:0] and the die revision is as follows: 0x03 : Die revision D  The current number in VERSION[7:0] may not be consistent with past or future die revisions of this product

### CHIPID (0xDF61)

Bit	Name	Reset	R/W	Description
7:0	CHIPID[7:0]	0x85	R	Chip identification number. Always read as 0x85.

Radio : Radio Registers

### RFSTATUS (0xDF62)

Bit	Name	Reset	R/W	Description
7:5	-	000	R0	Reserved, read as 0.
4	TX_ACTIVE	0	R	TX active indicates transmission in progress 0 : TX inactive 1 : TX active
3	FIFO	0	R	RXFIFO data available 0 : No data available in RXFIFO 1 : One or more bytes available in RXFIFO
2	FIFOP	0	R	RXFIFO threshold flag 0 : Number of bytes in RXFIFO is less or equal threshold set by IOCFG0 . FIFOP_THR 1 : Number of bytes in RXFIFO is greater than threshold set by IOCFG0 . FIFOP_THR Note that if frame filtering/address recognition is enabled this bit is set only when the frame has passed filtering. This bit is also set when a complete frame has been received.
1	SFD	0	R	Start of Frame Delimiter status 0 : SFD inactive 1 : SFD active
0	CCA		R	Clear Channel Assessment

### IRQSRC (0xDF64)

Bit	Name	Reset	R/W	Description
7:1	-	0000000	R0	Reserved, read as 0.
0	TXACK	0	R/W	TX Acknowledge interrupt enable. 0 : RFIF interrupt is not set for acknowledge frames 1 : RFIF interrupt is set for acknowledge frames

## 15 Voltage Regulators

The **CC2430** includes two low drop-out voltage regulators. These are used to provide a 1.8 V power supply to the **CC2430** analog and digital power supplies.

*Note: It is recommended that the voltage regulators are not used to provide power to external circuits. This is because of limited power sourcing capability and due to noise considerations. External circuitry can be powered if they can be used when internal power consumption is low and can be set I PD mode when internal power consumption I high.*

### 15.1 Voltage Regulators Power-on

The analog voltage regulator is disabled by setting the RF register bit `RFPWR.RREG_RADIO_PD` to 1. When the analog voltage regulator is powered-on by clearing the `RFPWR.RREG_RADIO_PD` bit, there will be a delay before the regulator is enabled. This delay is programmable through the RF register. The interrupt flag `RFIF.IRQ_RREG_PD` is set when the delay

The analog voltage regulator input pin `AVDD_RREG` is to be connected to the unregulated 2.0 to 3.6 V power supply. The regulated 1.8 V voltage output to the analog parts, is available on the `RREG_OUT` pin. The digital regulator input pin `AVDD_DREG` is also to be connected to the unregulated 2.0 to 3.6 V power supply. The output of the digital regulator is connected internally within the **CC2430** to the digital power supply.

The voltage regulators require external components as described in section 10 on page 27.

has expired. The delayed power-on can also be observed by polling the RF register bit `RFPWR.ADI_RADIO_PD`.

The digital voltage regulator is disabled when the **CC2430** is placed in power modes PM2 or PM3 (see section 13.1). When the voltage regulators are disabled, register and RAM contents will be retained while the unregulated 2.0 to 3.6 power supply is present.

## 16 Evaluation Software

Texas Instruments provides users of **CC2430** with a software program, SmartRF® Studio, which may be used for radio performance and functionality evaluation. SmartRF® Studio runs

on Microsoft Windows 95/98 and Microsoft Windows NT/2000/XP. SmartRF® Studio can be downloaded from the Texas Instruments web page: <http://www.ti.com/lpw>

## 17 Register overview

ACC (0xE0) – Accumulator .....	43
ADCCFG (0xF2) – ADC Input Configuration .....	83
ADCCON1 (0xB4) – ADC Control 1 .....	131
ADCCON2 (0xB5) – ADC Control 2 .....	132
ADCCON3 (0xB6) – ADC Control 3 .....	133
ADCH (0xBB) – ADC Data High .....	131
ADCL (0xBA) – ADC Data Low .....	130
ADCTSTH (0xDF3A) .....	196
ADCTSTL (0xDF3B) .....	196
AGCCTRLH (0xDF26) .....	196
AGCTRLL (0xDF27) .....	196
B (0xF0) – B Register .....	43
CHIPID (0xDF61) .....	200
CHVER (0xDF60) .....	200
CLKCON (0xC6) – Clock Control .....	70
CSPCTRL (0xDF15) .....	193
CSPT (0xDF16) .....	192
CSPX (0xDF12) .....	192
CSPY (0xDF13) .....	193
CSPZ (0xDF14) .....	193
DACTSTH (0xDF3C) .....	197
DACTSTL (0xDF3D) .....	197
DMA0CFGH (0xD5) – DMA Channel 0 Configuration Address High Byte .....	97
DMA0CFGL (0xD4) – DMA Channel 0 Configuration Address Low Byte .....	97
DMAARM (0xD6) – DMA Channel Arm .....	96
DMAIRQ (0xD1) – DMA Interrupt Flag .....	98
DMAREQ (0xD7) – DMA Channel Start Request and Status .....	97
DPH0 (0x83) – Data Pointer 0 High Byte .....	42
DPH1 (0x85) – Data Pointer 1 High Byte .....	42
DPL0 (0x82) – Data Pointer 0 Low Byte .....	42
DPL1 (0x84) – Data Pointer 1 Low Byte .....	42
DPS (0x92) – Data Pointer Select .....	42
ENCCS (0xB3) – Encryption Control and Status .....	140
ENCDI (0xB1) – Encryption Input Data .....	140
ENCDO (0xB2) – Encryption Output Data .....	140
FADDRH (0xAD) – Flash Address High Byte .....	77
FADDRL (0xAC) – Flash Address Low Byte .....	77
FCTL (0xAE) – Flash Control .....	77
FSCTRLH (0xDF10) .....	192
FSCTRLL (0xDF11) .....	192
FSMSTATE (0xDF39) .....	196
FSMTC1 (0xDF54) .....	200
FSMTCH (0xDF20) .....	194
FSMTCL (0xDF21) .....	194
FWDATA (0xAF) – Flash Write Data .....	77
FWT (0xAB) – Flash Write Timing .....	77
IEEE_ADDR0 (0xDF43) .....	197
IEEE_ADDR1 (0xDF44) .....	197
IEEE_ADDR2 (0xDF45) .....	197
IEEE_ADDR3 (0xDF46) .....	197
IEEE_ADDR4 (0xDF47) .....	197
IEEE_ADDR5 (0xDF48) .....	198
IEEE_ADDR6 (0xDF49) .....	198
IEEE_ADDR7 (0xDF4A) .....	198
IEN0 (0xA8) – Interrupt Enable 0 .....	52
IEN2 (0x9A) – Interrupt Enable 2 .....	53
IOCFG0 (0xDF4F) .....	198
IOCFG1 (0xDF50) .....	199

IOCFG2 (0xDF51).....	199
IOCFG3 (0xDF52).....	199
IP0 (0xA9) – Interrupt Priority 0 .....	58
IP1 (0xB9) – Interrupt Priority 1 .....	57
IRCON (0xC0) – Interrupt Flags 4 .....	56
IRCON2 (0xE8) – Interrupt Flags 5.....	57
IRQSRC (0xDF64) .....	201
MANANDH (0xDF22).....	194
MANANDL (0xDF23).....	195
MANORH (0xDF24) .....	195
MANORL (0xDF25).....	195
MDMCTRL0H (0xDF02).....	186
MDMCTRL0L (0xDF03) .....	187
MDMCTRL1H (0xDF04).....	187
MDMCTRL1L (0xDF05).....	188
MEMCTR (0xC7) – Memory Arbiter Control .....	41
MPAGE (0x93) – Memory Page Select .....	40
P0 (0x80) – Port 0 .....	82
P0DIR (0xFD) – Port 0 Direction.....	84
P0IFG (0x89) – Port 0 Interrupt Status Flag .....	86
P0INP (0x8F) – Port 0 Input Mode.....	85
P0SEL (0xF3) – Port 0 Function Select .....	83
P1 (0x90) – Port 1 .....	82
P1DIR (0xFE) – Port 1 Direction.....	84
P1IEN (0x8D) – Port 1 Interrupt Mask .....	87
P1IFG (0x8A) – Port 1 Interrupt Status Flag.....	86
P1INP (0xF6) – Port 1 Input Mode.....	85
P1SEL (0xF4) – Port 1 Function Select .....	83
P2 (0xA0) – Port 2.....	83
P2DIR (0xFF) – Port 2 Direction .....	85
P2IFG (0x8B) – Port 2 Interrupt Status Flag.....	86
P2INP (0xF7) – Port 2 Input Mode.....	85
P2SEL (0xF5) – Port 2 Function Select .....	84
PANIDH (0xDF4B) .....	198
PANIDL (0xDF4C).....	198
PCON (0x87) – Power Mode Control.....	67
PERCFG (0xF1) – Peripheral Control.....	83
PICTL (0x8C) – Port Interrupt Control .....	87
PSW (0xD0) – Program Status Word .....	43
RFD (0xD9) – RF Data.....	157
RFIF (0xE9) – RF Interrupt Flags .....	156
RFIM (0x91) – RF Interrupt Mask .....	157
RFPWR (0xDF17).....	193
RFSTATUS (0xDF62) .....	201
RNDH (0xBD) – Random Number Generator Data High Byte .....	135
RNDL (0xBC) – Random Number Generator Data Low Byte.....	135
RSSIH (0xDF06) .....	188
RXCTRL0H (0xDF0C).....	190
RXCTRL0L (0xDF0D) .....	190
RXCTRL1H (0xDF0E).....	191
RXCTRL1L (0xDF0F).....	191
RXFIFOCNT (0xDF53).....	199
S0CON (0x98) – Interrupt Flags 2 .....	55
S1CON (0x9B) – Interrupt Flags 3.....	55
SHORTADDRH (0xDF4D) .....	198
SHORTADDRL (0xDF4E).....	198
SLEEP (0xBE) – Sleep Mode Control.....	67
SP (0x81) – Stack Pointer.....	44
ST0 (0x95) – Sleep Timer 0 .....	127
ST1 (0x96) – Sleep Timer 1 .....	126

ST2 (0x97) – Sleep Timer 2 .....	126
SYNCWORDH (0xDF08) .....	189
SYNCWORDL (0xDF09) .....	189
T1CC0H (0xDB) – Timer 1 Channel 0 Capture/Compare Value High .....	107
T1CC0L (0xDA) – Timer 1 Channel 0 Capture/Compare Value Low .....	107
T1CC1H (0xDD) – Timer 1 Channel 1 Capture/Compare Value High .....	108
T1CC1L (0xDC) – Timer 1 Channel 1 Capture/Compare Value Low .....	108
T1CC2H (0xDF) – Timer 1 Channel 2 Capture/Compare Value High .....	109
T1CC2L (0xDE) – Timer 1 Channel 2 Capture/Compare Value Low .....	109
T1CCTL0 (0xE5) – Timer 1 Channel 0 Capture/Compare Control .....	107
T1CCTL1 (0xE6) – Timer 1 Channel 1 Capture/Compare Control .....	108
T1CCTL2 (0xE7) – Timer 1 Channel 2 Capture/Compare Control .....	109
T1CNTH (0xE3) – Timer 1 Counter High .....	106
T1CNTL (0xE2) – Timer 1 Counter Low .....	106
T1CTL (0xE4) – Timer 1 Control and Status .....	106
T2CAPHPH (0xA5) – Timer 2 Period High Byte .....	115
T2CAPLPL (0xA4) – Timer 2 Period Low Byte .....	115
T2CMP (0x94) – Timer 2 Compare Value .....	114
T2CNF (0xC3) – Timer 2 Configuration .....	113
T2OF0 (0xA1) – Timer 2 Overflow Count 0 .....	115
T2OF1 (0xA2) – Timer 2 Overflow Count 1 .....	114
T2OF2 (0xA3) – Timer 2 Overflow Count 2 .....	114
T2PEROF0 (0x9C) – Timer 2 Overflow Capture/Compare 0 .....	116
T2PEROF1 (0x9D) – Timer 2 Overflow Capture/Compare 1 .....	115
T2PEROF2 (0x9E) – Timer 2 Overflow Capture/Compare 2 .....	115
T2THD (0xA7) – Timer 2 Timer Value High Byte .....	114
T2TLD (0xA6) – Timer 2 Timer Value Low Byte .....	114
T3CC0 (0xCD) – Timer 3 Channel 0 Compare Value .....	120
T3CC1 (0xCF) – Timer 3 Channel 1 Compare Value .....	121
T3CCTL0 (0xCC) – Timer 3 Channel 0 Compare Control .....	120
T3CCTL1 (0xCE) – Timer 3 Channel 1 Compare Control .....	121
T3CNT (0xCA) – Timer 3 Counter .....	118
T3CTL (0xCB) – Timer 3 Control .....	119
T4CC0 (0xED) – Timer 4 Channel 0 Compare Value .....	123
T4CC1 (0xEF) – Timer 4 Channel 1 Compare Value .....	124
T4CCTL0 (0xEC) – Timer 4 Channel 0 Compare Control .....	123
T4CCTL1 (0xEE) – Timer 4 Channel 1 Compare Control .....	124
T4CNT (0xEA) – Timer 4 Counter .....	121
T4CTL (0xEB) – Timer 4 Control .....	122
TCON (0x88) – Interrupt Flags .....	54
TIMIF (0xD8) – Timers 1/3/4 Interrupt Mask/Flag .....	125
TXCTRLH (0xDF0A) .....	189
TXCTRLL (0xDF0B) .....	190
U0BAUD (0xC2) – USART 0 Baud Rate Control .....	149
U0CSR (0x86) – USART 0 Control and Status .....	147
U0DBUF (0xC1) – USART 0 Receive/Transmit Data Buffer .....	149
U0GCR (0xC5) – USART 0 Generic Control .....	149
U0UCR (0xC4) – USART 0 UART Control .....	148
U1BAUD (0xFA) – USART 1 Baud Rate Control .....	152
U1CSR (0xF8) – USART 1 Control and Status .....	150
U1DBUF (0xF9) – USART 1 Receive/Transmit Data Buffer .....	152
U1GCR (0xFC) – USART 1 Generic Control .....	152
U1UCR (0xFB) – USART 1 UART Control .....	151
WDCTL (0xC9) – Watchdog Timer Control .....	142

### 18 Package Description (QLP 48)

All dimensions are in millimeters, angles in degrees. NOTE: The **CC2430** is available in RoHS lead-free package only. Compliant with JEDEC MS-020.

Table 51: Package dimensions

Quad Leadless Package (QLP)										
		D	D1	E	E1	e	b	L	D2	E2
QLP 48	Min	6.9	6.65	6.9	6.65	0.5	0.18	0.3	5.05	5.05
		7.0	6.75	7.0	6.75				5.10	5.10
	Max	7.1	6.85	7.1	6.85				0.30	0.5

The overall package height is 0.85 +/- 0.05  
All dimensions in mm

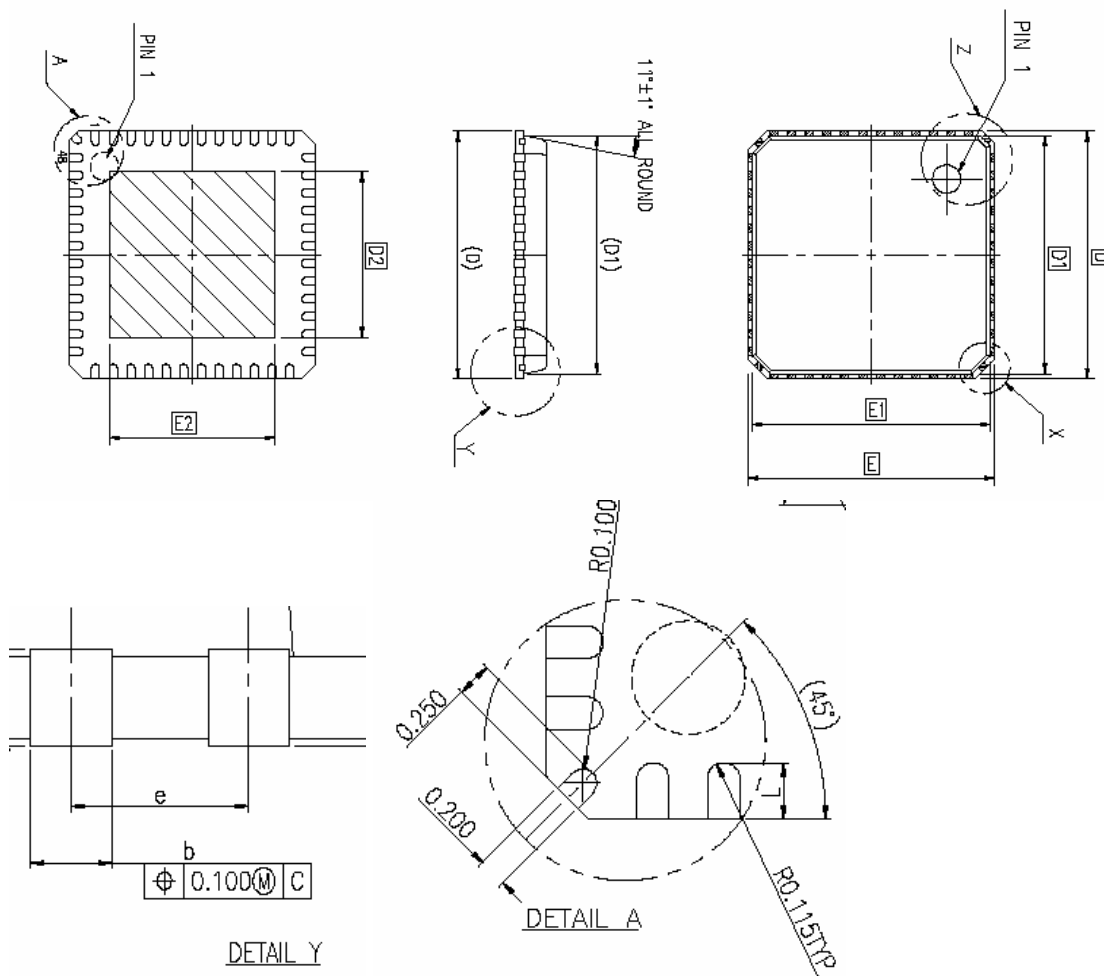

Figure 51: Package dimensions drawing

18.1 Recommended PCB layout for package (QLP 48)

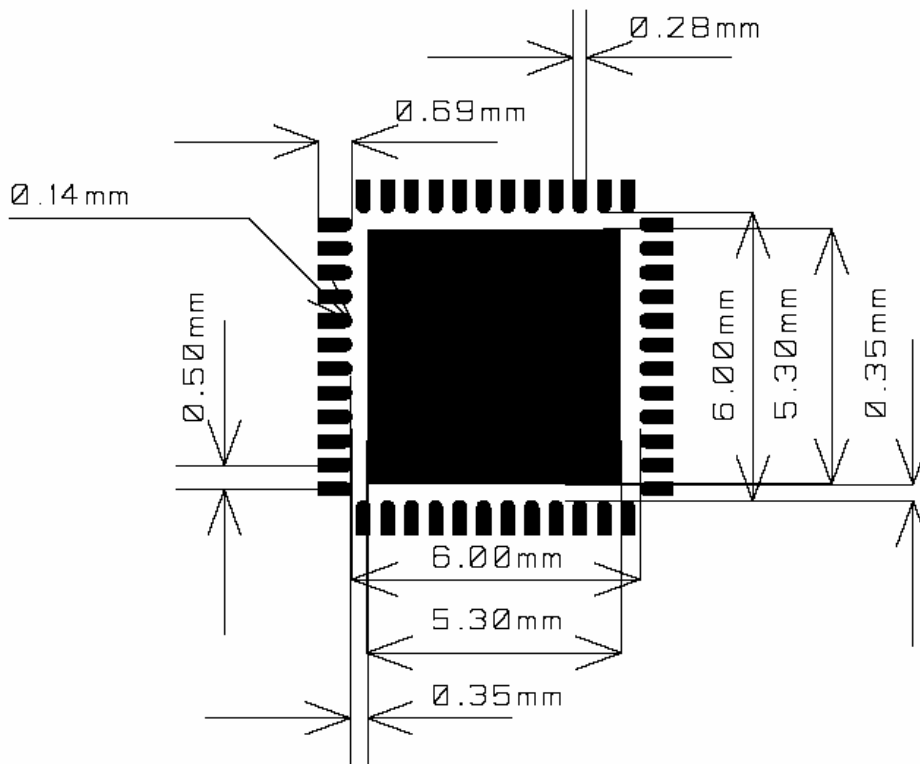

Figure 52: Recommended PCB layout for QLP 48 package

Note: The figure is an illustration only and not to scale. There are nine 14 mil diameter via holes distributed symmetrically in the ground pad under the package. See also the *CC2430* EM reference design

18.2 Package thermal properties

Table 52: Thermal properties of QLP 48 package

Thermal resistance	
Air velocity [m/s]	0
Rth,j-a [K/W]	25.6

18.3 Soldering information

The recommendations for lead-free solder reflow in IPC/JEDEC J-STD-020C should be followed.

18.4 Tray specification

Table 53: Tray specification

Tray Specification				
Package	Tray Width	Tray Height	Tray Length	Units per Tray
QLP 48	135.9mm ± 0.25mm	7.62mm ± 0.13mm	322.6mm ± 0.25mm	260

18.5 Carrier tape and reel specification

Carrier tape and reel is in accordance with EIA Specification 481.

**Table 54: Carrier tape and reel specification**

Tape and Reel Specification					
Package	Tape Width	Component Pitch	Hole Pitch	Reel Diameter	Units per Reel
QLP 48	16mm	12mm	4mm	13 inches	2500

## 19 Ordering Information

**Table 55: Ordering Information**

Ordering part number	Description	MOQ
CC2430F128RTC	CC2430, QLP48 package, RoHS compliant Pb-free assembly, trays with 260 pcs per tray, 128 Kbytes in-system programmable flash memory, System-on-chip RF transceiver.	260
CC2430F128RTCR	CC2430, QLP48 package, RoHS compliant Pb-free assembly, T&R with 2500 pcs per reel, 128 Kbytes in-system programmable flash memory, System-on-chip RF transceiver.	2,500
CC2430ZF128RTC	CC2430, QLP48 package, RoHS compliant Pb-free assembly, trays with 260 pcs per tray, 128 Kbytes in-system programmable flash memory, System-on-chip RF transceiver, including royalty for using TI's ZigBee® Software Stack, Z-Stack™, in an end product	260
CC2430ZF128RTCR	CC2430, QLP48 package, RoHS compliant Pb-free assembly, T&R with 2500 pcs per reel, 128 Kbytes in-system programmable flash memory, System-on-chip RF transceiver, including royalty for using TI's ZigBee® Software Stack, Z-Stack™, in an end product	2,500
CC2430F64RTC	CC2430, QLP48 package, RoHS compliant Pb-free assembly, trays with 260 pcs per tray, 64 Kbytes in-system programmable flash memory, System-on-chip RF transceiver.	260
CC2430F64RTCR	CC2430, QLP48 package, RoHS compliant Pb-free assembly, T&R with 2500 pcs per reel, 64 Kbytes in-system programmable flash memory, System-on-chip RF transceiver.	2,500
CC2430F32RTC	CC2430, QLP48 package, RoHS compliant Pb-free assembly, trays with 260 pcs per tray, 32 Kbytes in-system programmable flash memory, System-on-chip RF transceiver.	260
CC2430F32RTCR	CC2430, QLP48 package, RoHS compliant Pb-free assembly, T&R with 2500 pcs per reel, 32 Kbytes in-system programmable flash memory, System-on-chip RF transceiver.	2,500
CC2430DK	CC2430 DK Development kit.	1
CC2430ZDK	CC2430 ZigBee® DK Development kit	1
CC2430EMK	CC2430 Evaluation Module Kit	1
CC2430DB	CC2430 Demonstration Board	1

MOQ = Minimum Order Quantity      T&R = tape and reel

## 20 General Information

### 20.1 Document History

**Table 56: Document History**

Revision	Date	Description/Changes
2.1	2007-05-30	First data sheet for released product. Preliminary data sheets exist for engineering samples and pre-production prototype devices, but these data sheets are not complete and may be incorrect in some aspects compared with the released product.

## 21 Address Information

Texas Instruments Norway AS  
Gautstadalléen 21  
N-0349 Oslo  
NORWAY  
Tel: +47 22 95 85 44  
Fax: +47 22 95 85 46  
Web site: <http://www.ti.com/lpw>

## 22 TI Worldwide Technical Support

### Internet

TI Semiconductor Product Information Center Home Page: [support.ti.com](http://support.ti.com)  
TI Semiconductor KnowledgeBase Home Page: [support.ti.com/sc/knowledgebase](http://support.ti.com/sc/knowledgebase)

## Product Information Centers

### Americas

**Phone:** +1(972) 644-5580  
**Fax:** +1(972) 927-6377  
**Internet/Email:** [support.ti.com/sc/pic/americas.htm](http://support.ti.com/sc/pic/americas.htm)

### Europe, Middle East and Africa

**Phone:**  
Belgium (English) +32 (0) 27 45 54 32  
Finland (English) +358 (0) 9 25173948  
France +33 (0) 1 30 70 11 64  
Germany +49 (0) 8161 80 33 11  
Israel (English) 180 949 0107  
Italy 800 79 11 37  
Netherlands (English) +31 (0) 546 87 95 45  
Russia +7 (0) 95 363 4824  
Spain +34 902 35 40 28  
Sweden (English) +46 (0) 8587 555 22  
United Kingdom +44 (0) 1604 66 33 99  
**Fax:** +49 (0) 8161 80 2045  
**Internet:** [support.ti.com/sc/pic/euro.htm](http://support.ti.com/sc/pic/euro.htm)

## Japan

<b>Fax</b>	International	+81-3-3344-5317
	Domestic	0120-81-0036
<b>Internet/Email</b>	International	support.ti.com/sc/pic/japan.htm
	Domestic	www.tij.co.jp/pic

## Asia

<b>Phone</b>	International	+886-2-23786800
	Domestic	<u>Toll-Free Number</u>
	Australia	1-800-999-084
	China	800-820-8682
	Hong Kon	800-96-5941
	India	+91-80-51381665 (Toll)
	Indonesia	001-803-8861-1006
	Korea	080-551-2804
	Malaysia	1-800-80-3973
	New Zealand	0800-446-934
	Philippines	1-800-765-7404
	Singapore	800-886-1028
	Taiwan	0800-006800
Thailand	001-800-886-0010	
<b>Fax</b>		+886-2-2378-6808
<b>Email</b>		tiasia@ti.com or ti-china@ti.com
<b>Internet</b>		support.ti.com/sc/pic/asia.htm

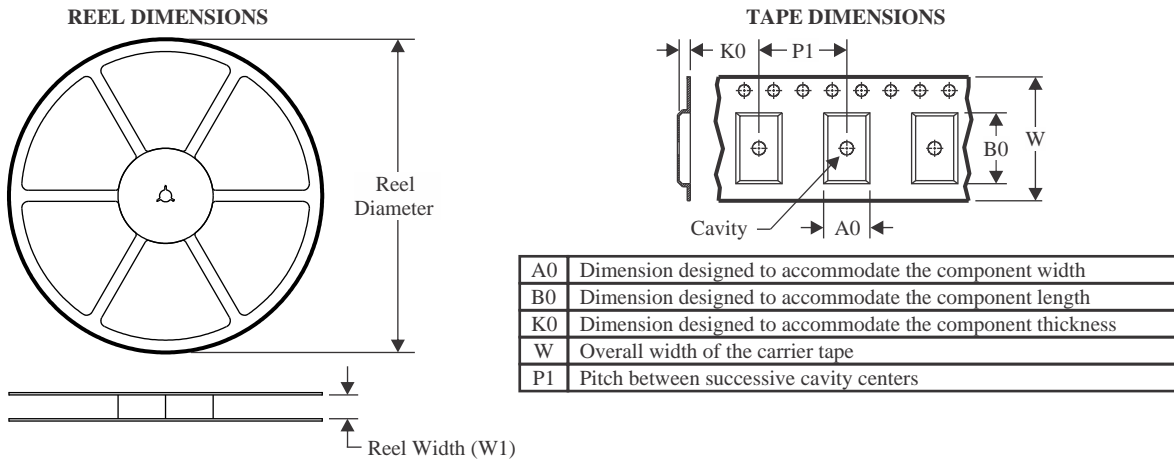
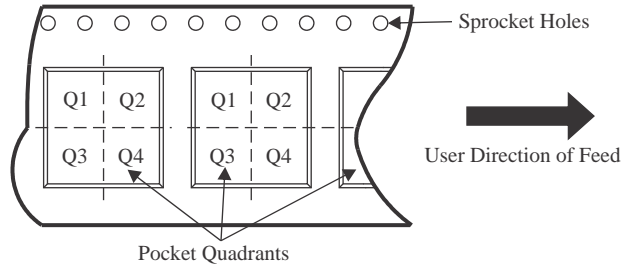
**TAPE AND REEL INFORMATION**

**QUADRANT ASSIGNMENTS FOR PIN 1 ORIENTATION IN TAPE**

\*All dimensions are nominal

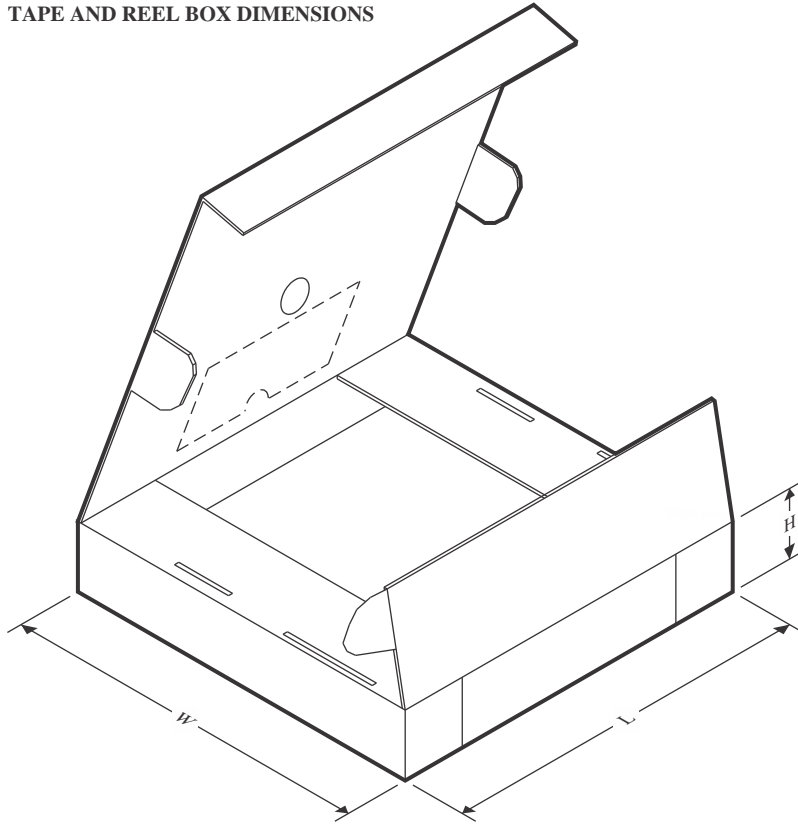
Device	Package Type	Package Drawing	Pins	SPQ	Reel Diameter (mm)	Reel Width W1 (mm)	A0 (mm)	B0 (mm)	K0 (mm)	P1 (mm)	W (mm)	Pin1 Quadrant
CC2430F32RTCR	VQFN	RTC	48	2500	330.0	16.4	7.3	7.3	1.5	12.0	16.0	Q2
CC2430F64RTCR	VQFN	RTC	48	2500	330.0	16.4	7.3	7.3	1.5	12.0	16.0	Q2
CC2430ZF128RTCR	VQFN	RTC	48	2500	330.0	16.4	7.3	7.3	1.5	12.0	16.0	Q2

**TAPE AND REEL BOX DIMENSIONS**

\*All dimensions are nominal

Device	Package Type	Package Drawing	Pins	SPQ	Length (mm)	Width (mm)	Height (mm)
CC2430F32RCTR	VQFN	RTC	48	2500	350.0	350.0	43.0
CC2430F64RCTR	VQFN	RTC	48	2500	350.0	350.0	43.0
CC2430ZF128RCTR	VQFN	RTC	48	2500	350.0	350.0	43.0

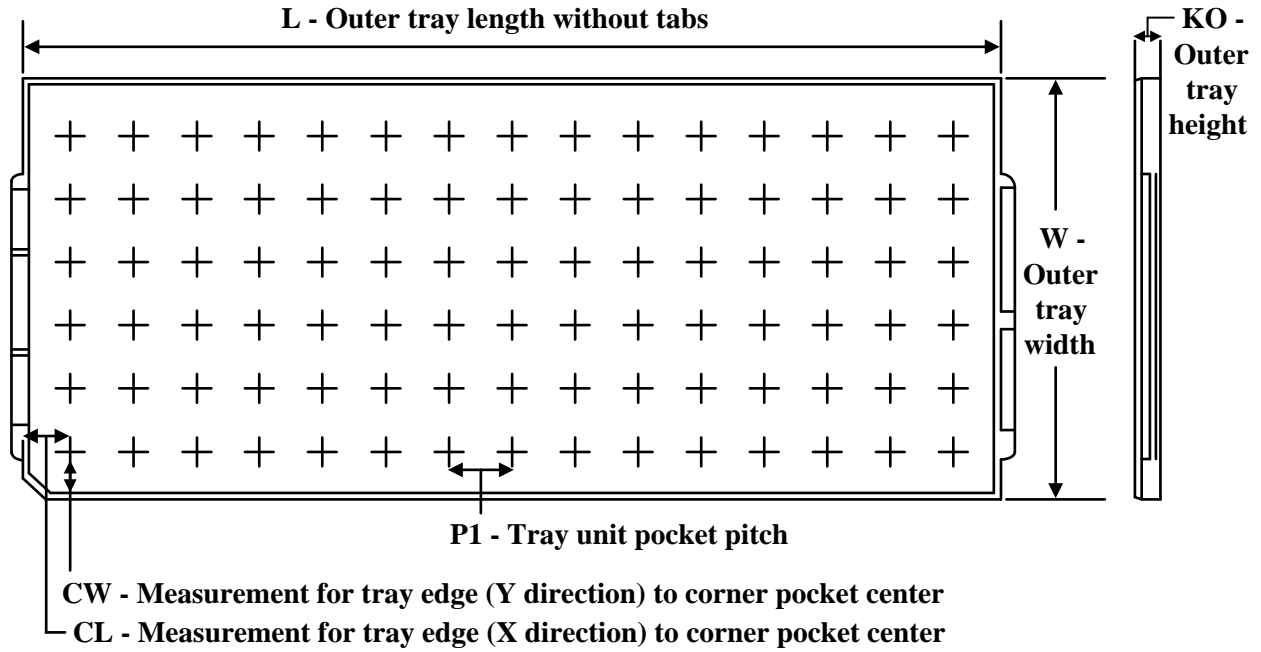
**TRAY**

Chamfer on Tray corner indicates Pin 1 orientation of packed units.

\*All dimensions are nominal

Device	Package Name	Package Type	Pins	SPQ	Unit array matrix	Max temperature (°C)	L (mm)	W (mm)	K0 (µm)	P1 (mm)	CL (mm)	CW (mm)
CC2430F128RTC	RTC	VQFNP	48	260	26 x 10	150	322.6	135.9	7620	11.8	10	10.35
CC2430F32RTC	RTC	VQFNP	48	260	26 x 10	150	322.6	135.9	7620	11.8	10	10.35
CC2430F64RTC	RTC	VQFNP	48	260	26 x 10	150	322.6	135.9	7620	11.8	10	10.35
CC2430ZF128RTC	RTC	VQFNP	48	260	26 x 10	150	322.6	135.9	7620	11.8	10	10.35

## IMPORTANT NOTICE AND DISCLAIMER

TI PROVIDES TECHNICAL AND RELIABILITY DATA (INCLUDING DATA SHEETS), DESIGN RESOURCES (INCLUDING REFERENCE DESIGNS), APPLICATION OR OTHER DESIGN ADVICE, WEB TOOLS, SAFETY INFORMATION, AND OTHER RESOURCES "AS IS" AND WITH ALL FAULTS, AND DISCLAIMS ALL WARRANTIES, EXPRESS AND IMPLIED, INCLUDING WITHOUT LIMITATION ANY IMPLIED WARRANTIES OF MERCHANTABILITY, FITNESS FOR A PARTICULAR PURPOSE OR NON-INFRINGEMENT OF THIRD PARTY INTELLECTUAL PROPERTY RIGHTS.

These resources are intended for skilled developers designing with TI products. You are solely responsible for (1) selecting the appropriate TI products for your application, (2) designing, validating and testing your application, and (3) ensuring your application meets applicable standards, and any other safety, security, regulatory or other requirements.

These resources are subject to change without notice. TI grants you permission to use these resources only for development of an application that uses the TI products described in the resource. Other reproduction and display of these resources is prohibited. No license is granted to any other TI intellectual property right or to any third party intellectual property right. TI disclaims responsibility for, and you will fully indemnify TI and its representatives against, any claims, damages, costs, losses, and liabilities arising out of your use of these resources.

TI's products are provided subject to [TI's Terms of Sale](#) or other applicable terms available either on [ti.com](https://www.ti.com) or provided in conjunction with such TI products. TI's provision of these resources does not expand or otherwise alter TI's applicable warranties or warranty disclaimers for TI products.

TI objects to and rejects any additional or different terms you may have proposed.

Mailing Address: Texas Instruments, Post Office Box 655303, Dallas, Texas 75265  
Copyright © 2023, Texas Instruments Incorporated



## Looking for pricing, stock, or lifecycle information?

Click below to explore more details on WIN SOURCE:

 [View CC2430ZF128RTCR on WIN SOURCE](#)

 [Texas Instruments](#) Information

## Optimize Your Supply Chain with WIN SOURCE Solutions

-  Global Sourcing Solution
-  Obsolete Management
-  Cost Control Management
-  Shortage Management
-  Alternative Solution
-  Excess Inventory Management