



**THE DATASHEET OF
IRS2336JPBF**



Features

- Drives up to six IGBT/MOSFET power devices
- Gate drive supplies up to 20 V per channel
- Integrated bootstrap functionality (IRS2336(4)D)
- Over-current protection
- Over-temperature shutdown input
- Advanced input filter
- Integrated deadtime protection
- Shoot-through (cross-conduction) protection
- Undervoltage lockout for V_{CC} & V_{BS}
- Enable/disable input and fault reporting
- Adjustable fault clear timing
- Separate logic and power grounds
- 3.3 V input logic compatible
- Tolerant to negative transient voltage
- Designed for use with bootstrap power supplies
- Matched propagation delays for all channels
- -40°C to 125°C operating range
- RoHS compliant
- Lead-Free

Typical Applications

- Appliance motor drives
- Servo drives
- Micro inverter drives
- General purpose three phase inverters

Product Summary

Topology		3 Phase
V_{OFFSET}		$\leq 600\text{ V}$
V_{OUT}	IRS2336(D)	10 V – 20 V
	IRS23364D	11.5 V – 20 V
$I_{\text{O+}} \& I_{\text{O-}}$ (typical)		200 mA & 350 mA
$t_{\text{ON}} \& t_{\text{OFF}}$ (typical)		530 ns & 530 ns
Deadtime (typical)		275 ns

Package Options

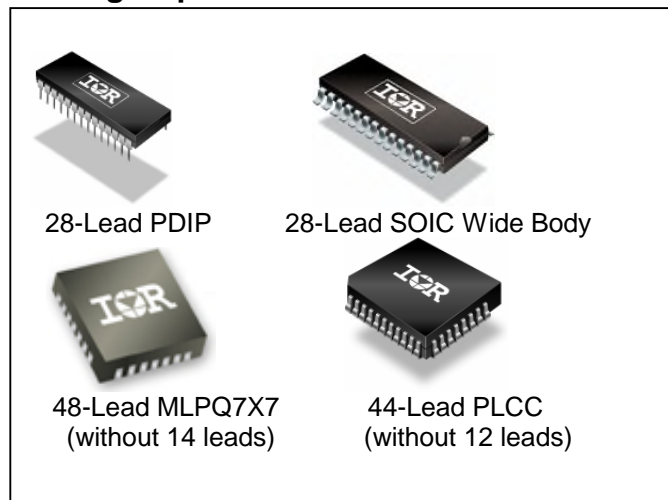

Typical Connection Diagram

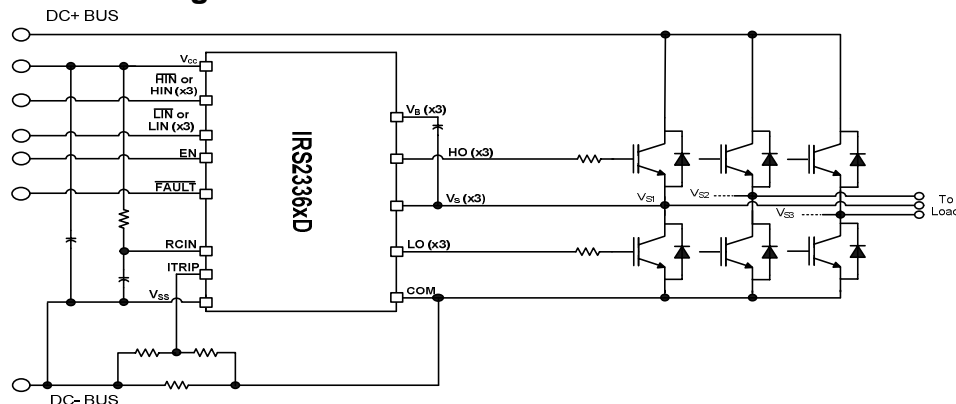

Table of Contents	Page
Description	3
Feature Comparison	3
Simplified Block Diagram	4
Typical Application Diagram	4
Qualification Information	5
Absolute Maximum Ratings	6
Recommended Operating Conditions	7
Static Electrical Characteristics	8-9
Dynamic Electrical Characteristics	10
Functional Block Diagram	11-12
Input/Output Pin Equivalent Circuit Diagram	13-14
Lead Definitions	15-16
Lead Assignments	17
Application Information and Additional Details	18-35
Parameter Temperature Trends	36-39
Package Details	40-43
Tape and Reel Details	44-46
Part Marking Information	47
Ordering Information	48

Description

The IRS2336xD are high voltage, high speed, power MOSFET and IGBT gate drivers with three high-side and three low-side referenced output channels for 3-phase applications. This IC is designed to be used with low-cost bootstrap power supplies; the bootstrap diode functionality has been integrated into this device to reduce the component count and the PCB size. Proprietary HVIC and latch immune CMOS technologies have been implemented in a rugged monolithic structure. The floating logic input is compatible with standard CMOS or LSTTL outputs (down to 3.3 V logic). A current trip function which terminates all six outputs can be derived from an external current sense resistor. Enable functionality is available to terminate all six outputs simultaneously. An open-drain FAULT signal is provided to indicate that a fault (e.g., over-current, over-temperature, or undervoltage shutdown event) has occurred. Fault conditions are cleared automatically after a delay programmed externally via an RC network connected to the RCIN input. The output drivers feature a high-pulse current buffer stage designed for minimum driver cross-conduction. Shoot-through protection circuitry and a minimum deadtime circuitry have been integrated into this IC. Propagation delays are matched to simplify the HVIC's use in high frequency applications. The floating channels can be used to drive N-channel power MOSFETs or IGBTs in the high-side configuration, which operate up to 600 V.

Feature Comparison: IRS2336xD Family

Part Number	Input Logic	UVLO	$V_{IT,TH}$	t_{ON}, t_{OFF}	V_{OUT}
IRS2336(D)	HIN/N, LIN/N	8.9 V/ 8.2 V	0.46 V	530 ns, 530 ns	10 V – 20 V
IRS23364D	HIN, LIN	11.1 V/ 10.9 V	0.46 V	530 ns, 530 ns	11.5 V – 20 V

Simplified Block Diagram

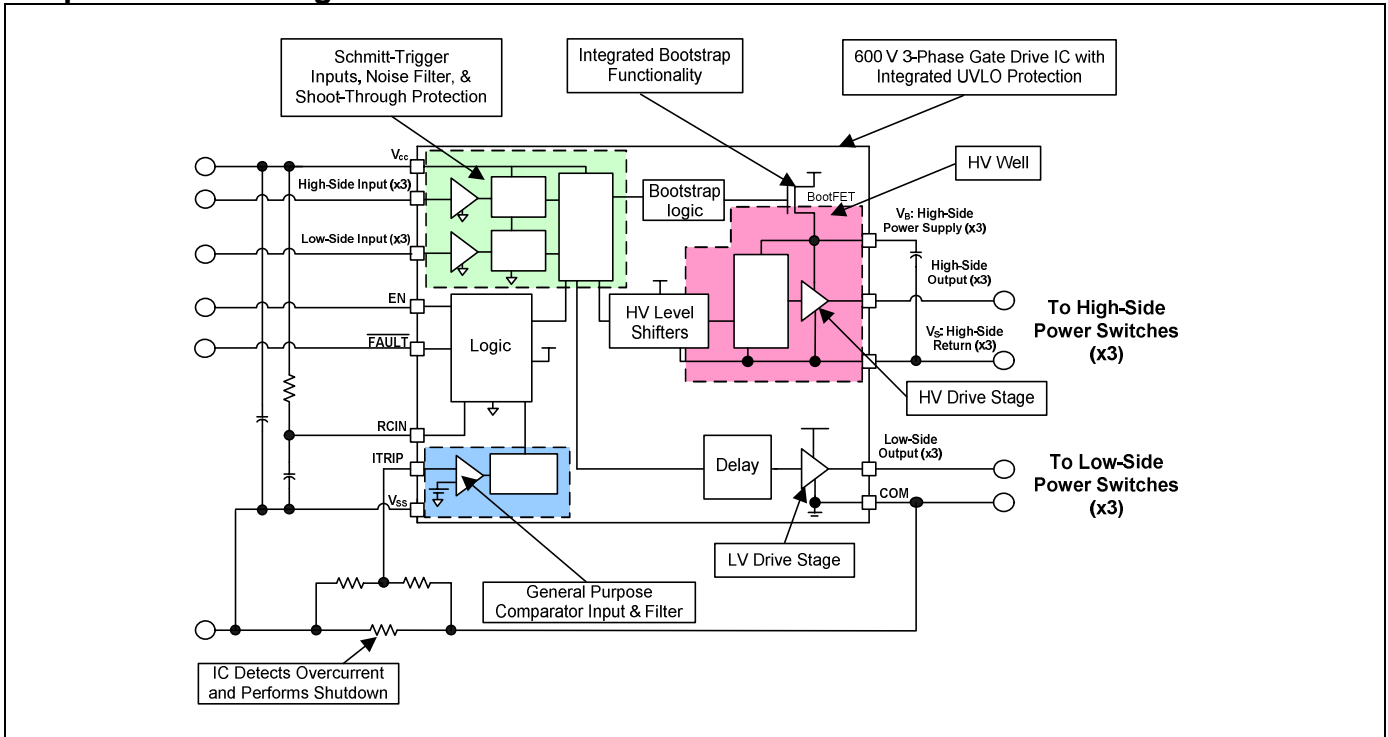

Typical Application Diagram

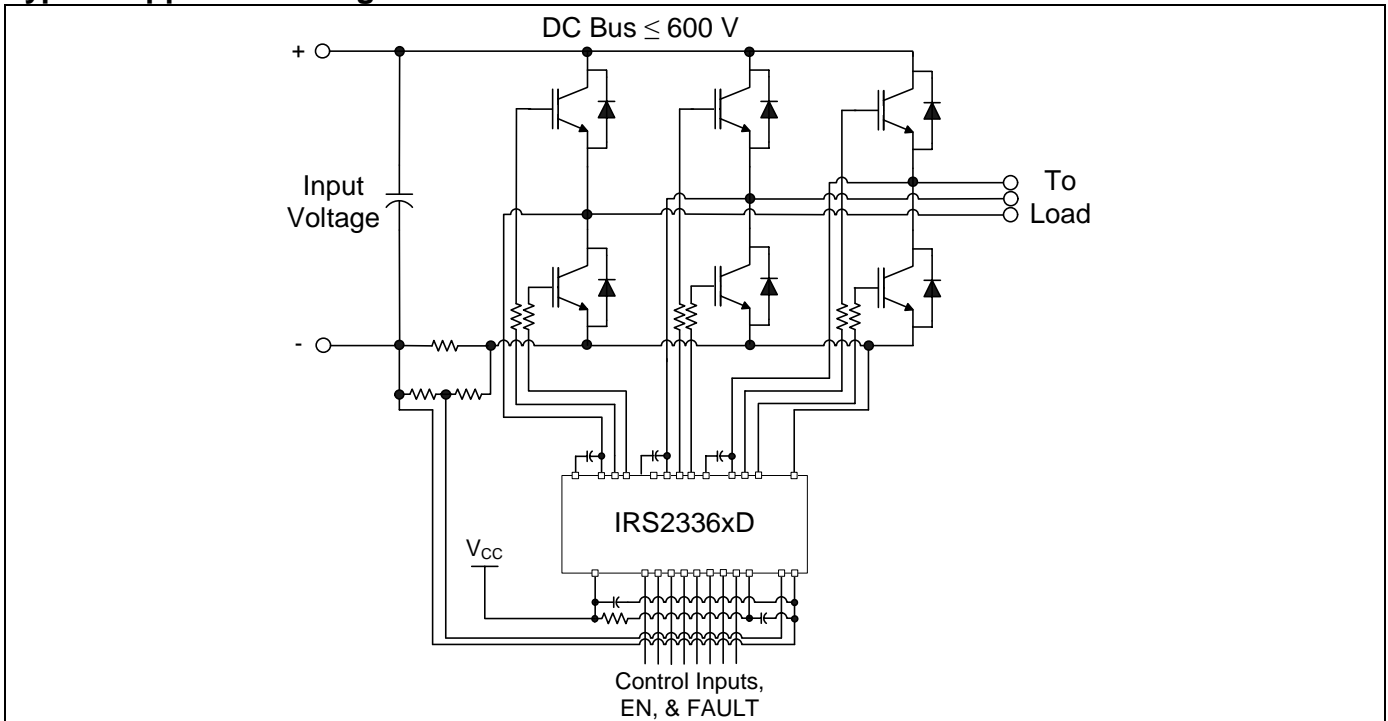

Qualification Information†

Qualification Level		Industrial††	
		Comments: This family of ICs has passed JEDEC's Industrial qualification. IR's Consumer qualification level is granted by extension of the higher Industrial level.	
Moisture Sensitivity Level		SOIC28W	MSL3†††, 260°C (per IPC/JEDEC J-STD-020)
		MLPQ7X7	
		PLCC44	MSL3†††, 245°C (per IPC/JEDEC J-STD-020)
		PDIP28	Not applicable (non-surface mount package style)
ESD	Human Body Model	Class 1C (per JEDEC standard JESD22-A114)	
	Machine Model	Class B (per EIA/JEDEC standard EIA/JESD22-A115)	
	Charged Device Model †††	Class IV (per JEDEC standard JESD22-C101)	
IC Latch-Up Test		Class I, Level A (per JESD78)	
RoHS Compliant		Yes	

† Qualification standards can be found at International Rectifier's web site <http://www.irf.com/>

†† Higher qualification ratings may be available should the user have such requirements. Please contact your International Rectifier sales representative for further information.

††† Higher MSL ratings may be available for the specific package types listed here. Please contact your International Rectifier sales representative for further information.

†††† Charged Device Model classification is based on SOIC28W package.

Absolute Maximum Ratings

Absolute maximum ratings indicate sustained limits beyond which damage to the device may occur. All voltage parameters are absolute voltages referenced to V_{SS} unless otherwise stated in the table. The thermal resistance and power dissipation ratings are measured under board mounted and still air conditions. Voltage clamps are included between V_{CC} & COM (25 V), V_{CC} & V_{SS} (20 V), and V_B & V_S (20 V).

Symbol	Definition		Min	Max	Units
V_{CC}	Low side supply voltage		-0.3	20 [†]	V
V_{IN}	Logic input voltage (HIN, LIN, ITRIP, EN)	IRS2336(D)	$V_{SS}-0.3$	$V_{SS}+5.2$	
		IRS23364D	$V_{SS}-0.3$	$V_{CC}+0.3$	
V_{RCIN}	RCIN input voltage		$V_{SS}-0.3$	$V_{CC}+0.3$	
V_B	High-side floating well supply voltage		-0.3	620 [†]	
V_S	High-side floating well supply return voltage		V_B-20^{\dagger}	$V_B+0.3$	
V_{HO}	Floating gate drive output voltage		$V_S-0.3$	$V_B+0.3$	
V_{LO}	Low-side output voltage		COM-0.3	$V_{CC}+0.3$	
V_{FLT}	Fault output voltage		$V_{SS}-0.3$	$V_{CC}+0.3$	
COM	Power ground		$V_{CC}-25$	$V_{CC}+0.3$	
dV_S/dt	Allowable V_S offset supply transient relative to V_{SS}		—	50	
PW_{HIN}	High-side input pulse width		500	—	ns
P_D	Package power dissipation @ $T_A \leq +25^{\circ}\text{C}$	28-Lead PDIP	—	1.5	W
		28-Lead SOICW	—	1.6	
		44-Lead PLCC	—	2.0	
		48-Lead MLPQ7X7	—	2.0	
R_{thJA}	Thermal resistance, junction to ambient	28-Lead PDIP	—	83	$^{\circ}\text{C}/\text{W}$
		28-Lead SOICW	—	78	
		44-Lead PLCC	—	63	
		48-Lead MLPQ7X7	—	63	
T_J	Junction temperature		—	150	$^{\circ}\text{C}$
T_S	Storage temperature		-55	150	
T_L	Lead temperature (soldering, 10 seconds)		—	300	

† All supplies are tested at 25 V. An internal 20 V clamp exists for each supply.

Recommended Operating Conditions

For proper operation, the device should be used within the recommended conditions. All voltage parameters are absolute voltages referenced to V_{SS} unless otherwise stated in the table. The offset rating is tested with supplies of $(V_{CC}-COM) = (V_B-V_S) = 15\text{ V}$.

Symbol	Definition	Min	Max	Units	
V_{CC}	Low-side supply voltage	IRS2336(D)	10	20	V
		IRS23364D	11.5	20	
V_{IN}	HIN, LIN, & EN input voltage	IRS2336(D)	V_{SS}	$V_{SS}+5$	
		IRS23364D		V_{CC}	
V_B	High-side floating well supply voltage	IRS2336(D)	V_S+10	V_S+20	
		IRS23364D	$V_S+11.5$	V_S+20	
V_S	High-side floating well supply offset voltage [†]	COM-8	600		
$V_S(t)$	Transient high-side floating supply voltage ^{††}	-50	600		
V_{HO}	Floating gate drive output voltage	V_S	V_B		
V_{LO}	Low-side output voltage	COM	V_{CC}		
COM	Power ground	-5	5		
V_{FLT}	FAULT output voltage	V_{SS}	V_{CC}		
V_{RCIN}	RCIN input voltage	V_{SS}	V_{CC}		
V_{ITRIP}	ITRIP input voltage	V_{SS}	$V_{SS}+5$		
T_A	Ambient temperature	-40	125	°C	

† Logic operation for V_S of -8 V to 600 V. Logic state held for V_S of -8 V to $-V_{BS}$. Please refer to Design Tip DT97-3 for more details.

†† Operational for transient negative V_S of $V_{SS} - 50\text{ V}$ with a 50 ns pulse width. Guaranteed by design. Refer to the Application Information section of this datasheet for more details.

Static Electrical Characteristics

(V_{CC-COM}) = (V_B-V_S) = 15 V. $T_A = 25^\circ\text{C}$ unless otherwise specified. The V_{IN} and I_{IN} parameters are referenced to V_{SS} and are applicable to all six channels. The V_O and I_O parameters are referenced to respective V_S and COM and are applicable to the respective output leads HO or LO. The V_{CCUV} parameters are referenced to V_{SS} . The V_{BSUV} parameters are referenced to V_S .

Symbol	Definition		Min	Typ	Max	Units	Test Conditions		
V_{CCUV+}	V_{CC} supply undervoltage positive going threshold	IRS2336(D)	8	8.9	9.8	V	NA		
		IRS23364D	10.4	11.1	11.6				
V_{CCUV-}	V_{CC} supply undervoltage negative going threshold	IRS2336(D)	7.4	8.2	9				
		IRS23364D	10.2	10.9	11.4				
V_{CCUVHY}	V_{CC} supply undervoltage hysteresis	IRS2336(D)	0.3	0.7	—				
		IRS23364D	—	0.2	—				
V_{BSUV+}	V_{BS} supply undervoltage positive going threshold	IRS2336(D)	8	8.9	9.8				
		IRS23364D	10.4	11.1	11.6				
V_{BSUV-}	V_{BS} supply undervoltage negative going threshold	IRS2336(D)	7.4	8.2	9				
		IRS23364D	10.2	10.9	11.4				
V_{BSUVHY}	V_{BS} supply undervoltage hysteresis	IRS2336(D)	0.3	0.7	—				
		IRS23364D	—	0.2	—				
I_{LK}	High-side floating well offset supply leakage		—	—	50	μA	$V_B = V_S = 600\text{ V}$		
I_{QBS}	Quiescent V_{BS} supply current		—	70	120		All inputs are in the off state		
I_{QCC}	Quiescent V_{CC} supply current	IRS2336	—	2	3	mA			
		IRS2336(4)D	—	3	4				
V_{OH}	High level output voltage drop, $V_{BIAS}-V_O$		—	0.90	1.4	V	$I_O = 20\text{ mA}$		
V_{OL}	Low level output voltage drop, V_O		—	0.40	0.6	V			
I_{O+}	Output high short circuit pulsed current		120	200	—	mA	$V_O=0\text{ V}, V_{IN}=0\text{ V},$ $PW \leq 10\ \mu\text{s}$		
I_{O-}	Output low short circuit pulsed current		250	350	—		$V_O=15\text{ V}, V_{IN}=5\text{ V},$ $PW \leq 10\ \mu\text{s}$		
V_{IH}	Logic "0" input voltage		2.5	—	—	V	NA		
	Logic "1" input voltage								
V_{IL}	Logic "1" input voltage		—	—	0.8				
	Logic "0" input voltage								
$V_{IN,CLAMP}$	Input voltage clamp (HIN, LIN, ITRIP and EN)	IRS2336(D)	4.8	5.2	5.65				$I_{IN} = 100\ \mu\text{A}$
I_{HIN+}	Input bias current (HO = High)	IRS2336(D)	—	150	200			μA	$V_{IN} = 0\text{ V}$
		IRS23364D	—	120	165	$V_{IN} = 4\text{ V}$			
I_{HIN-}	Input bias current (HO = Low)	IRS2336(D)	—	110	150	$V_{IN} = 0\text{ V}$			
		IRS23364D	—	—	1	$V_{IN} = 4\text{ V}$			
I_{LIN+}	Input bias current (LO = High)	IRS2336(D)	—	150	200	$V_{IN} = 0\text{ V}$			
		IRS23364D	—	120	165	$V_{IN} = 4\text{ V}$			
I_{LIN-}	Input bias current (LO = Low)	IRS2336(D)	—	110	150	$V_{IN} = 0\text{ V}$			
		IRS23364D	—	—	1				
$V_{RCIN,TH}$	RCIN positive going threshold		—	8	—	V	NA		
$V_{RCIN,HY}$	RCIN hysteresis		—	3	—				
I_{RCIN}	RCIN input bias current		—	—	1	μA	$V_{RCIN} = 0\text{ V or }15\text{ V}$		
$R_{ON,RCIN}$	RCIN low on resistance		—	50	100	Ω	$I = 1.5\text{ mA}$		

Static Electrical Characteristics (continued)

Symbol	Definition	Min	Typ	Max	Units	Test Conditions	
V _{IT,TH+}	ITRIP positive going threshold	0.37	0.46	0.55	V	NA	
V _{IT,TH-}	ITRIP negative going threshold	—	0.4	—			
V _{IT,HYS}	ITRIP hysteresis	—	0.07	—			
I _{ITRIP+}	“High” ITRIP input bias current	IRS2336(D)	—	5	20	μA	V _{IN} = 4 V
		IRS23364D	—	5	40		V _{IN} = 0 V
I _{ITRIP-}	“Low” ITRIP input bias current	—	—	1			
V _{EN,TH+}	Enable positive going threshold	—	—	2.5	V	NA	
V _{EN,TH-}	Enable negative going threshold	0.8	—	—			
I _{EN+}	“High” enable input bias current	IRS2336(D)	—	5	20	μA	V _{IN} = 4 V
		IRS23364D	—	120	165		
I _{EN-}	“Low” enable input bias current	—	—	1		V _{IN} = 0 V	
R _{ON,FLT}	FAULT low on resistance	—	50	100	Ω	I = 1.5 mA	
R _{BS}	Internal BS diode Ron (IRS2336(4)D)	—	200	—			NA

Dynamic Electrical Characteristics

$V_{CC} = V_B = 15\text{ V}$, $V_S = V_{SS} = \text{COM}$, $T_A = 25^\circ\text{C}$, and $C_L = 1000\text{ pF}$ unless otherwise specified.

Symbol	Definition	Min	Typ	Max	Units	Test Conditions
t_{ON}	Turn-on propagation delay	400	530	750	ns	$V_{IN} = 0\text{ V} \ \& \ 5\text{ V}$
t_{OFF}	Turn-off propagation delay	400	530	750		
t_R	Turn-on rise time	—	125	190		
t_F	Turn-off fall time	—	50	75		
$t_{FIL,IN}$	Input filter time [†] (H_{IN} , L_{IN} , I_{TRIP})	200	350	510		
t_{EN}	Enable low to output shutdown propagation delay	350	460	650	NA	$V_{IN}, V_{EN} = 0\text{ V} \ \text{or} \ 5\text{ V}$
$t_{FILTER,EN}$	Enable input filter time	100	200	—		NA
t_{FLTCLR}	FAULT clear time RCIN: $R = 2\text{ M}\Omega$, $C = 1\text{ nF}$	1.3	1.65	2		ms
t_{ITRIP}	ITRIP to output shutdown propagation delay	500	750	1200	ns	$V_{ITRIP} = 5\text{ V}$
t_{BL}	ITRIP blanking time	—	400	—		$V_{IN} = 0\text{ V} \ \text{or} \ 5\text{ V}$ $V_{ITRIP} = 5\text{ V}$
t_{FLT}	ITRIP to FAULT propagation delay	400	600	950		$V_{IN} = 0\text{ V} \ \& \ 5\text{ V}$ without external deadtime
DT	Deadtime	190	275	420		$V_{IN} = 0\text{ V} \ \& \ 5\text{ V}$ with external deadtime larger than DT
MDT	DT matching ^{††}	—	—	60		
MT	Delay matching time (t_{ON} , t_{OFF}) ^{††}	—	—	50		
PM	Pulse width distortion ^{†††}	—	—	75		

† The minimum width of the input pulse is recommended to exceed 500 ns to ensure the filtering time of the input filter is exceeded.

†† This parameter applies to all of the channels. Please see the application section for more details.

††† PM is defined as $PW_{IN} - PW_{OUT}$.

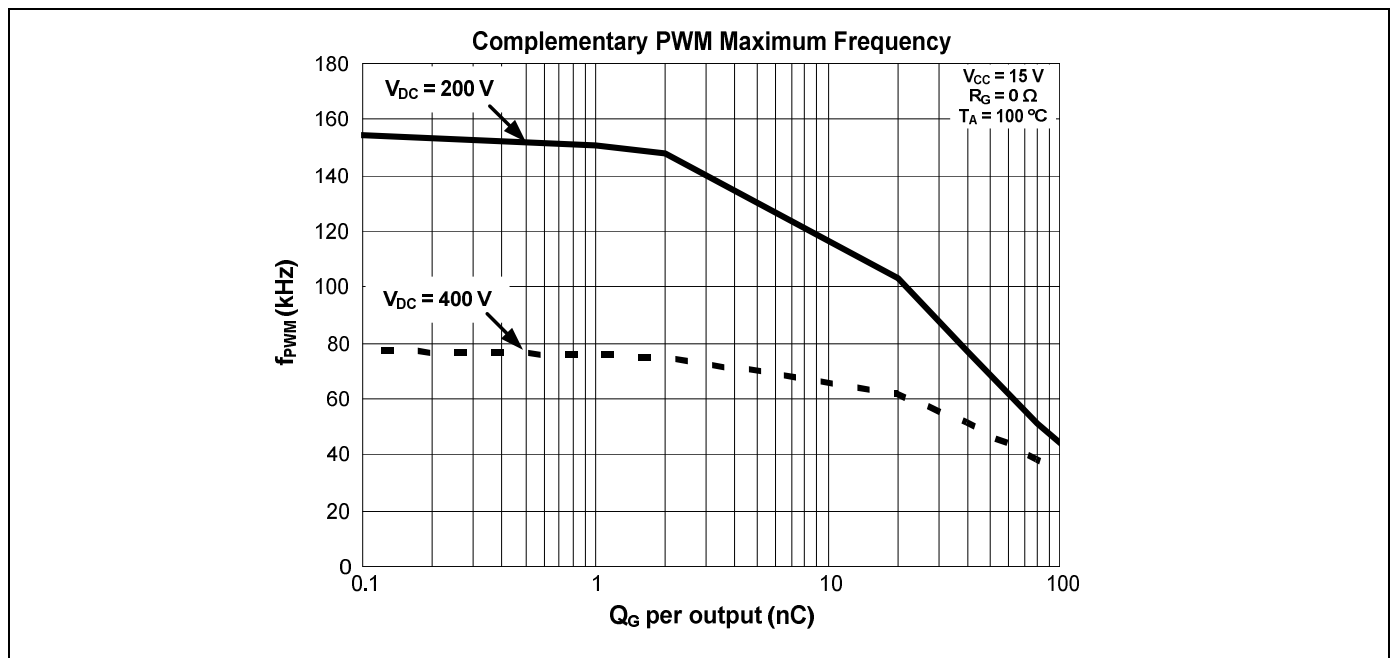

Functional Block Diagram: IRS2336(D)

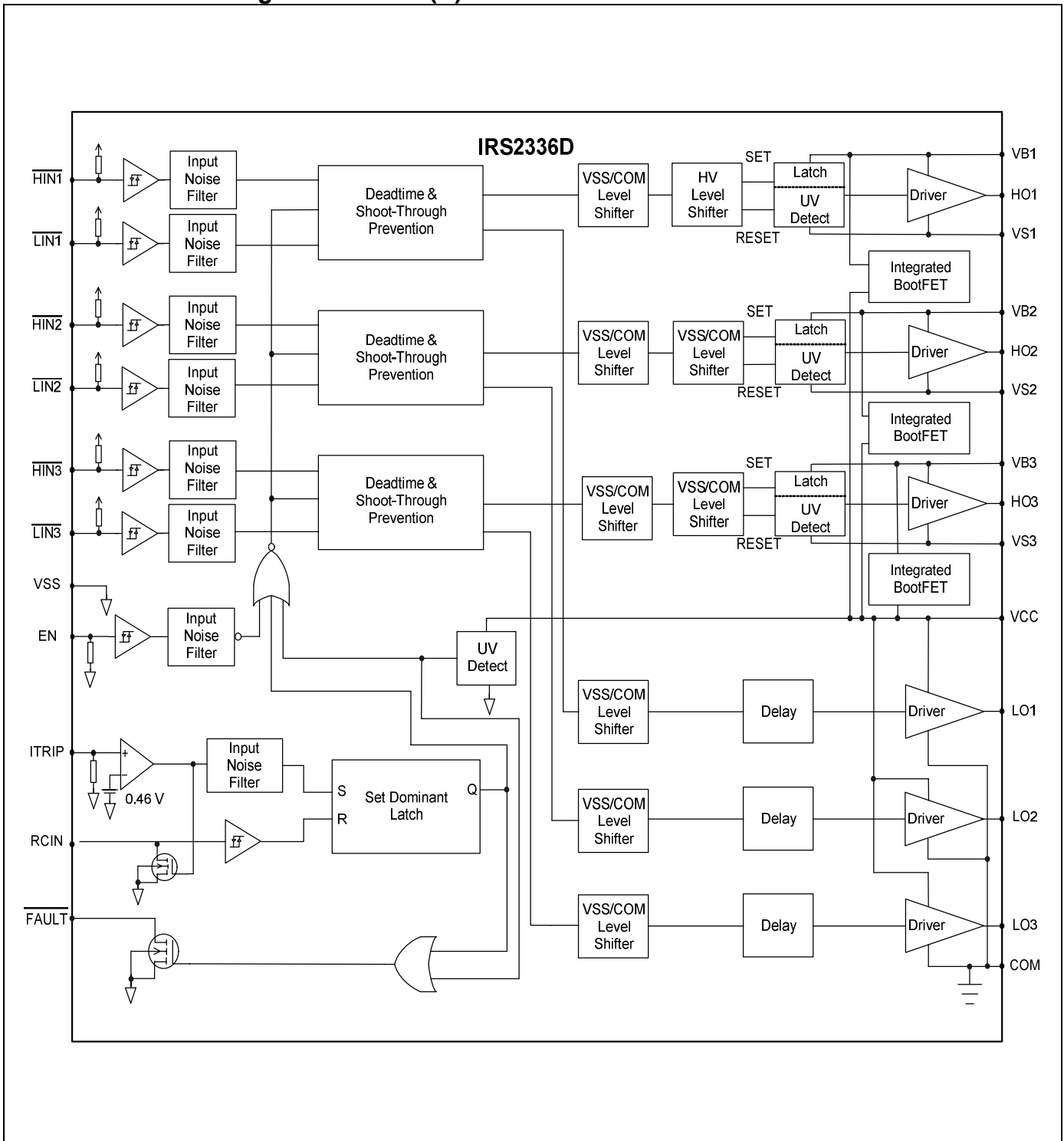

Note: IRS2336 is without the “Integrated BootFET”

Functional Block Diagram: IRS23364D

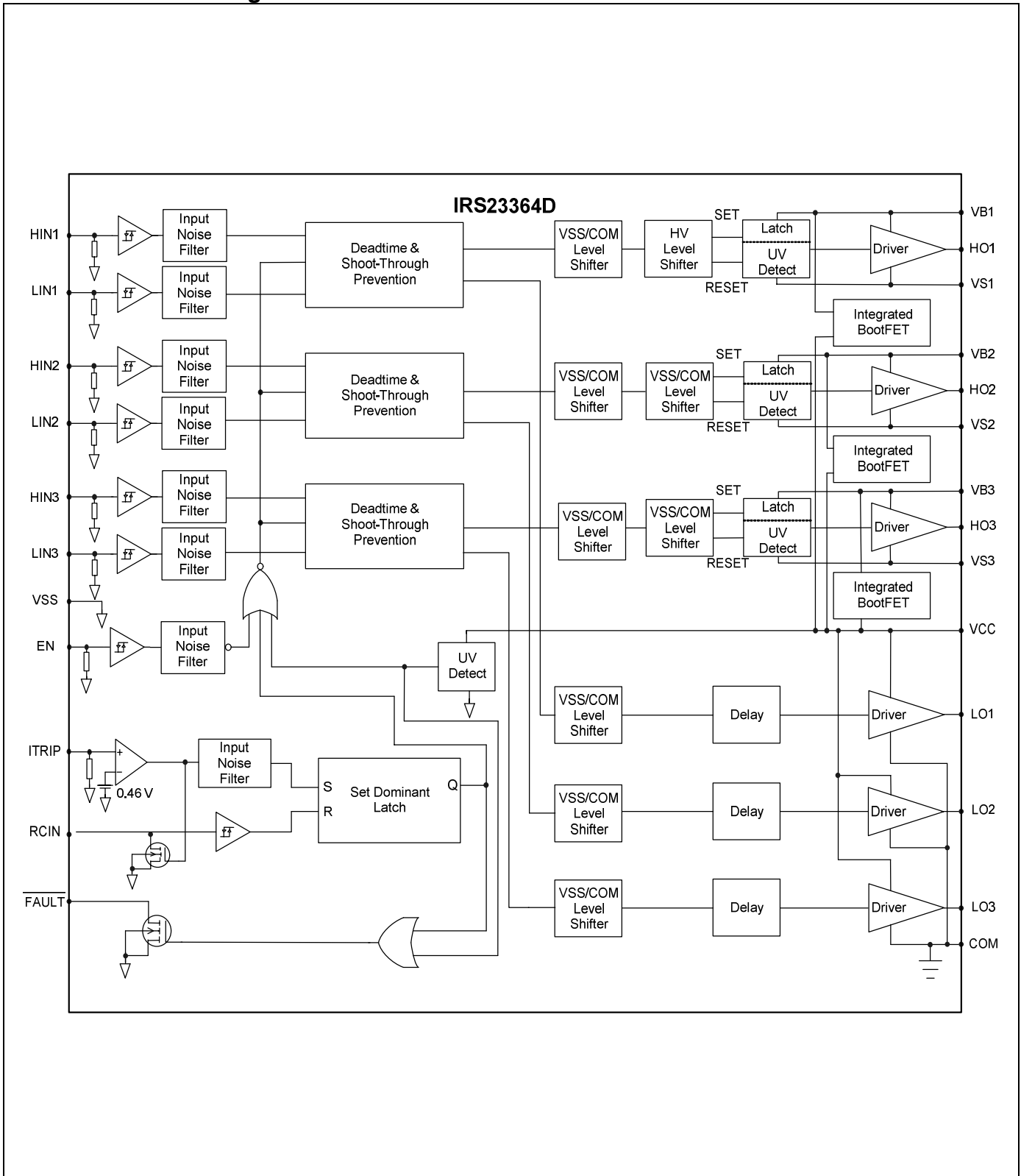

Input/Output Pin Equivalent Circuit Diagrams: IRS2336(D)

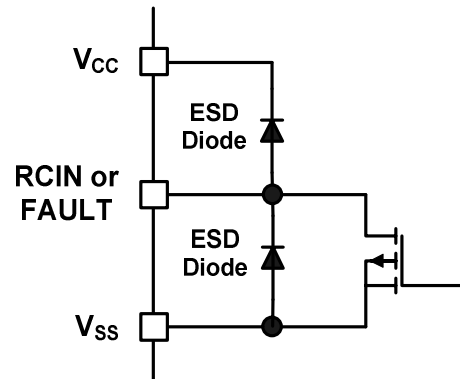
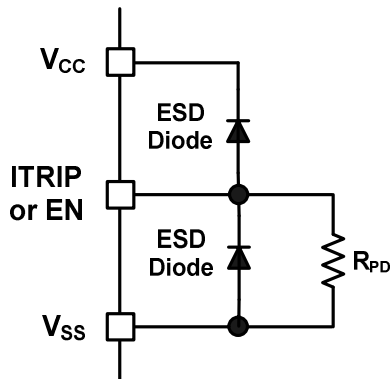
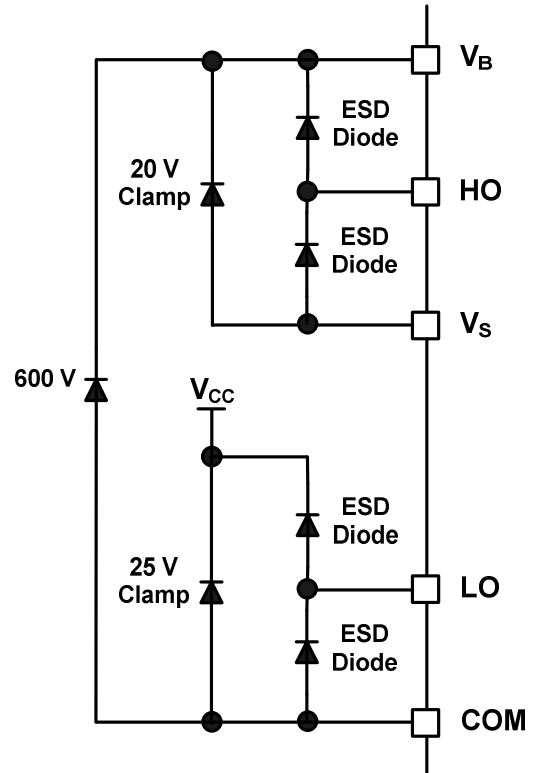
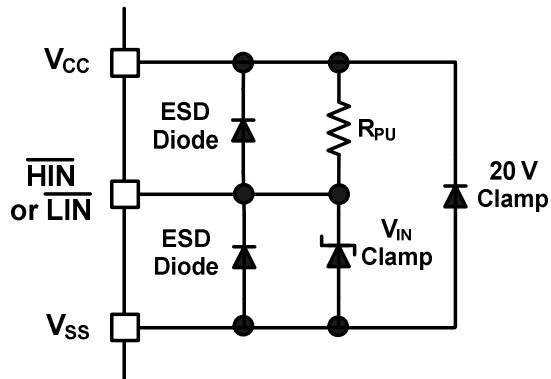

Input/Output Pin Equivalent Circuit Diagrams: IRS23364D

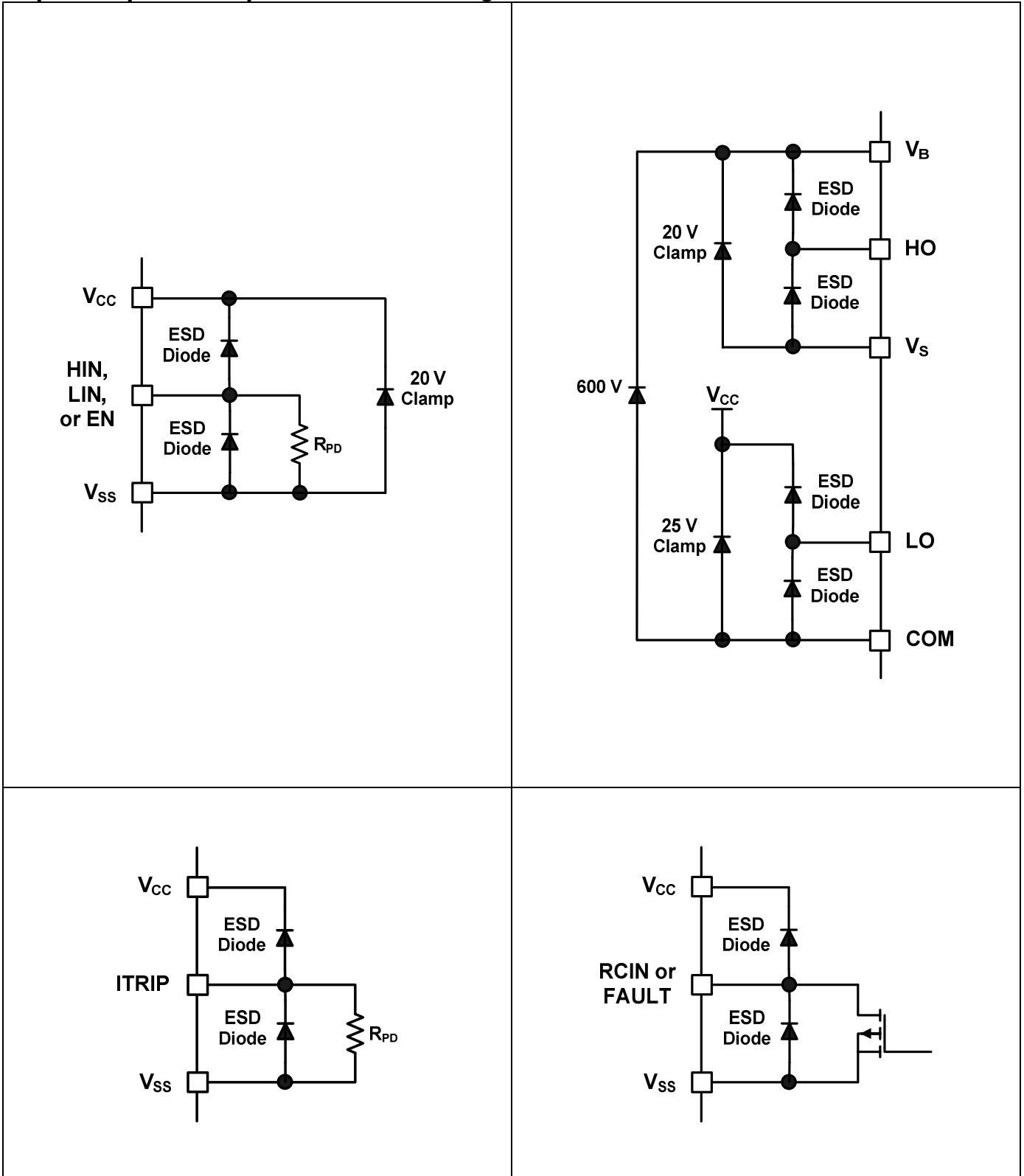

Lead Definitions: IRS2336(D)

Symbol	Description
VCC	Low-side supply voltage
VSS	Logic ground
VB1	High-side gate drive floating supply (phase 1)
VB2	High-side gate drive floating supply (phase 2)
VB3	High-side gate drive floating supply (phase 3)
VS1	High voltage floating supply return (phase 1)
VS2	High voltage floating supply return (phase 2)
VS3	High voltage floating supply return (phase 3)
HIN1/N	Logic inputs for high-side gate driver outputs (phase 1); input is out of phase with output
HIN2/N	Logic inputs for high-side gate driver outputs (phase 2); input is out of phase with output
HIN3/N	Logic inputs for high-side gate driver outputs (phase 3); input is out of phase with output
LIN1/N	Logic inputs for low-side gate driver outputs (phase 1); input is out of phase with output
LIN2/N	Logic inputs for low-side gate driver outputs (phase 2); input is out of phase with output
LIN3/N	Logic inputs for low-side gate driver outputs (phase 3); input is out of phase with output
HO1	High-side driver outputs (phase 1)
HO2	High-side driver outputs (phase 2)
HO3	High-side driver outputs (phase 3)
LO1	Low-side driver outputs (phase 1)
LO2	Low-side driver outputs (phase 2)
LO3	Low-side driver outputs (phase 3)
COM	Low-side gate drive return
FAULT/N	Indicates over-current, over-temperature (ITRIP), or low-side undervoltage lockout has occurred. This pin has negative logic and an open-drain output. The use of over-current and over-temperature protection requires the use of external components.
EN	Logic input to shutdown functionality. Logic functions when EN is high (i.e., positive logic). No effect on FAULT and not latched.
ITRIP	Analog input for over-current shutdown. When active, ITRIP shuts down outputs and activates FAULT and RCIN low. When ITRIP becomes inactive, FAULT stays active low for an externally set time t_{FLTCLR} , then automatically becomes inactive (open-drain high impedance).
RCIN	An external RC network input used to define the FAULT CLEAR delay (t_{FLTCLR}) approximately equal to $R \cdot C$. When $RCIN > 8\text{ V}$, the FAULT pin goes back into an open-drain high-impedance state.

Lead Definitions: IRS23364D

Symbol	Description
VCC	Low-side supply voltage
VSS	Logic ground
VB1	High-side gate drive floating supply (phase 1)
VB2	High-side gate drive floating supply (phase 2)
VB3	High-side gate drive floating supply (phase 3)
VS1	High voltage floating supply return (phase 1)
VS2	High voltage floating supply return (phase 2)
VS3	High voltage floating supply return (phase 3)
HIN1	Logic inputs for high-side gate driver outputs (phase 1); input is in-phase with output
HIN2	Logic inputs for high-side gate driver outputs (phase 2); input is in-phase with output
HIN3	Logic inputs for high-side gate driver outputs (phase 3); input is in-phase with output
LIN1	Logic inputs for low-side gate driver outputs (phase 1); input is in-phase with output
LIN2	Logic inputs for low-side gate driver outputs (phase 2); input is in-phase with output
LIN3	Logic inputs for low-side gate driver outputs (phase 3); input is in-phase with output
HO1	High-side driver outputs (phase 1)
HO2	High-side driver outputs (phase 2)
HO3	High-side driver outputs (phase 3)
LO1	Low-side driver outputs (phase 1)
LO2	Low-side driver outputs (phase 2)
LO3	Low-side driver outputs (phase 3)
COM	Low-side gate drive return
FAULT/N	Indicates over-current, over-temperature (ITRIP), or low-side undervoltage lockout has occurred. This pin has negative logic and an open-drain output. The use of over-current and over-temperature protection requires the use of external components.
EN	Logic input to shutdown functionality. Logic functions when EN is high (i.e., positive logic). No effect on FAULT and not latched.
ITRIP	Analog input for over-current shutdown. When active, ITRIP shuts down outputs and activates FAULT and RCIN low. When ITRIP becomes inactive, FAULT stays active low for an externally set time t_{FLTCLR} , then automatically becomes inactive (open-drain high impedance).
RCIN	An external RC network input used to define the FAULT CLEAR delay (t_{FLTCLR}) approximately equal to $R \cdot C$. When $RCIN > 8\text{ V}$, the FAULT pin goes back into an open-drain high-impedance state.

Lead Assignments

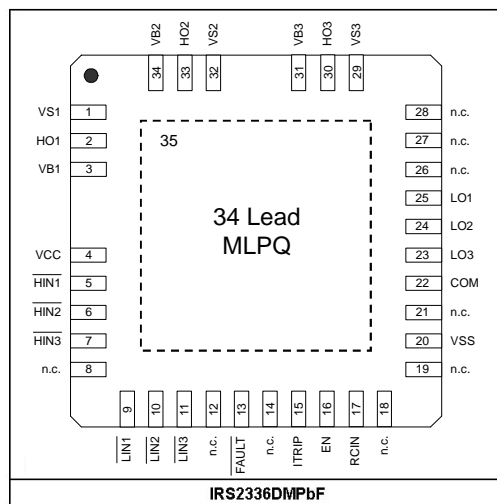
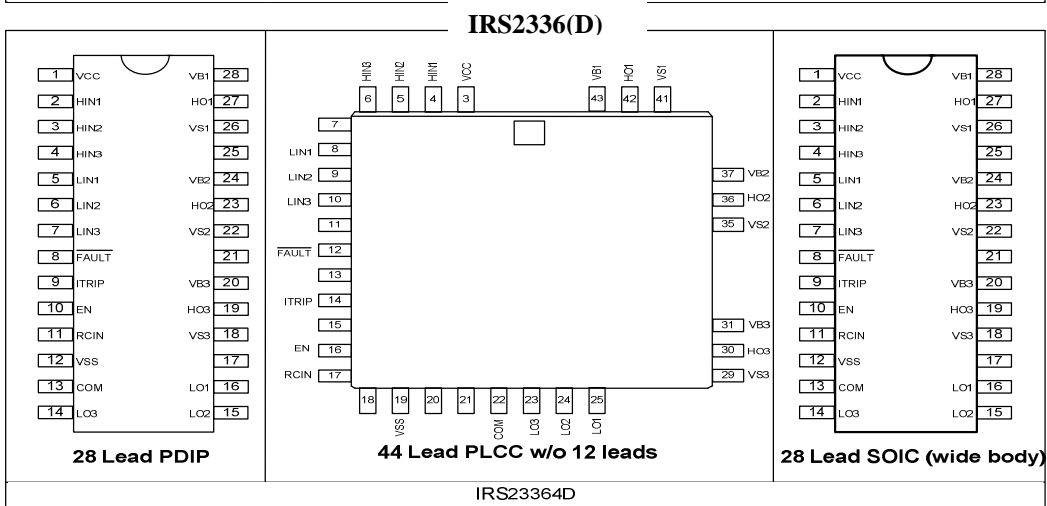
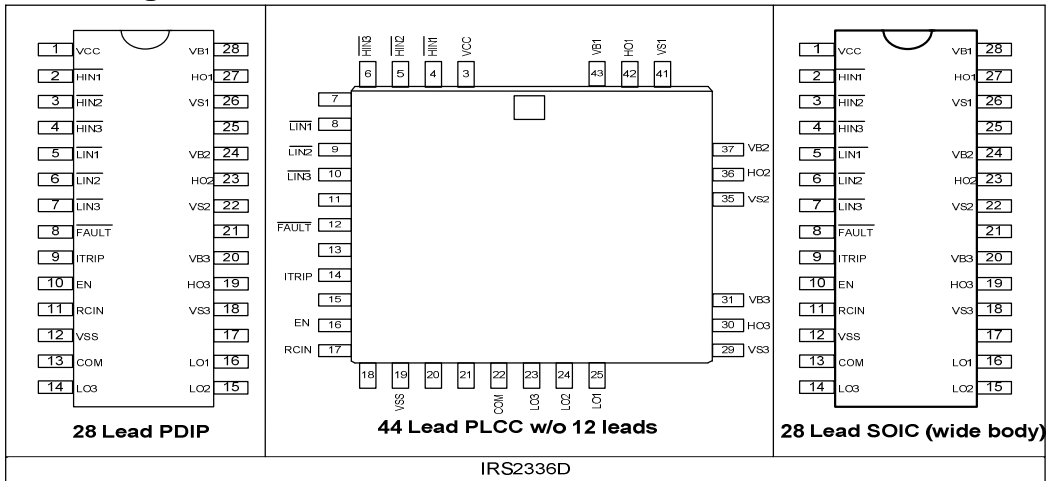

The central exposed pad (35) has to be connected to COM for better electrical performance.

Application Information and Additional Details

Information regarding the following topics are included as subsections within this section of the datasheet.

- IGBT/MOSFET Gate Drive
- Switching and Timing Relationships
- Deadtime
- Matched Propagation Delays
- Input Logic Compatibility
- Undervoltage Lockout Protection
- Shoot-Through Protection
- Enable Input
- Fault Reporting and Programmable Fault Clear Timer
- Over-Current Protection
- Over-Temperature Shutdown Protection
- Truth Table: Undervoltage lockout, ITRIP, and ENABLE
- Advanced Input Filter
- Short-Pulse / Noise Rejection
- Integrated Bootstrap Functionality
- Bootstrap Power Supply Design
- Separate Logic and Power Grounds
- Tolerant to Negative V_s Transients
- PCB Layout Tips
- Integrated Bootstrap FET limitation
- Additional Documentation

IGBT/MOSFET Gate Drive

The IRS2336xD HVICs are designed to drive up to six MOSFET or IGBT power devices. Figures 1 and 2 illustrate several parameters associated with the gate drive functionality of the HVIC. The output current of the HVIC, used to drive the gate of the power switch, is defined as I_O . The voltage that drives the gate of the external power switch is defined as V_{HO} for the high-side power switch and V_{LO} for the low-side power switch; this parameter is sometimes generically called V_{OUT} and in this case does not differentiate between the high-side or low-side output voltage.

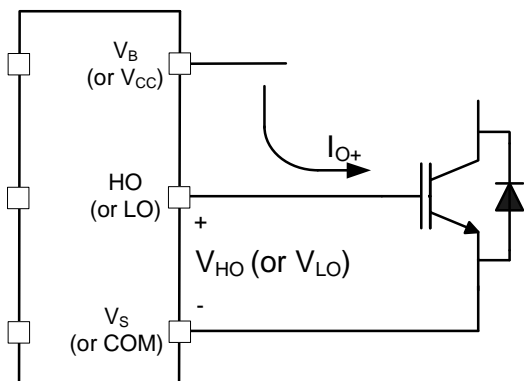

Figure 1: HVIC sourcing current

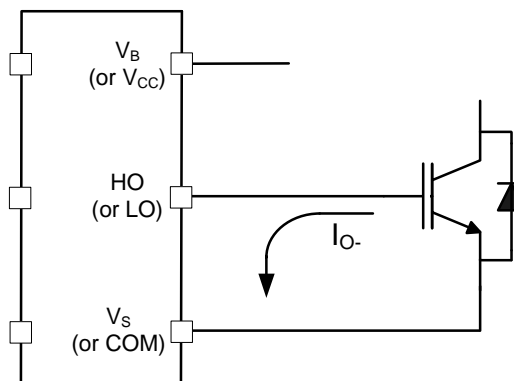

Figure 2: HVIC sinking current

Switching and Timing Relationships

The relationship between the input and output signals of the IRS2336(D) and IRS23364D are illustrated below in Figures 3 and 4. From these figures, we can see the definitions of several timing parameters (i.e., PW_{IN} , PW_{OUT} , t_{ON} , t_{OFF} , t_R , and t_F) associated with this device.

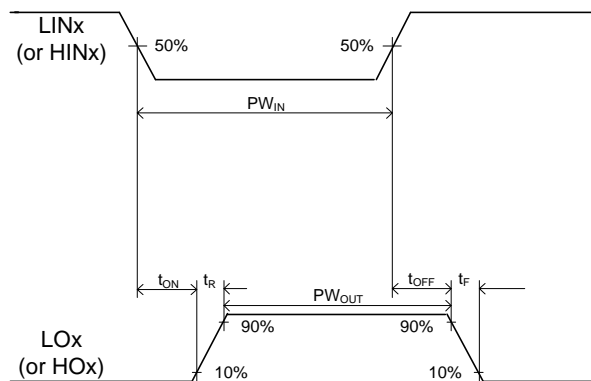

Figure 3: Switching time waveforms (IRS2336(D))

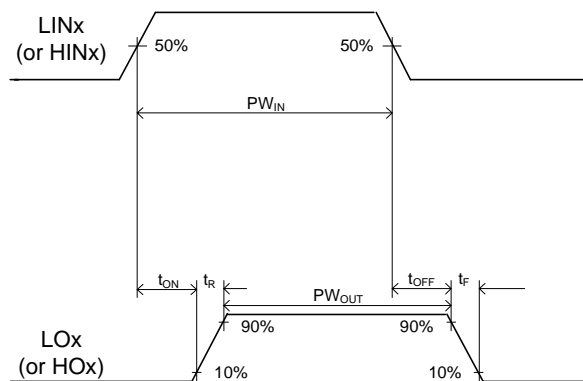

Figure 4: Switching time waveforms (IRS23364D)

The following two figures illustrate the timing relationships of some of the functionality of the IRS2336xD; this functionality is described in further detail later in this document.

During interval A of Figure 5, the HVIC has received the command to turn-on both the high- and low-side switches at the same time; as a result, the shoot-through protection of the HVIC has prevented this condition and both the high- and low-side output are held in the off state.

Interval B of Figures 5 and 6 shows that the signal on the ITRIP input pin has gone from a low to a high state; as a result, all of the gate drive outputs have been disabled (i.e., see that HOx has returned to the low state; LOx is also held low), the voltage on the RCIN pin has been pulled to 0 V, and a fault is reported by the FAULT output transitioning to the low state. Once the ITRIP input has returned to the low state, the output will remain disabled and the fault condition reported until the voltage on the RCIN pin charges up to $V_{RCIN,TH}$ (see interval C in Figure 6); the charging characteristics are dictated by the RC network attached to the RCIN pin.

During intervals D and E of Figure 5, we can see that the enable (EN) pin has been pulled low (as is the case when the driver IC has received a command from the control IC to shutdown); this results in the outputs (HOx and LOx) being held in the low state until the enable pin is pulled high.

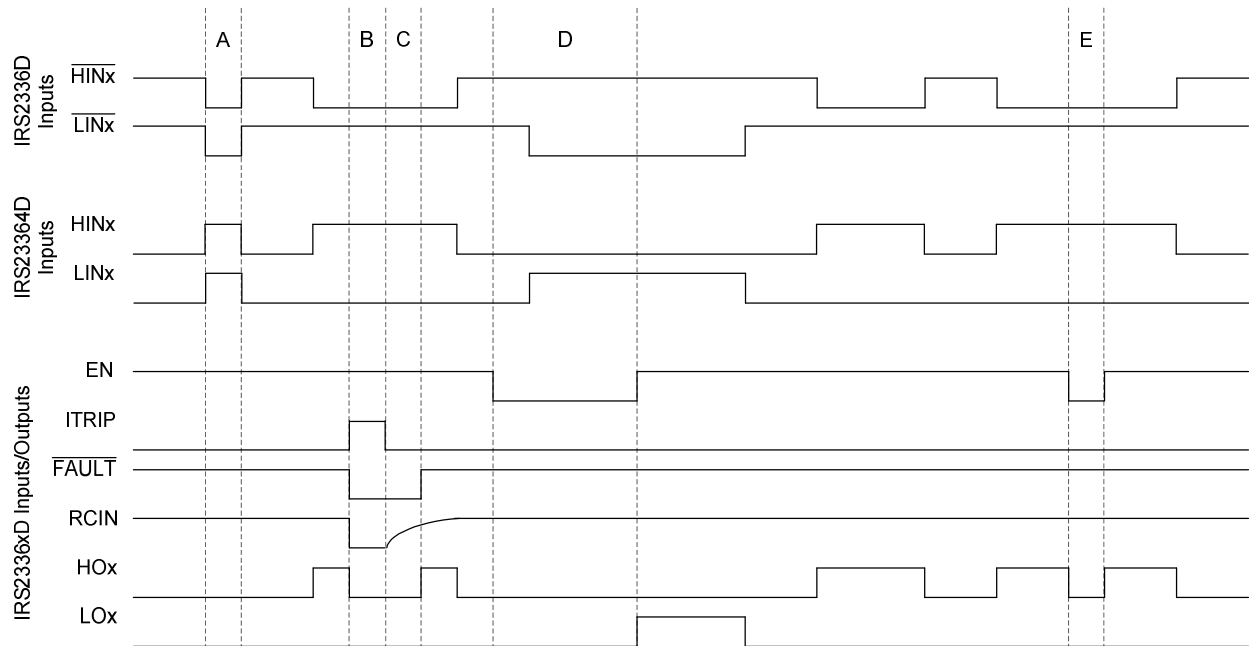

Figure 5: Input/output timing diagram for the IRS2336x(D) family

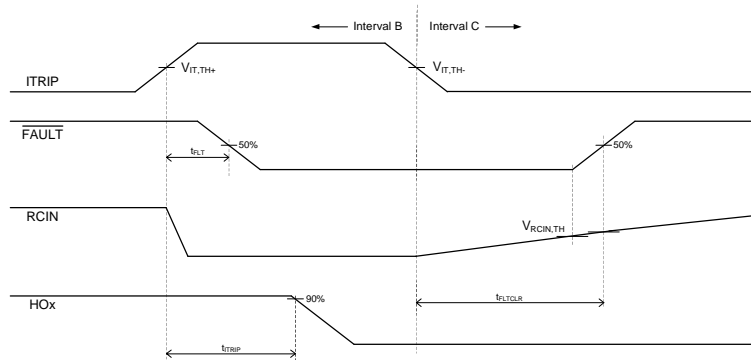

Figure 6: Detailed view of B & C intervals

Deadtime

This family of HVICs features integrated deadtime protection circuitry. The deadtime for these ICs is fixed; other ICs within IR's HVIC portfolio feature programmable deadtime for greater design flexibility. The deadtime feature inserts a time period (a minimum deadtime) in which both the high- and low-side power switches are held off; this is done to ensure that the power switch being turned off has fully turned off before the second power switch is turned on. This minimum deadtime is automatically inserted whenever the external deadtime is shorter than DT; external deadtimes larger than DT are not modified by the gate driver. Figure 7 illustrates the deadtime period and the relationship between the output gate signals.

The deadtime circuitry of the IRS2336xD is matched with respect to the high- and low-side outputs of a given channel; additionally, the deadtimes of each of the three channels are matched. Figure 7 defines the two deadtime parameters (i.e., DT_1 and DT_2) of a specific channel; the deadtime matching parameter (MDT) associated with the IRS2336xD specifies the maximum difference between DT_1 and DT_2 . The MDT parameter also applies when comparing the DT of one channel of the IRS2336xD to that of another.

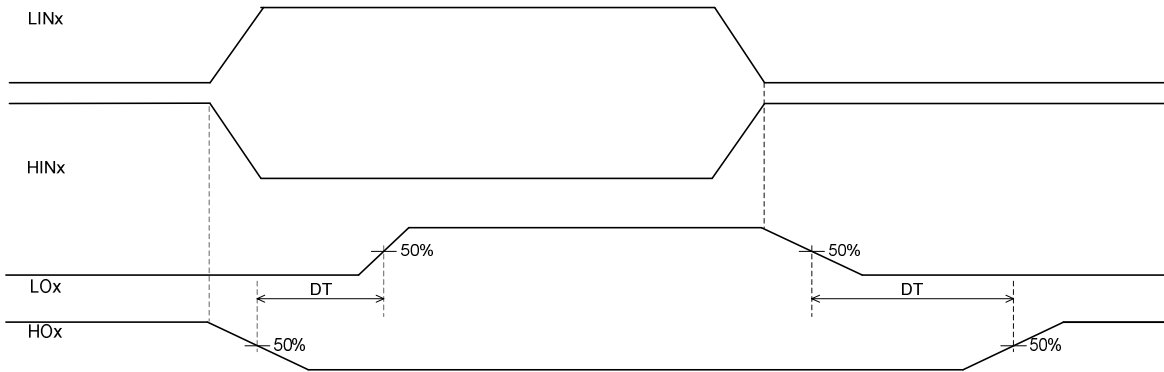

Figure 7: Illustration of deadtime

Matched Propagation Delays

The IRS2336xD family of HVICs is designed with propagation delay matching circuitry. With this feature, the IC's response at the output to a signal at the input requires approximately the same time duration (i.e., t_{ON} , t_{OFF}) for both the low-side channels and the high-side channels; the maximum difference is specified by the delay matching parameter (MT). Additionally, the propagation delay for each low-side channel is matched when compared to the other low-side channels and the propagation delays of the high-side channels are matched with each other; the MT specification applies as well. The propagation turn-on delay (t_{ON}) of the IRS2336xD is matched to the propagation turn-off delay (t_{OFF}).

Input Logic Compatibility

The inputs of this IC are compatible with standard CMOS and TTL outputs. The IRS2336xD family has been designed to be compatible with 3.3 V and 5 V logic-level signals. The IRS2336(D) features an integrated 5.2 V Zener clamp on the HIN, LIN, ITRIP, and EN pins; the IRS23364D does not offer this input clamp. Figure 8 illustrates an input signal to the IRS2336(D) and IRS23364D, its input threshold values, and the logic state of the IC as a result of the input signal.

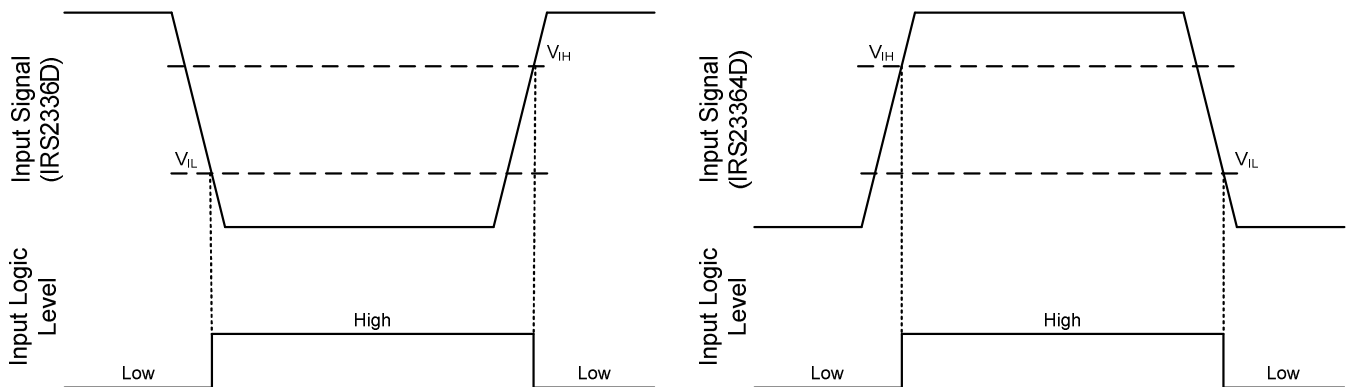

Figure 8: HIN & LIN input thresholds

Undervoltage Lockout Protection

This family of ICs provides undervoltage lockout protection on both the V_{CC} (logic and low-side circuitry) power supply and the V_{BS} (high-side circuitry) power supply. Figure 9 is used to illustrate this concept; V_{CC} (or V_{BS}) is plotted over time and as the waveform crosses the UVLO threshold ($V_{CCUV+/-}$ or $V_{BSUV+/-}$) the undervoltage protection is enabled or disabled.

Upon power-up, should the V_{CC} voltage fail to reach the V_{CCUV+} threshold, the IC will not turn-on. Additionally, if the V_{CC} voltage decreases below the V_{CCUV-} threshold during operation, the undervoltage lockout circuitry will recognize a fault condition and shutdown the high- and low-side gate drive outputs, and the FAULT pin will transition to the low state to inform the controller of the fault condition.

Upon power-up, should the V_{BS} voltage fail to reach the V_{BSUV} threshold, the IC will not turn-on. Additionally, if the V_{BS} voltage decreases below the V_{BSUV} threshold during operation, the undervoltage lockout circuitry will recognize a fault condition, and shutdown the high-side gate drive outputs of the IC.

The UVLO protection ensures that the IC drives the external power devices only when the gate supply voltage is sufficient to fully enhance the power devices. Without this feature, the gates of the external power switch could be driven with a low voltage, resulting in the power switch conducting current while the channel impedance is high; this could result in very high conduction losses within the power device and could lead to power device failure.

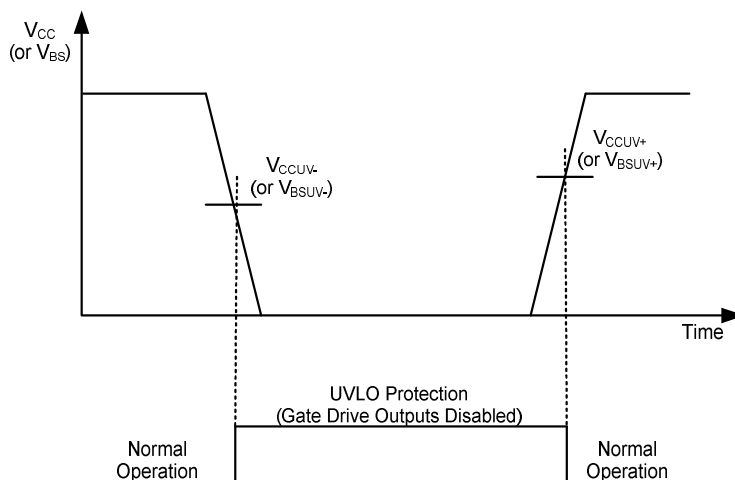

Figure 9: UVLO protection

Shoot-Through Protection

The IRS2336xD family of high-voltage ICs is equipped with shoot-through protection circuitry (also known as cross-conduction prevention circuitry). Figure 10 shows how this protection circuitry prevents both the high- and low-side switches from conducting at the same time. Table 1 illustrates the input/output relationship of the devices in the form of a truth table. Note that the IRS2336(D) has inverting inputs (the output is out-of-phase with its respective input) while the IRS23364D has non-inverting inputs (the output is in-phase with its respective input).

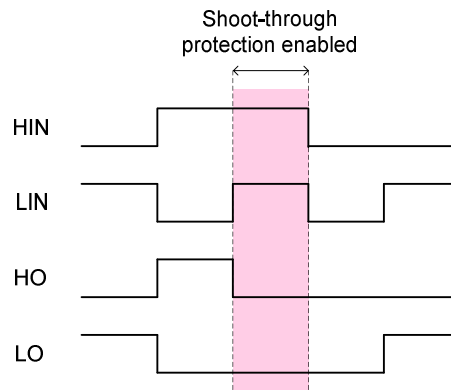

Figure 10: Illustration of shoot-through protection circuitry

IRS2336(D)				IRS23364D			
HIN	LIN	HO	LO	HIN	LIN	HO	LO
0	0	0	0	0	0	0	0
0	1	1	0	0	1	0	1
1	0	0	1	1	0	1	0
1	1	0	0	1	1	0	0

Table 1: Input/output truth table for IRS2336D and IRS23364D

Enable Input

The IRS2336xD family of HVICs is equipped with an enable input pin that is used to shutdown or enable the HVIC. When the EN pin is in the high state the HVIC is able to operate normally (assuming no other fault conditions). When a condition occurs that should shutdown the HVIC, the EN pin should see a low logic state. The enable circuitry of the IRS2336xD features an input filter; the minimum input duration is specified by $t_{FILTER,EN}$. Please refer to the EN pin parameters $V_{EN,TH+}$, $V_{EN,TH-}$, and I_{EN} for the details of its use. Table 2 gives a summary of this pin's functionality and Figure 11 illustrates the outputs' response to a shutdown command.

Enable Input	
Enable input high	Outputs enabled*
Enable input low	Outputs disabled

Table 2: Enable functionality truth table
(*assumes no other fault condition)

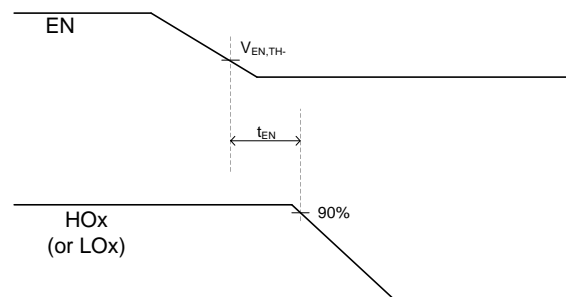

Figure 11: Output enable timing waveform

Fault Reporting and Programmable Fault Clear Timer

The IRS2336xD family provides an integrated fault reporting output and an adjustable fault clear timer. There are two situations that would cause the HVIC to report a fault via the FAULT pin. The first is an undervoltage condition of V_{CC} and the second is if the ITRIP pin recognizes a fault. Once the fault condition occurs, the FAULT pin is internally pulled to V_{SS} and the fault clear timer is activated. The fault output stays in the low state until the fault condition has been removed and the fault clear timer expires; once the fault clear timer expires, the voltage on the FAULT pin will return to V_{CC} .

The length of the fault clear time period (t_{FLTCLR}) is determined by exponential charging characteristics of the capacitor where the time constant is set by R_{RCIN} and C_{RCIN} . In Figure 12 where we see that a fault condition has occurred (UVLO or ITRIP), $RCIN$ and $FAULT$ are pulled to V_{SS} , and once the fault has been removed, the fault clear timer begins. Figure 13 shows that R_{RCIN} is connected between the V_{CC} and the $RCIN$ pin, while C_{RCIN} is placed between the $RCIN$ and V_{SS} pins.

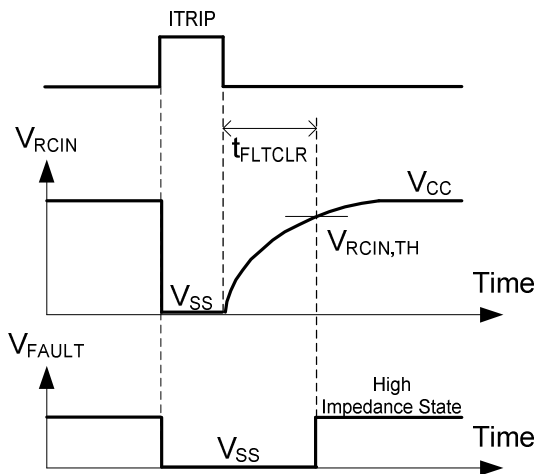

Figure 12: RCIN and FAULT pin waveforms

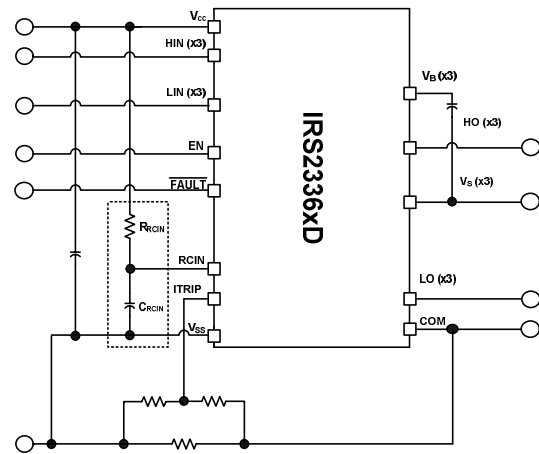

Figure 13: Programming the fault clear timer

The design guidelines for this network are shown in Table 3.

C_{RCIN}	≤ 1 nF
	Ceramic
R_{RCIN}	0.5 M Ω to 2 M Ω
	$\gg R_{ON,RCIN}$

Table 3: Design guidelines

The length of the fault clear time period can be determined by using the formula below.

$$v_C(t) = V_i(1 - e^{-t/RC})$$

$$t_{FLTCLR} = -(R_{RCIN}C_{RCIN})\ln(1 - V_{RCIN,TH}/V_{CC})$$

Over-Current Protection

The IRS2336xD HVICs are equipped with an ITRIP input pin. This functionality can be used to detect over-current events in the DC- bus. Once the HVIC detects an over-current event through the ITRIP pin, the outputs are shutdown, a fault is reported through the FAULT pin, and RCIN is pulled to V_{SS}.

The level of current at which the over-current protection is initiated is determined by the resistor network (i.e., R₀, R₁, and R₂) connected to ITRIP as shown in Figure 14, and the ITRIP threshold (V_{IT,TH+}). The circuit designer will need to determine the maximum allowable level of current in the DC- bus and select R₀, R₁, and R₂ such that the voltage at node V_X reaches the over-current threshold (V_{IT,TH+}) at that current level.

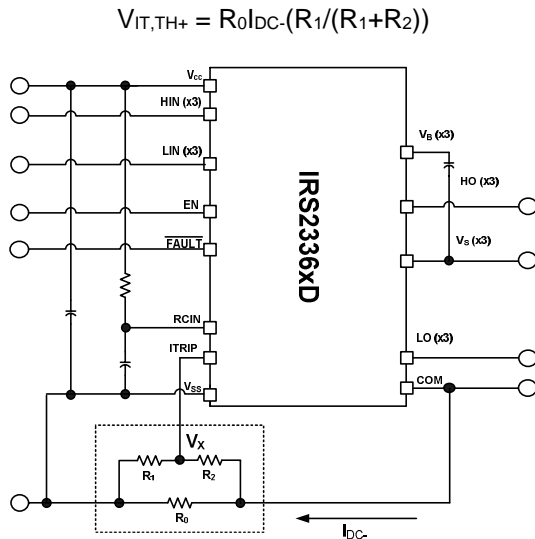

Figure 14: Programming the over-current protection

For example, a typical value for resistor R₀ could be 50 mΩ. The voltage of the ITRIP pin should not be allowed to exceed 5 V; if necessary, an external voltage clamp may be used.

Over-Temperature Shutdown Protection

The ITRIP input of the IRS2336xD can also be used to detect over-temperature events in the system and initiate a shutdown of the HVIC (and power switches) at that time. In order to use this functionality, the circuit designer will need to design the resistor network as shown in Figure 15 and select the maximum allowable temperature.

This network consists of a thermistor and two standard resistors R₃ and R₄. As the temperature changes, the resistance of the thermistor will change; this will result in a change of voltage at node V_X. The resistor values should be selected such the voltage V_X should reach the threshold voltage (V_{IT,TH+}) of the ITRIP functionality by the time that the maximum allowable temperature is reached. The voltage of the ITRIP pin should not be allowed to exceed 5 V.

When using both the over-current protection and over-temperature protection with the ITRIP input, OR-ing diodes (e.g., DL4148) can be used. This network is shown in Figure 16; the OR-ing diodes have been labeled D₁ and D₂.

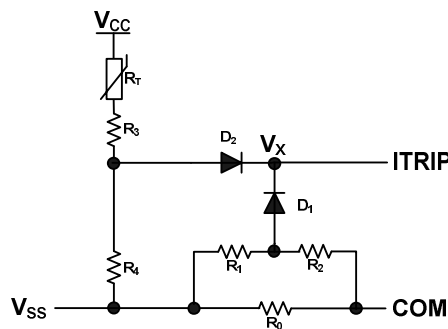
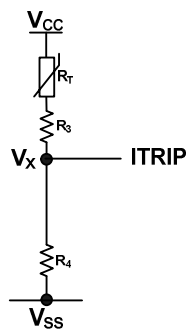

Figure 15: Programming over-temperature protection **Figure 16: Using over-current protection and over-temperature protection**

Truth Table: Undervoltage lockout, ITRIP, and ENABLE

Table 4 provides the truth table for the IRS2336xD. The first line shows that the UVLO for V_{CC} has been tripped; the FAULT output has gone low and the gate drive outputs have been disabled. V_{CCUV} is not latched in this case and when V_{CC} is greater than V_{CCUV} , the FAULT output returns to the high impedance state.

The second case shows that the UVLO for V_{BS} has been tripped and that the high-side gate drive outputs have been disabled. After V_{BS} exceeds the V_{BSUV} threshold, HO will stay low until the HVIC input receives a new falling (IRS2336(D)) or rising (IRS23364D) transition of HIN. The third case shows the normal operation of the HVIC. The fourth case illustrates that the ITRIP trip threshold has been reached and that the gate drive outputs have been disabled and a fault has been reported through the fault pin. In the last case, the HVIC has received a command through the EN input to shutdown; as a result, the gate drive outputs have been disabled.

	VCC	VBS	ITRIP	EN	RCIN	FAULT	LO	HO
UVLO V_{CC}	$<V_{CCUV}$	—	—	—	High	0	0	0
UVLO V_{BS}	15 V	$<V_{BSUV}$	0 V	5 V	High	High impedance	LIN	0
Normal operation	15 V	15 V	0 V	5 V	High	High impedance	LIN	HIN
ITRIP fault	15 V	15 V	$>V_{ITRIP}$	5 V	Low	0	0	0
EN command	15 V	15 V	0 V	0 V	High	High impedance	0	0

Table 4: IRS2336xD UVLO, ITRIP, EN, RCIN, & FAULT truth table

Advanced Input Filter

The advanced input filter allows an improvement in the input/output pulse symmetry of the HVIC and helps to reject noise spikes and short pulses. This input filter has been applied to the HIN, LIN, and EN inputs. The working principle of the new filter is shown in Figures 17 and 18.

Figure 17 shows a typical input filter and the asymmetry of the input and output. The upper pair of waveforms (Example 1) show an input signal with a duration much longer than $t_{FIL,IN}$; the resulting output is approximately the difference between the input signal and $t_{FIL,IN}$. The lower pair of waveforms (Example 2) show an input signal with a duration slightly longer than $t_{FIL,IN}$; the resulting output is approximately the difference between the input signal and $t_{FIL,IN}$.

Figure 18 shows the advanced input filter and the symmetry between the input and output. The upper pair of waveforms (Example 1) show an input signal with a duration much longer than $t_{FIL,IN}$; the resulting output is approximately the same duration as the input signal. The lower pair of waveforms (Example 2) show an input signal with a duration slightly longer than $t_{FIL,IN}$; the resulting output is approximately the same duration as the input signal.

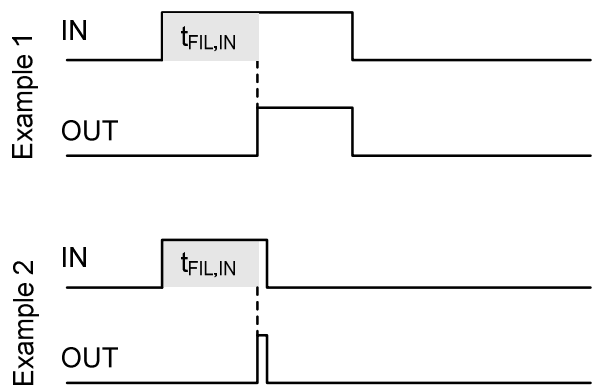

Figure 17: Typical input filter

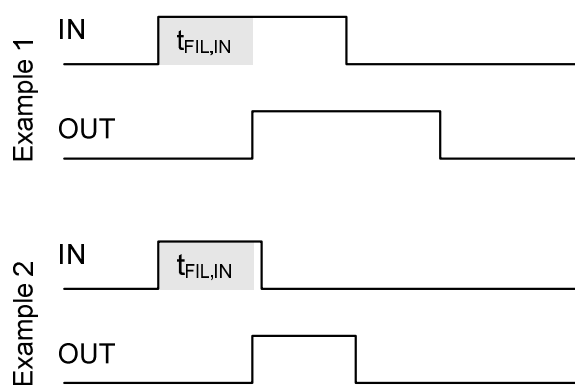

Figure 18: Advanced input filter

Short-Pulse / Noise Rejection

This device's input filter provides protection against short-pulses (e.g., noise) on the input lines. If the duration of the input signal is less than $t_{FIL,IN}$, the output will not change states. Example 1 of Figure 19 shows the input and output in the low state with positive noise spikes of durations less than $t_{FIL,IN}$; the output does not change states. Example 2 of Figure 19 shows the input and output in the high state with negative noise spikes of durations less than $t_{FIL,IN}$; the output does not change states.

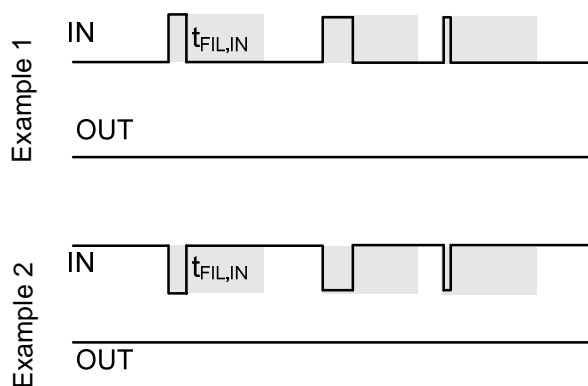

Figure 19: Noise rejecting input filters

Figures 20 and 21 present lab data that illustrates the characteristics of the input filters while receiving ON and OFF pulses.

The input filter characteristic is shown in Figure 20; the left side illustrates the narrow pulse ON (short positive pulse) characteristic while the left shows the narrow pulse OFF (short negative pulse) characteristic. The x-axis of Figure 20 shows the duration of PW_{IN} , while the y-axis shows the resulting PW_{OUT} duration. It can be seen that for a PW_{IN} duration less than $t_{FIL,IN}$, that the resulting PW_{OUT} duration is zero (e.g., the filter rejects the input signal/noise). We also see that once the PW_{IN} duration exceed $t_{FIL,IN}$, that the PW_{OUT} durations mimic the PW_{IN} durations very well over this interval with the symmetry improving as the duration increases. To ensure proper operation of the HVIC, it is suggested that the input pulse width for the high-side inputs be ≥ 500 ns.

The difference between the PW_{OUT} and PW_{IN} signals of both the narrow ON and narrow OFF cases is shown in Figure 21; the careful reader will note the scale of the y-axis. The x-axis of Figure 21 shows the duration of PW_{IN} , while the y-axis shows the resulting $PW_{OUT}-PW_{IN}$ duration. This data illustrates the performance and near symmetry of this input filter.

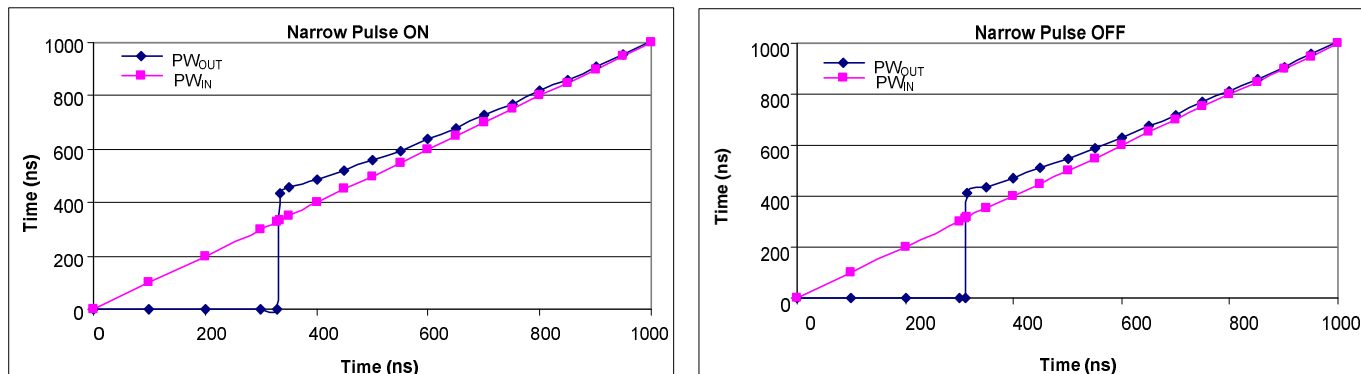

Figure 20: IRS2336xD input filter characteristic

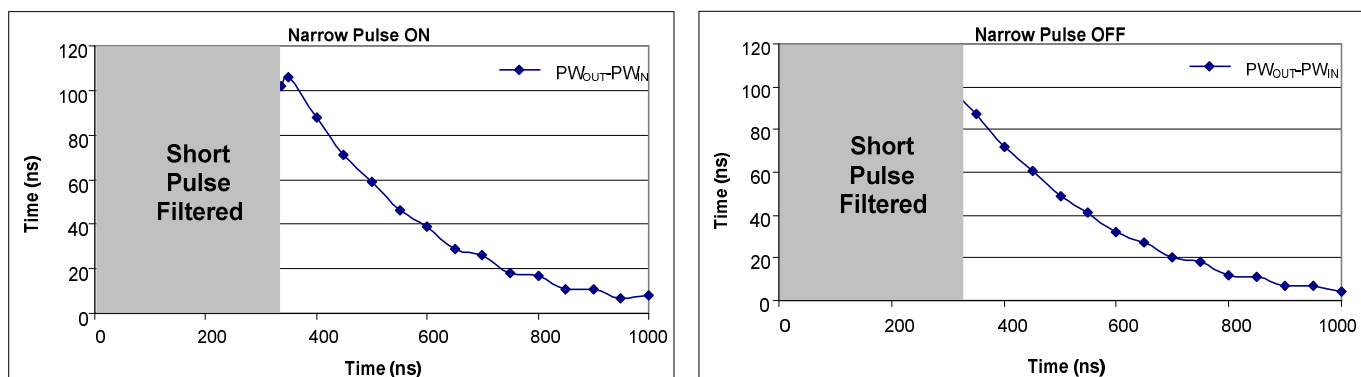

Figure 21: Difference between the input pulse and the output pulse

Integrated Bootstrap Functionality

The new IRS2336xD family features integrated high-voltage bootstrap MOSFETs that eliminate the need of the external bootstrap diodes and resistors in many applications.

There is one bootstrap MOSFET for each high-side output channel and it is connected between the V_{CC} supply and its respective floating supply (i.e., V_{B1} , V_{B2} , V_{B3}); see Figure 22 for an illustration of this internal connection.

The integrated bootstrap MOSFET is turned on only during the time when LO is 'high', and it has a limited source current due to R_{BS} . The V_{BS} voltage will be charged each cycle depending on the on-time of LO and the value of the C_{BS} capacitor, the drain-source (collector-emitter) drop of the external IGBT (or MOSFET), and the low-side free-wheeling diode drop.

The bootstrap MOSFET of each channel follows the state of the respective low-side output stage (i.e., the bootstrap MOSFET is ON when LO is high, it is OFF when LO is low), unless the V_B voltage is higher than approximately 110% of V_{CC} . In that case, the bootstrap MOSFET is designed to remain off until V_B returns below that threshold; this concept is illustrated in Figure 23.

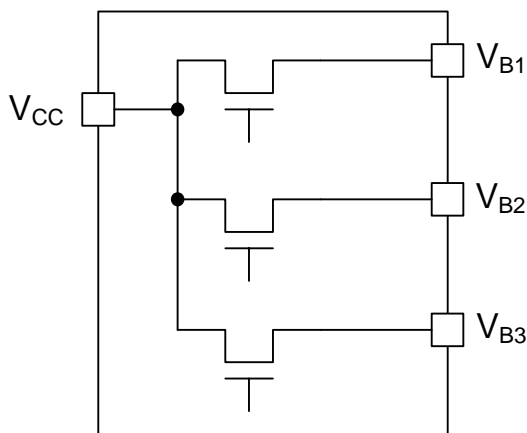

Figure 22: Internal bootstrap MOSFET connection

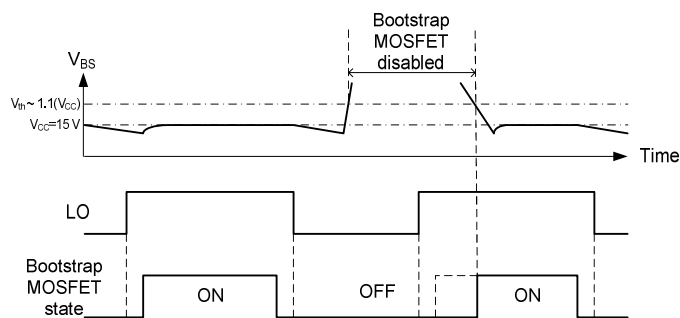

Figure 23: Bootstrap MOSFET state diagram

A bootstrap MOSFET is suitable for most of the PWM modulation schemes and can be used either in parallel with the external bootstrap network (i.e., diode and resistor) or as a replacement of it. The use of the integrated bootstrap as a replacement of the external bootstrap network may have some limitations. An example of this limitation may arise when this functionality is used in non-complementary PWM schemes (typically 6-step modulations) and at very high PWM duty cycle. In these cases, superior performances can be achieved by using an external bootstrap diode in parallel with the internal bootstrap network.

Bootstrap Power Supply Design

For information related to the design of the bootstrap power supply while using the integrated bootstrap functionality of the IRS2336xD family, please refer to Application Note 1123 (AN-1123) entitled “Bootstrap Network Analysis: Focusing on the Integrated Bootstrap Functionality.” This application note is available at www.irf.com.

For information related to the design of a standard bootstrap power supply (i.e., using an external discrete diode) please refer to Design Tip 04-4 (DT04-4) entitled “Using Monolithic High Voltage Gate Drivers.” This design tip is available at www.irf.com.

Separate Logic and Power Grounds

The IRS2336xD has separate logic and power ground pin (V_{SS} and COM respectively) to eliminate some of the noise problems that can occur in power conversion applications. Current sensing shunts are commonly used in many applications for power inverter protection (i.e., over-current protection), and in the case of motor drive applications, for motor current measurements. In these situations, it is often beneficial to separate the logic and power grounds.

Figure 24 shows a HVIC with separate V_{SS} and COM pins and how these two grounds are used in the system. The V_{SS} is used as the reference point for the logic and over-current circuitry; V_X in the figure is the voltage between the ITRIP pin and the V_{SS} pin. Alternatively, the COM pin is the reference point for the low-side gate drive circuitry. The output voltage used to drive the low-side gate is V_{LO-COM} ; the gate-emitter voltage (V_{GE}) of the low-side switch is the output voltage of the driver minus the drop across $R_{G,LO}$.

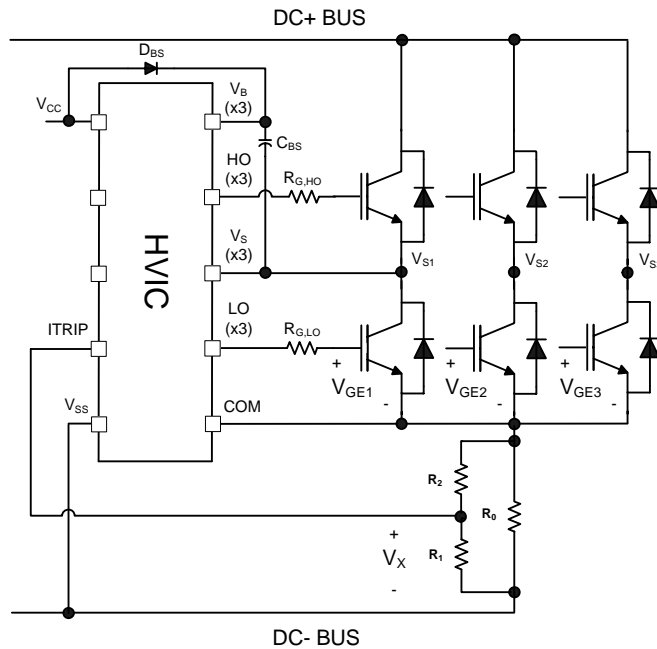

Figure 24: Separate V_{SS} and COM pins

Tolerant to Negative V_S Transients

A common problem in today's high-power switching converters is the transient response of the switch node's voltage as the power switches transition on and off quickly while carrying a large current. A typical 3-phase inverter circuit is shown in Figure 25; here we define the power switches and diodes of the inverter.

If the high-side switch (e.g., the IGBT Q1 in Figures 26 and 27) switches off, while the U phase current is flowing to an inductive load, a current commutation occurs from high-side switch (Q1) to the diode (D2) in parallel with the low-side switch of the same inverter leg. At the same instance, the voltage node V_{S1} , swings from the positive DC bus voltage to the negative DC bus voltage.

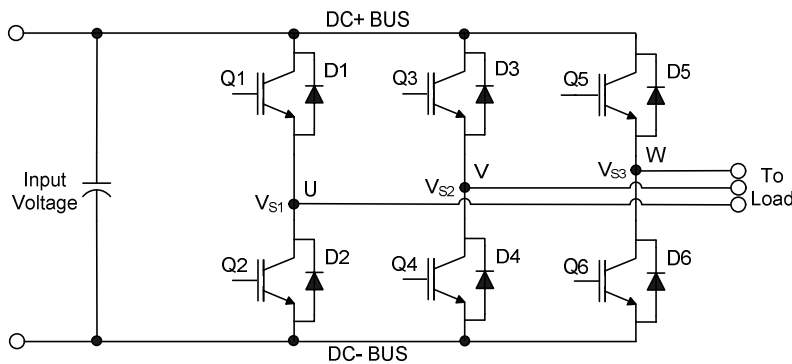

Figure 25: Three phase inverter

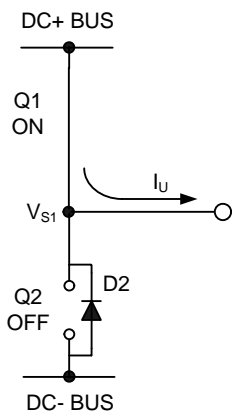

Figure 26: Q1 conducting

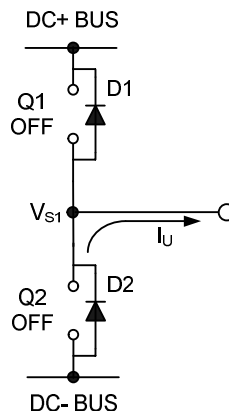

Figure 27: D2 conducting

Also when the V phase current flows from the inductive load back to the inverter (see Figures 28 and 29), and Q4 IGBT switches on, the current commutation occurs from D3 to Q4. At the same instance, the voltage node, V_{S2} , swings from the positive DC bus voltage to the negative DC bus voltage.

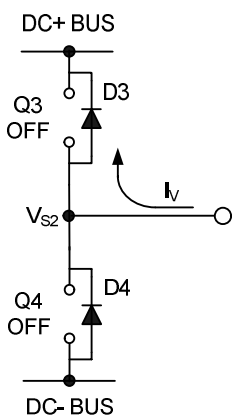

Figure 28: D3 conducting

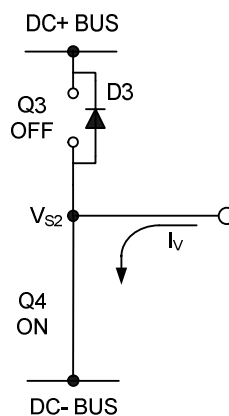

Figure 29: Q4 conducting

However, in a real inverter circuit, the V_s voltage swing does not stop at the level of the negative DC bus, rather it swings below the level of the negative DC bus. This undershoot voltage is called “negative V_s transient”.

The circuit shown in Figure 30 depicts one leg of the three phase inverter; Figures 31 and 32 show a simplified illustration of the commutation of the current between Q1 and D2. The parasitic inductances in the power circuit from the die bonding to the PCB tracks are lumped together in L_C and L_E for each IGBT. When the high-side switch is on, V_{S1} is below the DC+ voltage by the voltage drops associated with the power switch and the parasitic elements of the circuit. When the high-side power switch turns off, the load current momentarily flows in the low-side freewheeling diode due to the inductive load connected to V_{S1} (the load is not shown in these figures). This current flows from the DC- bus (which is connected to the COM pin of the HVIC) to the load and a negative voltage between V_{S1} and the DC- Bus is induced (i.e., the COM pin of the HVIC is at a higher potential than the V_s pin).

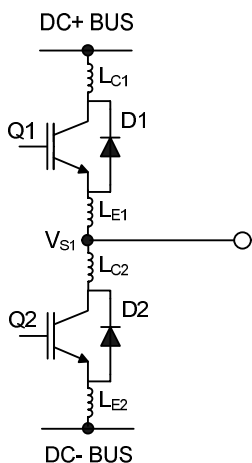

Figure 30: Parasitic Elements

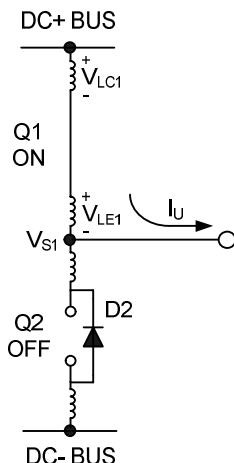

Figure 31: V_s positive

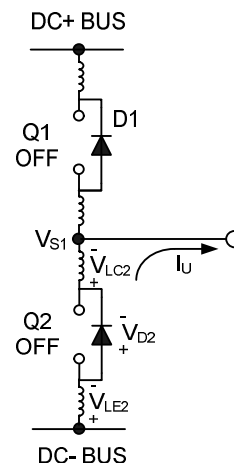

Figure 32: V_s negative

In a typical motor drive system, dV/dt is typically designed to be in the range of 3-5 V/ns. The negative V_s transient voltage can exceed this range during some events such as short circuit and over-current shutdown, when di/dt is greater than in normal operation.

International Rectifier's HVICs have been designed for the robustness required in many of today's demanding applications. The IRS2336xD has been seen to withstand large negative V_s transient conditions on the order of -50 V for a period of 50 ns. An illustration of the IRS2336D's performance can be seen in Figure 33. This experiment was conducted using various loads to create this condition; the curve shown in this figure illustrates the successful operation of the IRS2336D under these stressful conditions. In case of $-V_s$ transients greater than -20 V for a period of time greater than 100 ns; the HVIC is designed to hold the high-side outputs in the off state for 4.5 μ s in order to ensure that the high- and low-side power switches are not on at the same time.

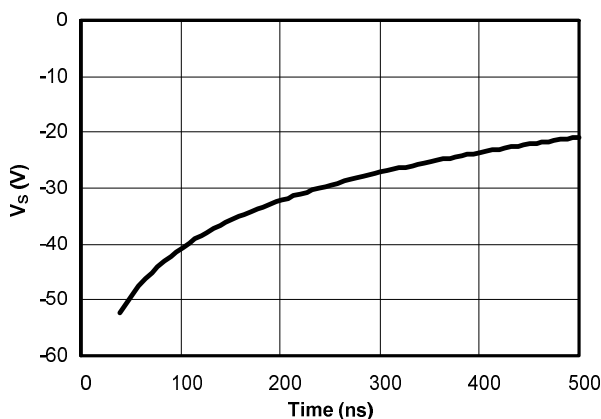

Figure 33: Negative V_s transient results for an International Rectifier HVIC

Even though the IRS2336xD has been shown able to handle these large negative V_s transient conditions, it is highly recommended that the circuit designer always limit the negative V_s transients as much as possible by careful PCB layout and component use.

PCB Layout Tips

Distance between high and low voltage components: It's strongly recommended to place the components tied to the floating voltage pins (V_B and V_S) near the respective high voltage portions of the device. The IRS2336xD in the PLCC44 package has had some unused pins removed in order to maximize the distance between the high voltage and low voltage pins. Please see the Case Outline PLCC44 information in this datasheet for the details.

Ground Plane: In order to minimize noise coupling, the ground plane should not be placed under or near the high voltage floating side. For IRS2336DM the central exposed pad has to be connected to COM for better electrical performance.

Gate Drive Loops: Current loops behave like antennas and are able to receive and transmit EM noise (see Figure 34). In order to reduce the EM coupling and improve the power switch turn on/off performance, the gate drive loops must be reduced as much as possible. Moreover, current can be injected inside the gate drive loop via the IGBT collector-to-gate parasitic capacitance. The parasitic auto-inductance of the gate loop contributes to developing a voltage across the gate-emitter, thus increasing the possibility of a self turn-on effect.

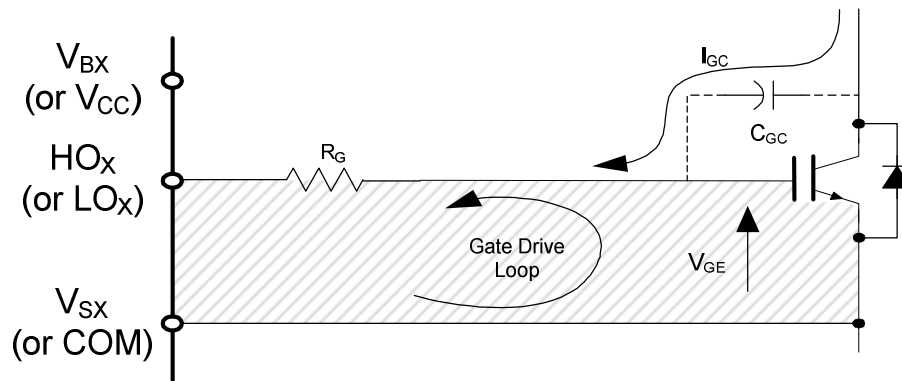

Figure 34: Antenna Loops

Supply Capacitor: It is recommended to place a bypass capacitor (C_{IN}) between the V_{CC} and V_{SS} pins. This connection is shown in Figure 35. A ceramic 1 μF ceramic capacitor is suitable for most applications. This component should be placed as close as possible to the pins in order to reduce parasitic elements.

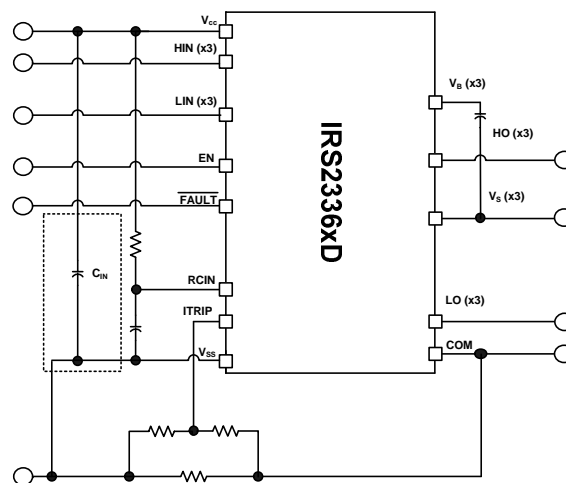

Figure 35: Supply capacitor

Routing and Placement: Power stage PCB parasitic elements can contribute to large negative voltage transients at the switch node; it is recommended to limit the phase voltage negative transients. In order to avoid such conditions, it is recommended to 1) minimize the high-side emitter to low-side collector distance, and 2) minimize the low-side emitter to negative bus rail stray inductance. However, where negative V_s spikes remain excessive, further steps may be taken to reduce the spike. This includes placing a resistor (5 Ω or less) between the V_s pin and the switch node (see Figure 36), and in some cases using a clamping diode between V_{ss} and V_s (see Figure 37). See DT04-4 at www.irf.com for more detailed information.

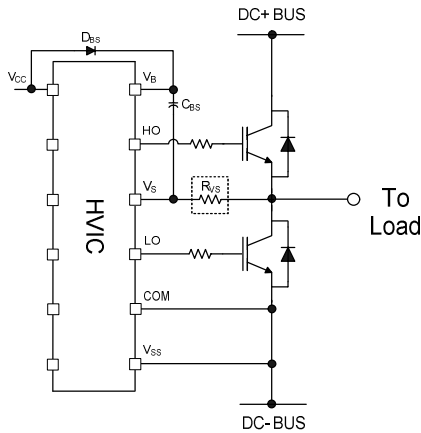

Figure 36: V_s resistor

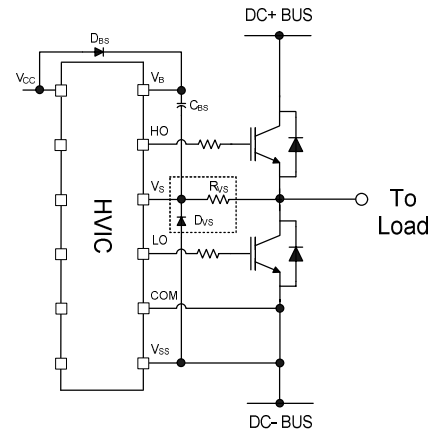

Figure 37: V_s clamping diode

Integrated Bootstrap FET limitation

The integrated Bootstrap FET functionality has an operational limitation under the following bias conditions applied to the HVIC:

- **VCC pin voltage = 0V AND**
- **VS or VB pin voltage > 0**

In the absence of a VCC bias, the integrated bootstrap FET voltage blocking capability is compromised and a current conduction path is created between VCC & VB pins, as illustrated in Fig.38 below, resulting in power loss and possible damage to the HVIC.

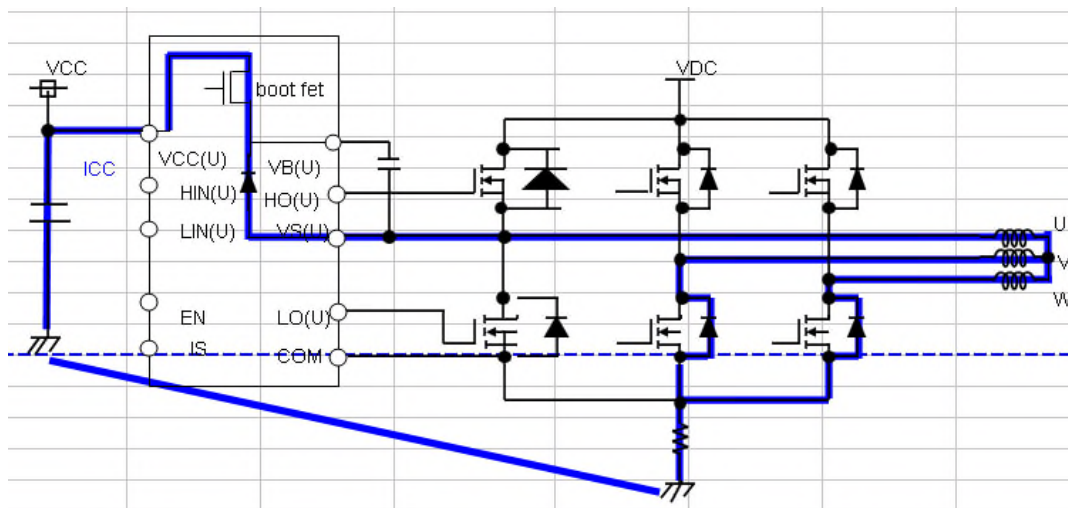

Figure 38: Current conduction path between VCC and VB pin

Relevant Application Situations:

The above mentioned bias condition may be encountered under the following situations:

- In a motor control application, a permanent magnet motor naturally rotating while VCC power is OFF. In this condition, Back EMF is generated at a motor terminal which causes high voltage bias on VS nodes resulting unwanted current flow to VCC.
- Potential situations in other applications where VS/VB node voltage potential increases before the VCC voltage is available (for example due to sequencing delays in SMPS supplying VCC bias)

Application Workaround:

Insertion of a standard p-n junction diode between VCC pin of IC and positive terminal of VCC capacitors (as illustrated in Fig.39) prevents current conduction “out-of” VCC pin of gate driver IC. It is important not to connect the VCC capacitor directly to pin of IC. Diode selection is based on 25V rating or above & current capability aligned to ICC consumption of IC - 100mA should cover most application situations. As an example, Part number # LL4154 from Diodes Inc (25V/150mA standard diode) can be used.

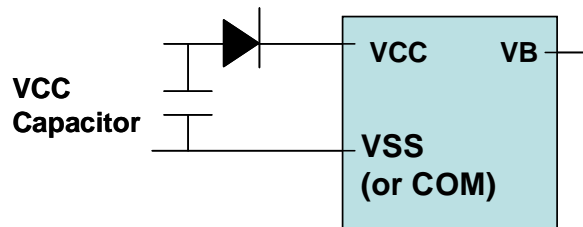

Figure 39: Diode insertion between VCC pin and VCC capacitor

Note that the forward voltage drop on the diode (V_F) must be taken into account when biasing the VCC pin of the IC to meet UVLO requirements. $VCC\ pin\ Bias = VCC\ Supply\ Voltage - V_F\ of\ Diode$.

Additional Documentation

Several technical documents related to the use of HVICs are available at www.irf.com; use the Site Search function and the document number to quickly locate them. Below is a short list of some of these documents.

- DT97-3: Managing Transients in Control IC Driven Power Stages
- AN-1123: Bootstrap Network Analysis: Focusing on the Integrated Bootstrap Functionality
- DT04-4: Using Monolithic High Voltage Gate Drivers
- AN-978: HV Floating MOS-Gate Driver ICs

Parameter Temperature Trends

Figures 40-61 provide information on the experimental performance of the IRS2336xD HVIC. The line plotted in each figure is generated from actual lab data. A small number of individual samples were tested at three temperatures (-40 °C, 25 °C, and 125 °C) in order to generate the experimental (Exp.) curve. The line labeled Exp. consist of three data points (one data point at each of the tested temperatures) that have been connected together to illustrate the understood temperature trend. The individual data points on the curve were determined by calculating the averaged experimental value of the parameter (for a given temperature).

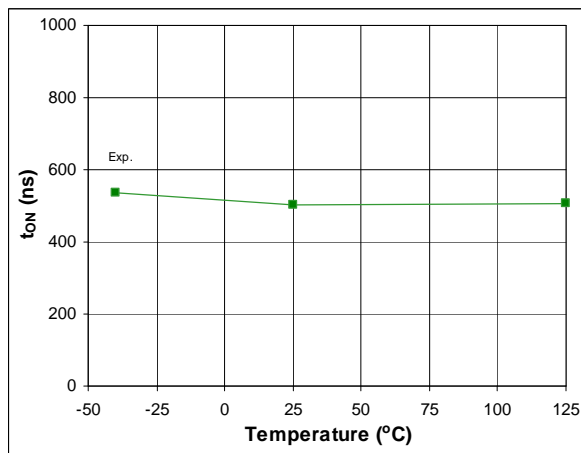

Figure 40: t_{ON} vs. temperature

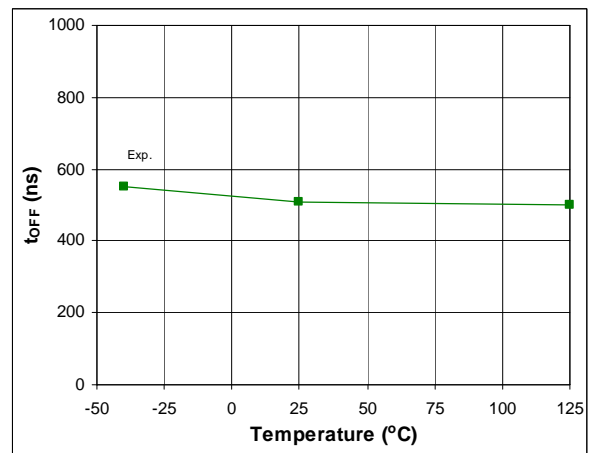

Figure 41: t_{OFF} vs. temperature

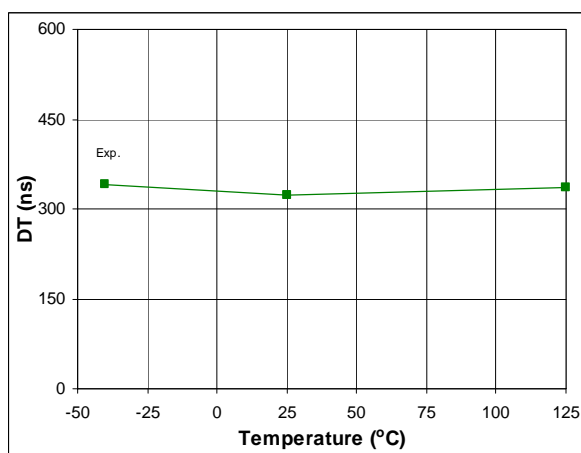

Figure 42: DT vs. temperature

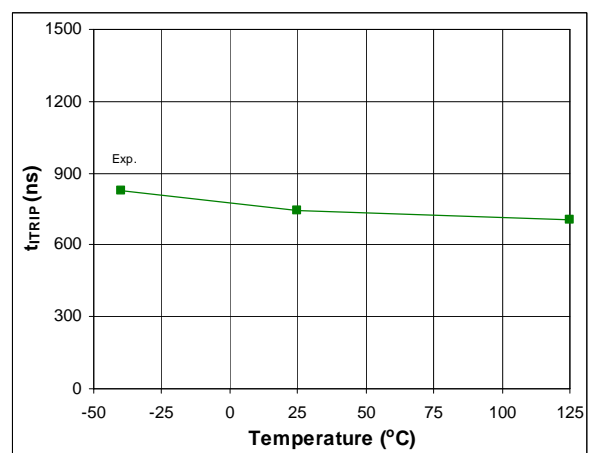

Figure 43: t_{TRIP} vs. temperature

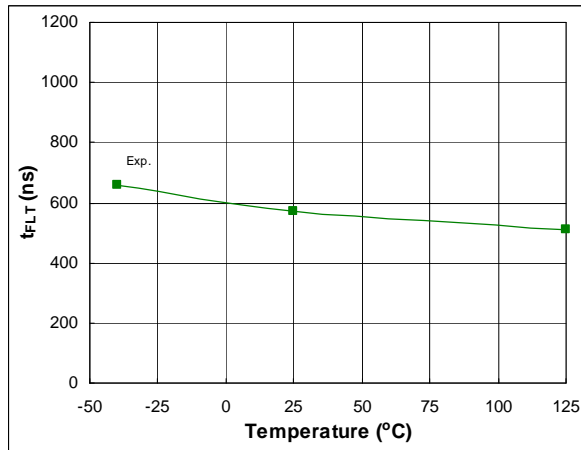

Figure 44: t_{FLT} vs. temperature

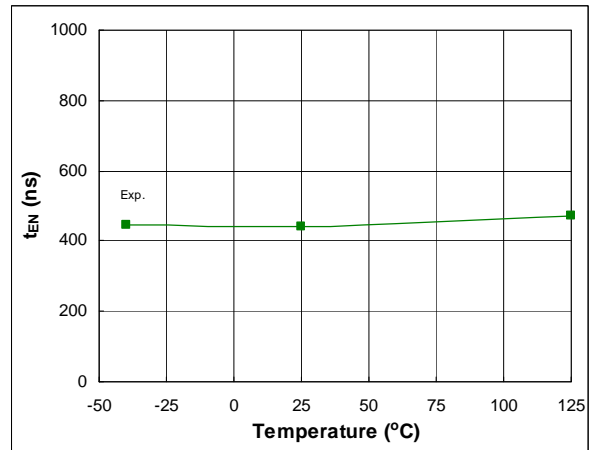

Figure 45: t_{EN} vs. temperature

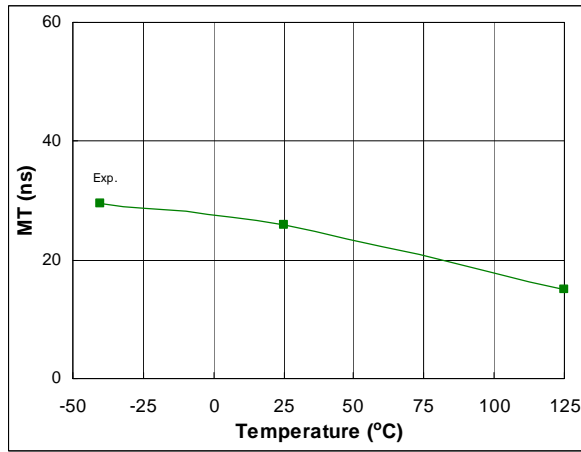

Figure 46: MT vs. temperature

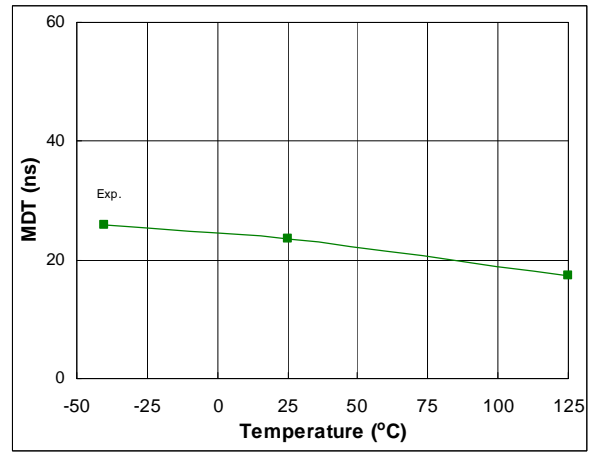

Figure 47: MDT vs. temperature

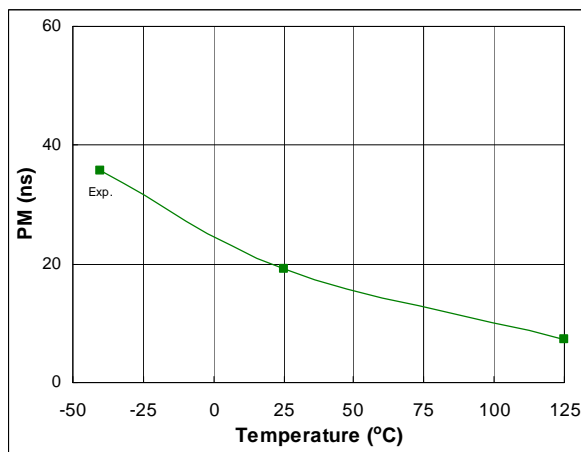

Figure 48: PM vs. temperature

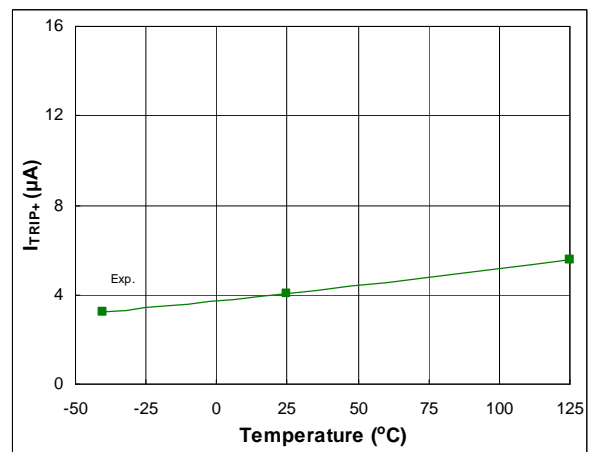

Figure 49: I_{TRIP+} vs. temperature

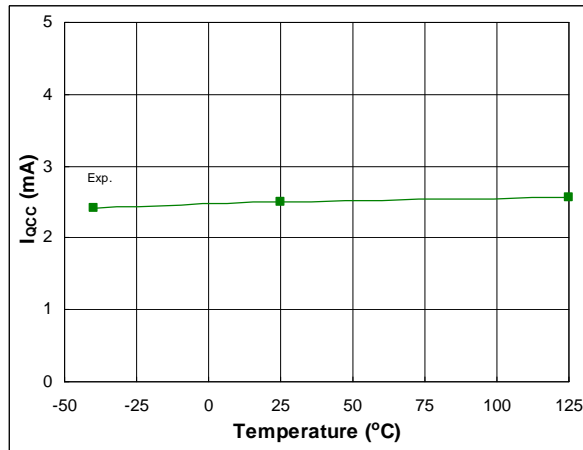

Figure 50: I_{QCC} vs. temperature

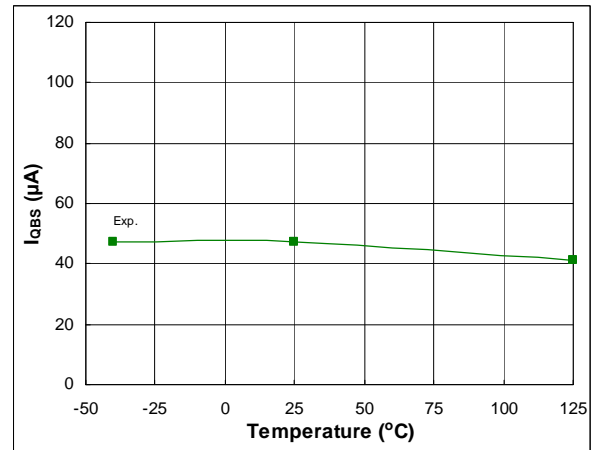

Figure 51: I_{QBS} vs. temperature

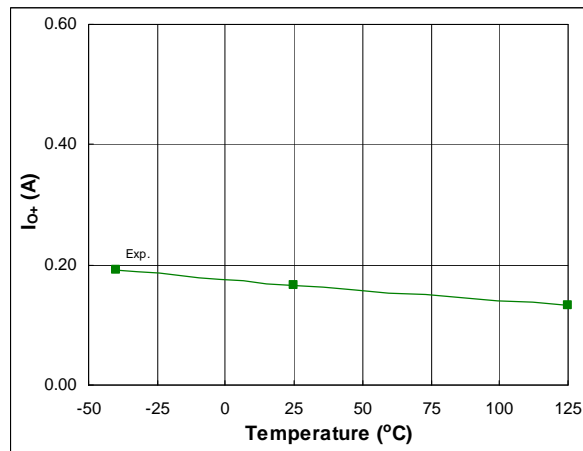

Figure 52: I_{O+} vs. temperature

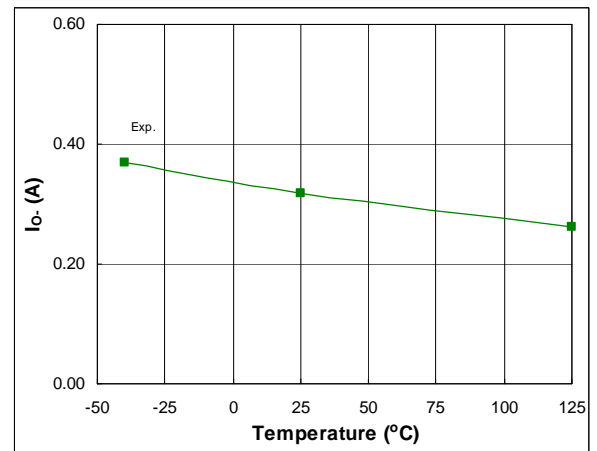

Figure 53: I_{O-} vs. temperature

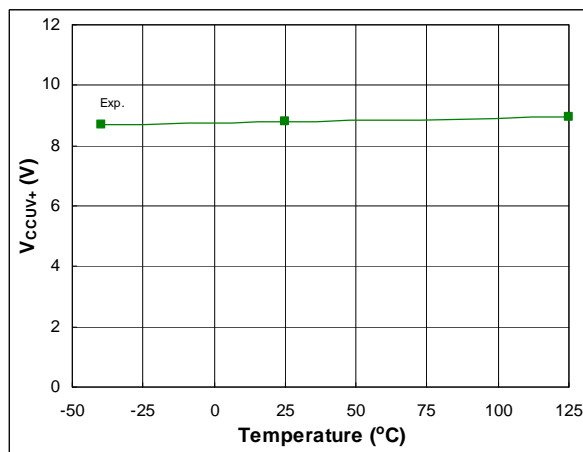

Figure 54: V_{CCUV+} vs. temperature

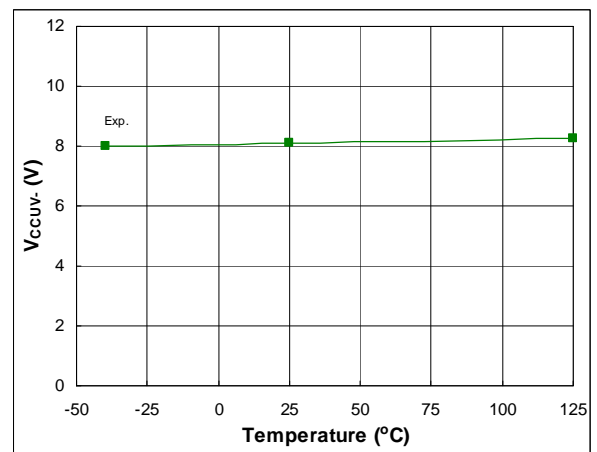

Figure 55: V_{CCUV-} vs. temperature

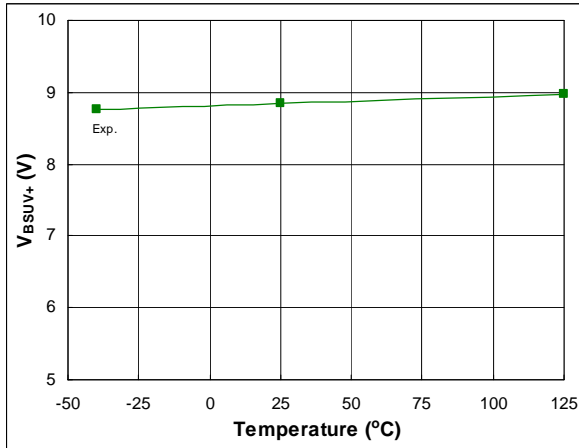

Figure 56: V_{BSUV+} vs. temperature

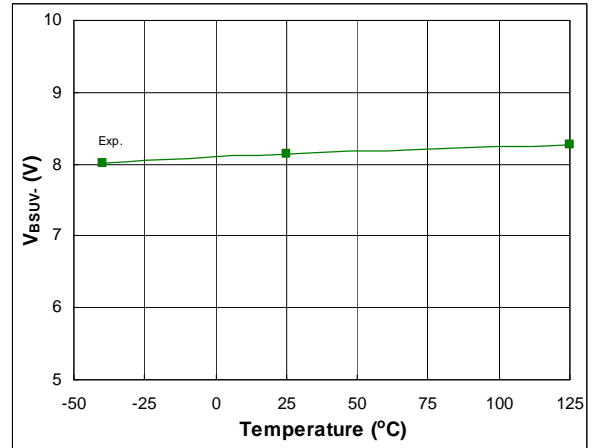

Figure 57: V_{BSUV-} vs. temperature

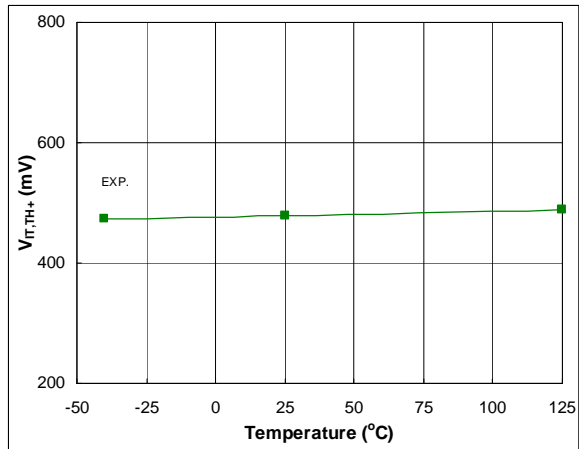

Figure 58: V_{IT,TH+} vs. temperature

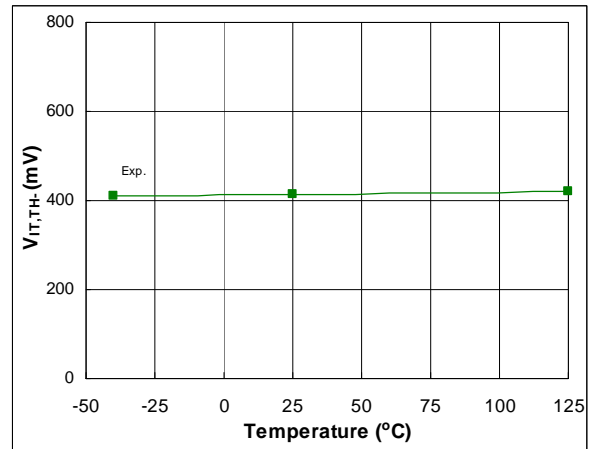

Figure 59: V_{IT,TH-} vs. temperature

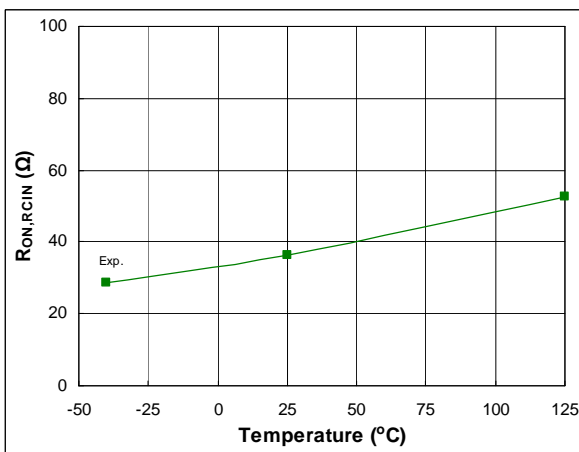

Figure 60: R_{ON,RCIN} vs. temperature

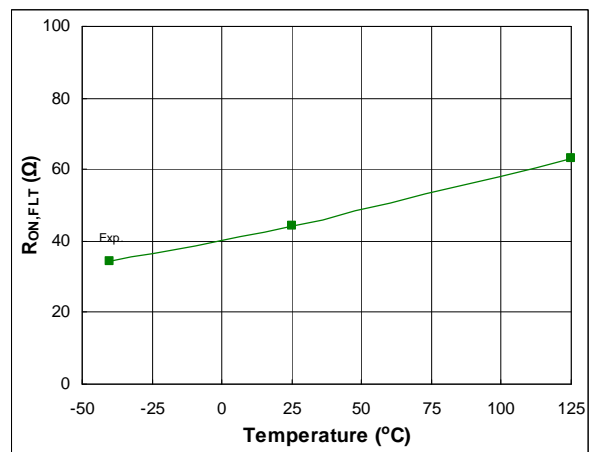
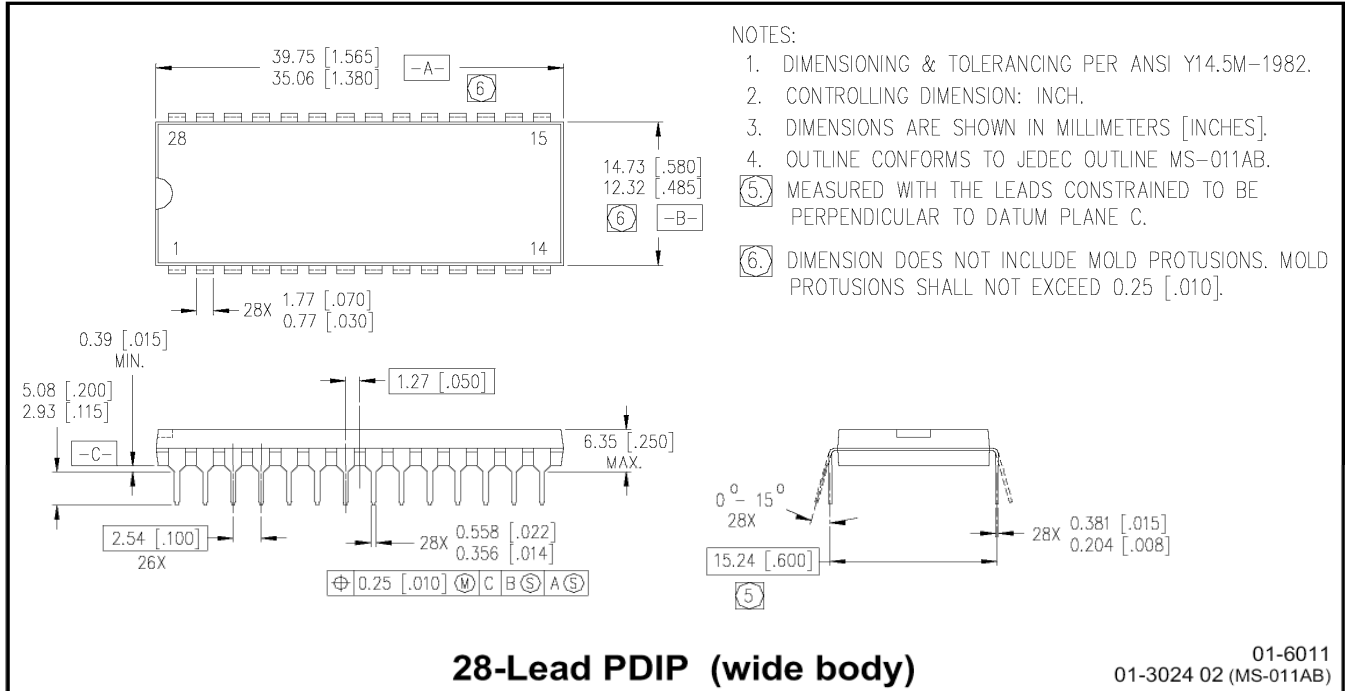

Figure 61: R_{ON,FLT} vs. temperature

Package Details: PDIP28



NOTES:

1. DIMENSIONING & TOLERANCING PER ANSI Y14.5M-1982.
2. CONTROLLING DIMENSION: INCH.
3. DIMENSIONS ARE SHOWN IN MILLIMETERS [INCHES].
4. OUTLINE CONFORMS TO JEDEC OUTLINE MS-011AB.
5. MEASURED WITH THE LEADS CONSTRAINED TO BE PERPENDICULAR TO DATUM PLANE C.
6. DIMENSION DOES NOT INCLUDE MOLD PROTUSIONS. MOLD PROTUSIONS SHALL NOT EXCEED 0.25 [.010].

Package Details: SOIC28W

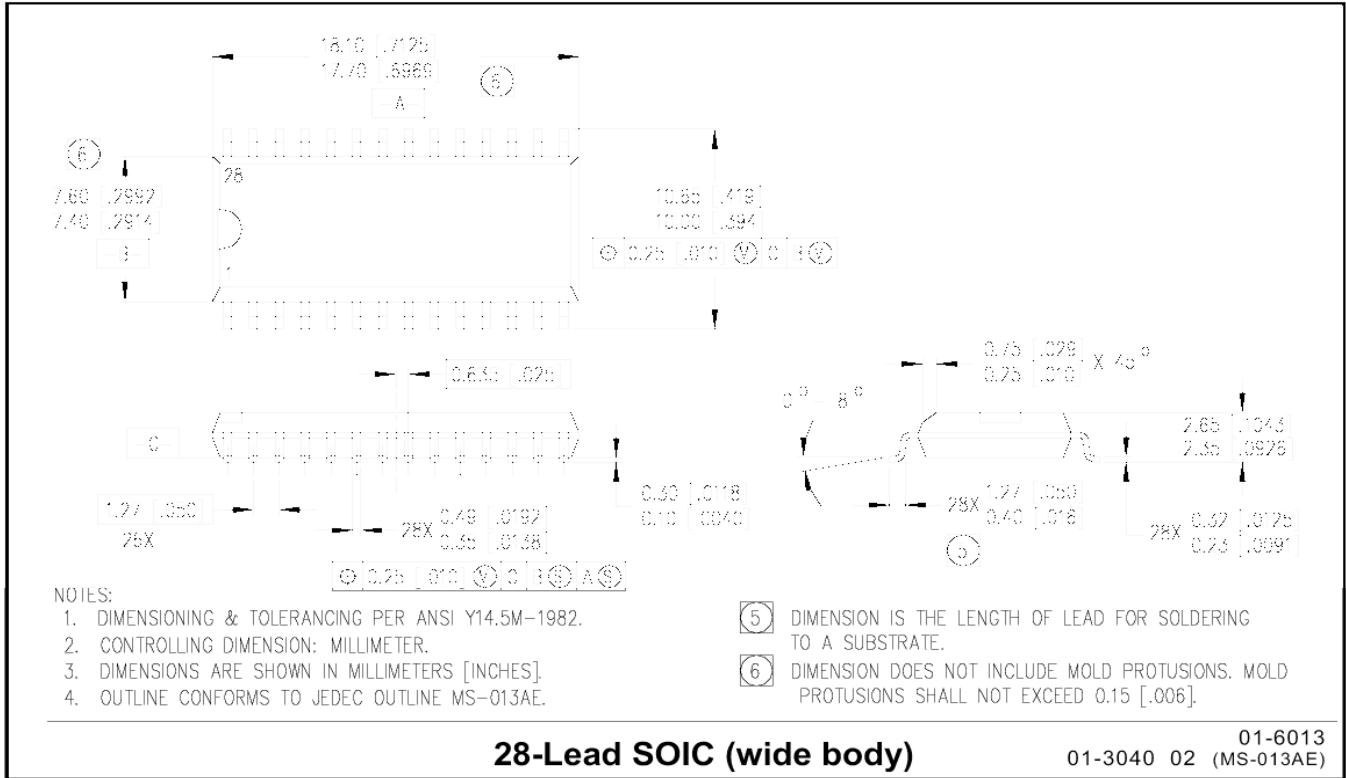

Package Details: PLCC44

QV	VN	VAX	INCH	S
F	17.40	17.65	.685	.695
C	17.40	17.65	.685	.695
H	4.20	4.57	.165	.180
W	2.28	3.04	.090	.120
K	0.14	0.48	.014	.018
L	1.77	BSC	.070	BSC
V	0.66	0.81	.026	.032
N	0.51	—	.020	—
P	0.64	—	.025	—
R	16.51	16.66	.650	.656
S	16.51	16.66	.650	.656
T	1.07	1.21	.042	.048
V	—	0.50	—	.020
W	5.08	BSC	.200	BSC
L1	15.50	16.00	.610	.630
P1	1.53	—	.060	—

NOTES

- DIMENSIONING & TOLERANCING PER ANSI Y14.5M-1982.
- DIMENSIONS SHOWN IN MILLIMETERS [INCHES].
- CONTROLLING DIMENSION: INCH.
- CONFORMS TO JEDEC OUTLINE MS-018AC.
- DATUMS -A-, -B-, -C-, & -D- ARE DETERMINED BY WHERE THE TOP OF THE LEADS EXIT PLASTIC BODY AT MOLD PARTING LINE.

6 TO BE MEASURED AT -E- SEATING PLANE.

7 DIMENSIONS DO NOT INCLUDE MOLD FLASH, ALLOWABLE FLASH IS 0.254 [.010].

44-Lead PLCC w/o 12 leads

01-6009 00
01-3004 02(mod.) (MS-018AC)

Case outline drawing for: MLPQ7X7

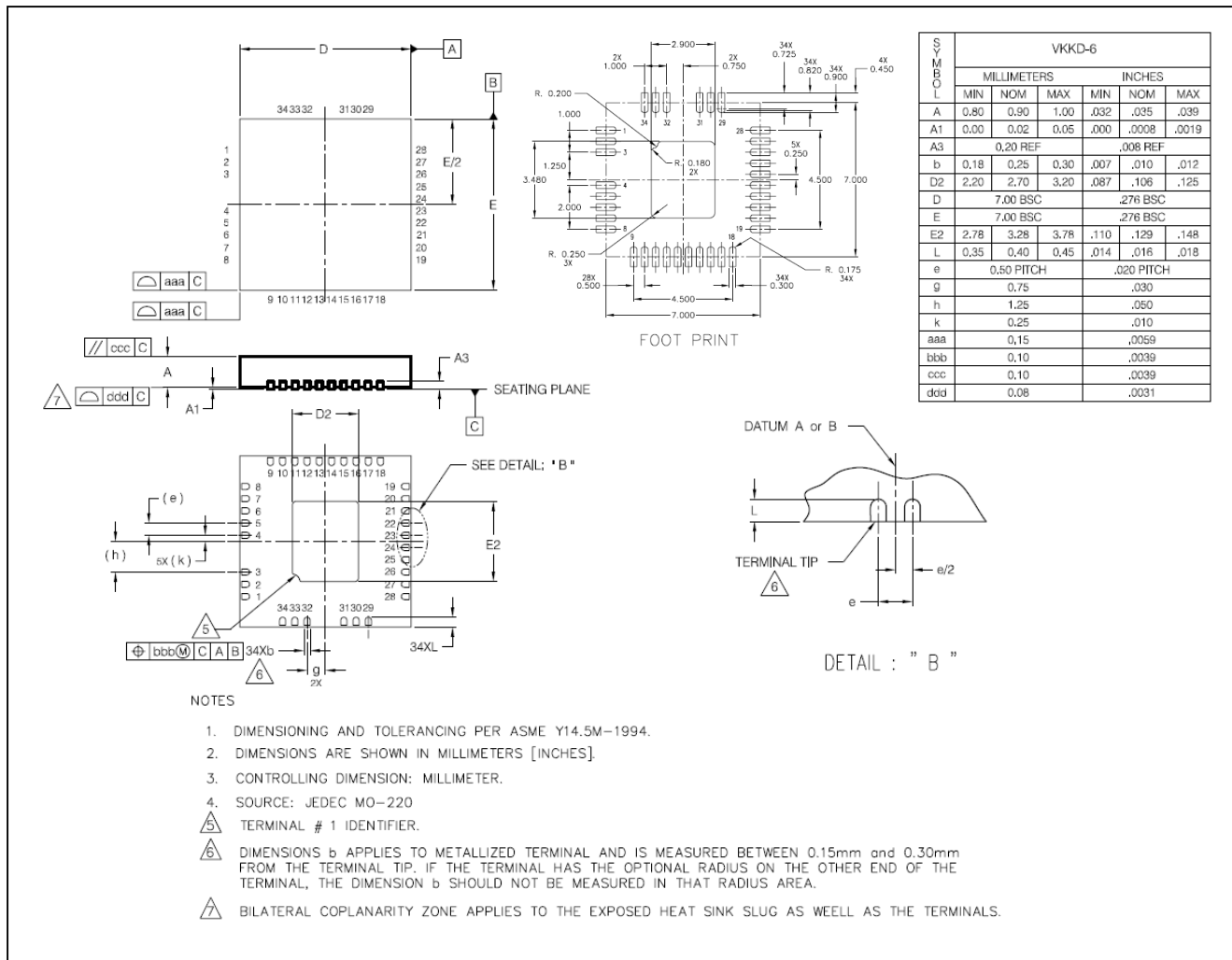

Tape and Reel Details: SOIC28W

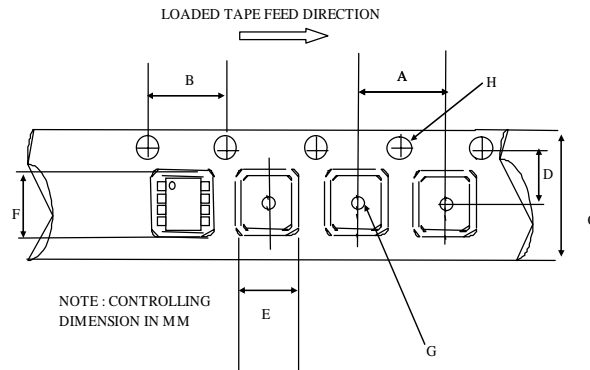

CARRIER TAPE DIMENSION FOR 28SOICW

Code	Metric		Imperial	
	Min	Max	Min	Max
A	11.90	12.10	0.468	0.476
B	3.90	4.10	0.153	0.161
C	23.70	24.30	0.933	0.956
D	11.40	11.60	0.448	0.456
E	10.80	11.00	0.425	0.433
F	18.20	18.40	0.716	0.724
G	1.50	n/a	0.059	n/a
H	1.50	1.60	0.059	0.062

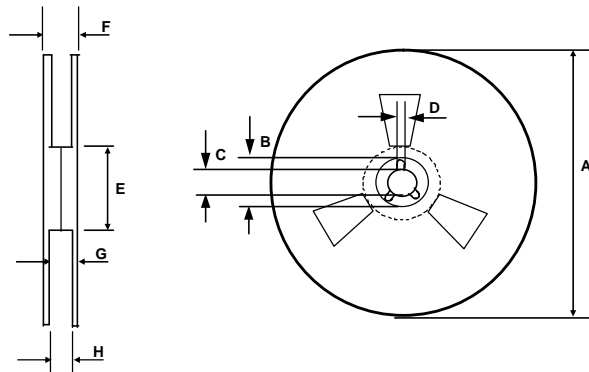

REEL DIMENSIONS FOR 28SOICW

Code	Metric		Imperial	
	Min	Max	Min	Max
A	329.60	330.25	12.976	13.001
B	20.95	21.45	0.824	0.844
C	12.80	13.20	0.503	0.519
D	1.95	2.45	0.767	0.096
E	98.00	102.00	3.858	4.015
F	n/a	30.40	n/a	1.196
G	26.50	29.10	1.04	1.145
H	24.40	26.40	0.96	1.039

Tape and Reel Details: PLCC44

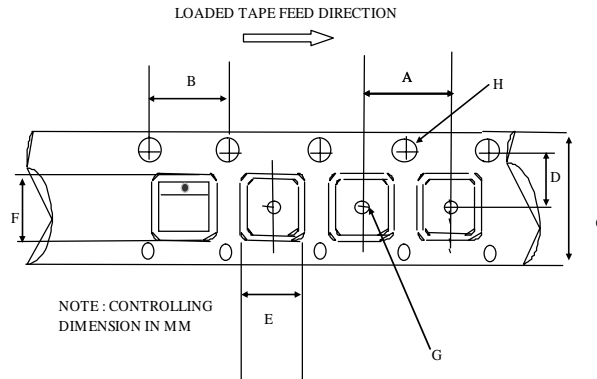

CARRIER TAPE DIMENSION FOR 44PLCC

Code	Metric		Imperial	
	Min	Max	Min	Max
A	23.90	24.10	0.94	0.948
B	3.90	4.10	0.153	0.161
C	31.70	32.30	1.248	1.271
D	14.10	14.30	0.555	0.562
E	17.90	18.10	0.704	0.712
F	17.90	18.10	0.704	0.712
G	2.00	n/a	0.078	n/a
H	1.50	1.60	0.059	0.062

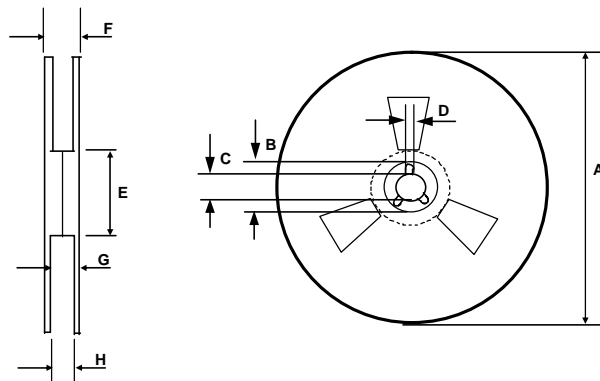

REEL DIMENSIONS FOR 44PLCC

Code	Metric		Imperial	
	Min	Max	Min	Max
A	329.60	330.25	12.976	13.001
B	20.95	21.45	0.824	0.844
C	12.80	13.20	0.503	0.519
D	1.95	2.45	0.767	0.096
E	98.00	102.00	3.858	4.015
F	n/a	38.4	n/a	1.511
G	34.7	35.8	1.366	1.409
H	32.6	33.1	1.283	1.303

Tape and Reel Details: MLPQ7X7

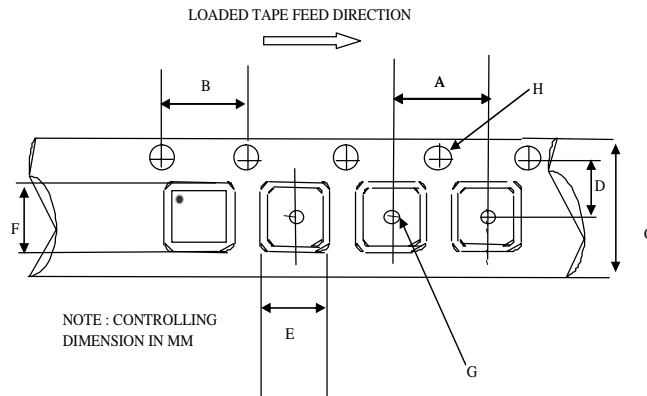

CARRIER TAPE DIMENSION FOR 48MLPQ7X7

Code	Metric		Imperial	
	Min	Max	Min	Max
A	11.90	12.10	0.474	0.476
B	3.90	4.10	0.153	0.161
C	15.70	16.30	0.618	0.641
D	7.40	7.60	0.291	0.299
E	7.15	7.35	0.281	0.289
F	7.15	7.35	0.281	0.289
G	1.50	n/a	0.059	n/a
H	1.50	1.60	0.059	0.062

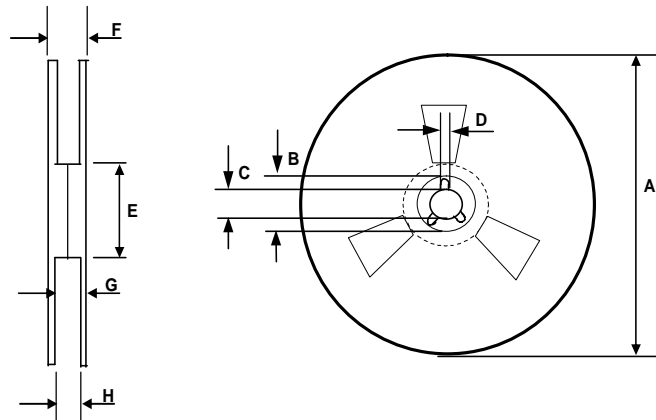

REEL DIMENSIONS FOR 48MLPQ7X7

Code	Metric		Imperial	
	Min	Max	Min	Max
A	329.60	330.25	12.976	13.001
B	20.95	21.45	0.824	0.844
C	12.80	13.20	0.503	0.519
D	1.95	2.45	0.767	0.096
E	98.00	102.00	3.858	4.015
F	n/a	22.4	n/a	0.881
G	18.5	21.1	0.728	0.83
H	16.4	18.4	0.645	0.724

Part Marking Information

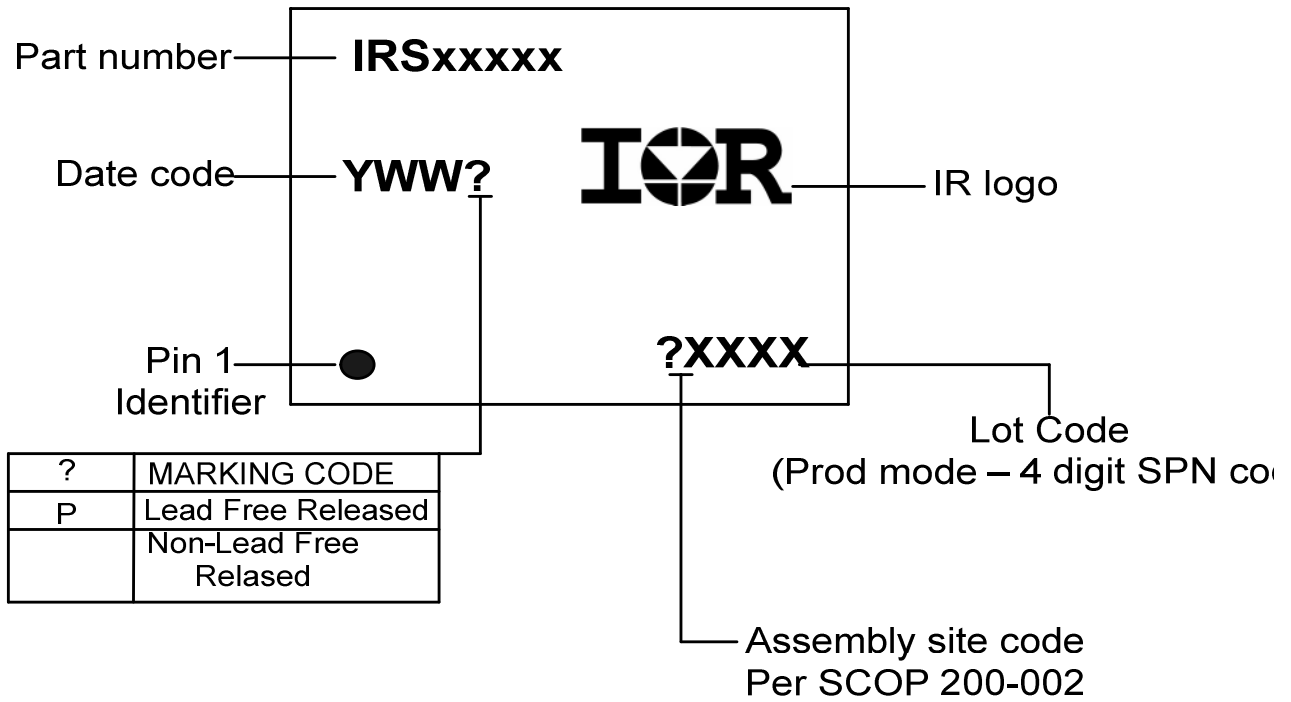

Ordering Information

Base Part Number	Package Type	Standard Pack		Complete Part Number
		Form	Quantity	
IRS2336D	MLPQ7x7 48L	Tube/Bulk	52	IRS2336DMPbF
		Tape and Reel	3000	IRS2336DMTRPbF
	PDIP28	Tube/Bulk	13	IRS2336DPbF
	SOIC28W	Tube/Bulk	25	IRS2336DSPbF
		Tape and Reel	1000	IRS2336DSTRPbF
	PLCC44	Tube/Bulk	27	IRS2336DJpBf
		Tape and Reel	500	IRS2336DJTRPbF
	IRS2336	PDIP28	Tube/Bulk	13
SOIC28W		Tube/Bulk	25	IRS2336SPbF
		Tape and Reel	1000	IRS2336STRPbF
PLCC44		Tube/Bulk	27	IRS2336JPbF
		Tape and Reel	500	IRS2336JTRPbF
IRS23364D		PDIP28	Tube/Bulk	13
	SOIC28W	Tube/Bulk	25	IRS23364DSPbF
		Tape and Reel	1000	IRS23364DSTRPbF
	PLCC44	Tube/Bulk	27	IRS23364DJpBf
		Tape and Reel	500	IRS23364DJTRPbF

The information provided in this document is believed to be accurate and reliable. However, International Rectifier assumes no responsibility for the consequences of the use of this information. International Rectifier assumes no responsibility for any infringement of patents or of other rights of third parties which may result from the use of this information. No license is granted by implication or otherwise under any patent or patent rights of International Rectifier. The specifications mentioned in this document are subject to change without notice. This document supersedes and replaces all information previously supplied.

For technical support, please contact IR's Technical Assistance Center
<http://www.irf.com/technical-info/>

WORLD HEADQUARTERS:
 233 Kansas St., El Segundo, California 90245
 Tel: (310) 252-7105

Revision History

Date	Comment
09/17/07	Original document.
01/15/08	Typo correction
01/31/08	Added MLPQ7x7 package style
02/26/08	Corrected ESD & Latch-up Classification, added note for CDM classification, added ordering information for MLPQ7x7
4/24/08	Added non-D version (not done)
5/7/08	Added non-D version in Ordering information (p47)
5/9/08	Reviewed and updated all specifications in accordance with DR3 limits tables.
16/10/09	Pag 17: IRS2336DMPbF pin assignment changed Pag 42: IRS2336DMPbF package drawing changed
26/04/11	Updated ESD HBM
27/04/2012	Add note in the lead assignment section for IRS2336DM

Looking for pricing, stock, or lifecycle information?

Click below to explore more details on WIN SOURCE:

 [View IRS2336JPBF on WIN SOURCE](#)

 [Infineon Technologies](#) Information

Optimize Your Supply Chain with WIN SOURCE Solutions

-  Global Sourcing Solution
-  Obsolete Management
-  Cost Control Management
-  Shortage Management
-  Alternative Solution
-  Excess Inventory Management