



**THE DATASHEET OF
CC12H3A-TR**



CC12H

High I²t Chip fuses

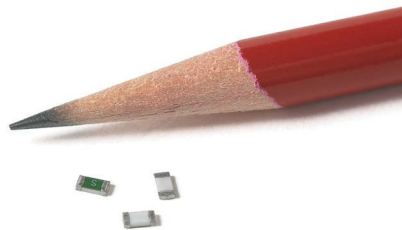

Product features

- High I²t
- High inrush withstand capability
- AEC-Q200 qualified: (750 mA to 30 A)
- Excellent temperature and cycling characteristics
- 1206 (3216 metric) compact design utilizes less board space
- Compatible with solder reflow and wave solder

Applications

Secondary circuit protection

- Laptop, notebook, netbook
- Tablets, e-readers
- Flat panel displays
- High definition television (HDTV)
- LCD/LED backlighting
- Computers and peripherals
- Gaming console systems
- Handheld/portable equipment
- Mobile device chargers

Automotive

- Central body control module
- Heating ventilation and air conditioning controllers (HVAC)
- Doors, window lift and seat control
- Digital instrument cluster
- In-vehicle infotainment (IVI) and navigation
- Electric pumps, motor control and auxiliaries
- Powertrain control module (PCU)/Engine Control unit (ECU)
- Transmission Control Unit (TCU)

Agency information

- cURus Recognition: File E19180, Guide JDYX2/JDYX8
- AEC-Q200 qualified (750 mA to 30 A)

Ordering

- Use ordering number (see page 6 for details)

Packaging suffixes

- -TR (3000 parts per 7" diameter reel, tape width 8 mm)

Electrical characteristics

Amp Rating	% of Amp Rating	Opening Time
250 mA – 30 A	100%	4 hours minimum
1 A – 3 A	200%	1.0 s – 60 s
25 A – 30 A	200%	120 s max
1 A – 5 A	250%	5.0 s max
1 A – 5 A	300%	0.1 s – 3.0 s
250 mA – 750 mA	350%	5 s max
6 A – 20 A	350%	5 s max
250 mA – 500 mA	1000%	0.01 ms – 1.0 ms
750 mA – 30 A	1000%	0.2 ms – 20 ms

Product specifications

Part Number	Current rating (A)	Voltage rating (V _{DC})	Interrupting rating ¹ (A)	Typical DC cold resistance ² (mΩ)	Typical pre-arcing ³ I ² t (A ² s)	Typical voltage drop (mV)	Part marking
CC12H250mA	0.25	63	50	3500	0.00038	1400	.25
CC12H375mA	0.375	63	50	1750	0.00077	730	A
CC12H500mA	0.5	63	50	980	0.0019	700	.5
CC12H750mA	0.75	63	50	800	0.15	700	E
CC12H1A	1	63	50	470	0.18	490	H
CC12H1.5A	1.5	63	50	218	0.4	355	K
CC12H2A	2	63	50	133	1.1	305	N
CC12H2.5A	2.5	63	50	79	1.7	240	O
CC12H3A	3	63	50	49	2.2	185	P
CC12H3.5A	3.5	63	50	37	2.7	180	R
CC12H4A	4	63	50	33	3.2	169	S
CC12H4.5A	4.5	32	100	28	4.2	160	X
CC12H5A	5	32	100	23	6	140	T
CC12H6A	6	32	100	15.5	12	150	F
CC12H7A	7	32	100	11.5	18	130	J
CC12H8A	8	32	100	7.3	18	110	V
CC12H10A	10	32	100	6.5	30	90	U
CC12H12A	12	32	100	4.7	45	90	W
CC12H15A	15	32	100	3	33	90	Y
CC12H20A	20	32	100	2	80	90	Q
CC12H25A	25	32	200	3	60	90	L
CC12H30A	30	32	200	2.1	100	90	Z

1. DC interrupting rating measured at rated voltage, time constant of less than 50 microseconds, battery source.
2. Typical DC cold resistance measured at <10% of rated current.
3. Typical pre-arcing I²t value is measured at 10I_n rated current.

Dimensions—mm

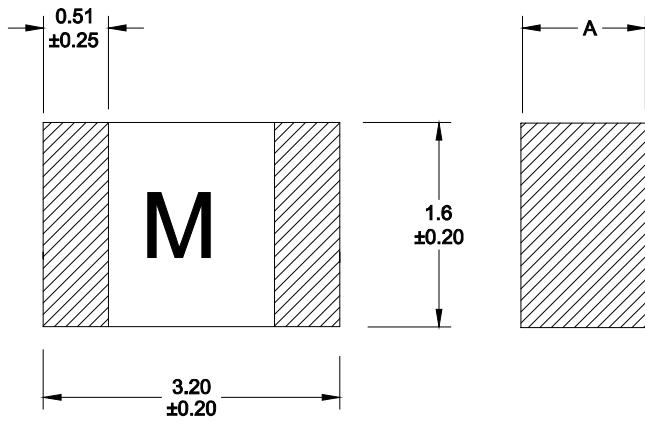

Recommended Pad Layout

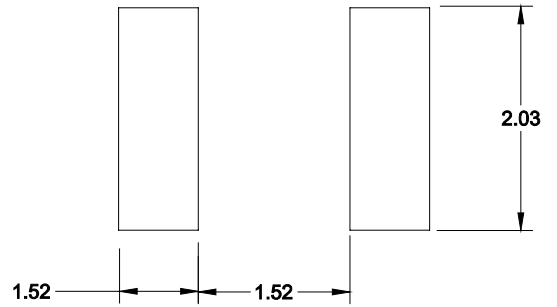

Dimension A	
250 mA to 500 mA	750 mA to 30 A
0.89 +0.20/-0.15	0.65 +0.20/-0.15

Packaging information- mm

Supplied in tape and reel packaging, 3000 parts per 7" diameter reel.

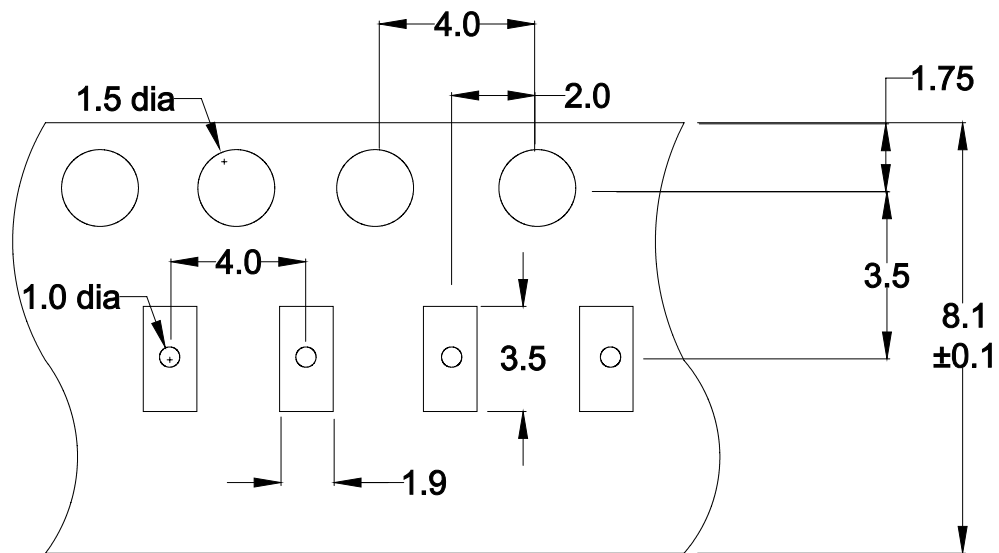

User Direction of Feed →

I²t vs. time curve

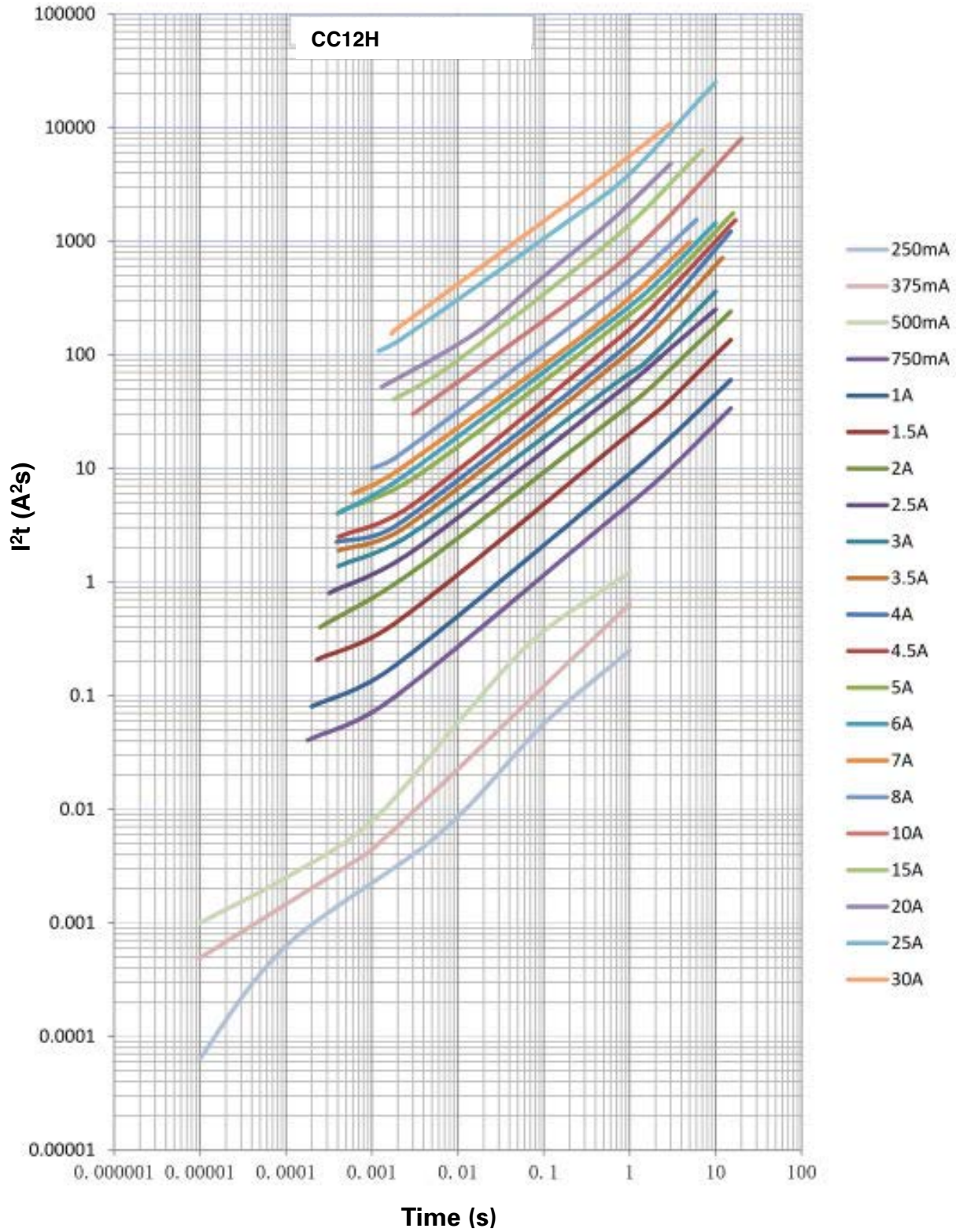

Time vs. current curve

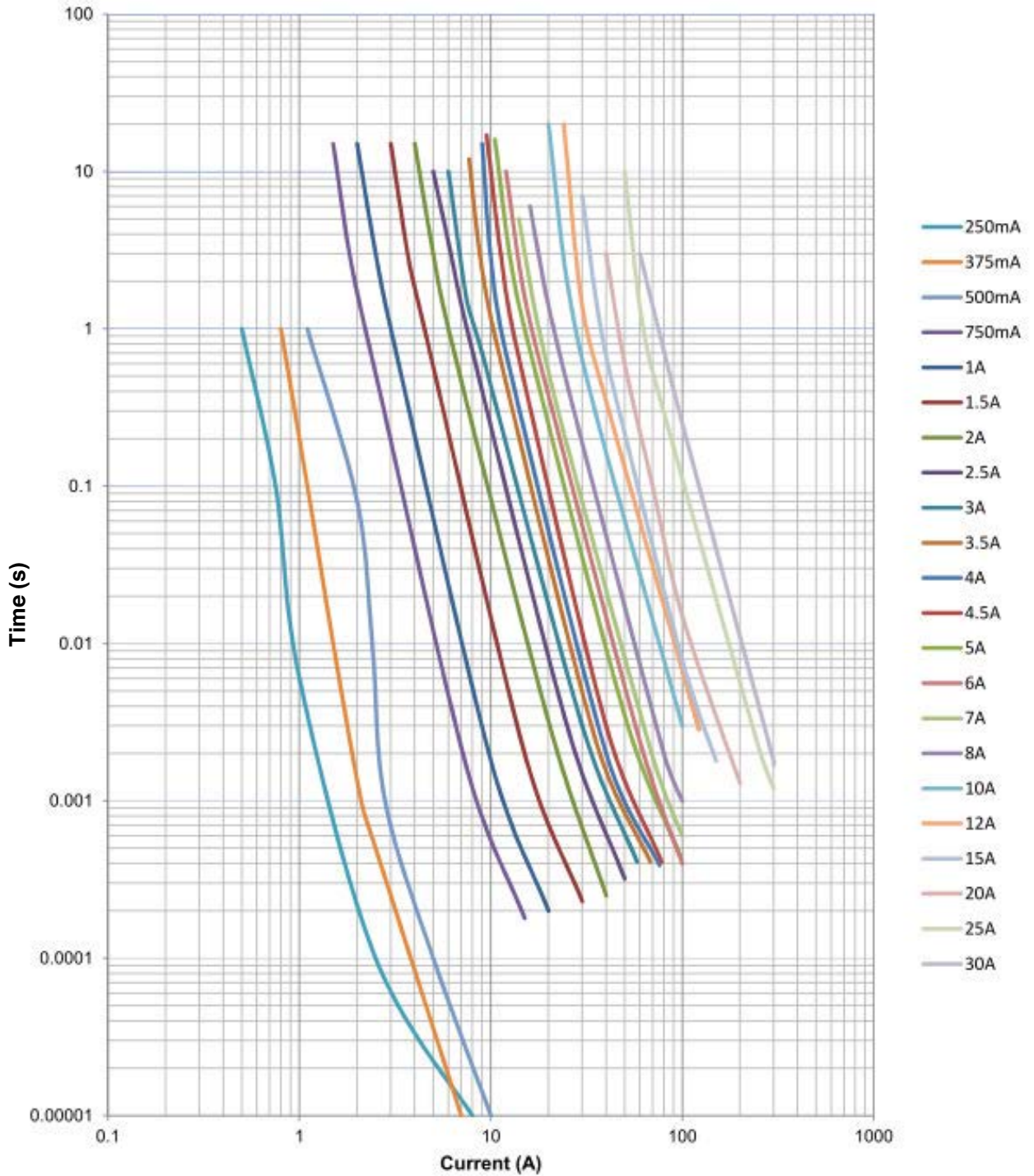

Temperature derating curve

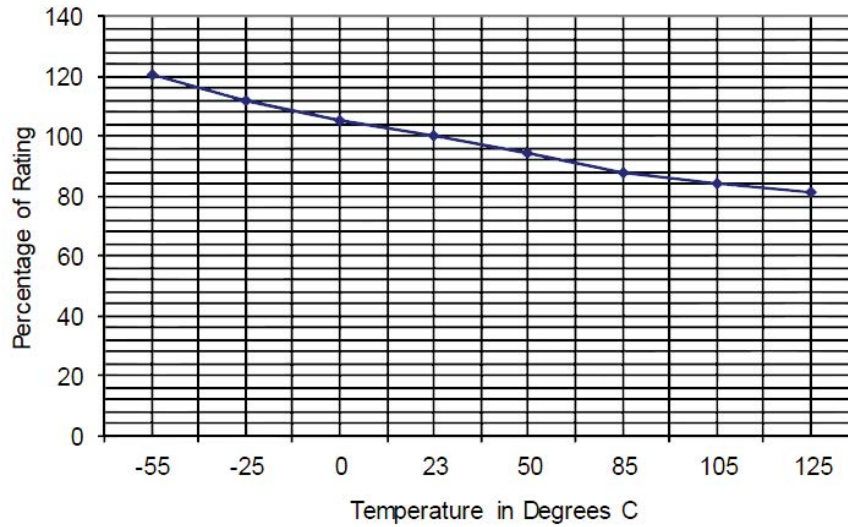

Environmental data

Operating temperature: -55 °C to +125 °C (with derating); (20 A- 30 A) -40 °C to +85 °C (with derating)

Thermal shock: MIL- STD- 202G, Method 107, (300 cycles -55 °C to +125 °C)

Vibration: MIL-STD- 202G, Method 204, (20 g's for 20 minutes, 12 cycles in each of 3 orientations, 10- 2000 Hz)

Humidity: MIL- STD- 202G, Method 103, (+85 °C, 85% relative humidity, 1000 hours 10% of operating power)

Mechanical shock: MIL-STD- 202G, Method 213, Condition C

Ordering codes

The ordering code is the part number replacing the “.” with a “-” plus adding the packaging suffix.

Packaging suffix

- -TR (3000 parts on a 7” reel, tape width 8 mm).

Part Number	Ordering code
	-TR option
CC12H250mA	CC12H250mA-TR
CC12H375mA	CC12H375mA-TR
CC12H500mA	CC12H500mA-TR
CC12H750mA	CC12H750mA-TR
CC12H1A	CC12H1A-TR
CC12H1.5A	CC12H1-5A-TR
CC12H2A	CC12H2A-TR
CC12H2.5A	CC12H2-5A-TR
CC12H3A	CC12H3A-TR
CC12H3.5A	CC12H3-5A-TR

Part Number	Ordering code
	-TR option
CC12H4A	CC12H4A-TR
CC12H4.5A	CC12H4-5A-TR
CC12H5A	CC12H5A-TR
CC12H6A	CC12H6A-TR
CC12H7A	CC12H7A-TR
CC12H8A	CC12H8A-TR
CC12H10A	CC12H10A-TR
CC12H12A	CC12H12A-TR
CC12H15A	CC12H15A-TR
CC12H20A	CC12H20A-TR
CC12H25A	CC12H25A-TR
CC12H30A	CC12H30A-TR

Wave solder profile

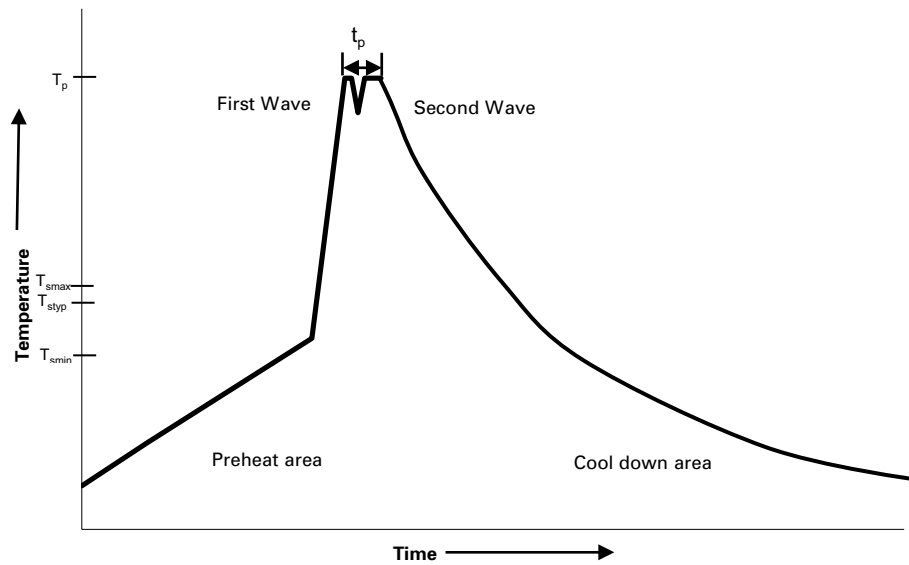

Reference EN 61760-1:2006

Profile Feature	Standard SnPb Solder	Lead (Pb) Free Solder
Preheat	• Temperature min. (T_{smin})	100°C
	• Temperature typ. (T_{styp})	120°C
	• Temperature max. (T_{smax})	130°C
	• Time (T_{smin} to T_{smax}) (t_s)	70 seconds
Δ preheat to max Temperature	150°C max.	150°C max.
Peak temperature (T_p)*	235°C – 260°C	250°C – 260°C
Time at peak temperature (t_p)	10 seconds max 5 seconds max each wave	10 seconds max 5 seconds max each wave
Ramp-down rate	~ 2 K/s min ~3.5 K/s typ ~5 K/s max	~ 2 K/s min ~3.5 K/s typ ~5 K/s max
Time 25°C to 25°C	4 minutes	4 minutes

Manual solder

350°C, 4-5 seconds. (by soldering iron), generally manual, hand soldering is not recommended.

Solder reflow profile

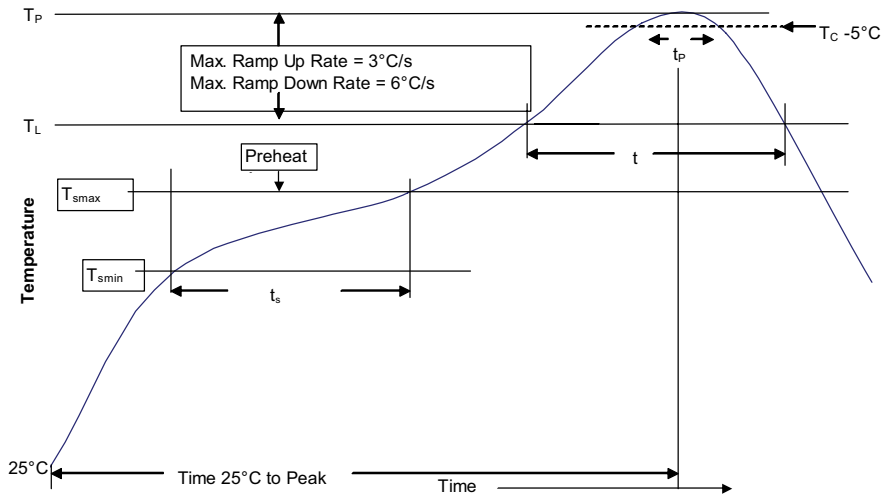

Table 1 - Standard SnPb Solder (T_C)

Package Thickness	Volume mm ³ <350	Volume mm ³ ≥350
<2.5mm)	235°C	220°C
≥2.5mm	220°C	220°C

Table 2 - Lead (Pb) Free Solder (T_C)

Package Thickness	Volume mm ³ <350	Volume mm ³ 350 - 2000	Volume mm ³ >2000
<1.6mm	260°C	260°C	260°C
1.6 – 2.5mm	260°C	250°C	245°C
>2.5mm	250°C	245°C	245°C

Reference JDEC J-STD-020

Profile Feature	Standard SnPb Solder	Lead (Pb) Free Solder
Preheat and Soak	<ul style="list-style-type: none"> Temperature min. (T_{smin}) Temperature max. (T_{smax}) Time (T_{smin} to T_{smax}) (t_s) 	<ul style="list-style-type: none"> 100°C 150°C 60-120 Seconds
Average ramp up rate T _{smax} to T _p	3°C/ Second Max.	3°C/ Second Max.
Liquidous temperature (T _L) Time at liquidous (t _L)	183°C 60-150 Seconds	217°C 60-150 Seconds
Peak package body temperature (T _p)*	Table 1	Table 2
Time (t _p)** within 5 °C of the specified classification temperature (T _C)	20 Seconds**	30 Seconds**
Average ramp-down rate (T _p to T _{smax})	6°C/ Second Max.	6°C/ Second Max.
Time 25°C to Peak Temperature	6 Minutes Max.	8 Minutes Max.

* Tolerance for peak profile temperature (T_p) is defined as a supplier minimum and a user maximum.

** Tolerance for time at peak profile temperature (t_p) is defined as a supplier minimum and a user maximum.

Life Support Policy: Eaton does not authorize the use of any of its products for use in life support devices or systems without the express written approval of an officer of the Company. Life support systems are devices which support or sustain life, and whose failure to perform, when properly used in accordance with instructions for use provided in the labeling, can be reasonably expected to result in significant injury to the user.

Eaton reserves the right, without notice, to change design or construction of any products and to discontinue or limit distribution of any products. Eaton also reserves the right to change or update, without notice, any technical information contained in this bulletin.

Eaton
Electronics Division
1000 Eaton Boulevard
Cleveland, OH 44122
United States
www.eaton.com/electronics

© 2017 Eaton
All Rights Reserved
Printed in USA
Publication No. 4309 BU-MC16040
November 2017

Eaton is a registered trademark.

All other trademarks are property of their respective owners.

Looking for pricing, stock, or lifecycle information?

Click below to explore more details on WIN SOURCE:

 [View CC12H3A-TR on WIN SOURCE](#)

 [Eaton Bussmann Information](#)

Optimize Your Supply Chain with WIN SOURCE Solutions

-  Global Sourcing Solution
-  Obsolete Management
-  Cost Control Management
-  Shortage Management
-  Alternative Solution
-  Excess Inventory Management