



**THE DATASHEET OF
IPS7091GPBF**



IPS7091(G)(S)PbF

INTELLIGENT POWER HIGH SIDE SWITCH

Features

- Over temperature shutdown (with auto-restart)
- Short circuit protection (current limit)
- Active clamp
- Open load detection
- Logic ground isolated from power ground
- ESD protection
- Ground loss protection
- Status feedback

Product Summary

Rds(on)	120mΩ max.
Vclamp	70V
I Limit	5A (typ.)
Open load	3V

Description

The IPS7091(G)(S)PbF is a five terminal Intelligent Power Switch (IPS) with built in short circuit, over-temperature, ESD protection, inductive load capability and diagnostic feedback. The output current is limited at Ilim value. Current limitation is activated until the thermal protection acts. The over-temperature protection turns off the device if the junction temperature exceeds Tshutdown. It will automatically restart after the junction has cooled 7°C below Tshutdown. A diagnostic pin is provided for status feedback of short circuit, over-temperature and open load detection. The double level shifter circuitry allows large offsets between the logic ground and the load.

Package

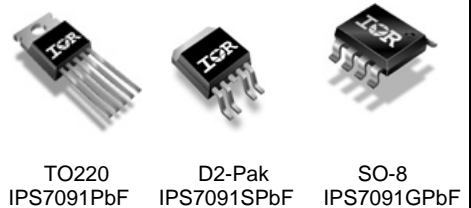

Typical Connection

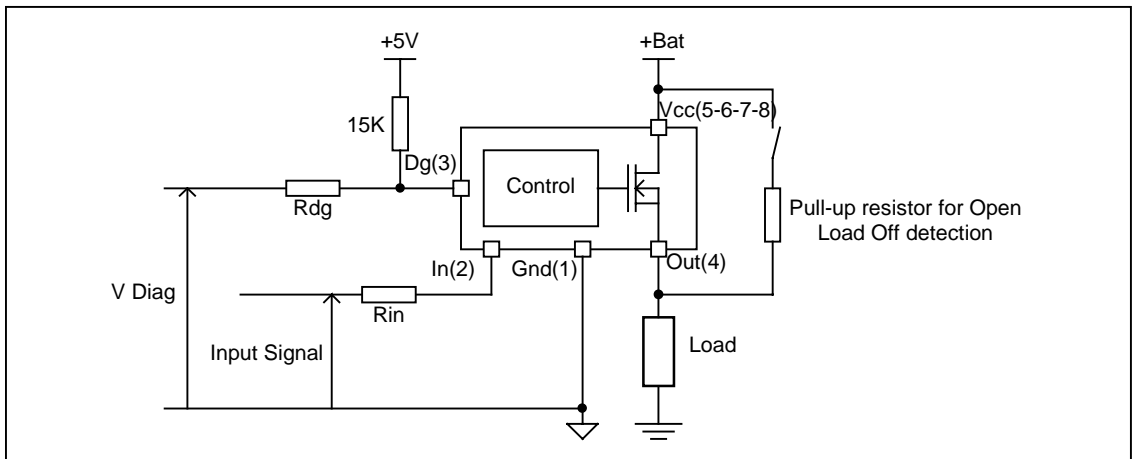

Absolute Maximum Ratings

Absolute maximum ratings indicate sustained limits beyond which damage to the device may occur. All voltage parameters are referenced to Ground lead. (Tambient=25°C unless otherwise specified).

Symbol	Parameter	Min.	Max.	Units
Vout	Maximum output voltage	Vcc-65	Vcc+0.3	V
Voffset	Maximum logic ground to load ground offset	Vcc-65	Vcc+0.3	
Vin	Maximum input voltage	-0.3	5.5	
Vcc max.	Maximum Vcc voltage	—	65	
Vcc cont.	Maximum continuous Vcc voltage	—	35	
Iin max.	Maximum IN current	-1	10	mA
I _{dg} max.	Maximum diagnostic output current	-1	10	
V _{dg}	Maximum diagnostic output voltage	-0.3	5.5	V
P _d	Maximum power dissipation (internally limited by thermal protection) R _{th} =100°C/W	—	1.25	W
I _{sd} cont.	Maximum continuous diode current (R _{th} =100°C/W)	—	1.8	A
ESD1	Electrostatic discharge voltage (Human body) 100pF, 1500Ω	—	4	kV
ESD2	Electrostatic discharge voltage (Machine Model) C=200pF, R=0Ω, L=10μH	—	0.5	
T _j max.	Max. storage & operating temperature junction temperature	-40	+150	°C

Thermal Characteristics

Symbol	Parameter	Typ.	Max.	Units
R _{th1}	Thermal resistance junction to ambient SO8 std. footprint	100	—	°C/W
R _{th1}	Thermal resistance junction to ambient TO220 free air	60	—	
R _{th1}	Thermal resistance junction to ambient D2Pak std. footprint	60	—	
R _{th2}	Thermal resistance junction to ambient D2Pak 1" sqrt. footprint	40	—	
R _{th3}	Thermal resistance junction to case D2pak/TO220	4	—	

Recommended Operating Conditions

These values are given for a quick design. For operation outside these conditions, please consult the application notes.

Symbol	Parameter	Min.	Max.	Units
V _{IH}	High level input voltage	4	5.5	
V _{IL}	Low level input voltage	-0.3	0.9	
I _{out}	Continuous drain current, Tamb=85°C, Tj=125°C, Vin=5V, Rth=100°C/W	—	1.5	A
R _{in}	Recommended resistor in series with IN pin	10	20	kΩ
R _{dg}	Recommended resistor in series with DG pin	10	20	
R _{ol}	Recommended pull-up resistor for open load detection	5	100	

Static Electrical Characteristics

T_J=25°C, V_{CC}=14V (unless otherwise specified)

Symbol	Parameter	Min.	Typ.	Max.	Units	Test Conditions
R _{ds(on)}	ON state resistance T _J =25°C	—	80	120	mΩ	V _{in} =5V, I _{out} =2A
	ON state resistance T _J =150°C	—	150	230		V _{in} =5V, I _{out} =2A
	ON state resistance T _J =25°C, V _{CC} =6.5V	—	90	130		V _{in} =5V, I _{out} =2A
V _{CC op.}	Operating voltage range	6	—	35	V	
V clamp 1	V _{CC} to Out clamp voltage 1	65	70	—		I _{out} =30mA (see Fig. 1)
V clamp 2	V _{CC} to Out clamp voltage 2	—	70	75		I _{out} =1A (see Fig. 1)
V _f	Body diode forward voltage	—	1	1.35		I _{out} = 2.5A
I _{CC Off}	Supply current when Off	—	2.5	10	μA	V _{in} =0V, V _{out} =0V
I _{CC On}	Supply current when On	—	2.5	3.5	mA	V _{in} =5V
I _{out@0V}	Output leakage current	—	—	10	μA	V _{out} =0V
I _{out@6V}	Output leakage current	—	20	—		V _{out} =6V
I _{dg leakage}	Diagnostic output leakage current	—	—	10		V _{dg} =5.5V
V _{dgl}	Low level diagnostic output voltage	—	0.2	0.3		I _{dg} =1.6mA
V _{ih}	Input high threshold voltage	—	2.5	3.5	V	
V _{il}	Input low threshold voltage	1	2	—		
I _{n hys}	Input hysteresis	0.15	0.4	1		
UV high	Under voltage high threshold voltage	—	5	5.9		
UV low	Under voltage low threshold voltage	3.4	4.5	—		
UV hys	Undervoltage hysteresis	0.1	0.8	1.5		
I _{in On}	Input current when device is On	—	40	80	μA	V _{in} =5V

Switching Electrical Characteristics

V_{CC}=14V, Resistive load=14Ω, V_{in}=5V, T_J=25°C

Symbol	Parameter	Min.	Typ.	Max.	Units	Test Conditions
T _{don}	Turn-on delay time	—	12	35	μs	See Fig. 3
Tr1	Rise time to V _{out} =V _{CC} -5V	—	7	40		
Tr2	Rise time to V _{out} =0.9 x V _{CC}	—	14	50		
dV/dt (On)	Turn On dV/dt	—	0.95	3.5	V/μs	
E _{On}	Turn On energy	—	250	—	μJ	
T _{doff}	Turn-off delay time	—	20	45	μs	
T _f	Fall time to V _{out} =0.1 x V _{CC}	—	6	25	μs	
dV/dt (Off)	Turn Off dV/dt	—	1.8	5.5	V/μs	
E _{Off}	Turn Off energy	—	20	—	μJ	
T _{diag}	V _{out} to V _{diag} propagation delay	—	15	—	μs	See Fig. 4 and Fig. 12

Protection Characteristics

Symbol	Parameter	Min.	Typ.	Max.	Units	Test Conditions
Ilim	Internal current limit	2	5	8	A	Vout=0V
Tsd+	Over temperature high threshold	150 ⁽¹⁾	165	—	°C	See Fig. 2
Tsd-	Over temperature low threshold	—	158	—		
Vsc	Short-circuit detection voltage ⁽²⁾	2	3	4	V	
Vopen load	Open load detection threshold	2	3	4		

⁽¹⁾ Guaranteed by design

⁽²⁾ Reference to Vcc

Truth Table

Operating Conditions	IN	OUT	DG pin
Normal	H	H	H
Normal	L	L	L
Open Load	H	H	H
Open Load ⁽³⁾	L	H	H
Short circuit to Gnd	H	L (limiting)	L
Short circuit to Gnd	L	L	L
Over-temperature	H	L (cycling)	L
Over-temperature	L	L	L

⁽³⁾ With a pull-up resistor connected between the output and Vcc.

Lead Assignments

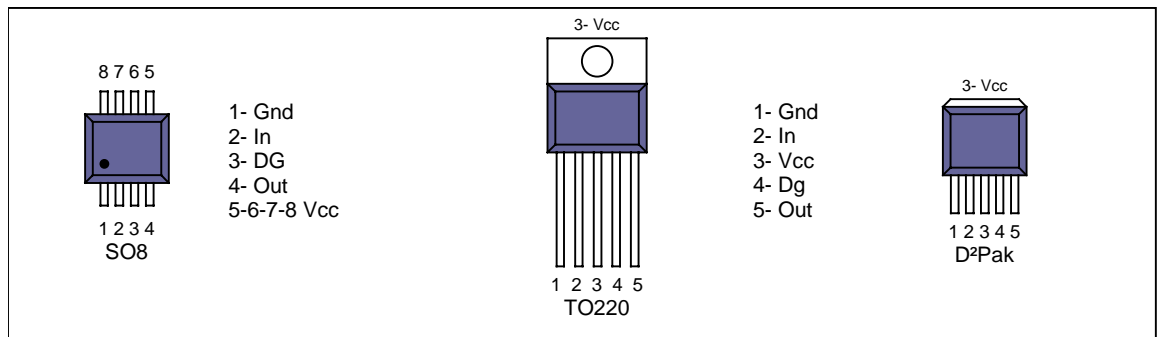

Functional Block Diagram

All values are typical

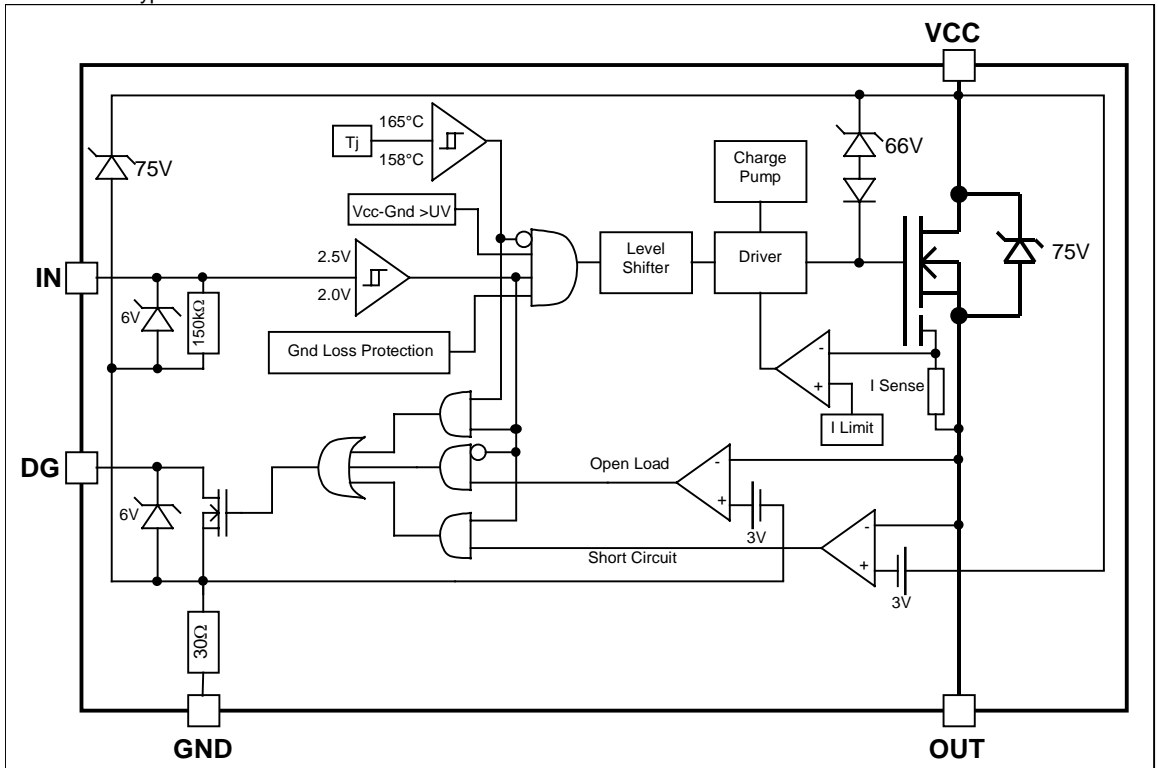

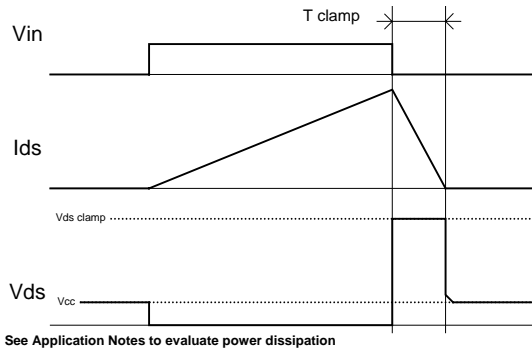

Figure 1 – Active clamp waveforms

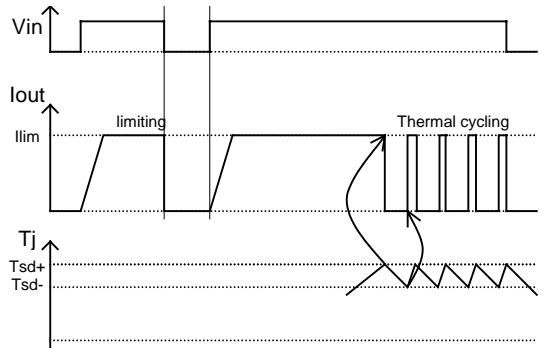

Figure 2 – Protection timing diagram

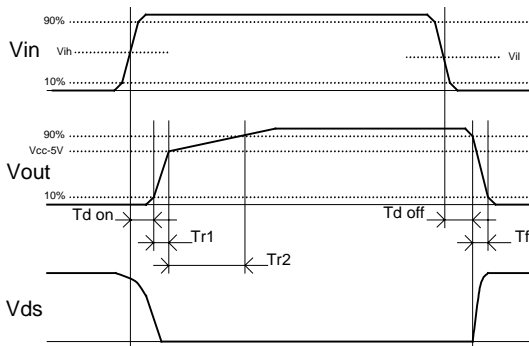

Figure 3 – Switching times definition

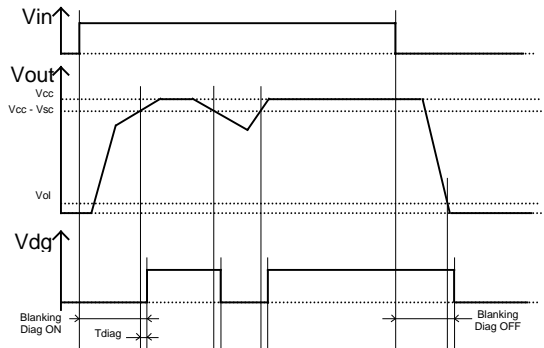

Figure 4 – Diagnostic delay definition

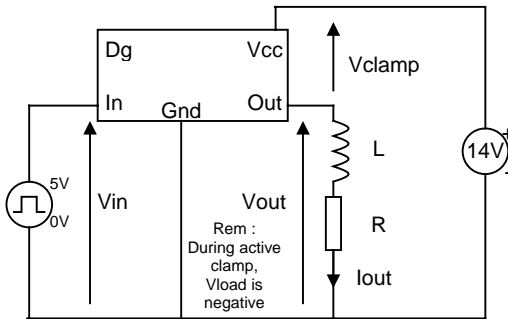

Figure 5 – Active clamp test circuit

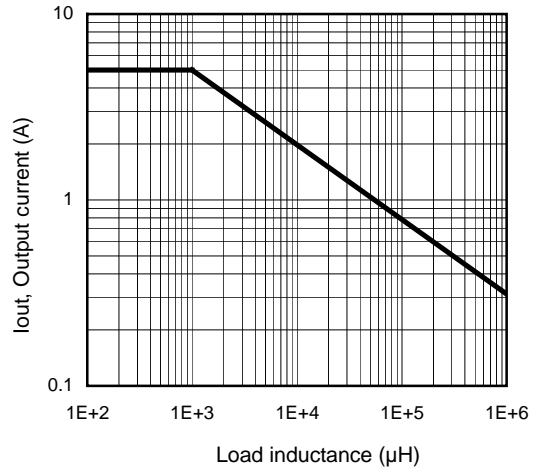

Figure 6 – Max. Output current (A) Vs Load inductance (µH)

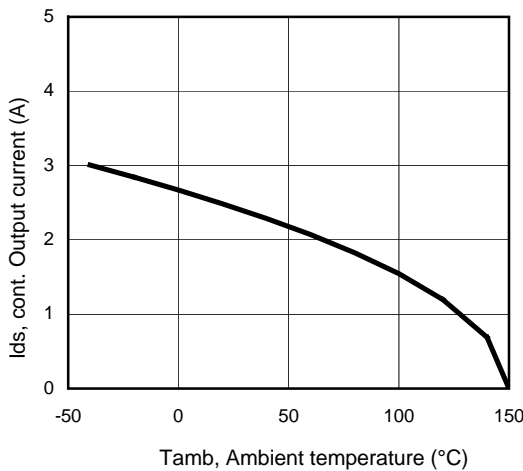

Figure 7 – Max. output current (A) Vs Ambient temperature (°C) Rth=100°C/W

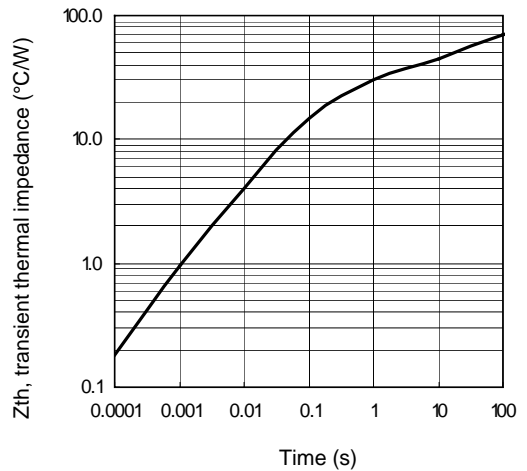
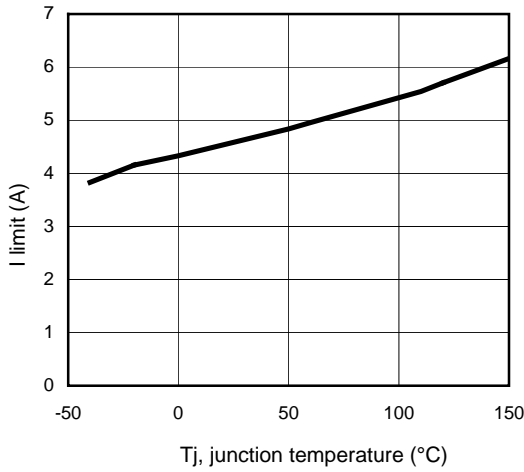
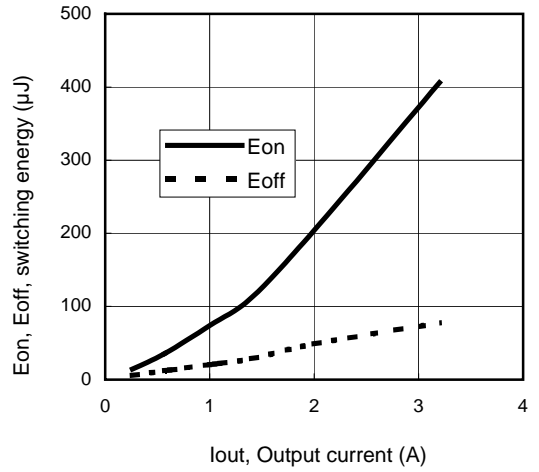

Figure 8 – Transient thermal impedance (°C/W) Vs time (s)



**Figure 9 – I limit (A)
Vs junction temperature (°C)**



**Figure 10 – Switching energy (µJ)
Vs Output current (A)**

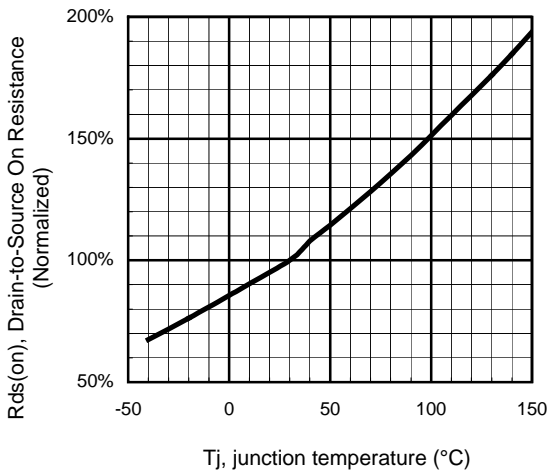
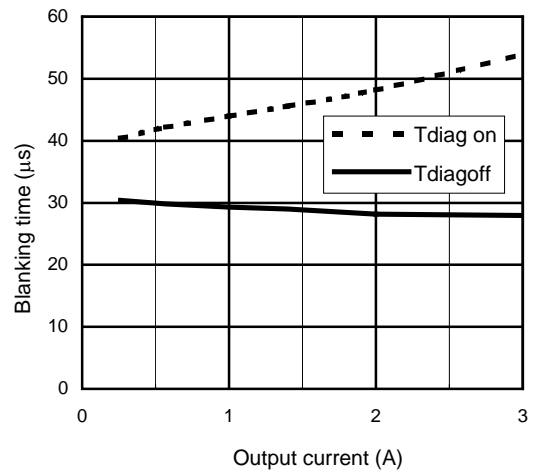

Figure 11 - Normalized R_{ds(on)} (%) Vs T_j (°C)



**Figure 12 – Diagnosis Blanking time (µs)
Vs Output current (A)**

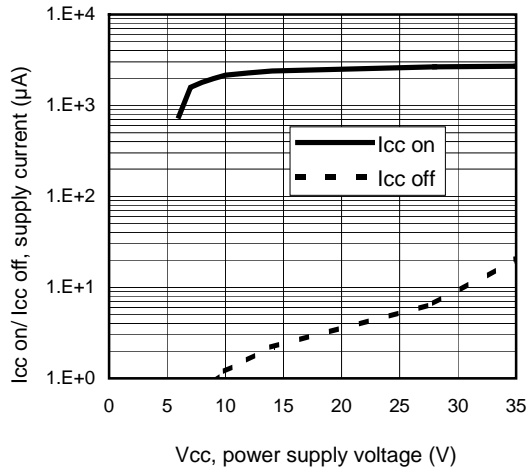

Figure 13 – I_{cc on}/ I_{cc off} (µA) Vs V_{cc} (V)

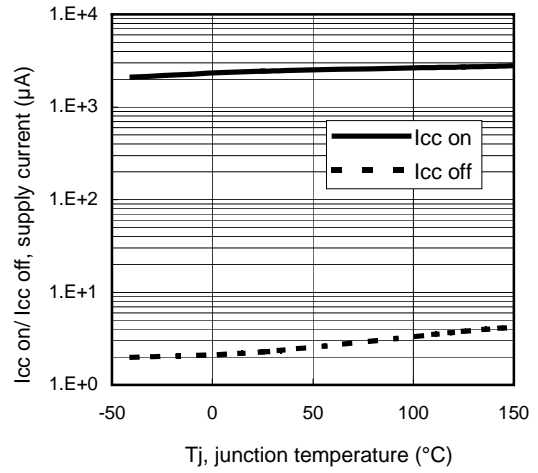
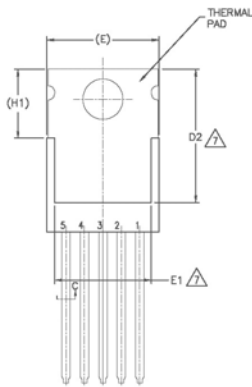
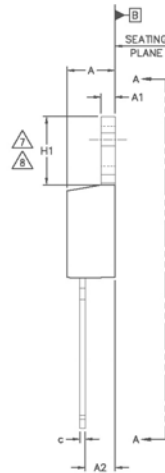
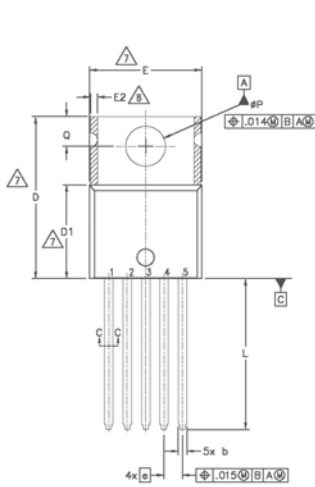
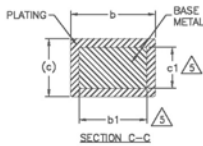

Figure 14 – I_{cc on}/ I_{cc off} (µA) Vs T_j (°C)

Case outline - TO220



SECTION A-A



SECTION C-C

DIMENSION	DIMENSIONS				UNIT
	MILLIMETERS		INCHES		
	MIN.	MAX.	MIN.	MAX.	
A	3.56	4.83	.140	.190	5
A1	0.51	1.40	.020	.055	
A2	2.03	2.92	.080	.115	
b	0.84	0.89	.025	.035	
b1	0.64	0.84	.025	.033	
c	0.36	0.61	.014	.024	5
c1	0.36	0.56	.014	.022	
D	14.22	16.51	.560	.650	4
D1	8.38	9.02	.330	.355	7
D2	11.68	12.88	.460	.507	
E	9.65	10.67	.380	.420	4,7
E1	6.86	8.89	.270	.350	7
E2	-	0.76	-	.030	8
e	1.70 BSC		.067 BSC		7,8
H1	5.84	6.86	.230	.270	
L	12.70	14.73	.500	.580	7,8
φP	3.53	3.73	.139	.147	
φQ	2.54	3.05	.100	.120	

NOTES:

- 1.- DIMENSIONING AND TOLERANCING AS PER ASME Y14.5 M- 1994.
- 2.- DIMENSIONS ARE SHOWN IN INCHES [MILLIMETERS].
- 3.- LEAD DIMENSION AND FINISH UNCONTROLLED IN L1.
- 4.- DIMENSION D, D1 & E DO NOT INCLUDE MOLD FLASH. MOLD FLASH SHALL NOT EXCEED .005" (0.127) PER SIDE. THESE DIMENSIONS ARE MEASURED AT THE OUTERMOST EXTREMES OF THE PLASTIC BODY.
- 5.- DIMENSION b1 & c1 APPLY TO BASE METAL ONLY.
- 6.- CONTROLLING DIMENSION - INCHES.
- 7.- THERMAL PAD CONTOUR OPTIONAL WITHIN DIMENSIONS E,H1,D2 & E1
- 8.- DIMENSION E2 X H1 DEFINE A ZONE WHERE STAMPING AND SINGULATION IRREGULARITIES ARE ALLOWED.
- 9.- OUTLINE CONFORMS TO JEDEC TO-220, EXCEPT A2 (max.) AND D2 (min.) WHERE DIMENSIONS ARE DERIVED FROM THE ACTUAL PACKAGE OUTLINE.
- 10.- LEADS AND DRAIN ARE PLATED WITH 100% Sn

Case outline – D²Pak

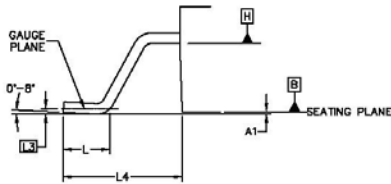

DETAIL "A"
 ROTATED 90° CW
 SCALE B:1

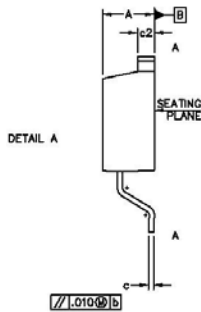
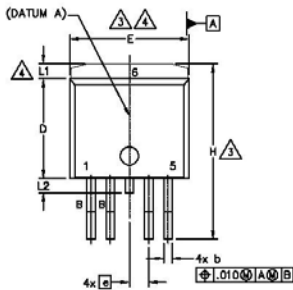
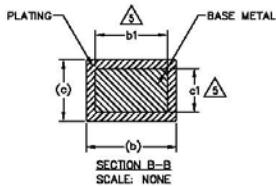
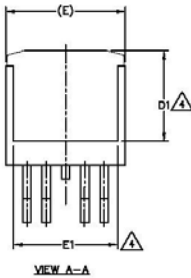

NOTES:

1. DIMENSIONING AND TOLERANCING AS PER ASME Y14.5M-1994
2. DIMENSIONS ARE SHOWN IN MILLIMETERS [INCHES].
3. DIMENSION D & E DO NOT INCLUDE MOLD FLASH. MOLD FLASH SHALL NOT EXCEED 0.127 [.005"] PER SIDE. THESE DIMENSIONS ARE MEASURED AT THE OUTMOST EXTREMES OF THE PLASTIC BODY AT DATUM H.
4. THERMAL PAD CONTOUR OPTIONAL WITHIN DIMENSION E, L1, D1 & E1.
5. DIMENSION b1 AND c1 APPLY TO BASE METAL ONLY.
6. DATUM A & B TO BE DETERMINED AT DATUM PLANE H.
7. CONTROLLING DIMENSION: INCH.
8. OUTLINE CONFORMS TO JEDEC OUTLINE TO-263BA.
9. LEADS AND DRAIN ARE PLATED : 100% Sn

SYMBOL	DIMENSIONS				NOTES
	MILLIMETERS		INCHES		
	MIN.	MAX.	MIN.	MAX.	
A	4.08	4.83	.160	.190	
A1	—	0.254	—	.010	
b	0.51	0.99	.020	.039	4
b1	0.51	0.89	.020	.035	
c	0.38	0.74	.015	.029	
e1	0.38	0.58	.015	.023	4
e2	1.14	1.65	.045	.065	
D	8.38	9.65	.330	.380	3
D1	8.86	—	.270	—	
E	9.65	10.87	.380	.420	3
E1	6.22	—	.245	—	
e	1.70 BSC	—	.067 BSC	—	
H	14.61	15.88	.575	.625	
L	1.78	2.79	.070	.110	
L1	—	1.68	—	.066	
L2	—	1.78	—	.070	
L3	0.25 BSC	—	.010 BSC	—	
L4	4.78	5.28	.188	.208	

Tape and reel – D²Pak

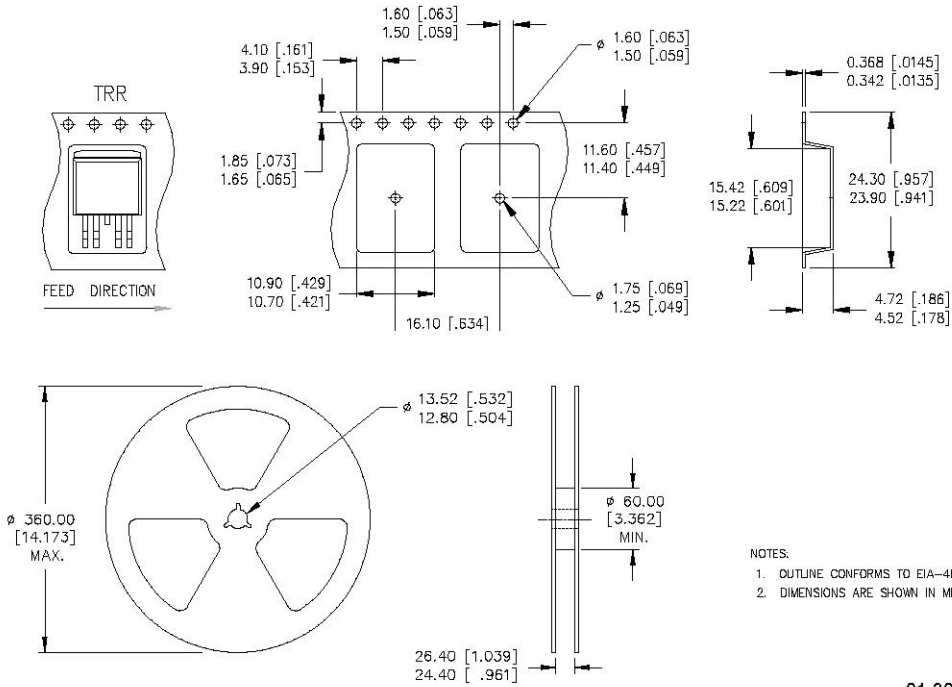

01-3071 00 / 01-3072 00

Case Outline - SO-8

Dimensions are shown in millimeters (inches)

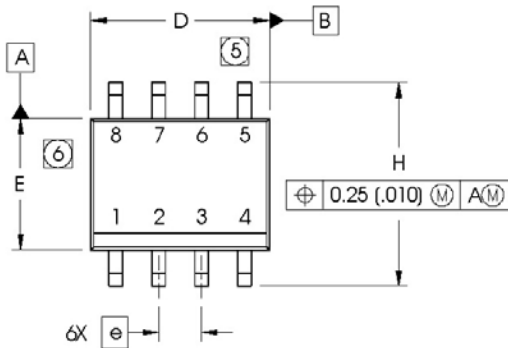

DIM	INCHES		MILLIMETERS	
	MIN	MAX	MIN	MAX
A	.0532	.0688	1.35	1.75
A1	.0040	.0098	0.10	0.25
b	.013	.020	0.33	0.51
c	.0075	.0098	0.19	0.25
D	.189	.1968	4.80	5.00
E	.1497	.1574	3.80	4.00
e	.050 BASIC		1.27 BASIC	
e1	.025 BASIC		0.635 BASIC	
H	.2284	.2440	5.80	6.20
K	.0099	.0196	0.25	0.50
L	.016	.050	0.40	1.27
y	0°	8°	0°	8°

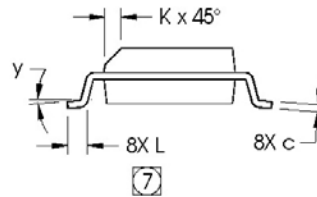
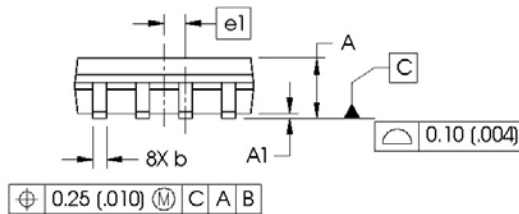

NOTES:

1. DIMENSIONING & TOLERANCING PER ASME Y14.5M-1994.
2. CONTROLLING DIMENSION: MILLIMETER
3. DIMENSIONS ARE SHOWN IN MILLIMETERS (INCHES).
4. OUTLINE CONFORMS TO JEDEC OUTLINE MS-012AA.
- 5 DIMENSION DOES NOT INCLUDE MOLD PROTRUSIONS. MOLD PROTRUSIONS NOT TO EXCEED 0.15 (.006).
- 6 DIMENSION DOES NOT INCLUDE MOLD PROTRUSIONS. MOLD PROTRUSIONS NOT TO EXCEED 0.25 (.010).
- 7 DIMENSION IS THE LENGTH OF LEAD FOR SOLDERING TO A SUBSTRATE.

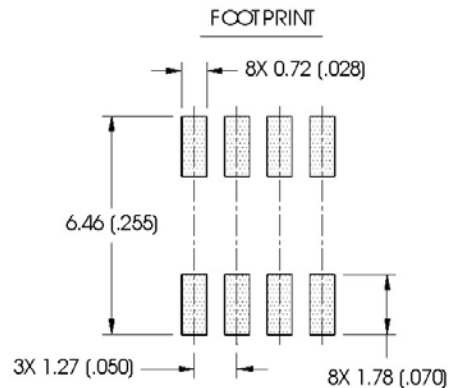

Tape & Reel - SO-8

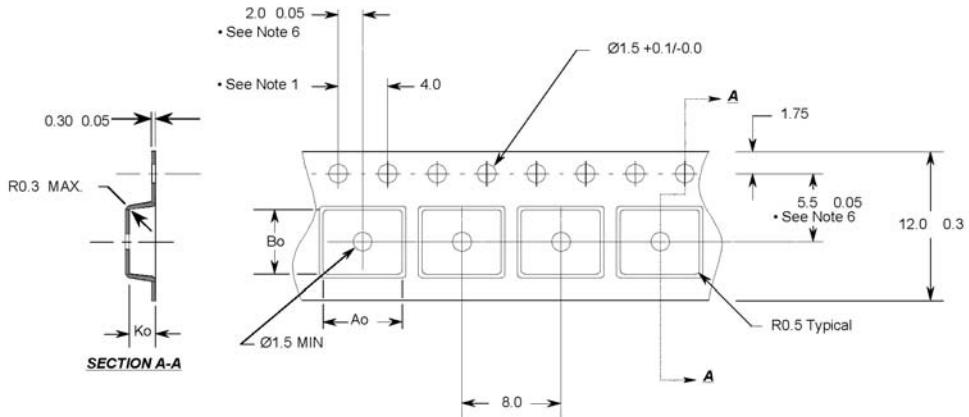

Notes:

1. 10 sprocket hole pitch cumulative tolerance 0.2
2. Camber not to exceed 1mm in 100mm
3. Material: Black Conductive Advantek Polystyrene
4. Ao and Bo measured on a plane 0.3mm above the bottom of the pocket
5. Ko measured from a plane on the inside bottom of the pocket to the top surface of the carrier.
6. Pocket position relative to sprocket hole measured as true position of pocket, not pocket hole.

Ao = 6.4 mm
 Bo = 5.2 mm
 Ko = 2.1 mm

- All Dimensions in Millimeters -

**REVISION HISTORY
 IPS7091G**

Revision No.	Date	PD No. & Rev. Letter	Page No.	Description	Reason of Change
1		60291_B	all	Add new package version : TO220 / D2pak	
2	09/09/08	60291_C	7	Add Rth=100°C/W figure 7	Information missing

Looking for pricing, stock, or lifecycle information?

Click below to explore more details on WIN SOURCE:

- [-](#) View [IPS7091GPBF](#) on WIN SOURCE
- [-](#) [Infineon Technologies](#) Information

Optimize Your Supply Chain with WIN SOURCE Solutions

- ✓ Global Sourcing Solution
- ✓ Obsolete Management
- ✓ Cost Control Management
- ✓ Shortage Management
- ✓ Alternative Solution
- ✓ Excess Inventory Management