

DATA SHEET

CBTS3306

Dual bus switch with Schottky diode clamping

Product data

2001 Nov 08

File under Integrated Circuits — ICL03

Dual bus switch with Schottky diode clamping

CBTS3306

FEATURES

- 5 Ω switch connection between two ports
- TTL-compatible input levels
- Package options include plastic small outline (SO) and thin shrink small outline (TSSOP)
- Latch-up protection exceeds 100 mA per JESD78
- ESD protection exceeds 2000 V HBM per JESD22-A114 and 1000 V CDM per JESD22-C101

DESCRIPTION

The CBTS3306 Dual FET Bus Switch features independent line switches with Schottky diodes on the I/Os to clamp undershoot. Each switch is disabled with the associated Output Enable (\overline{OE}) input is high.

The CBTS3306 is characterized for operation from -40 to +85 °C.

PIN CONFIGURATION

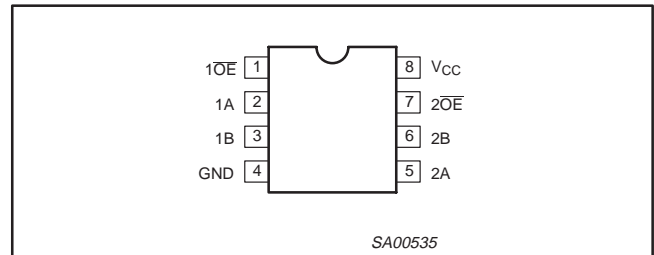

PIN DESCRIPTION

PIN NUMBER	SYMBOL	NAME AND FUNCTION
1, 7	$1\overline{OE}$, $2\overline{OE}$	Output enable
2, 5	1A, 2A	A port inputs
3, 6	1B, 2B	B port outputs
4	GND	Ground (0 V)
8	V_{CC}	Positive supply voltage

QUICK REFERENCE DATA

SYMBOL	PARAMETER	CONDITIONS $T_{amb} = 25\text{ °C}$; $GND = 0\text{ V}$	TYPICAL	UNIT
t_{PLH} t_{PHL}	Propagation delay A to B or B to A	$C_L = 50\text{ pF}$; $V_{CC} = +5.0\text{ V} \pm 0.5\text{ V}$	0.25 (MAX)	ns
$C_{IO(OFF)}$	Port off capacitance	$V_O = 3\text{ V}$ or 0; $\overline{OE} = V_{CC}$	7.60	pF
I_{CC}	Quiescent supply current	$V_{CC} = 5.5\text{ V}$; $I_O = 0$, $V_I = V_{CC}$ or GND	3	μA

ORDERING INFORMATION

PACKAGES	TEMPERATURE RANGE	ORDER CODE	DWG NUMBER
8-pin plastic SO	-40 to 85 °C	CBTS3306D	SOT96-1
8-pin plastic TSSOP	-40 to 85 °C	CBTS3306PW	SOT530-1

Standard packing quantities and other packaging data is available at www.philipslogic.com/packaging.

LOGIC DIAGRAM (positive logic)

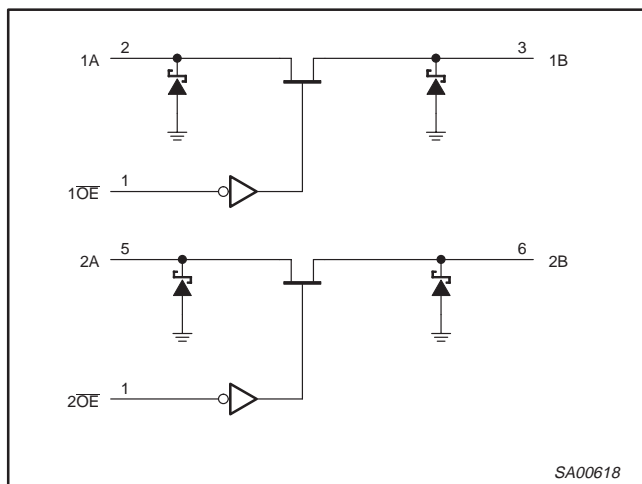

FUNCTION TABLE

INPUT	FUNCTION
\overline{OE}	
L	A port = B port
H	Disconnect

Dual bus switch with Schottky diode clamping

CBTS3306

ABSOLUTE MAXIMUM RATINGS¹ $T_{amb} = -40$ to $+85$ °C, unless otherwise specified.

SYMBOL	PARAMETER	CONDITIONS	RATING	UNIT
V_{CC}	DC supply voltage		-0.5 to +7.0	V
V_I	DC input voltage ²		-0.5 to +7.0	V
I_{OUT}	DC output current		128	mA
I_{IK}	Diode current	$V_{I/O} < 0$	-50	mA
T_{stg}	Storage temperature range		-65 to +150	°C

NOTES:

- Stresses beyond those listed may cause permanent damage to the device. These are stress ratings only and functional operation of the device at these or any other conditions beyond those indicated under "recommended operating conditions" is not implied. Exposure to absolute-maximum-rated conditions for extended periods may affect device reliability.
- The input and output negative-voltage ratings may be exceeded if the input and output clamp-current ratings are observed.
- The package thermal impedance is calculated in accordance with JESD 51.

RECOMMENDED OPERATING CONDITIONS¹

SYMBOL	PARAMETER	LIMITS		UNIT
		MIN	MAX	
V_{CC}	DC supply voltage	4.5	5.5	V
V_{IH}	High-level input voltage	2.0	—	V
V_{IL}	Low-level Input voltage	—	0.8	V
T_{amb}	Operating free-air temperature range	-40	+85	°C

NOTE:

- All unused control inputs of the device must be held at V_{CC} or GND to ensure proper device operation.

DC ELECTRICAL CHARACTERISTICS $T_{amb} = -40$ to $+85$ °C, unless otherwise specified.

SYMBOL	PARAMETER		TEST CONDITIONS	LIMITS			UNIT
				$T_{amb} = -40$ to $+85$ °C			
				MIN	TYP ¹	MAX	
V_{IK}	Input clamp voltage	A or B input	$V_{CC} = 4.5$ V; $I_I = -18$ mA	—	—	-0.7	V
		Control inputs	$V_{CC} = 4.5$ V; $I_I = -18$ mA	—	—	-1.2	
I_I	Input leakage current		$V_{CC} = 5.5$ V; $V_I =$ GND or 5.5 V	—	—	± 1	μ A
I_{CC}	Quiescent supply current		$V_{CC} = 5.5$ V; $I_O = 0$, $V_I = V_{CC}$ or GND	—	—	3	μ A
V_P	Output high pass voltage		$V_O = V_{CC} = 5.0$ V; $I_I = -100$ mA	3.4	3.6	3.9	V
ΔI_{CC}	Additional supply current per input pin ²		$V_{CC} = 5.5$ V, one input at 3.4 V, other inputs at V_{CC} or GND	—	—	2.5	mA
C_I	Control pin capacitance		$V_I = 3$ V or 0	—	3.25	—	pF
$C_{I(OFF)}$	Port off capacitance		$V_O = 3$ V or 0; $\overline{OE} = V_{CC}$	—	7.60	—	pF
r_{on} ³	On-resistance		$V_{CC} = 4.5$ V; $V_I = 0$ V; $I_I = 64$ mA	—	3.4	5	Ω
			$V_{CC} = 4.5$ V; $V_I = 0$ V; $I_I = 30$ mA	—	3.4	5	Ω
			$V_{CC} = 4.5$ V; $V_I = 2.4$ V; $I_I = 15$ mA	—	6.8	7.5	Ω

NOTES:

- All typical values are at $V_{CC} = 5$ V, $T_{amb} = 25$ °C.
- This is the increase in supply current for each input that is at the specified TTL voltage level rather than V_{CC} or GND.
- Measured by the voltage drop between the A and the B terminals at the indicated current through the switch. On-state resistance is determined by the lowest voltage of the two (A or B) terminals.

Dual bus switch with Schottky diode clamping

CBTS3306

AC CHARACTERISTICS

$T_{amb} = -40$ to $+85$ °C; $C_L = 50$ pF

SYMBOL	PARAMETER	FROM (INPUT)	TO (OUTPUT)	LIMITS		UNIT
				$V_{CC} = +5.0 V \pm 0.5 V$		
				MIN	MAX	
t_{pd}	Propagation delay ¹	A or B	B or A	—	0.25	ns
t_{en}	Output enable time to High and Low level	\overline{OE}	A or B	1.8	5	ns
t_{dis}	Output disable time from High and Low level	\overline{OE}	A or B	1	5	ns

NOTE:

1. The propagation delay is the calculated RC time constant of the typical on-state resistance of the switch and the specified load capacitance, when driven by an ideal voltage source (zero output impedance).

AC WAVEFORMS

$V_M = 1.5 V$, $V_{IN} = GND$ to $3.0 V$

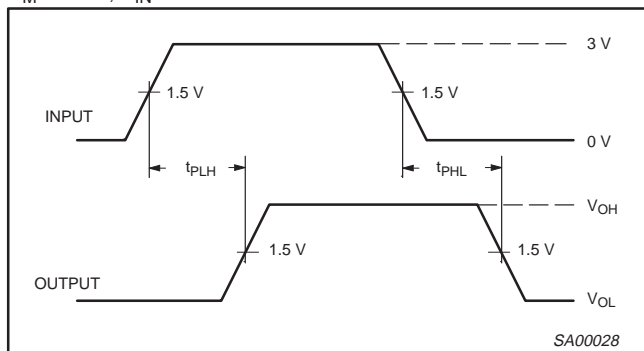

Waveform 1. Input to Output Propagation Delays

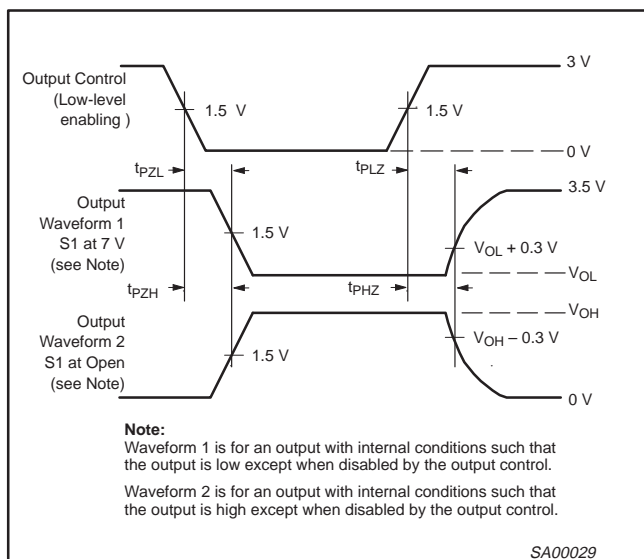

Waveform 2. 3-State Output Enable and Disable Times

NOTES:

1. t_{PLZ} and t_{PHZ} are the same as t_{dis} .
2. t_{PZL} and t_{PZH} are the same as t_{en} .
3. t_{PLH} and t_{PHL} are the same as t_{pd} .

TEST CIRCUIT AND WAVEFORMS

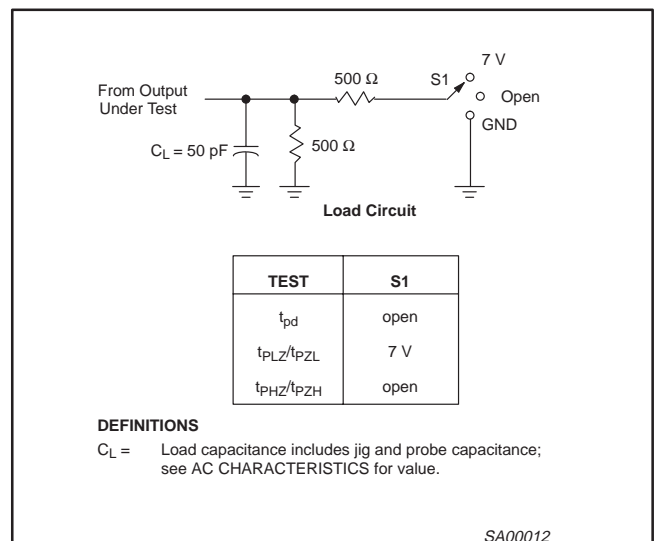

NOTES:

1. All input pulses are supplied by generators having the following characteristics: $PRR \leq 10$ MHz, $Z_O = 50 \Omega$, $t_r \leq 2.5$ ns, $t_f \leq 2.5$ ns.
2. The outputs are measured one at a time with one transition per measurement.

Dual bus switch with Schottky diode clamping

CBTS3306

TSSOP8: plastic thin shrink small outline; 8 leads; body width 4.4 mm

SOT530-1

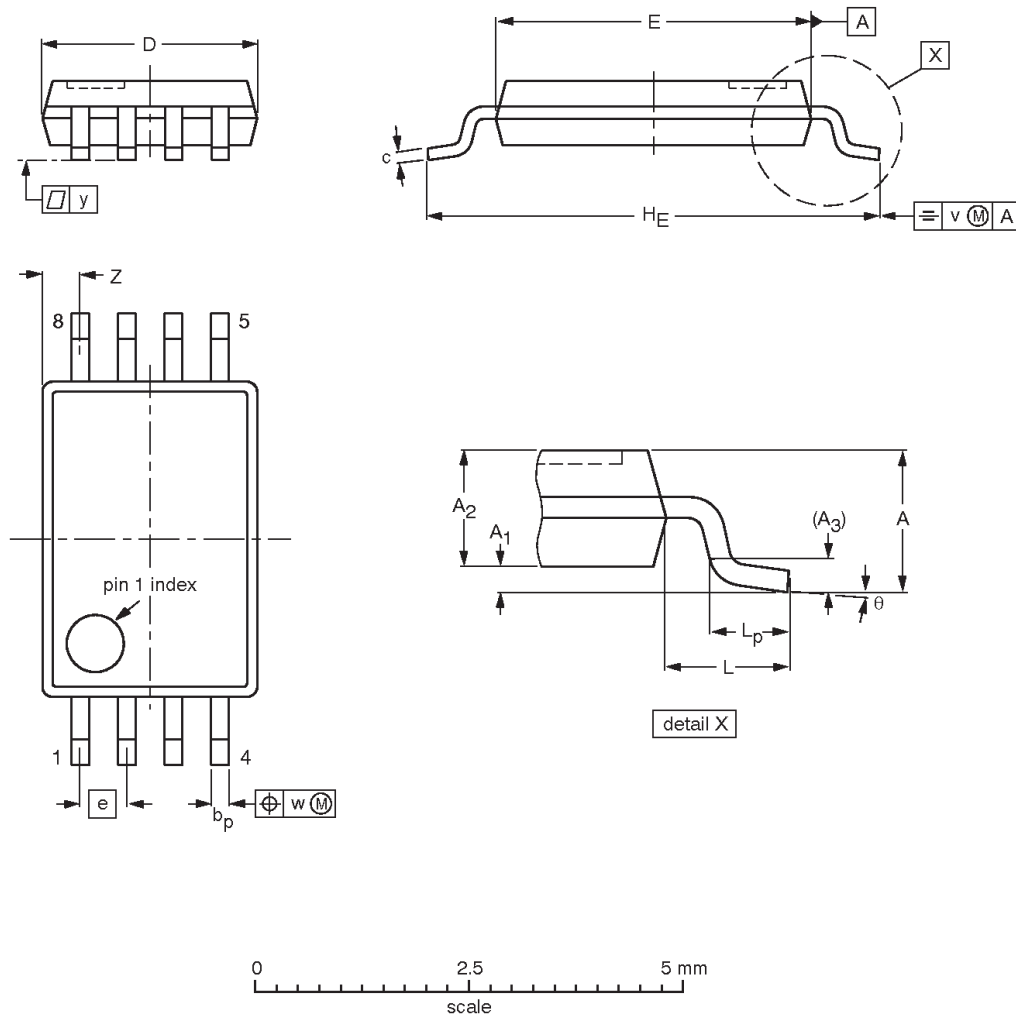

DIMENSIONS (mm are the original dimensions)

UNIT	A max.	A ₁	A ₂	A ₃	b _p	c	D ⁽¹⁾	E ⁽²⁾	e	H _E	L	L _p	v	w	y	Z ⁽¹⁾	θ
mm	1.10	0.15 0.05	0.95 0.85	0.25	0.30 0.19	0.20 0.13	3.10 2.90	4.50 4.30	0.65	6.50 6.30	0.94	0.70 0.50	0.10	0.10	0.10	0.70 0.35	8° 0°

Notes

1. Plastic or metal protrusions of 0.15 mm maximum per side are not included.
2. Plastic or metal protrusions of 0.25 mm maximum per side are not included.

OUTLINE VERSION	REFERENCES				EUROPEAN PROJECTION	ISSUE DATE
	IEC	JEDEC	EIAJ			
SOT530-1		MO-153				99-12-27 00-02-24

Dual bus switch with Schottky diode clamping

CBTS3306

S08: plastic small outline package; 8 leads; body width 3.9 mm

SOT96-1

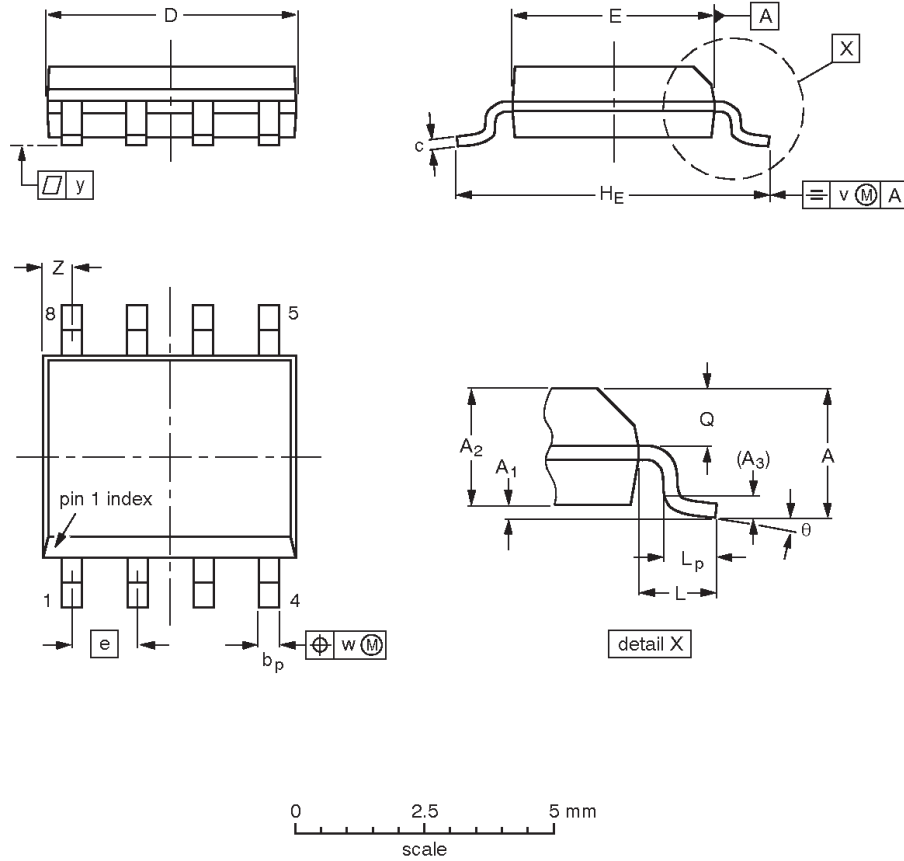

DIMENSIONS (inch dimensions are derived from the original mm dimensions)

UNIT	A max.	A ₁	A ₂	A ₃	b _p	c	D ⁽¹⁾	E ⁽²⁾	e	H _E	L	L _p	Q	v	w	y	Z ⁽¹⁾	θ
mm	1.75	0.25 0.10	1.45 1.25	0.25	0.49 0.36	0.25 0.19	5.0 4.8	4.0 3.8	1.27	6.2 5.8	1.05	1.0 0.4	0.7 0.6	0.25	0.25	0.1	0.7 0.3	8° 0°
inches	0.069	0.010 0.004	0.057 0.049	0.01	0.019 0.014	0.0100 0.0075	0.20 0.19	0.16 0.15	0.050	0.244 0.228	0.041	0.039 0.016	0.028 0.024	0.01	0.01	0.004	0.028 0.012	

Notes

1. Plastic or metal protrusions of 0.15 mm maximum per side are not included.
2. Plastic or metal protrusions of 0.25 mm maximum per side are not included.

OUTLINE VERSION	REFERENCES				EUROPEAN PROJECTION	ISSUE DATE
	IEC	JEDEC	EIAJ			
SOT96-1	076E03	MS-012				97-05-22 99-12-27

Dual bus switch with Schottky diode clamping

CBTS3306

NOTES

Dual bus switch with Schottky diode clamping

CBTS3306

Data sheet status

Data sheet status ^[1]	Product status ^[2]	Definitions
Objective data	Development	This data sheet contains data from the objective specification for product development. Philips Semiconductors reserves the right to change the specification in any manner without notice.
Preliminary data	Qualification	This data sheet contains data from the preliminary specification. Supplementary data will be published at a later date. Philips Semiconductors reserves the right to change the specification without notice, in order to improve the design and supply the best possible product.
Product data	Production	This data sheet contains data from the product specification. Philips Semiconductors reserves the right to make changes at any time in order to improve the design, manufacturing and supply. Changes will be communicated according to the Customer Product/Process Change Notification (CPCN) procedure SNW-SQ-650A.

[1] Please consult the most recently issued data sheet before initiating or completing a design.

[2] The product status of the device(s) described in this data sheet may have changed since this data sheet was published. The latest information is available on the Internet at URL <http://www.semiconductors.philips.com>.

Definitions

Short-form specification — The data in a short-form specification is extracted from a full data sheet with the same type number and title. For detailed information see the relevant data sheet or data handbook.

Limiting values definition — Limiting values given are in accordance with the Absolute Maximum Rating System (IEC 60134). Stress above one or more of the limiting values may cause permanent damage to the device. These are stress ratings only and operation of the device at these or at any other conditions above those given in the Characteristics sections of the specification is not implied. Exposure to limiting values for extended periods may affect device reliability.

Application information — Applications that are described herein for any of these products are for illustrative purposes only. Philips Semiconductors make no representation or warranty that such applications will be suitable for the specified use without further testing or modification.

Disclaimers

Life support — These products are not designed for use in life support appliances, devices or systems where malfunction of these products can reasonably be expected to result in personal injury. Philips Semiconductors customers using or selling these products for use in such applications do so at their own risk and agree to fully indemnify Philips Semiconductors for any damages resulting from such application.

Right to make changes — Philips Semiconductors reserves the right to make changes, without notice, in the products, including circuits, standard cells, and/or software, described or contained herein in order to improve design and/or performance. Philips Semiconductors assumes no responsibility or liability for the use of any of these products, conveys no license or title under any patent, copyright, or mask work right to these products, and makes no representations or warranties that these products are free from patent, copyright, or mask work right infringement, unless otherwise specified.

Contact information

For additional information please visit
<http://www.semiconductors.philips.com>. Fax: +31 40 27 24825

© Koninklijke Philips Electronics N.V. 2001
 All rights reserved. Printed in U.S.A.

Date of release: 11-01

For sales offices addresses send e-mail to:
sales.addresses@www.semiconductors.philips.com

Document order number:

9397 750 09117

Let's make things better.

Looking for pricing, stock, or lifecycle information?

Click below to explore more details on WIN SOURCE:

 [View CBTS3306PW+118](#) on WIN SOURCE

 [NXP / Nexperia](#) Information

Optimize Your Supply Chain with WIN SOURCE Solutions

-  Global Sourcing Solution
-  Obsolete Management
-  Cost Control Management
-  Shortage Management
-  Alternative Solution
-  Excess Inventory Management