



**THE DATASHEET OF  
SFSD-10-30-G-58.20-D-NDX**



DO NOT  
SCALE FROM  
THIS PRINT

**DESIGNED & DIMENSIONED  
IN INCHES [MILLIMETERS]**

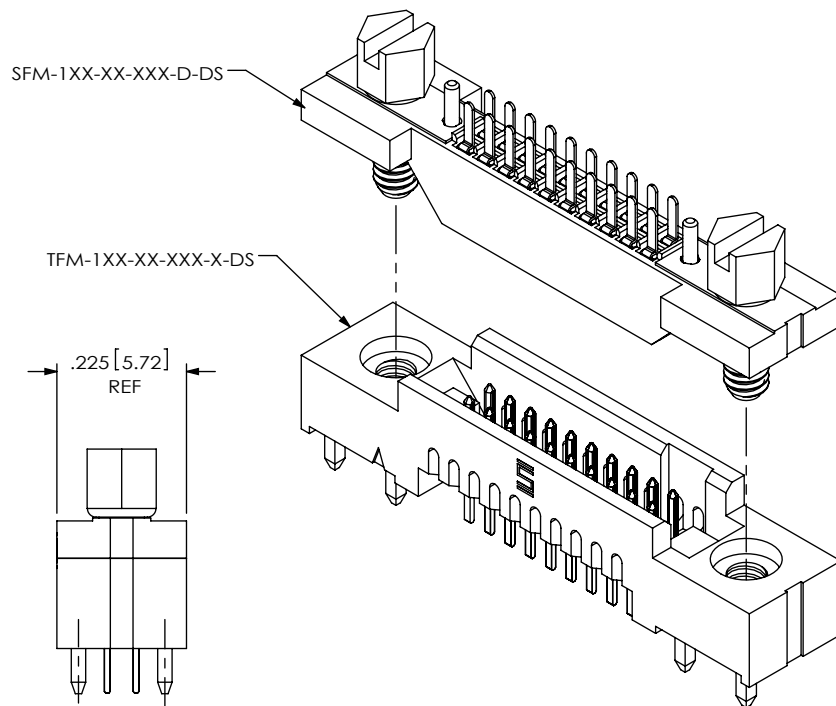
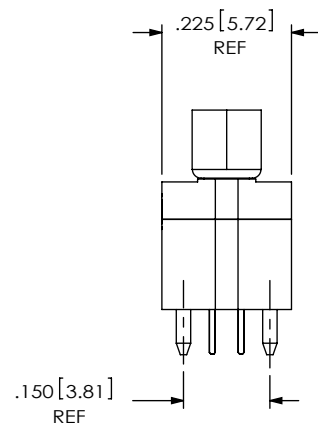
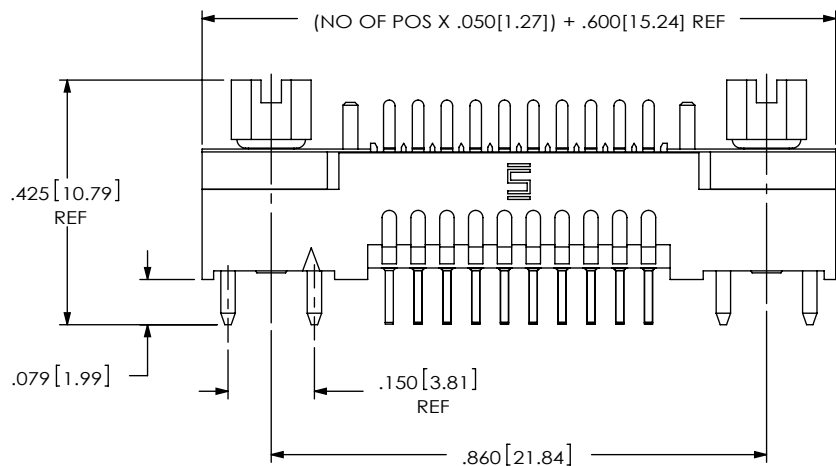

**FIG 1**  
TFM-1XX-XX-XXX-X-DS & SFM-1XX-XX-XXX-D-DS MATING

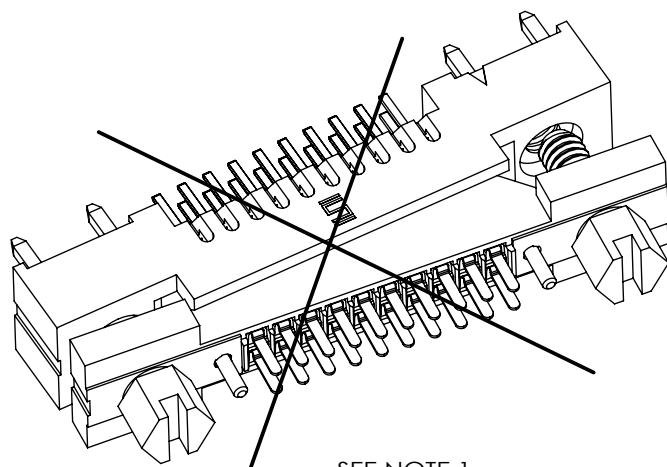

SEE NOTE 1

NOTES:

1. SCREWS MUST BE TIGHTENED IN .060" INCREMENTS, ALTERNATING SIDE TO SIDE; TIGHTEN FASTNERS TO 8 IN OZ MAX.
2. STANDARD .100" SCREW DRIVER RECOMMENDED.

**PROPRIETARY NOTE**

THIS DOCUMENT CONTAINS INFORMATION CONFIDENTIAL AND PROPRIETARY TO SAMTEC, INC. AND SHALL NOT BE REPRODUCED OR TRANSFERRED TO OTHER DOCUMENTS OR DISCLOSED TO OTHERS OR USED FOR ANY PURPOSE OTHER THAN THAT WHICH IT WAS OBTAINED WITHOUT THE EXPRESSED WRITTEN CONSENT OF SAMTEC, INC.

DO NOT SCALE DRAWING

SHEET SCALE: 4:1



520 PARK EAST BLVD, NEW ALBANY, IN 47150  
PHONE: 812-944-6733 FAX: 812-948-5047  
e-Mail info@SAMTEC.com code 55322

DESCRIPTION: **SCREW DOWN APPLICATION**

DWG. NO. TFM SFM SFSD ISDF SCREW DOWN OPTION APPLICATION

BY: ROY LUO 07/09/2011 SHEET 1 OF 3

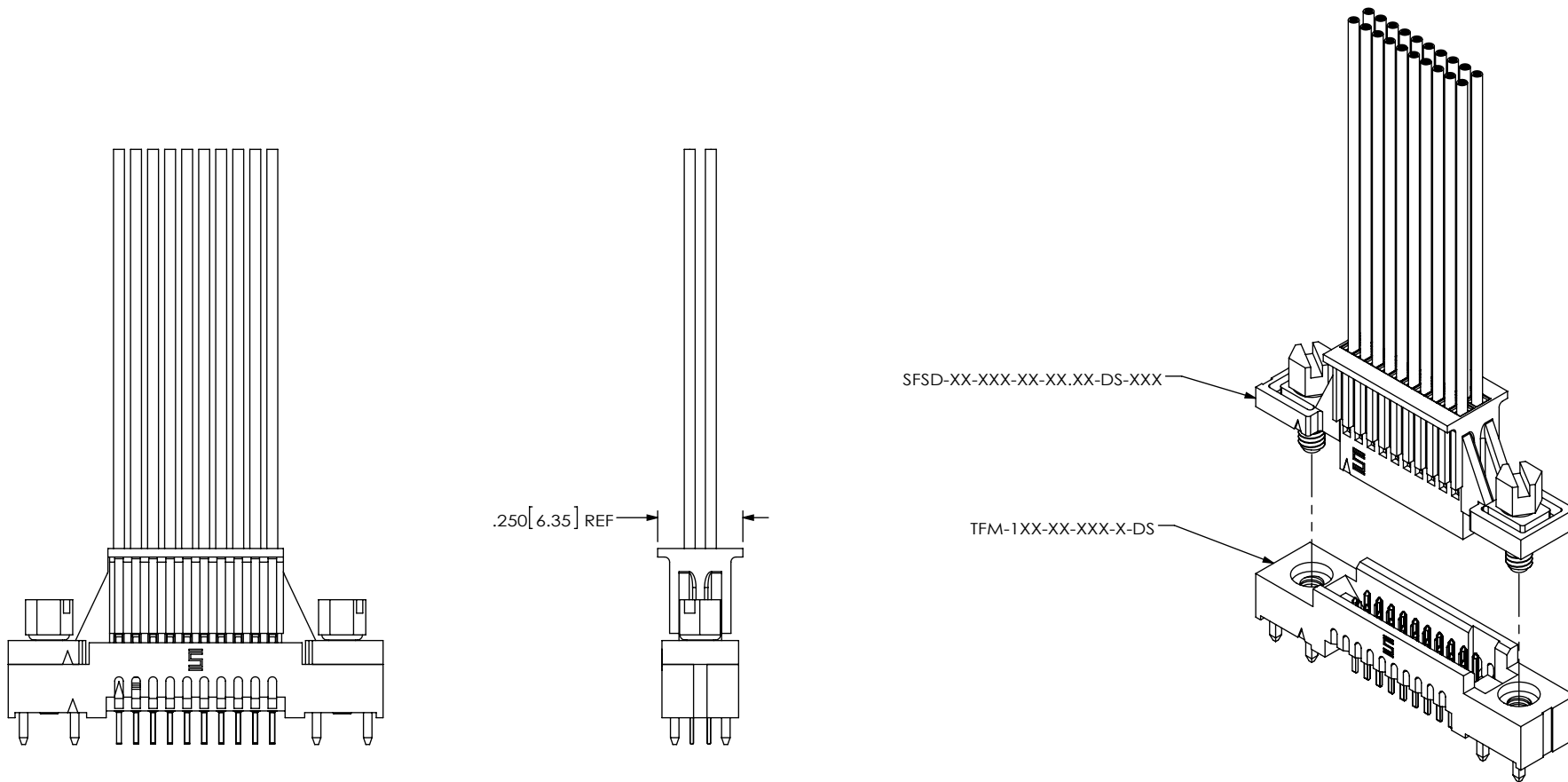



FIG 2  
TFM-1XX-XX-XXX-X-DS & SFSD-XX-XXX-XX-XX.XX-DS-XXX MATING  
(SAME AS FIG 1, UNLESS OTHERWISE STATED)

<p><b>PROPRIETARY NOTE</b> THIS DOCUMENT CONTAINS INFORMATION CONFIDENTIAL AND PROPRIETARY TO SAMTEC, INC. AND SHALL NOT BE REPRODUCED OR TRANSFERRED TO OTHER DOCUMENTS OR DISCLOSED TO OTHERS OR USED FOR ANY PURPOSE OTHER THAN THAT WHICH IT WAS OBTAINED WITHOUT THE EXPRESSED WRITTEN CONSENT OF SAMTEC, INC.</p> <p>DO NOT SCALE DRAWING</p> <p>SHEET SCALE: 2:1</p>		
	<p>520 PARK EAST BLVD, NEW ALBANY, IN 47150 PHONE: 812-944-6733 FAX: 812-948-5047 e-Mail: info@SAMTEC.com code 55322</p>	
	<p>DESCRIPTION: <b>SCREW DOWN APPLICATION</b></p>	
	<p>DWG. NO. TFM SFM SFSD ISDF SCREW DOWN OPTION APPLICATION</p>	
<p>BY: ROY LUO 07/09/2011</p>		<p>SHEET 2 OF 3</p>

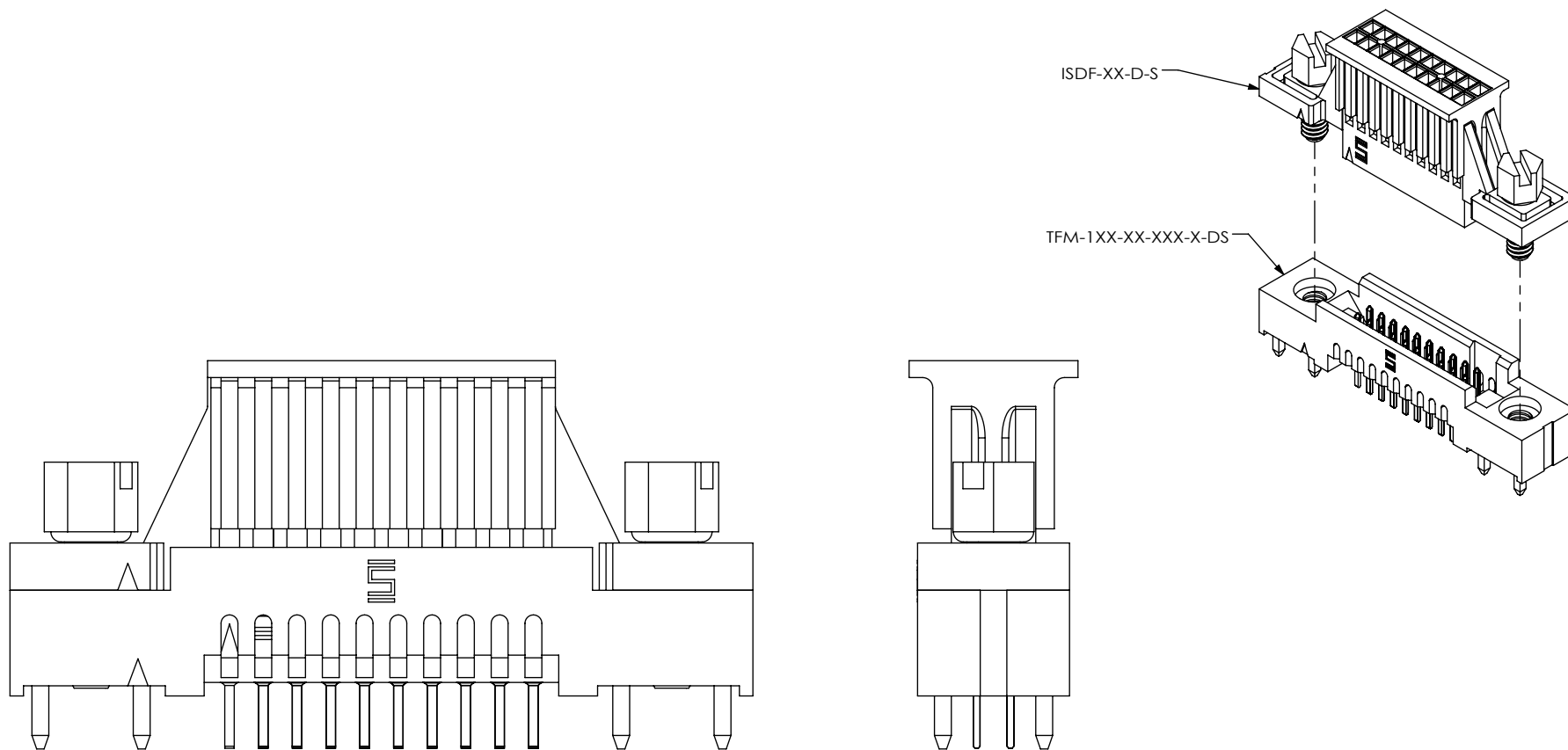

FIG 3  
TFM-1XX-XX-XXX-X-DS & ISDF-XX-D-S MATING  
(SAME AS FIG 1, UNLESS OTHERWISE STATED)

**PROPRIETARY NOTE**

THIS DOCUMENT CONTAINS INFORMATION CONFIDENTIAL AND PROPRIETARY TO SAMTEC, INC. AND SHALL NOT BE REPRODUCED OR TRANSFERRED TO OTHER DOCUMENTS OR DISCLOSED TO OTHERS OR USED FOR ANY PURPOSE OTHER THAN THAT WHICH IT WAS OBTAINED WITHOUT THE EXPRESSED WRITTEN CONSENT OF SAMTEC, INC.

DO NOT SCALE DRAWING

SHEET SCALE: 4:1



520 PARK EAST BLVD, NEW ALBANY, IN 47150  
PHONE: 812-944-6733 FAX: 812-948-5047  
e-Mail info@SAMTEC.com code 55322



DESCRIPTION:  
SCREW DOWN APPLICATION

DWG. NO.  
TFM SFM SFSD ISDF SCREW DOWN OPTION APPLICATION

BY: ROY LUO 07/09/2011 SHEET 3 OF 3

## Looking for pricing, stock, or lifecycle information?

Click below to explore more details on WIN SOURCE:

-  [View SFSD-10-30-G-58.20-D-NDX on WIN SOURCE](#)
-  [Samtec Inc. Information](#)

## Optimize Your Supply Chain with WIN SOURCE Solutions

-  Global Sourcing Solution
-  Obsolete Management
-  Cost Control Management
-  Shortage Management
-  Alternative Solution
-  Excess Inventory Management