



**THE DATASHEET OF
EV1HMC7545ABLP47**





HMC7545AxLP47

14.2 Gbps 4-Channel Asynchronous Signal Conditioner Evaluation Board (EVB) User Guide

User Guide

Part # 140-00153-00

ECN# CP140238

Hittite Microwave Corporation
2 Elizabeth Dr Chelmsford, MA 01824
United States

www.hittite.com

Contents

| | |
|--|-------|
| Introduction | p. 3 |
| HMC7545AxLP47 EVB Signal Descriptions | p. 6 |
| HMC7545AxLP47 Operational Modes | p. 7 |
| HMC7545AxLP47 EVB Lab Equipment Configuration | p. 14 |
| HMC7545AxLP47 EVB Operating Instructions | p. 15 |
| HMC7545AxLP47 EVB Equalization (EQ) and De-Emphasis (DE) Operation | p. 23 |

1 Introduction

The HMC7545AxLP47 is a uni-directional quad channel asynchronous signal conditioner designed for serial links, operating up to 14.2 Gbps, of short and intermediate optical modules, linecards, and backplane applications. HMC7545AxLP47 can be used either on the receiver or transmitter path for compensating signal impairments by means of input Equalization (EQ) and output De-Emphasis (DE) functions. The HMC7545AxLP47 is protocol and datarate agnostic and ideal for SAS/SATA, PCIe, Fibre Channel, Infiniband, and Ethernet applications.

The HMC7545AxLP47 4-Channel Signal Conditioner Evaluation Board (EVB) is available for internal characterization at Customer sites. This document provides operating instructions and guidelines for the HMC7545AxLP47 EVB. There are two versions of this part: HMC7545ABLP47 2-Tap FIR Tx and HMC7545AALP47 3-Tap FIR Tx. Please refer to the HMC7545AxLP47 datasheet for product specifications.

The HMC7545AxLP47 operates at data rates up to 14.2 Gb/s. Its primary function is to compensate for channel losses due to long backplane, or other lengthy system PCB traces using FR4 dielectric transmission lines, for example. These compensation circuits consist of channel equalization (EQ) at the inputs, and channel pre-emphasis (PE) at the outputs, as shown in the functional diagram in [Figure 1](#).

The HMC7545AxLP47 typically operates on a +2.5V power supply, but can also run on +3.3V. The HMC7545AxLP47 operation is specified at 88 mW/ channel under typical conditions.

All 4 input and 4 output signals of the HMC7545AxLP47 4-Channel Signal Conditioner are accessible via SMA connectors on the EVB. This is shown in [Figure 2](#). The input channels are: IN0P/N, IN1P/N, IN2P/N, IN3P/N and the output channels are: OUT0P/N, OUT1P/N, OUT2P/N, OUT3P/N. These I/O channel signals are AC-coupled on the EVB using 100nF ultra-broadband coupling capacitors to facilitate interfacing to ground-referenced test equipment, such as PRBS pattern generators (inputs), and Oscilloscopes (outputs).

Transmission line load boards of various lengths, and representing real-world lossy channel conditions, can be attached to the EVB via the SMA connectors at inputs or outputs. Lossy channels can be used in this way to demonstrate the Signal Integrity improvements of the Pre-Emphasis (PE) and Equalization (EQ) features of the HMC7545AxLP47.

A photograph of the physical HMC7545AxLP47 EVB is given in [Figure 3](#), and shows component locations, power connections, USB connector, jumpers, and I/O signal orientation.

The HMC7545AxLP47 can be configured via one of the three modes of operation, as described, below.

1) Parallel Mode

Parallel Mode uses jumpers provided on the EVB to configure the HMC7545AxLP47.

2) I2C Mode

The HMC7545AxLP47 EVB Graphical User Interface (GUI) is used in I2C mode to set the values of the internal registers to default settings, or user-defined values. A register map is included in the data sheet.

3) EEPROM Mode

This mode uses the EEPROM on the EVB to store register values. The GUI is used to enter and optimize these settings. The HMC7545AxLP47 will then operate using the settings stored on the EEPROM.

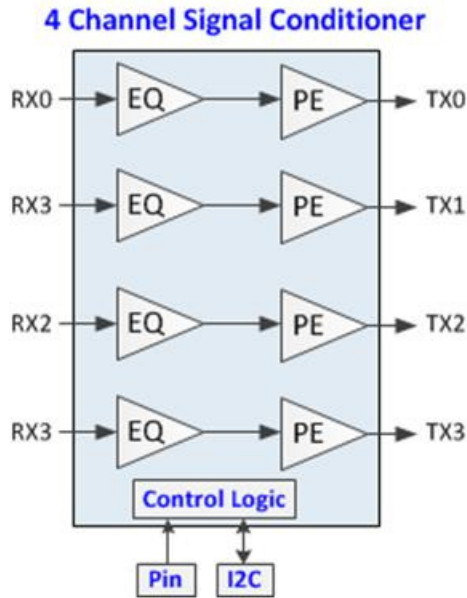

Figure 1: HMC7545AxLP47 4-Channel Signal Conditioner: Functional Diagram

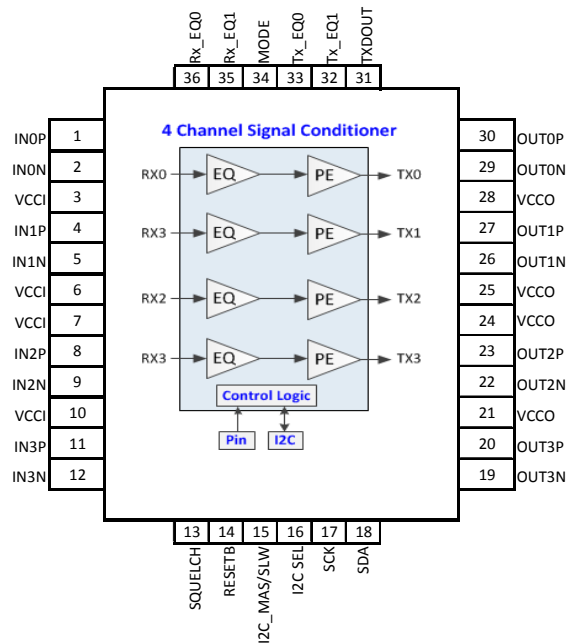

Figure 2: HMC7545AxLP47 4-Channel Signal Conditioner: Pin Names

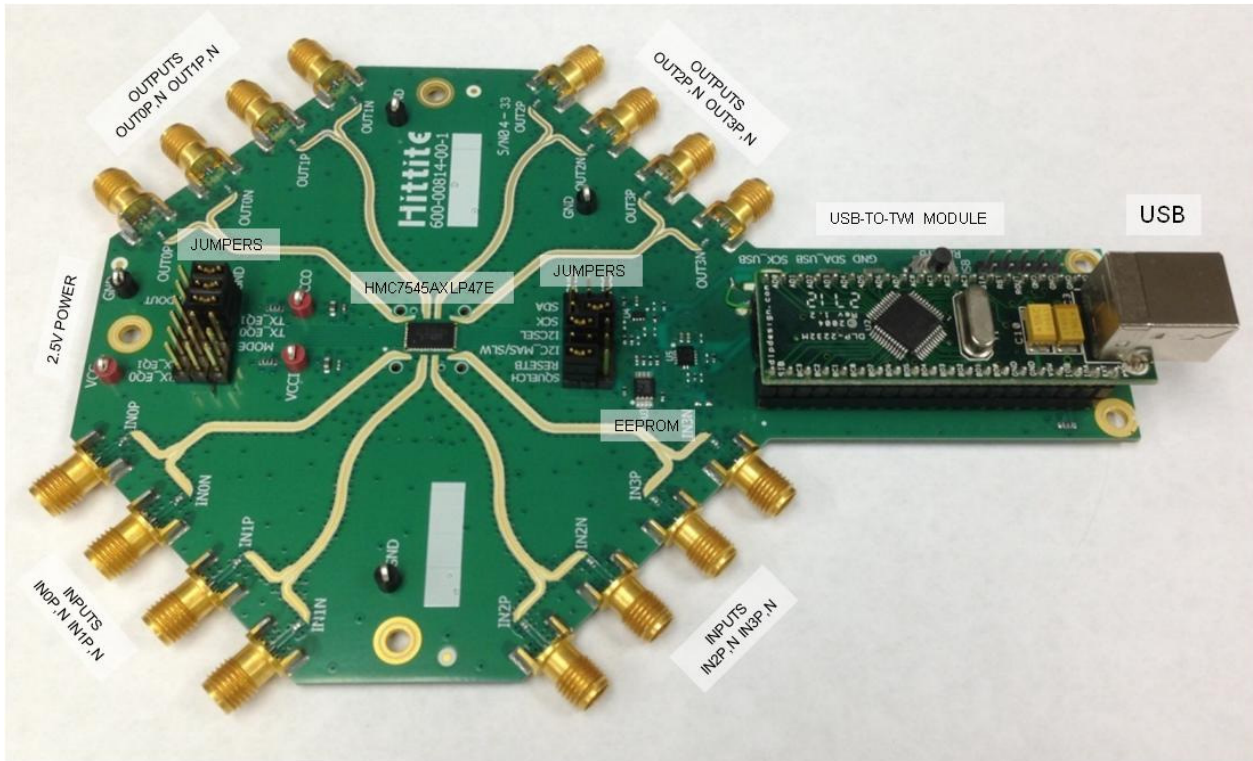

Figure 3. Photo of HMC7545AxLP47 Evaluation Board (EVB)

2 HMC7545AxLP47 Signal Descriptions

Table 1 summarizes the HMC7545AxLP47 signals and their respective functions.

Table 1: HMC7545AxLP47 Signal Names and Functions

| Signal Name | Signal Description |
|-----------------|---|
| IN(0-3)P and N | Differential RF inputs with independent programmable Equalization (EQ) |
| OUT(0-3P) and N | Differential RF outputs with independent programmable De-Emphasis (DE) |
| VCCI | Power supply pin for all inputs |
| VCCO | Power supply pin for all outputs |
| SQUELCH | SQUELCH all outputs. Active HI = 1 |
| RESETB | Global RESET. Active LO = 0 |
| I2C_MAS/SLV | I2C Master Mode, or Slave Mode Select. Master = HI = 1, Slave = LO = 0 |
| I2CSEL | Parallel Mode, or I2C Mode Select Parallel Mode = LO = 0, I2C Mode = HI = 1 |
| SCK | Clock pin for the 2 wire interface (I2C/TWI) |
| SDA | Data pin for the 2 wire interface (I2C/TWI) |
| RX_EQ0 | LSB of the CTLE settings while in parallel mode |
| RX_EQ1 | MSB of the CTLE settings while in parallel mode |
| MODE | Selects between high and low speed operation |
| TX_EQ0 | Dual purpose: <ul style="list-style-type: none"> - Set the chip address in I2C Mode. - LSB of De-Emphasis settings in Parallel Mode |
| TX_EQ1 | Dual purpose: <ul style="list-style-type: none"> - Set the chip address in I2C Mode. - MSB of De-Emphasis settings in Parallel Mode |
| TXDOUT | Dual purpose: <ul style="list-style-type: none"> - Set the chip address in I2C Mode. - Set the amplitude in parallel mode |

3 HMC7454AxLP47E EVB Operational Modes

The HMC7454AxLP47E provides three modes of operation: 1) Parallel mode using jumpers on EVB, 2) I2C mode using GUI PC interface, and 3) EEPROM mode, from EEPROM on EVB.

3.1 Parallel Mode (Direct Pin Control)

There are two banks of jumpers on the HMC7454AxLP47 EVB. Each bank has six signals that can be set to 1 = VCC, 0 = GND, or X = MID-LEVEL via jumpers. The jumpers are shown in the EVB photo provided in [Figure 3](#). The signals and nominal jumper settings are provided in [Tables 2 and 3](#), below.

Table 2: Parallel Mode: Jumper Bank 1

| Signal Name | Signal Description | Parallel Mode Settings |
|-------------|--|------------------------|
| SQUELCH | SQUELCH all outputs. Active HI | 0 = GND |
| RESETB | Global RESET. Active LO | 1 = VCC |
| I2C_MAS/SLV | I2C Master Mode, or Slave Mode Select. Master = HI, Slave = LO | 0 = GND |
| I2CSEL | Parallel Mode (LO) or normal I2C Mode (HI) Select | 0 = GND |
| SCK | Clock pin for the 2 wire interface | X = MID-LEVEL |
| SDA | Data pin for the 2 wire interface | X = MID-LEVEL |

Table 3: Parallel Mode: Jumper Bank 2

| Signal Name | Signal Description | Parallel Mode Settings |
|-------------|---|---------------------------------------|
| RX_EQ0 | LSB of the CTLE settings while in parallel mode | Per Table 4 Default: X = MID-LEVEL |
| RX_EQ1 | MSB of the CTLE settings while in parallel mode | Per Table 4 Default: X = MID-LEVEL |
| MODE | Selects high or low speed operation: Low Speed = LO, High Speed = HI | 1 = VCC |
| TX_EQ0 | Dual purpose: - Set the chip address in I2C Mode. - LSB of De-Emphasis settings in Parallel Mode | Per Table 5 Default: 0 = GND |
| TX_EQ1 | Dual purpose: - Set the chip address in I2C Mode. - MSB of De-Emphasis settings in Parallel Mode | Per Table 5 Default: 0 = GND |
| TXDOUT | Dual purpose: - Set the chip address in I2C Mode. - Set the amplitude in parallel mode | Per Table 5 Default: 0 = GND |

Pins RX_EQ[1:0] control the Rx CTLE EQ settings. These pins are tri-state control pins. The three different levels are defined as follows, as shown in [Table 4](#).

0 = GND X = MID-LEVEL 1 = VCC

Table 4: Input Rx EQ: Parallel Mode (Direct Pin Control) Range of Settings

| EQ_LEVEL[1:0] (decimal) | CTLE Equalization (dB) |
|------------------------------------|-----------------------------------|
| 00 (1) | -1.1 |
| 0X (2) | -2.8 |
| 01 (3) | -4.6 |
| X0 (4) | -5.4 |
| XX (5) | -7.3 |
| X1 (6) | -9.1 |
| 10 (7) | -12.2 |
| 1X (8) | -15.5 |
| 11 (9) | -17.8 |

Pins TXDOUT and TX_EQ[1:0] control the TX DE settings. These pins are tri-state control pins. The three different levels are defined as follows, as shown in [Table 5](#).

0 = GND X = MID-LEVEL 1 = VCC

Table 5: Output Tx DE: Parallel Mode (Direct Pin Control) Range of Settings

| TXDOUT | TX_EQ[1:0] | De-Emphasis (dB) | Note |
|--------|------------|------------------|-------|
| 0 | 00 | 0 | PCI 1 |
| 0 | 0X | -1.63 | PCI 2 |
| 0 | X0 | -3.3 | PCI 5 |
| 0 | 01 | -5.02 | PCI 3 |
| 0 | XX | -6.85 | PCI 6 |
| 0 | X1 | -8.83 | 8db |
| 0 | 10 | -11.06 | 10db |
| 0 | 1X | -13.66 | 12db |
| 0 | 11 | -16.9 | 12db |
| 1 | 00 | 0 | PCI 1 |
| 1 | 0X | -1.63 | PCI 2 |
| 1 | 01 | -3.3 | PCI 3 |
| 1 | X0 | -5.02 | PCI 5 |
| 1 | XX | -6.85 | PCI 6 |
| 1 | X1 | -8.83 | 8db |
| 1 | 10 | -11.06 | 10db |
| 1 | 1X | -13.66 | 12db |
| 1 | 11 | -16.9 | 12db |
| 2 | 00 | 0 | PCI 1 |
| 2 | 0X | -1.11 | PCI 2 |
| 2 | 01 | -2.23 | PCI 3 |
| 2 | X0 | -3.6 | PCI 5 |
| 2 | XX | -5.38 | PCI 6 |
| 2 | X1 | -7.71 | 8db |
| 2 | 10 | -11.87 | 10db |
| 2 | 1X | -15.72 | 12db |
| 2 | 11 | -19.4 | 12db |

3.2 I2C Mode (GUI control)

I2C mode is the standard method to operate, and evaluate the HMC7545AxLP47 using the EVB. This mode uses I2C communications and the Graphical User Interface (GUI) via PC to set register values for optimized signal conditioner performance.

There are two banks of jumpers on the HMC7545AxLP47 EVB. Each bank has six signals that can be set to 1 = VCC, 0 = GND, or X = MID-LEVEL via. jumpers. The jumpers are shown in the EVB photo provided in [Figure 3](#). The signals and nominal jumper settings are provided in [Tables 6 and 7](#), below.

Table 6: I2C Mode: Jumper Bank 1

| Signal Name | Signal Description | I2C Mode Settings |
|-------------|--|-------------------|
| SQUELCH | SQUELCH all outputs. Active HI | 0 = GND |
| RESETB | Global RESET. Active LO | 1 = VCC |
| I2C_MAS/SLV | I2C Master Mode, or Slave Mode Select. Master = HI, Slave = LO | 0 = GND |
| I2CSEL | Parallel Mode (LO) or normal I2C Mode (HI) Select | 1 = VCC |
| SCK | Clock pin for the 2 wire interface | X = MID-LEVEL |
| SDA | Data pin for the 2 wire interface | X = MID-LEVEL |

Table 7: I2C Mode: Jumper Bank 2

| Signal Name | Signal Description | I2C Mode Settings |
|-------------|---|-------------------|
| RX_EQ0 | LSB of the CTLE settings while in parallel mode | X = MID-LEVEL |
| RX_EQ1 | MSB of the CTLE settings while in parallel mode | X = MID-LEVEL |
| MODE | Selects high or low speed operation: Low Speed = LO, High Speed = HI | 1 = VCC |
| TX_EQ0 | Dual purpose: - Set the chip address in I2C Mode. - LSB of De-Emphasis settings in Parallel Mode | X = MID-LEVEL |
| TX_EQ1 | Dual purpose: - Set the chip address in I2C Mode. - MSB of De-Emphasis settings in Parallel Mode | 0 = GND |
| TXDOUT | Dual purpose: - Set the chip address in I2C Mode. - Set the amplitude in parallel mode | 0 = GND |

In I2C mode, the input EQ settings are controlled by the REG10[4:0] bits (EQ_LEVEL[4:0]). The amount of equalization achieved for each value in this register for CTLE EQ is shown in [Table 8](#).

Table 8: Input Rx EQ:I2C Mode Settings

| EQ_LEVEL[4:0] (dec) | dB | EQ_LEVEL[4:0] (dec) | dB |
|------------------------|------|------------------------|-------|
| 0 | 0 | 16 | -5.1 |
| 1 | -0.3 | 17 | -5.4 |
| 2 | -0.7 | 18 | -5.7 |
| 3 | -1.1 | 19 | -6.1 |
| 4 | -1.5 | 20 | -6.4 |
| 5 | -1.8 | 21 | -6.9 |
| 6 | -2.2 | 22 | -7.3 |
| 7 | -2.5 | 23 | -7.8 |
| 8 | -2.8 | 24 | -8.4 |
| 9 | -3.1 | 25 | -9.1 |
| 10 | -3.4 | 26 | -10 |
| 11 | -3.7 | 27 | -11 |
| 12 | -4 | 28 | -12.2 |
| 13 | -4.3 | 29 | -13.7 |
| 14 | -4.6 | 30 | -15.5 |
| 15 | -4.8 | 31 | -17.8 |

Output DE setting range for I2C Mode is given in [Table 9](#).

Table 9: Output Tx DE: I2C Mode Settings

| Register/bits | Function |
|---------------|--------------|
| REG5[3:0] | TX_PRE[3:0] |
| REG6[4:0] | TX_MAIN[4:0] |
| REG7[5:0] | TX_POST[5:0] |
| REG8[4:0] | DELAY1[4:0] |
| REG9[4:0] | DELAY2[4:0] |

3.3 EEPROM Mode

The HMC7545AxLP47 EVB Graphical User Interface (GUI) is also used to update/optimize register values for EQ and DE in EEPROM mode. The EEPROM will operate as I2C Slave and the HMC7545AxLP47 will operate as I2C Master in EEPROM Mode. EEPROM programming can be done with or without the HMC7545 DUT present on the board.

The eval board contains a PCA24S08A, 1024 × 8-bit CMOS EEPROM, with access protection. The EEPROM memory addressing is shown in [Figure 4](#). The target settings for the HMC7545 in master mode must be programmed in the right sequence starting at byte 0. RESETB must be toggled after VCC is stable from LO to HI in order to load EEPROM.

Both the DUT and the EEPROM are connected to the I2C bus. The user must be careful to avoid contention on the bus when the signal conditioner is present. This is usually resolved by the correct addressing (chip address selection) for each part.

There are two banks of jumpers on the HMC7545AxLP47 EVB. Each bank has six signals that can be set to 1 = VCC, 0 = GND, or X = MID-LEVEL via jumpers. The jumpers are shown in the EVB photo provided in [Figure 3](#). The signals and nominal jumper settings are provided in [Tables 10 and 11](#), below.

Table 10: EEPROM Mode: Jumper Bank 1

| Signal Name | Signal Description | EEPROM Mode Settings |
|-------------|--|----------------------|
| SQUELCH | SQUELCH all outputs. Active HI | 0 = GND |
| RESETB | Global RESET. Active LO | 1 = VCC |
| I2C_MAS/SLV | I2C Master Mode, or Slave Mode Select. Master = HI, Slave = LO | 1 = VCC |
| I2CSEL | Parallel Mode (LO) or normal I2C Mode (HI) Select | 1 = VCC |
| SCK | Clock pin for the 2 wire interface | X = MID-LEVEL |
| SDA | Data pin for the 2 wire interface | X = MID-LEVEL |

Table 11: EEPROM Mode: Jumper Bank 2

| Signal Name | Signal Description | EEPROM Mode Settings |
|-------------|---|----------------------|
| RX_EQ0 | LSB of the CTLE settings while in parallel mode | X = MID-LEVEL |
| RX_EQ1 | MSB of the CTLE settings while in parallel mode | X = MID-LEVEL |
| MODE | Selects high or low speed operation: Low Speed = LO, High Speed = HI | 1 = VCC |
| TX_EQ0 | Dual purpose: - Set the chip address in I2C Mode. - LSB of De-Emphasis settings in Parallel Mode | X = MID-LEVEL |
| TX_EQ1 | Dual purpose: - Set the chip address in I2C Mode. - MSB of De-Emphasis settings in Parallel Mode | 0 = GND |
| TXDOUT | Dual purpose: - Set the chip address in I2C Mode. - Set the amplitude in parallel mode | 0 = GND |

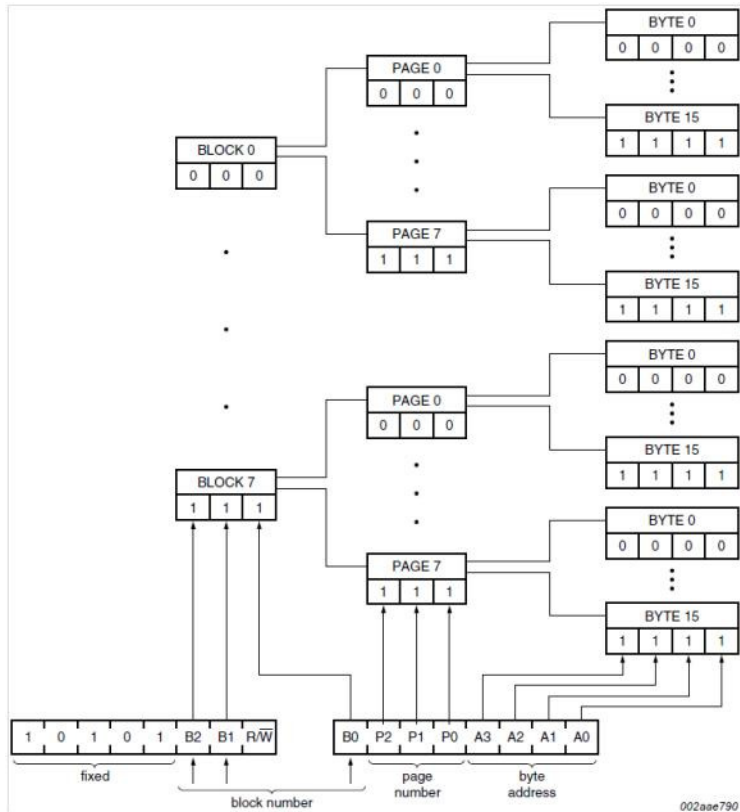

Figure 4. EEPROM Memory Addressing Diagram

4 HMC7545AxLP47 EVB Test Equipment Configuration

The test equipment requirements, and setup configuration are shown below in Figures 5 and 6.

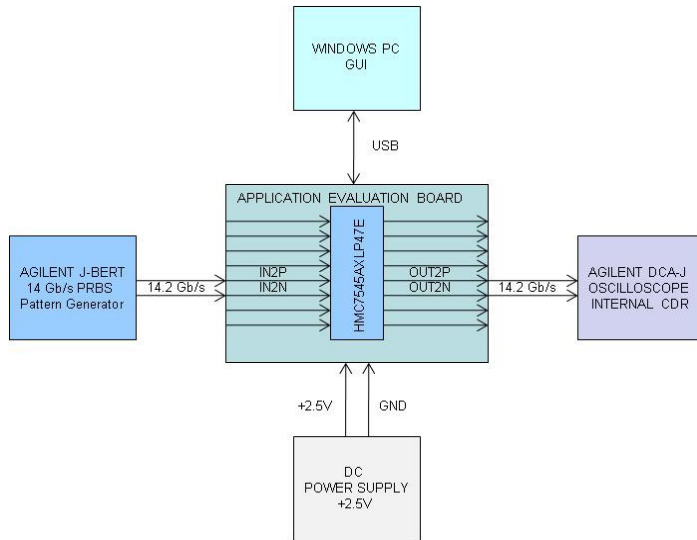

Figure 5. HMC7545AxLP47 EVB Test Equipment Setup: Block Diagram

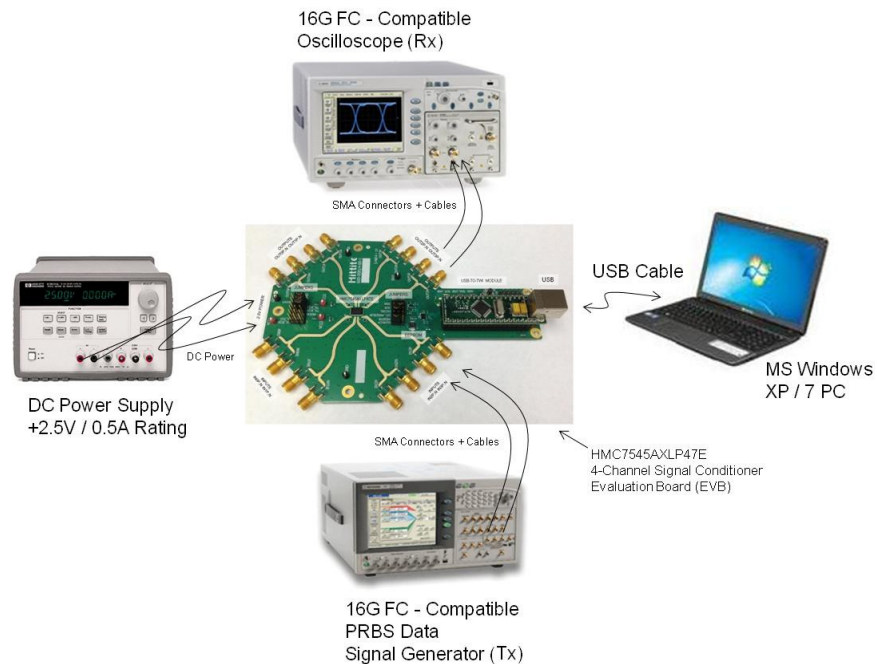

Figure 6. HMC7545AxLP47 EVB Test Equipment Setup: Physical Diagram

5 HMC7545AxLP47 EVB Operating Instructions

5.1 Parallel Mode. HMC7545AxLP47 EVB Operating Instructions

- 1) Configure the DUT using jumpers per Tables 2 and 3, as described in section 3.1, Parallel Mode Operaton.
- 2) Connect +2.5V/GND(0V) power supply to the EVB using the clips on the connection points as shown in EVB Figure 3.
- 3) Connect the USB cable from the PC to the USB port on the USB-to-I2C interface module located on the EVB, as shown in Figure 3. This step is optional in Parallel Mode.
- 4) Turn on +2.5V/0V power supply. VCC supply current and Vout are approximately 90-130mA, and 330mVppd, respectively, using default conditions in Parallel Mode.
- 5) Adjust EQ + DE settings by changing the jumper settings to obtain optimized data eye at output. Use Tables 4 and 5 as a guide.

5.2 I2C Mode Operation

5.2.1 HMC7545AxLP47 EVB Graphical User Interface (GUI) Installation Instructions

Use the Installation CD supplied with the Installation Kit to install the GUI on your PC. MS Win.XP, or 7 OS is recommended.

Insert the CD into your PC CD Drive. This will run the setup.exe installer. Progress through the popup menus and prompts, and click Finish when complete.

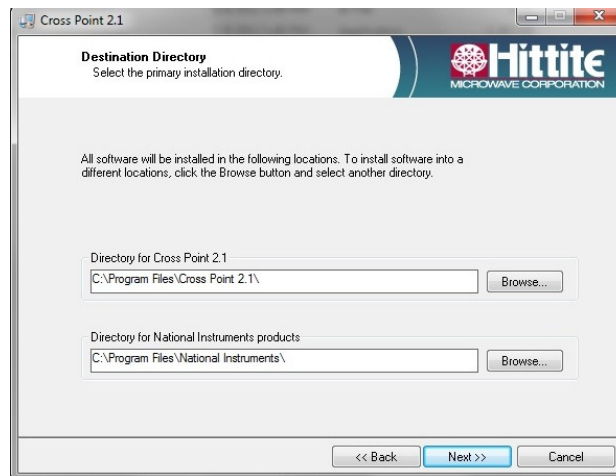

Figure 7: GUI Installer Pop Up Menu #1



Figure 8: GUI Installer Pop Up Menu #2

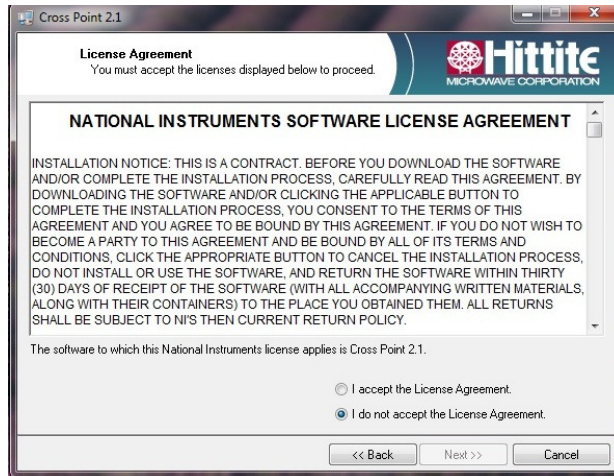

Figure 9: GUI Installer Pop Up Menu #3

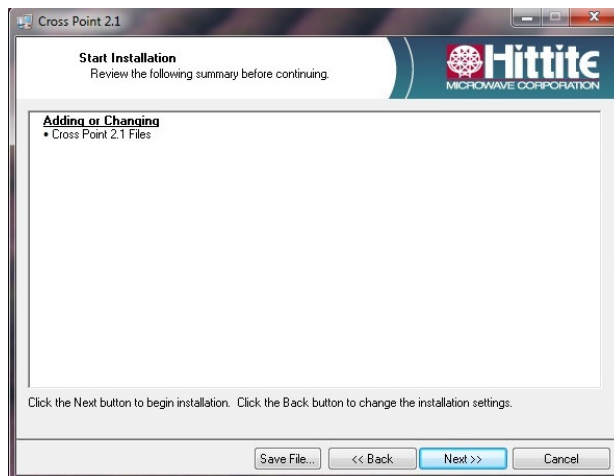

Figure 10: GUI Installer Pop Up Menu #4

5.2.2 HMC7545AxLP47 EVB GUI Operating Instructions

After installation of the GUI on your PC is complete, the GUI will be ready to operate after connecting the USB interface cable and +2.5V power supply to the EVB.

- 1) Configure the DUT using jumpers per Tables 6 and 7, as described in section 3.2, I2C Mode Operaton.
- 2) Connect +2.5V/GND(0V) power supply to the EVB using the clips on the connection points as shown in EVB [Figure 3](#).
- 3) Connect the USB cable from the PC to the USB port on the USB-to-I2C interface module located on the EVB, as shown in [Figure 3](#).
- 4) Turn on +2.5V/0V power supply. Power supply current range is 90mA to 130mA under typical operating conditions.
- 5) Run GUI software program to configure the HMC7545AxLP47 4-Channel Signal Conditioner for operation. The GUI will automatically connect to the EVB via the I2C-to-USB interface. Once connected, the display in the upper right of the GUI will change to from red to green, and the text will change to *Connected*.

The electrical configuration for the HMC7545AxLP47 EVB is controlled via the Graphical User Interface (GUI). The GUI consists of a single tab / page. There are two separate GUI pages, one for HMC7545ABLP47 2-Tap FIR Tx and one for HMC7545AALP47 3-Tap FIR Tx. The different pages are auto selected by the chip address which is different between the two design versions.

Any, or all of the HMC7545AxLP47 channels 0-3 may be used for evaluation.

Please see HMC7545AxLP47 Register Map for detailed register information.

- 6) Verify that the +2.5V Power Supply Current is within the ranges as per Table 12, below.
- 7) GUI Settings: The default Registers/Functions settings are initially loaded into the HMC7545AxLP47 as a starting point for Input EQ and Output DE optimizations. These values are optimized for the back-to-back configuration, which consists of the 1) EVB, 2) SMA cables, and 3) Test Equipment, but no load boards (loss channel). [Tables 8 and 9](#), above, are provided for reference. Please refer to [Table 12](#), and [Figure 11](#), below for the GUI default settings.

Table 12: I2C Mode Register and Parameter Initial Values

| Register/Parameter Name | Register/Parameter Value I2C Mode Default |
|-------------------------|--|
| EQLEVEL | 14 (d) |
| TXMAIN | 9 (d) |
| TXPOST | 4 (d) |
| I(VCC), (mA) | 140 |
| Vout, (mVppd) | 400 |

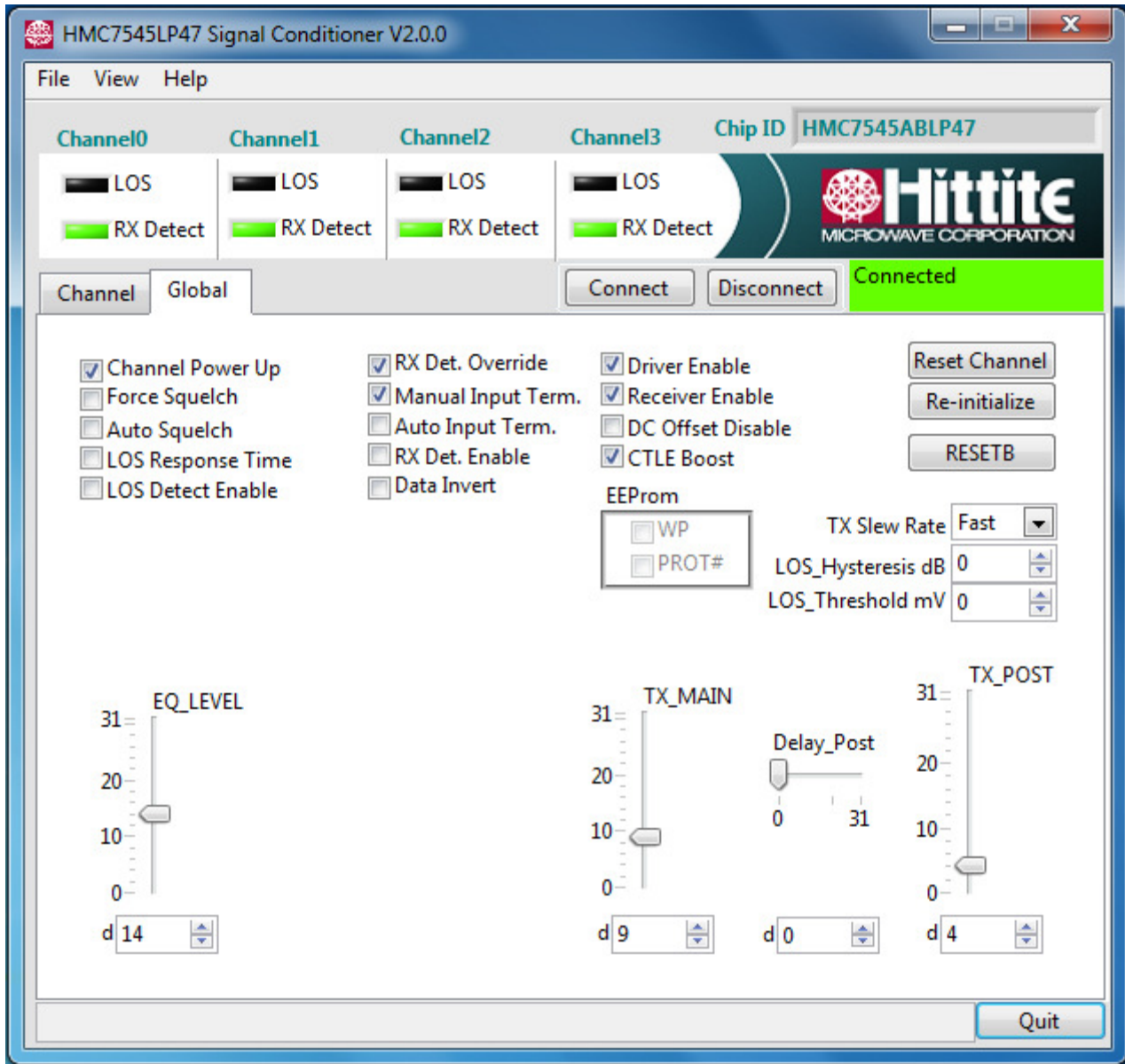

Figure 11a. HMC7545ABLP47 2-Tap FIR Tx EVB GUI Settings for Back-to-Back Configuration

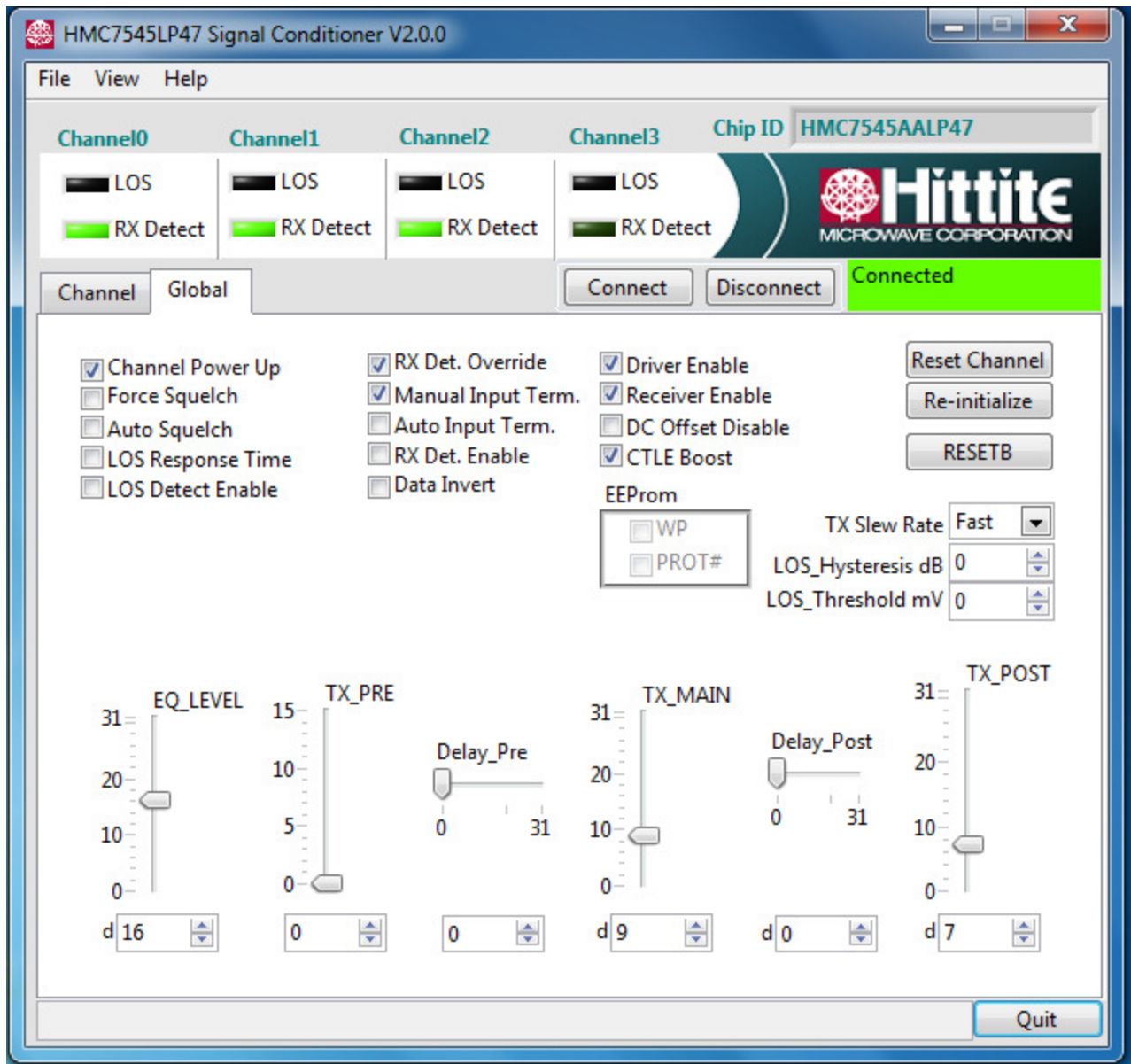

Figure 11b. HMC7545AALP47 3-Tap FIR Tx EVB GUI Settings for Back-to-Back Configuration

5.3 EEPROM Mode. HMC7545AxLP47 EVB Operating Instructions

- 1) Configure the DUT as described in section 2.3, EEPROM Mode Operation.
- 2) Connect +2.5V/GND(0V) power supply to the EVB using the clips on the connection points as shown in EVB [Figure 3](#).
- 3) Connect the USB cable from the PC to the USB port on the USB-to-I2C interface module located on the EVB, as shown in [Figure 3](#).
- 4) Turn on +2.5V/0V power supply. Power supply current range is 80mA to 130mA under typical operating conditions.

- 5) Using the GUI, adjust EQ + DE settings to obtain optimized data eye at output.
- 6) After GUI optimization is complete, Click on “Write to EEPROM” button to update EEPROM memory and save settings.
- 7) Remove USB cable from EVB
- 8) Toggle RESETB after VCC is stable from LO to HI in order to load EEPROM register values to HMC7545AxLP47.

5.4 Basic Test Equipment Configuration and Setup: All Modes

- 1) Refer to [Figures 5 and 6](#) in Section 4, above, for recommended test equipment setup configuration.
- 2) Connect user input signal source (e.g.: PPG) to user-selected input channel(s) via SMA connectors and cables. A transmission line load board that emulates a lossy channel may be inserted between the source and the EVB.
- 3) Connect user measurement equipment (e.g.: oscilloscope) to user-selected output channel(s). A transmission line load that emulates a lossy channel board may be inserted between the EVB and the measurement equipment.
- 4) Turn on the pattern generator signal source.
- 5) Observe output(s) and update/optimize register settings via 1) I2C/GUI Mode, 2) Parallel Mode, or 3) EEPROM Mode settings for Equalization (EQ), and/or De-Emphasis (DE) optimization, as required.

Example HMC7545ABLP47 EVB data eye plots with default GUI settings, $V_{out} \approx 400mV_{ppd}$, and back-to-back configuration (EVB only), are provided, below in [Figures 12a, 13a, and 14a](#).

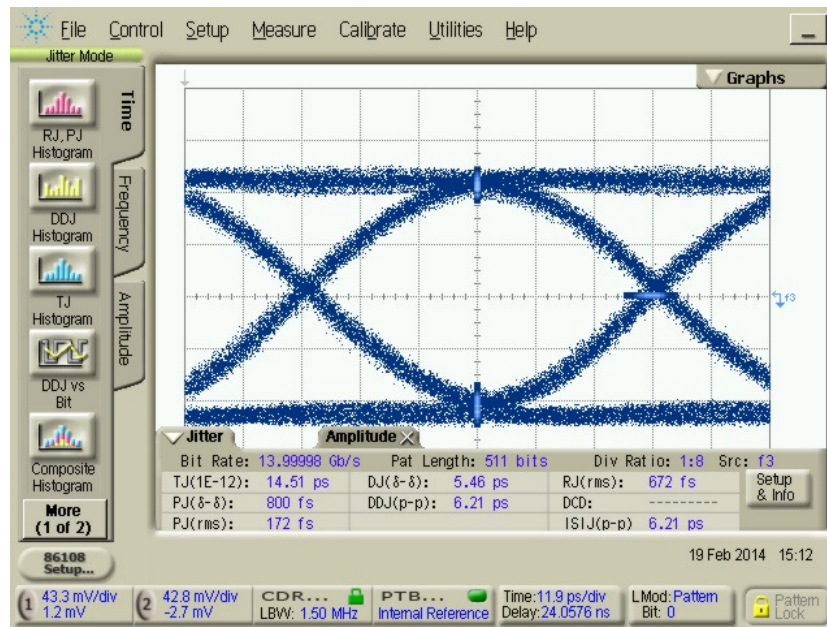

Figure 12a. 14.0 Gbps (16G FC) Data Eye: Default Settings, Back-to-Back Configuration

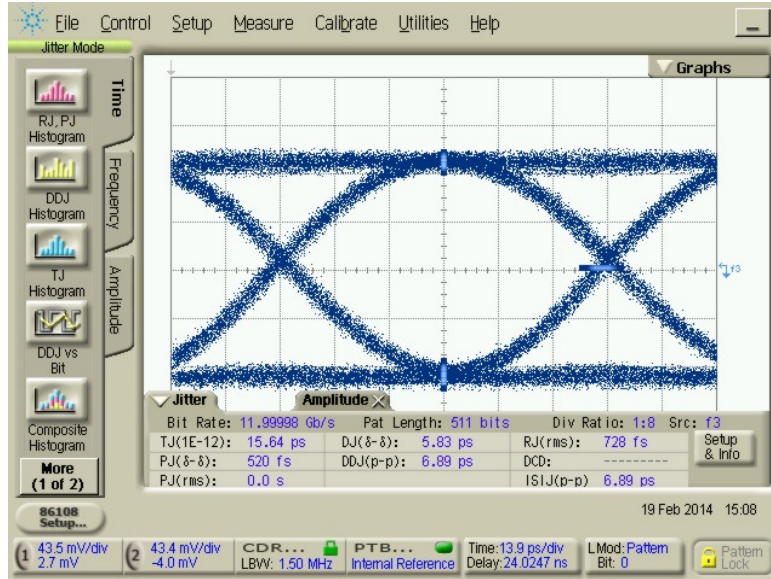

Figure 13a. 12.0 Gbps Data Eye: Default Settings, Back-to-Back Configuration

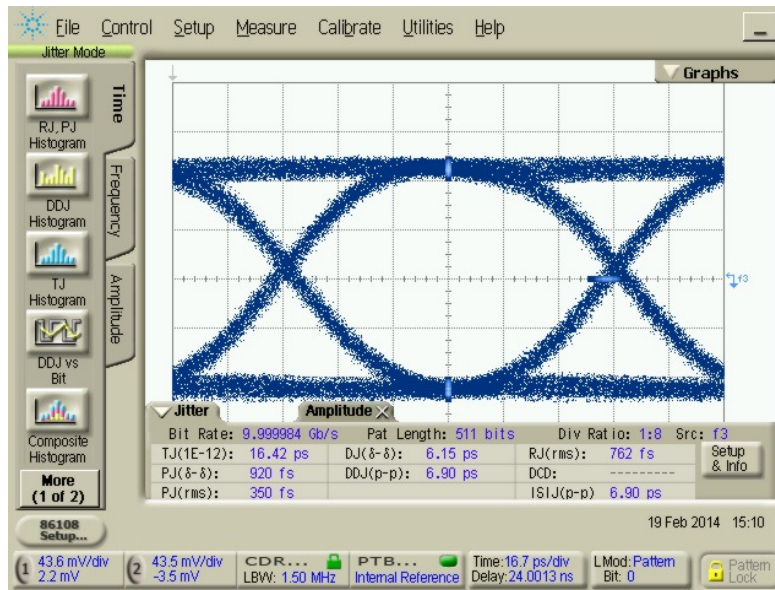

Figure 14a. 10.0 Gbps Data Eye: Default Settings, Back-to-Back Configuration

Example HMC7545AALP47 EVB data eye plots with modified GUI settings, $V_{out} \approx 400mV_{ppd}$, and back-to-back configuration (EVB only), are provided, below in [Figures 12b, 13b, and 14b](#).

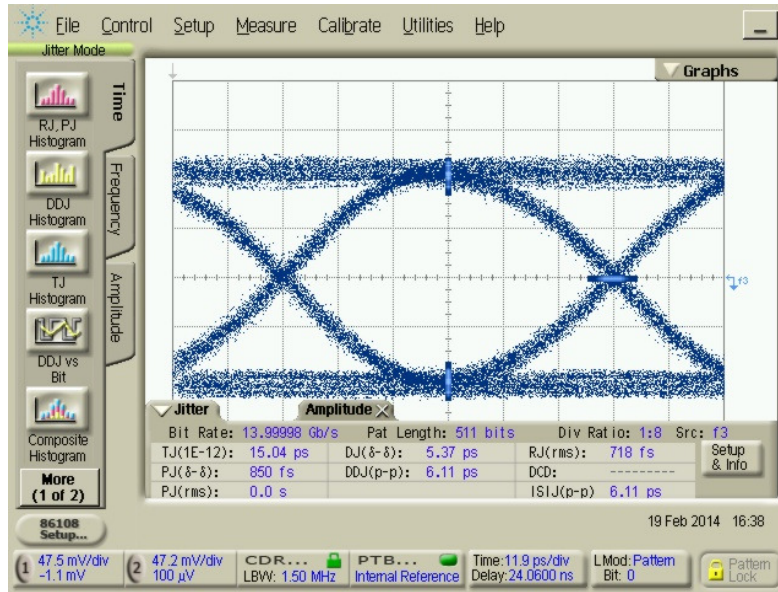

Figure 12b. 14.0 Gbps (16G FC) Data Eye: Default Settings, Back-to-Back Configuration

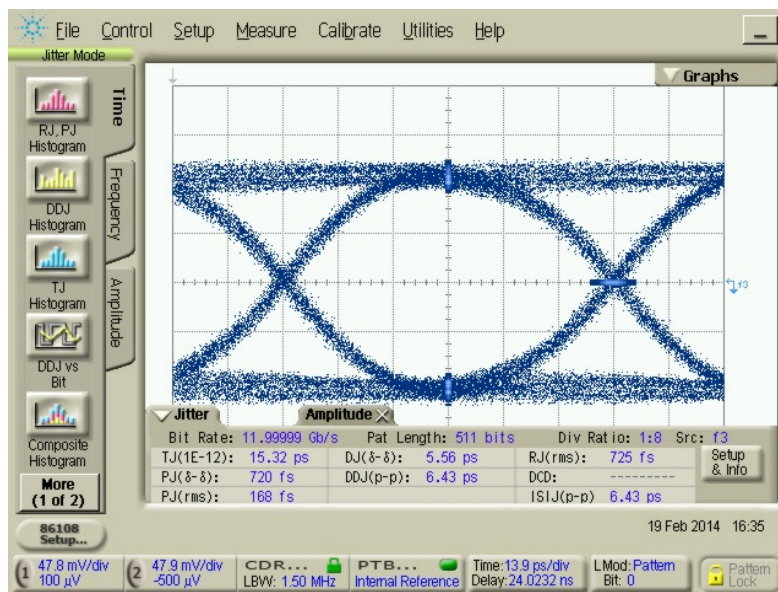

Figure 13b. 12.0 Gbps Data Eye: Default Settings, Back-to-Back Configuration

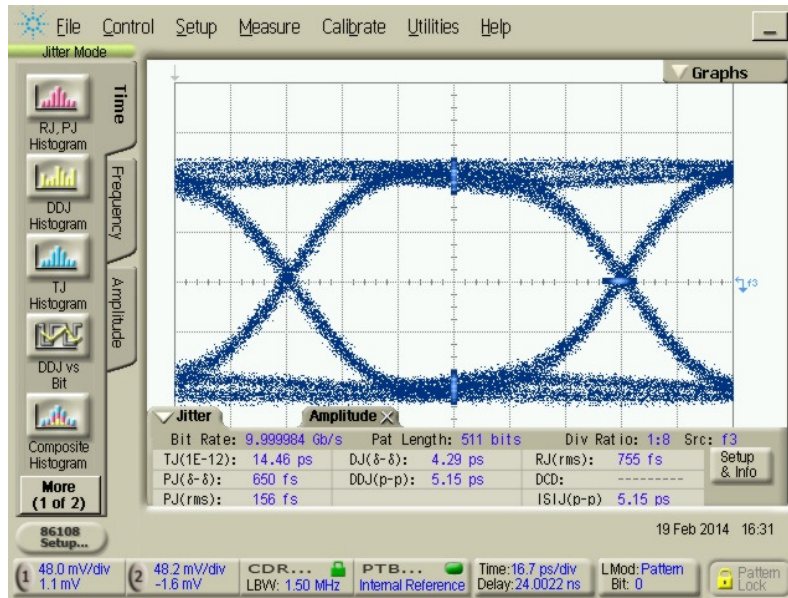

Figure 14b. 10.0 Gbps Data Eye: Default Settings, Back-to-Back Configuration

6 HMC7545AxLP47 EVB Equalization (EQ) and De-Emphasis (DE) Operation

The HMC7545ABLP47 2-Tap FIR Tx is used as the example for this section. The input Rx CTLE EQ range is 18 dB and resolution is 0.75dB, and the output Tx DE range is 12dB and resolution is 0.75dB.

The reference points, as described, below, are given in the block diagram in [Figure 15](#). Note that in addition to the external load board loss, there is approximately -1dB loss for each of four input and four output differential channels on the EVB. This is due to the on-PCB transmission lines, as shown in [Figure 3](#).

Example EQ and DE results are shown in [Figures 16 & 17](#) and [Figures 18 & 19](#), below.

[Figure 16](#) shows a 12.0 Gb/s signal through a 10” load board (lossy channel emulator) only. [Figure 17](#) shows the output after Equalization (EQ) for a 12.0 Gb/s input signal routed through the EVB with a 10” load board lossy channel at the input.

[Figure 18](#) shows a 12.0 Gb/s input signal through a 10” load board (lossy channel emulator) only. [Figure 19](#) shows the HMC7545AxLP47 output after De-Emphasis (DE) for a 12.0 Gb/s input signal routed through the with a 10” load board lossy channel at the output.

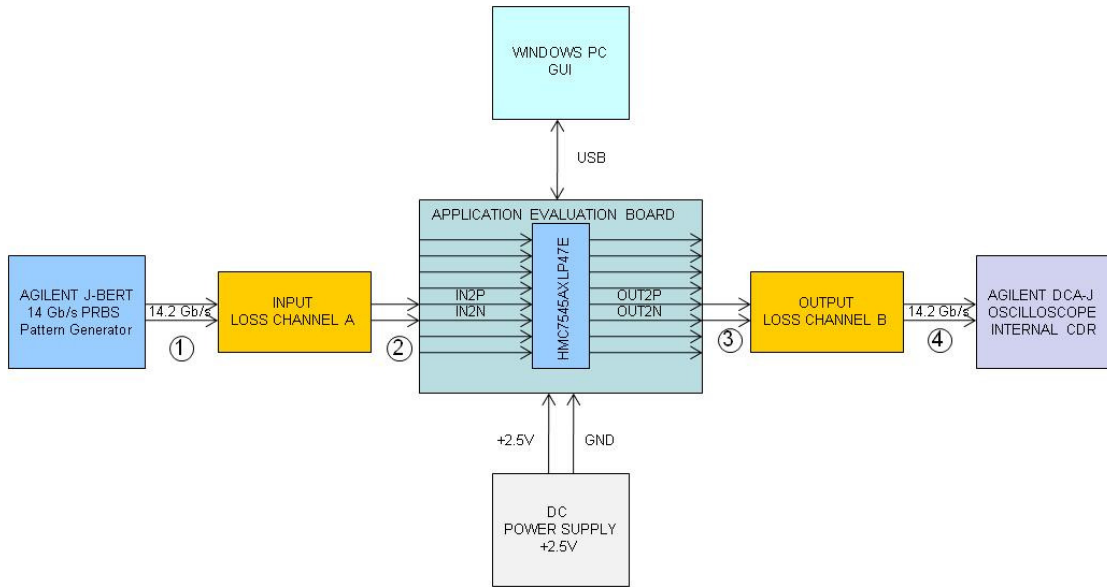

Figure 15. HMC7545AxLP47 Lossy Channel Block Diagram

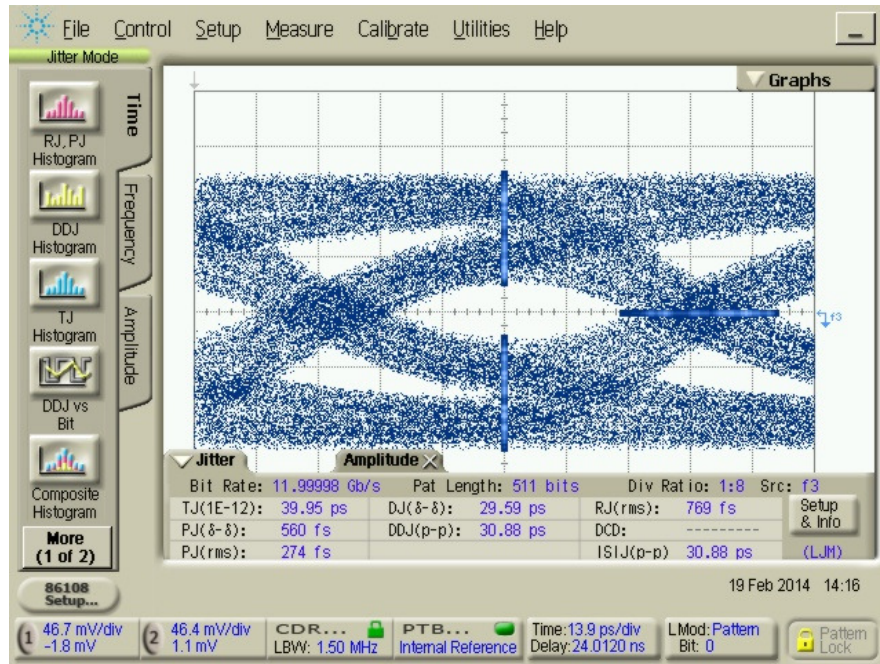

Figure 16. 12.0 Gb/s PRBS 2⁹-1. 10” Load Board Lossy Channel Only, as Indicated by *Point 2* in Figure 15.

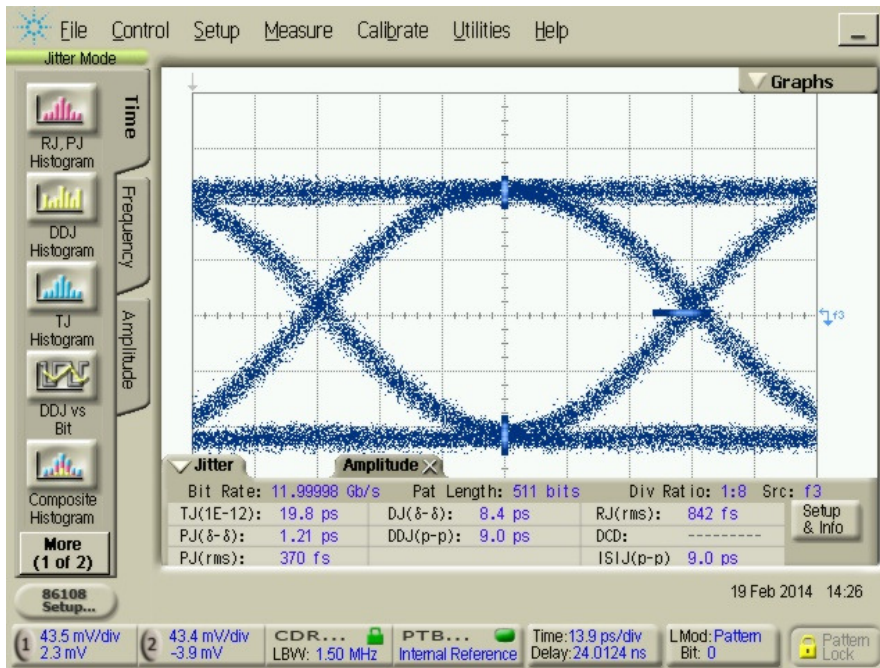

Figure 17. 12.0 Gb/s PRBS 2⁹-1. HMC7545ABLP47 EVB with 10” Load Board Lossy Channel at *Input* Using Equalization (EQ), as Indicated by *Point 3* in Figure 15.

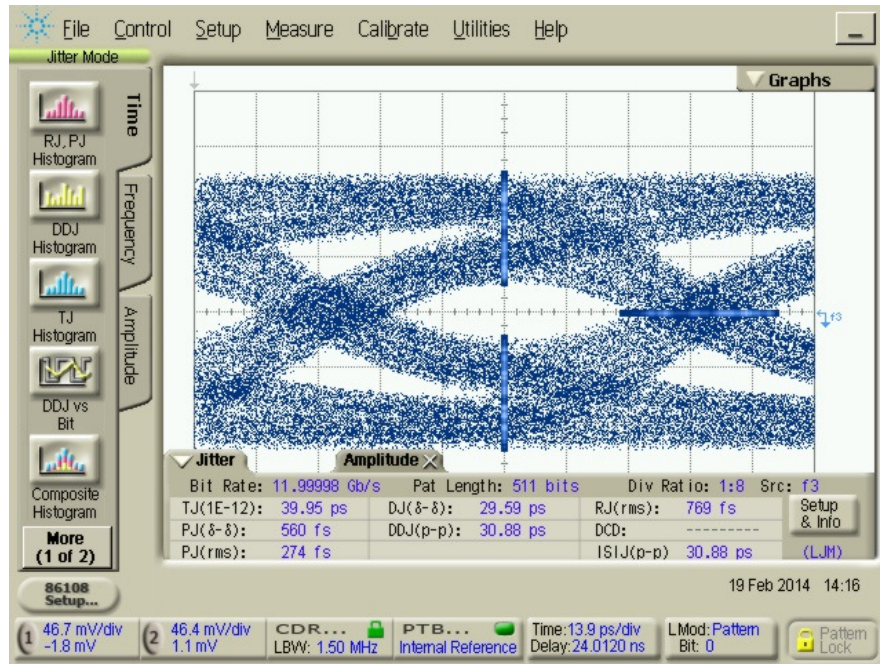

Figure 18. 12.0 Gb/s PRBS 2⁹-1. 10” Load Board Lossy Channel Only, as Indicated by Point 4, with Source at Point 3 in Figure 15.

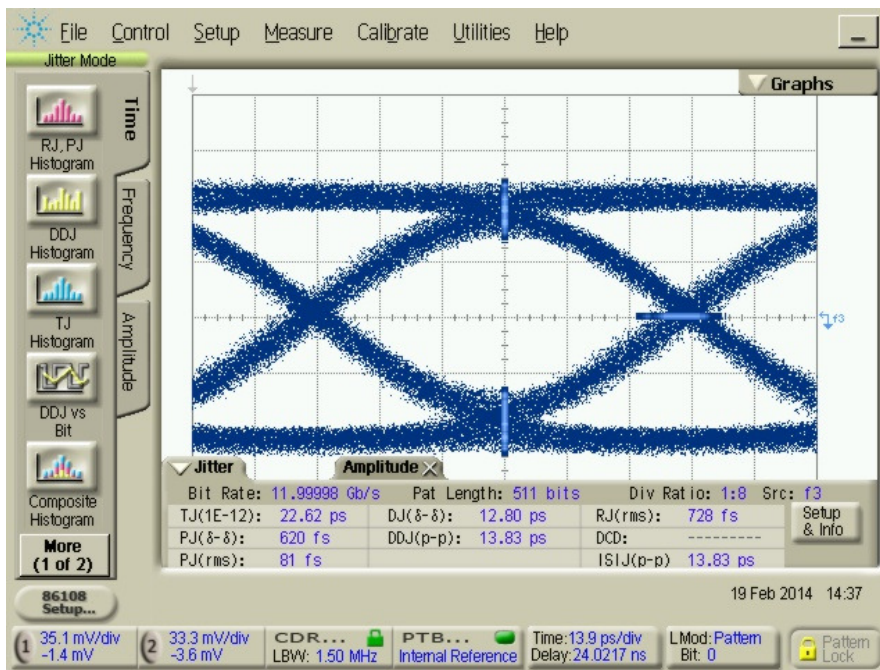

Figure 19. 12.0 Gb/s PRBS 2⁹-1. HMC7545ABLP47 EVB with 10” Load Board Lossy Channel at Output Using 4-Channel Signal Conditioner De-Emphasis (DE), as Indicated by Point 4 in Figure 15.

Looking for pricing, stock, or lifecycle information?

Click below to explore more details on WIN SOURCE:

⊖ [View EV1HMC7545ABLP47 on WIN SOURCE](#)

⊖ [Analog Devices Inc. Information](#)

Optimize Your Supply Chain with WIN SOURCE Solutions

- ✓ Global Sourcing Solution
- ✓ Obsolete Management
- ✓ Cost Control Management
- ✓ Shortage Management
- ✓ Alternative Solution
- ✓ Excess Inventory Management