



**THE DATASHEET OF
FH23-39S-0.3SHW(10)**



0.3mm Contact Pitch, 1.25mm above the board, Flexible Printed Circuit Connectors

FH 23 Series

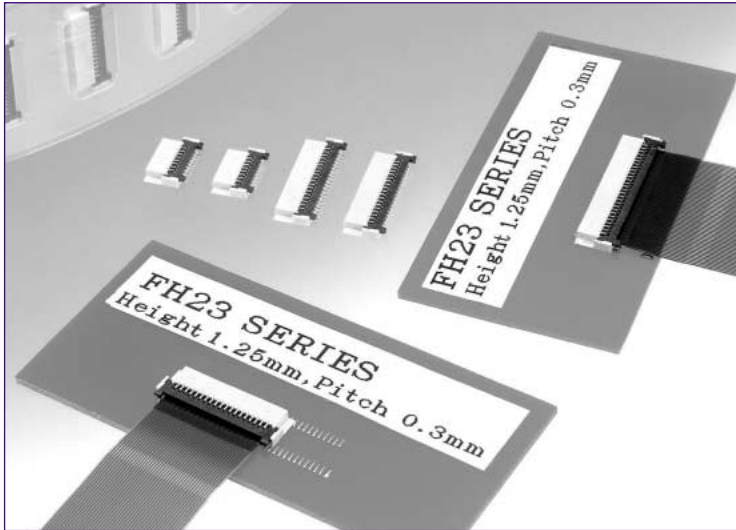

● Staggered termination configuration. Only 1.25 mm above the board.

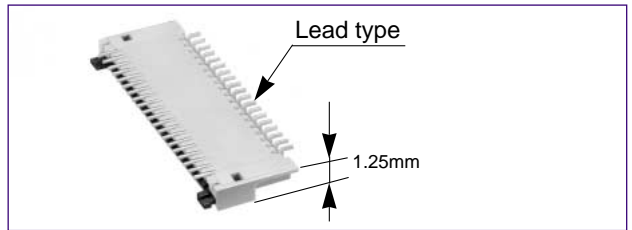
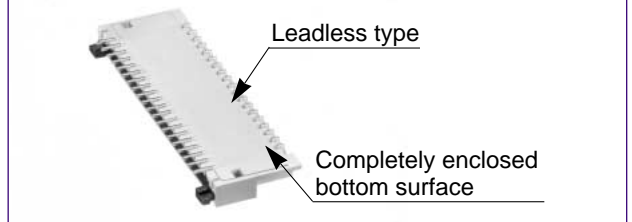

Features

1. FPC low insertion force and high holding force

Hirose Electric's unique low insertion force (LIF) design (patents pending) improves the Flexible Printed Circuit (FPC) holding force after insertion.

FPC insertion force: Reduced approximately 36% (as compared with FH18 Series connectors).

FPC holding force: Improvement of approximately 22% (as compared with FH18 Series connectors).

2. Temporary hold of FPC

There is no need to hold the FPC after insertion in the connector. The connector will hold it in correct position, allowing closing of the actuator.

3. Easy board mounting

The surface mounted termination of the contacts is staggered on 0.6 mm centers, positioned on front and back of the connector.

Bottom of the connector is completely insulated, allowing conductive traces on PCB to run under the connector.

4. Proven Flip-lock Actuator assures easy and reliable operation

Rotating actuator permits easy insertion and reliable connection with the FPC. Tactile sensation confirms complete mechanical locking of the actuator and the electrical connection.

5. Variations to suit different mounting areas

Available with lead and leadless type of terminations (for opposing FPC insertion side).

6. Designed for placement with automatic equipment

Flat top surface allows pick-up with vacuum nozzles.

Packaged in embossed tape, on reel. One reel contains 2,500 pieces.

7. Accepts 0.2mm thick FPC

8. Variety of contact positions

Available with 15, 17, 21, 25, 27, 31, 33, 39, 45, 51 and 61 pos.

8. Environmental considerations

Plating is lead-free in order to protect environment.

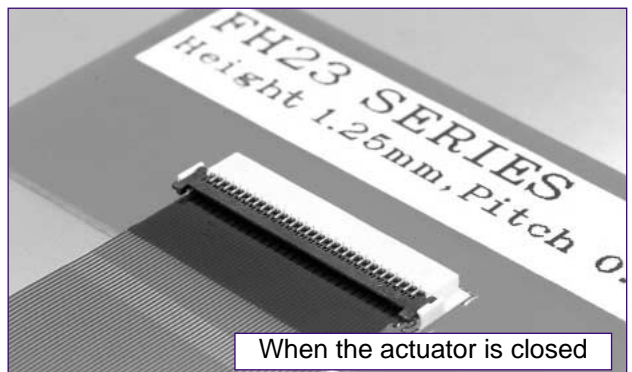
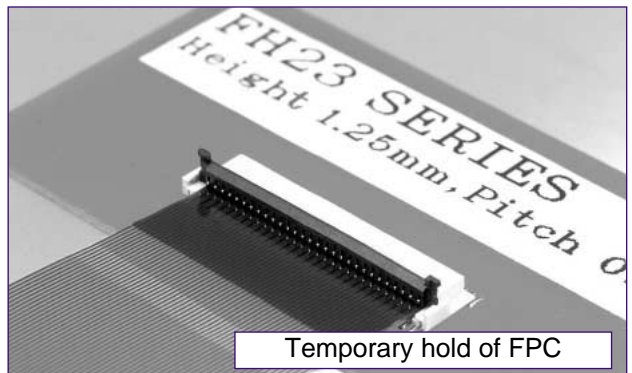
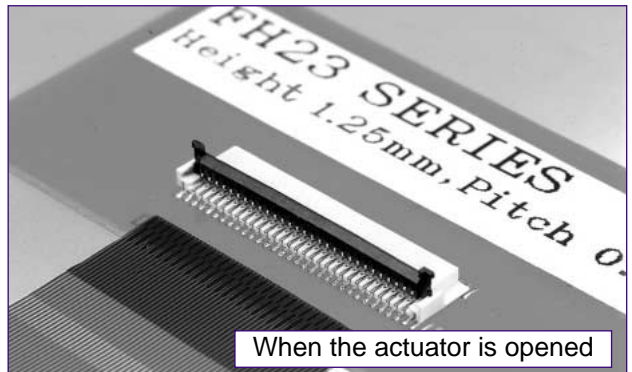

Applications

Mobile phones, PDA's, digital cameras, digital video cameras and other compact devices requiring interconnections of the main circuit with the LCD, plasma display (PDP), camera module, or other devices.

Product Specifications

| | | | | |
|---------|----------------|----------|--|--|
| Ratings | Current rating | 0.3 A DC | Operating temperature range -55 °C to +85 °C (Note 1) | Storage temperature range -10 °C to +50 °C (Note 2) |
| | Voltage rating | 50 V AC | Operating humidity range Relative humidity 90% max. (No condensation) | Storage humidity range Relative humidity 90% max. |

| | |
|-----------------|--|
| Recommended FPC | Thickness: = 0.2±0.03mm tinned copper or pure tin plating (Note 3) |
|-----------------|--|

| Item | Specification | Conditions |
|--|---|---|
| 1. Insulation resistance | 50 M ohms min. | 100 V DC |
| 2. Withstanding voltage | No flashover or insulation breakdown | 90 V AC/1 minute |
| 3. Contact resistance | 100 m ohms max. *Including FPC/FFC conductor resistance | 1 mA AC |
| 4. Durability (insertion/ withdrawal) | Contact resistance: 100 m ohms max. No damage, cracks, or parts dislocation. | 10 cycles |
| 5. Vibration | No electrical discontinuity of 1 μs or more. Contact resistance: 100 m ohms max. No damage, cracks, or parts dislocation. | Frequency: 10 to 55 Hz, single amplitude of 0.75 mm, 2 hours in each of the 3 directions |
| 6. Shock | No electrical discontinuity of 1 μs. min. Contact resistance: 100 m ohms max. No damage, cracks, or parts dislocation. | Acceleration of 981 m/s ² , 6ms duration, sine half-wave waveform, 3 cycles in each of the 3 axis. |
| 7. Humidity (Steady state) | Contact resistance: 100 m ohms max. Insulation resistance: 100 M ohms min. No damage, cracks, or parts dislocation. | 96 hours at temperature of 40°C and humidity of 90% to 95% |
| 8. Temperature cycle | Contact resistance: 100 m ohms max. Insulation resistance: 100 M ohms min. No damage, cracks, or parts looseness. | Temperature: -55°C → +15°C to +35°C → +85°C → +15°C to +35°C Time: 30 → 2 to 3 → 30 → 2 to 3 (Minutes) 5 cycles |
| 9. Resistance to soldering heat | No deformation of components affecting performance. | Reflow: At the recommended temperature profile Manual soldering: 350 °C ± 5 °C for 5 seconds |

Note 1: Includes temperature rise caused by current flow.

Note 2: The term "storage" refers to products stored for long period of time prior to mounting and use. Operating Temperature Range and Humidity range covers non- conducting condition of installed connectors in storage, shipment or during transportation.

Note 3: When FPC is gold plated, the connector contacts should be also gold plated: Select the (05) specification.

Materials

| Part | Material | Finish | Remarks |
|-----------|-----------------|---------------------------|---------|
| Insulator | LCP | Color:Beige | UL94V-0 |
| | LCP | Color:Black | |
| Contacts | Phosphor bronze | Pure tin plating (Note 3) | _____ |

Ordering information

FH23 - 39S - 0.3 SHW (05)

① ② ③ ④ ⑤

| | |
|---|---|
| ① Series name : FH23 | ④ Terminal type SHW: SMT horizontal mounting type, lead type termination. SHAW: SMT horizontal mounting type, lead-less type termination. |
| ② No. of contacts. Number of contacts : 15,17,21,25,27,31,33,39,45,51,61 | ⑤ Plating specifications : Blank : Tin plating (05) : Gold plating |
| ③ Contact pitch: 0.3 mm | |

◆ Connector Dimensions (Lead Type termination)

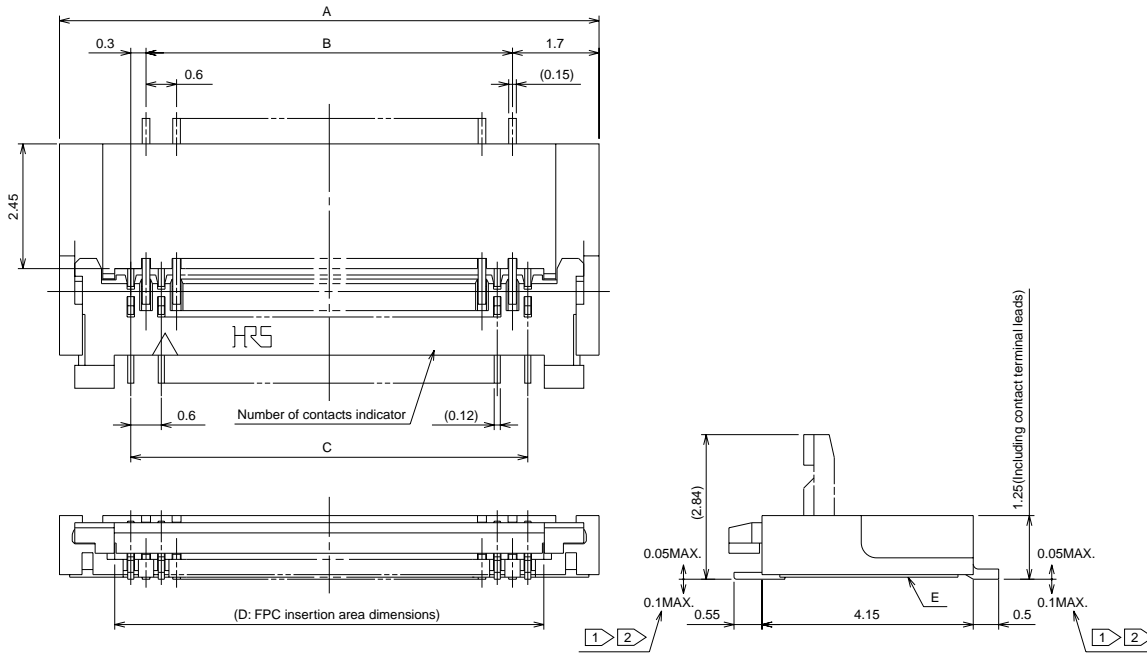

- Notes
- ① The coplanarity of each terminal lead is within 0.1.
 - ② The contact terminal lead position indicates the dimension from the E surface, the bottom surface of the insulator body.
 - 3 Any discoloration of the plastic compound will NOT AFFECT form, fit or function of the connector.

Lead Type

Unit: mm

| Part Number | CL No. | Number of Contacts | A | B | C | D |
|-----------------|------------|--------------------|------|------|------|-------|
| FH23-15S-0.3SHW | 586-1317-0 | 15 | 7 | 3.6 | 4.2 | 4.83 |
| FH23-17S-0.3SHW | 586-1300-7 | 17 | 7.6 | 4.2 | 4.8 | 5.43 |
| FH23-21S-0.3SHW | 586-1314-1 | 21 | 8.8 | 5.4 | 6 | 6.63 |
| FH23-25S-0.3SHW | 586-1322-0 | 25 | 10 | 6.6 | 7.2 | 7.83 |
| FH23-27S-0.3SHW | 586-1308-9 | 27 | 10.6 | 7.2 | 7.8 | 8.43 |
| FH23-31S-0.3SHW | 586-1302-2 | 31 | 11.8 | 8.4 | 9 | 9.63 |
| FH23-33S-0.3SHW | 586-1304-8 | 33 | 12.4 | 9 | 9.6 | 10.23 |
| FH23-39S-0.3SHW | 586-1306-3 | 39 | 14.2 | 10.8 | 11.4 | 12.03 |
| FH23-45S-0.3SHW | 586-1318-2 | 45 | 16 | 12.6 | 13.2 | 13.83 |
| FH23-51S-0.3SHW | 586-1312-6 | 51 | 17.8 | 14.4 | 15 | 15.63 |
| FH23-61S-0.3SHW | 586-1310-0 | 61 | 20.8 | 17.4 | 18 | 18.63 |

Note: Embossed tape reel packaging(2,500 pieces/reel)
Please order by number of reels.

■ Connector Dimensions Diagram (Leadless Type termination)

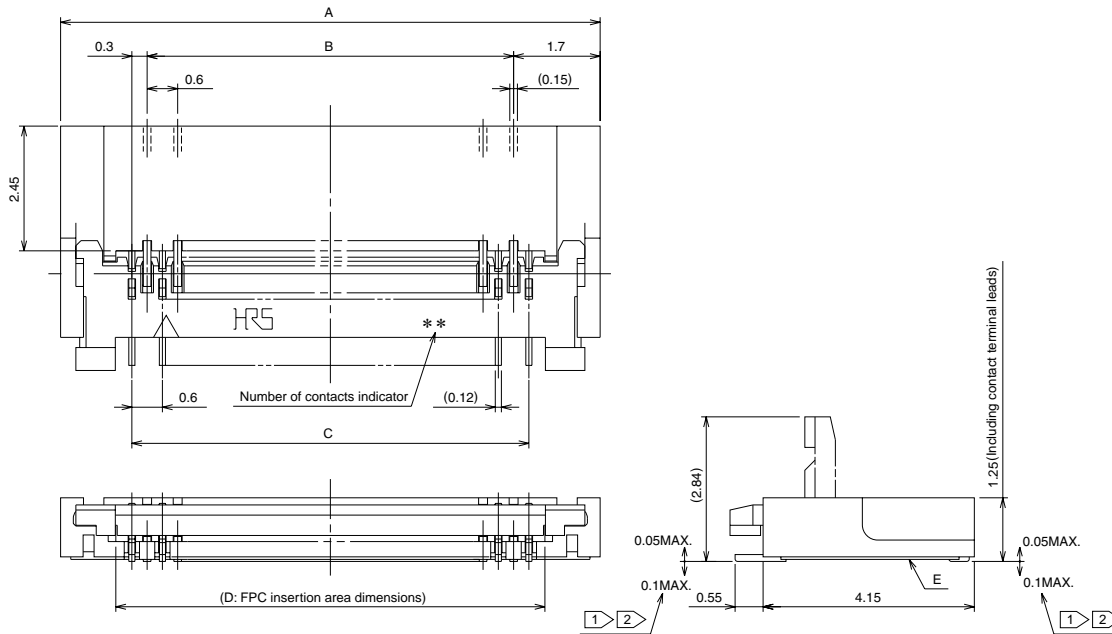

- Notes
- ① The coplanarity of each terminal lead is within 0.1.
 - ② The contact terminal lead position indicates the dimension from the E surface, the bottom surface of the insulator body.
 - ③ Any discoloration of the plastic compound will NOT AFFECT form, fit or function of the connector.

Leadless Type

Unit: mm

| Part Number | CL No. | Number of Contacts | A | B | C | D |
|------------------|------------|--------------------|------|------|------|-------|
| FH23-15S-0.3SHAW | 586-1316-7 | 15 | 7 | 3.6 | 4.2 | 4.83 |
| FH23-17S-0.3SHAW | 586-1301-0 | 17 | 7.6 | 4.2 | 4.8 | 5.43 |
| FH23-21S-0.3SHAW | 586-1315-4 | 21 | 8.8 | 5.4 | 6 | 6.63 |
| FH23-25S-0.3SHAW | 586-1323-2 | 25 | 10 | 6.6 | 7.2 | 7.83 |
| FH23-27S-0.3SHAW | 586-1309-1 | 27 | 10.6 | 7.2 | 7.8 | 8.43 |
| FH23-31S-0.3SHAW | 586-1303-5 | 31 | 11.8 | 8.4 | 9 | 9.63 |
| FH23-33S-0.3SHAW | 586-1305-0 | 33 | 12.4 | 9 | 9.6 | 10.23 |
| FH23-39S-0.3SHAW | 586-1307-6 | 39 | 14.2 | 10.8 | 11.4 | 12.03 |
| FH23-45S-0.3SHAW | 586-1319-5 | 45 | 16 | 12.6 | 13.2 | 13.83 |
| FH23-51S-0.3SHAW | 586-1313-9 | 51 | 17.8 | 14.4 | 15 | 15.63 |
| FH23-61S-0.3SHAW | 586-1311-3 | 61 | 20.8 | 17.4 | 18 | 18.63 |

Note: Embossed tape reel packaging(2,500 pieces/reel)
Please order by number of reels.

◆ Recommended PCB Land and Metal Mask Dimensions (Lead Type)

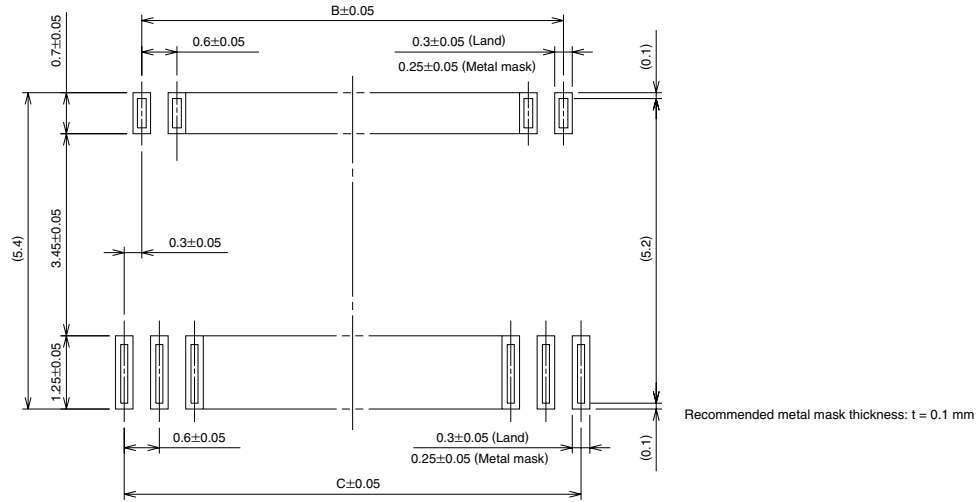

Lead Type

Unit: mm

| Part Number | CL No. | Number of Contacts | B | C | G |
|-----------------|------------|--------------------|------|------|------|
| FH23-15S-0.3SHW | 586-1317-0 | 15 | 3.6 | 4.2 | 4.8 |
| FH23-17S-0.3SHW | 586-1300-7 | 17 | 4.2 | 4.8 | 5.4 |
| FH23-21S-0.3SHW | 586-1314-1 | 21 | 5.4 | 6 | 6.6 |
| FH23-25S-0.3SHW | 586-1322-0 | 25 | 6.6 | 7.2 | 7.8 |
| FH23-27S-0.3SHW | 586-1308-9 | 27 | 7.2 | 7.8 | 8.4 |
| FH23-31S-0.3SHW | 586-1302-2 | 31 | 8.4 | 9 | 9.6 |
| FH23-33S-0.3SHW | 586-1304-8 | 33 | 9 | 9.6 | 10.2 |
| FH23-39S-0.3SHW | 586-1306-3 | 39 | 10.8 | 11.4 | 12 |
| FH23-45S-0.3SHW | 586-1318-2 | 45 | 12.6 | 13.2 | 13.8 |
| FH23-51S-0.3SHW | 586-1312-6 | 51 | 14.4 | 15 | 15.6 |
| FH23-61S-0.3SHW | 586-1310-0 | 61 | 17.4 | 18 | 18.6 |

◆ Recommended Land and Metal Mask Dimensions (Leadless Type)

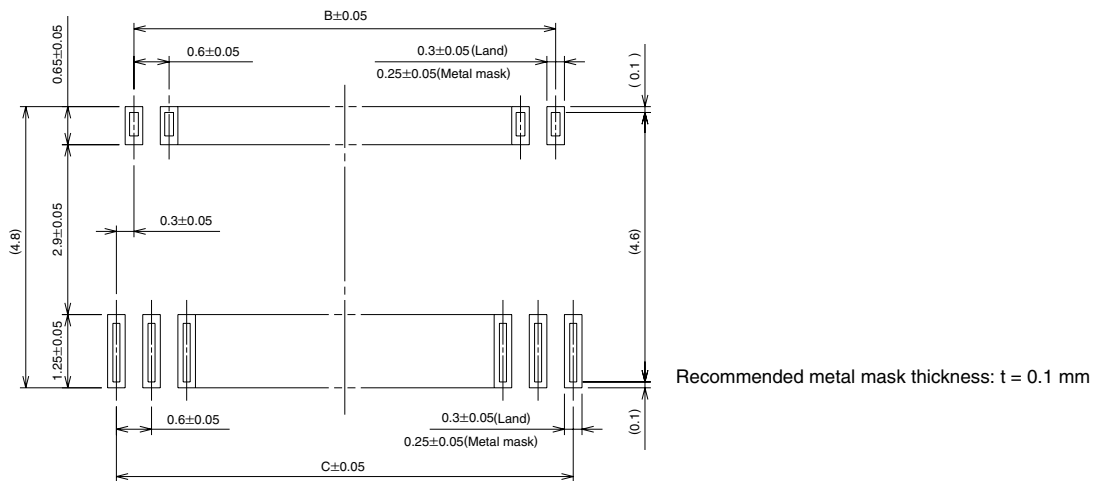

Leadless Type

Unit: mm

| Part Number | CL No. | Number of Contacts | B | C | G |
|------------------|------------|--------------------|------|------|------|
| FH23-15S-0.3SHAW | 586-1316-7 | 15 | 3.6 | 4.2 | 4.8 |
| FH23-17S-0.3SHAW | 586-1301-0 | 17 | 4.2 | 4.8 | 5.4 |
| FH23-21S-0.3SHAW | 586-1315-4 | 21 | 5.4 | 6 | 6.6 |
| FH23-25S-0.3SHAW | 586-1323-2 | 25 | 6.6 | 7.2 | 7.8 |
| FH23-27S-0.3SHAW | 586-1309-1 | 27 | 7.2 | 7.8 | 8.4 |
| FH23-31S-0.3SHAW | 586-1303-5 | 31 | 8.4 | 9 | 9.6 |
| FH23-33S-0.3SHAW | 586-1305-0 | 33 | 9 | 9.6 | 10.2 |
| FH23-39S-0.3SHAW | 586-1307-6 | 39 | 10.8 | 11.4 | 12 |
| FH23-45S-0.3SHAW | 586-1319-5 | 45 | 12.6 | 13.2 | 13.8 |
| FH23-51S-0.3SHAW | 586-1313-9 | 51 | 14.4 | 15 | 15.6 |
| FH23-61S-0.3SHAW | 586-1311-3 | 61 | 17.4 | 18 | 18.6 |

● Embossed Carrier Tape Dimensions (Tape width of 32 mm min.)

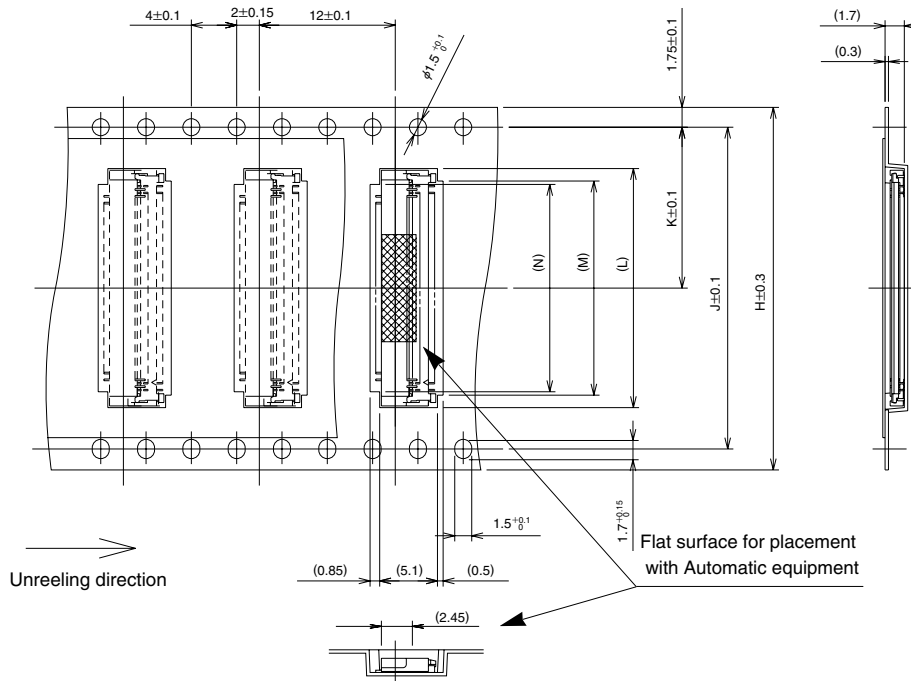

Unit: mm

| Part Number | CL No. | Number of Contacts | H | J | K | L | M | N | Q |
|------------------|------------|--------------------|----|------|------|------|------|------|------|
| FH23-61S-0.3SHW | 586-1310-0 | 61 | 32 | 28.4 | 14.2 | 21.1 | 18.9 | 18.3 | 32.5 |
| FH23-61S-0.3SHAW | 586-1311-3 | | | | | | | | |

● Reel Dimensions

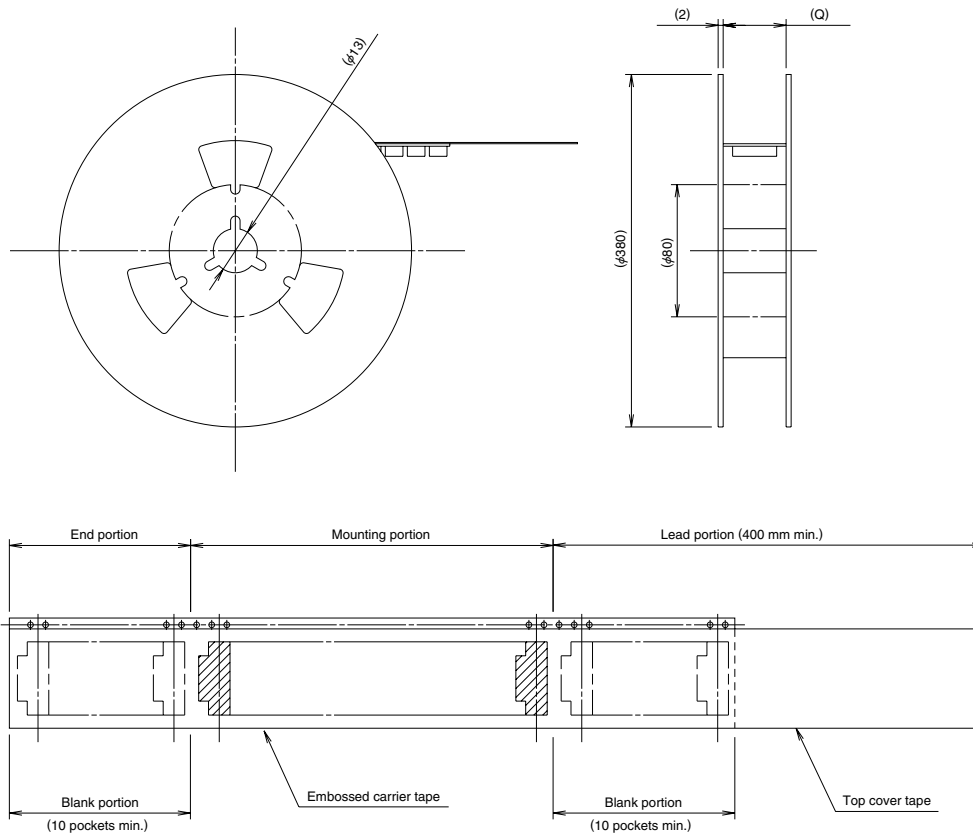

◆ Recommended Temperature Profile

● Using Conventional Solder Paste

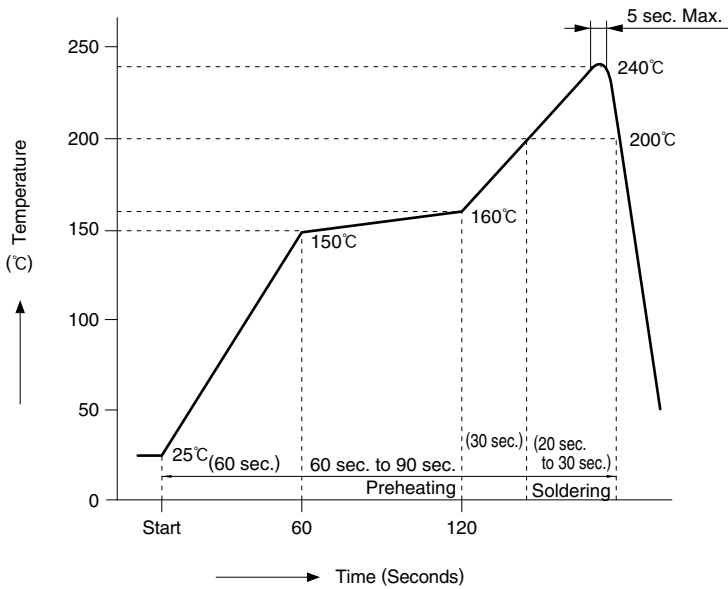

Recommended Conditions

Reflow system : IR reflow
 Solder : Paste type 63 Sn/37 Pb
 (Flux content 11 wt%)
 Test board : Glass epoxy 45mm x 100mm x 1.6mm
 Metal mask thickness : 0.1 mm

Recommended temperature profile.

The temperature may be slightly changed according to the solder paste type and thickness.

● Using Lead-free Solder paste

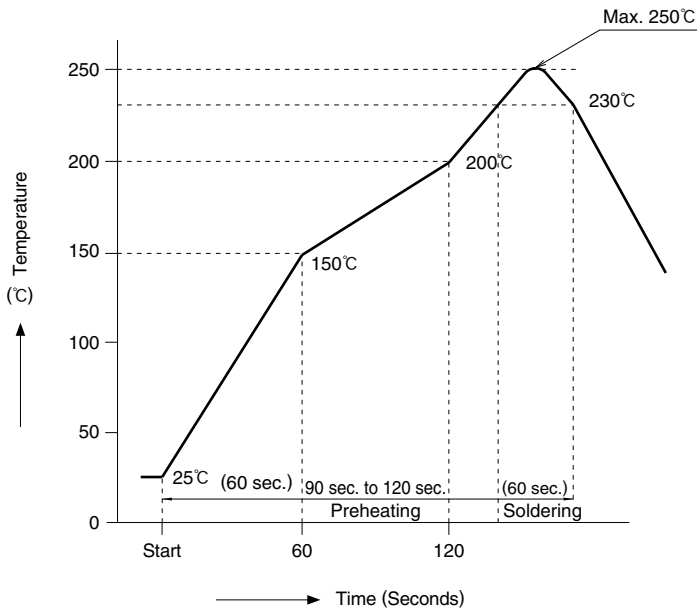

Recommended Conditions

Reflow system : IR reflow
 Solder : Paste type Sn/0.3 Ag/0.5 Cu
 (Flux content 11 wt%)
 Test board : Glass epoxy 45mm x 100mm x 1.6 mm
 Metal mask thickness : 0.1 mm

Recommended temperature profile.

The temperature may be slightly changed according to the solder paste type and thickness.

◆FH23 Series FPC Construction (Recommended Specifications)

1. Using Single-sided FPC

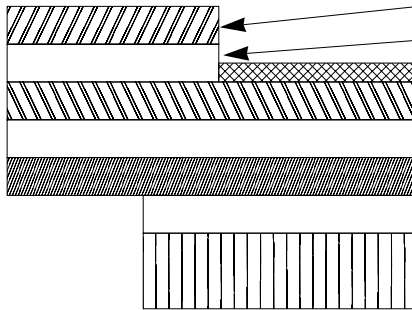

| Material Name | Material | Thickness (μm) |
|---------------------------------|---|----------------|
| Covering film layer. | Polyamide 1 mil thick. | 25 |
| Cover adhesive | | 25 |
| Surface treatment | Tinned copper plating or pure tin plating | 5 |
| Copper foil | Cu 1oz | 35 |
| Base adhesive | | 25 |
| Base film | Polyamide 1 mil thick | 25 |
| Reinforcement material adhesive | Heat-hardened adhesive | 30 |
| Stiffener | Polyamide 3 mil thick | 75 |
| Total | | 195 |

2. Using Double-sided FPC

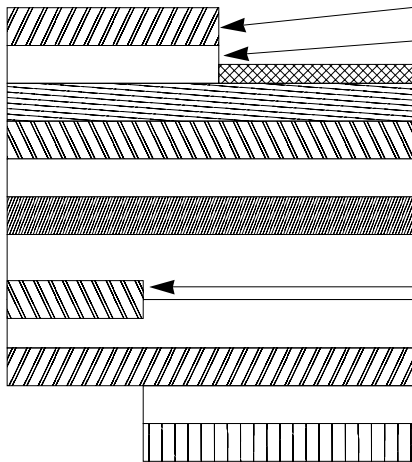

| Material Name | Material | Thickness (μm) |
|---------------------------------|---|----------------|
| Covering layer film | Polyamide 1 mil thick | 25 |
| Cover adhesive | | 25 |
| Surface treatment | Tinned copper plating or pure tin plating | 5 |
| Through-hole copper | Cu | 15 |
| Copper foil | Cu 1/2oz | 18 |
| Base adhesive | | 18 |
| Base film | Polyamide 1 mil thick | 25 |
| Base adhesive | | 18 |
| Copper foil | Cu 1/2oz | 18 |
| Cover adhesive | | 25 |
| Covering layer film | Polyamide 1 mil thick | 25 |
| Reinforcement material adhesive | Heat-hardened adhesive | 25 |
| Stiffener | Polyamide 1 mil thick | 25 |
| Total | | 199 |

3. Precautions

Note : Recommended specification for FPC 0.2±0.03 mm thick.

FPC/FFC Manufactures' Contact List

Sumitomo Bakelite Co., Ltd. Flexible Printed Circuit Board Division
5-8, Higashi-shinagawa 2-chome, Shinagawa-ku, Tokyo, Japan

TEL:+81 3 5462 4191
FAX:+81 3 5462 4882

Fujikura Ltd. Electronics Global Marketing Department
1-5-1, Kiba, Koto-ku, Tokyo, Japan

TEL:+81 3 5606 1165
FAX:+81 3 5606 1530

NOK Corporation Sales Division Overseas Business Department
1-12-15, Shiba-Daimon, Minato-ku, Tokyo, Japan

TEL:+81 3 3432 6976/8415
FAX:+81 3 3432 3919

◆ Connector Operation and Precautions

Operation

1. FPC Termination procedure

- 1 Lift up the actuator. Use thumb or index finger.

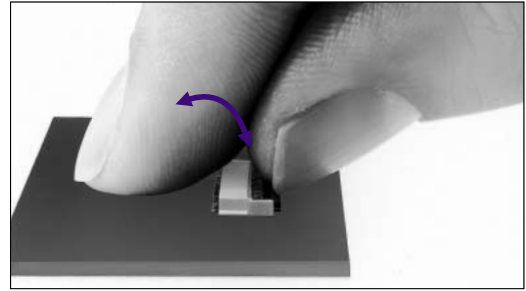

- 2 Insert with the FPC parallel to the mounting surface, with the exposed conductive traces facing down.

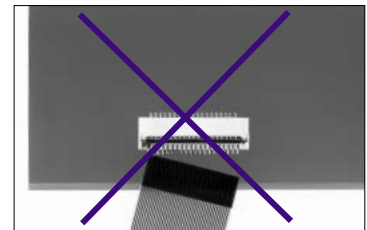
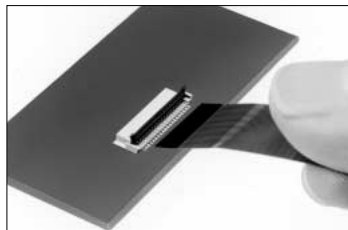
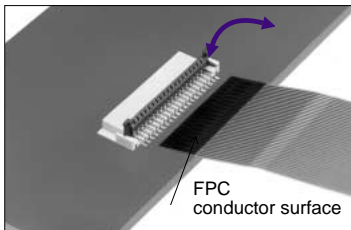

- 3 Rotate down the actuator until firmly closed.
NOTE: The FPC must be fully inserted in the connector. If not fully inserted, the actuator will not close properly. Should this be the case, lift up the actuator (per Step 2 below) and repeat the process (starting with Step 1 above)

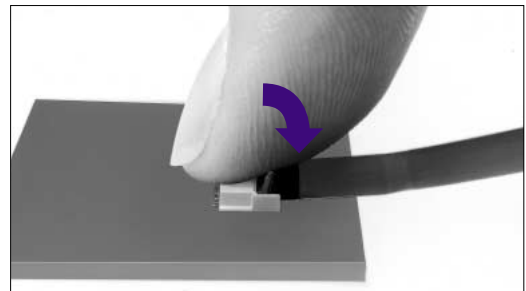

For connectors with multiple contacts, such as 39 and 61 pos. rotate down the actuator pushing at both ends.

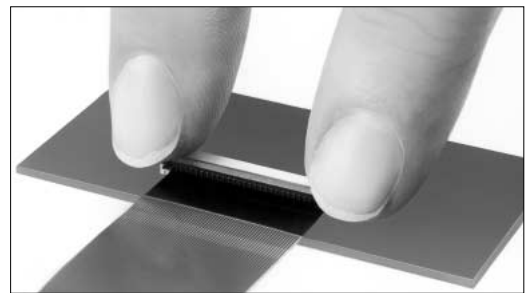

2. FPC Extraction Method

- 1 Lift up the actuator. Carefully remove the FPC.

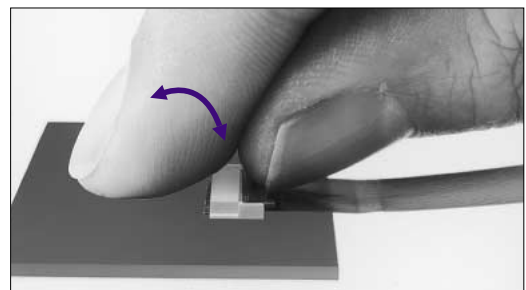

Precautions

- 1 The actuator is designed to withstand normal opening/closing operation. However, care should be taken not to use excessive force or grasping it with any type of tool.

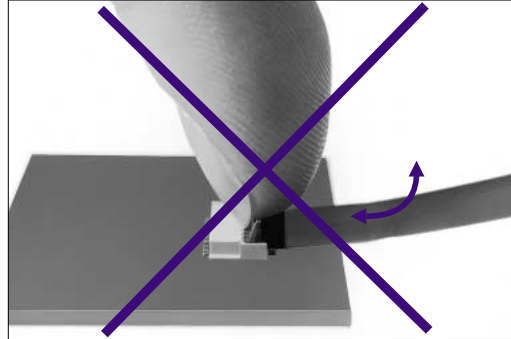
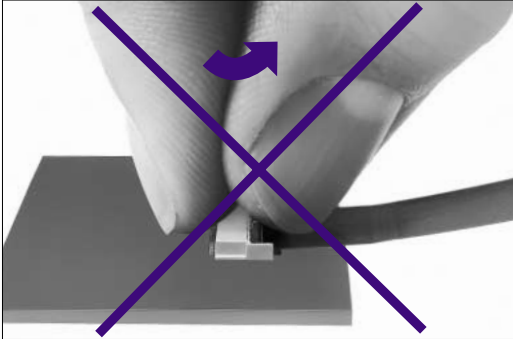

- 2 The actuator is designed to open/close 90° max. Cycling above this may cause discontinuity, damage or dislocation of the actuator.

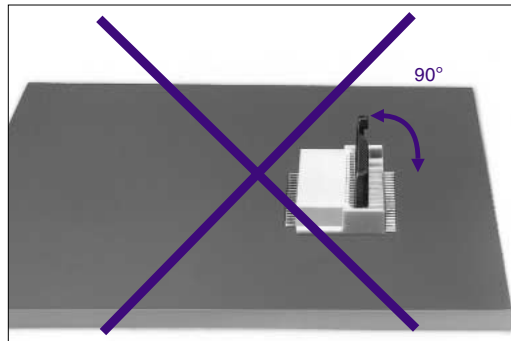

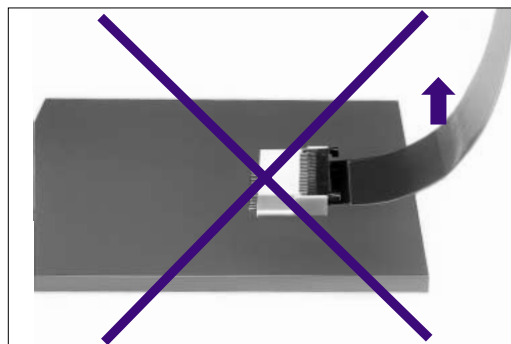

- 3 Do not apply pull forces on the FPC, especially in the upward direction. If needed, secure the FPC to avoid transfer of pull forces to the terminated connector.









Looking for pricing, stock, or lifecycle information?

Click below to explore more details on WIN SOURCE:

-  [View FH23-39S-0.3SHW\(10\) on WIN SOURCE](#)
-  [Hirose Electric Co Ltd Information](#)

Optimize Your Supply Chain with WIN SOURCE Solutions

-  Global Sourcing Solution
-  Obsolete Management
-  Cost Control Management
-  Shortage Management
-  Alternative Solution
-  Excess Inventory Management