



# THE DATASHEET OF CAVC2T45TDCURQ1



## DUAL-BIT DUAL-SUPPLY BUS TRANSCEIVER WITH CONFIGURABLE VOLTAGE TRANSLATION AND 3-STATE OUTPUTS

Check for Samples: [SN74AVC2T45-Q1](#)

### FEATURES

- Qualified for Automotive Applications
- Control Inputs  $V_{IH}/V_{IL}$  Levels Are Referenced to  $V_{CCA}$  Voltage
- Fully Configurable Dual-Rail Design Allows Each Port to Operate Over the Full 1.2-V to 3.6-V Power-Supply Range
- I/Os Are 4.6-V Tolerant
- $I_{off}$  Supports Partial-Power-Down Mode Operation
- Max Data Rates
  - 500 Mbps (1.8-V to 3.3-V Translation)
  - 320 Mbps (<1.8-V to 3.3-V Translation)
  - 320 Mbps (Translate to 2.5 V or 1.8 V)
  - 280 Mbps (Translate to 1.5 V)
  - 240 Mbps (Translate to 1.2 V)
- Latch-Up Performance Exceeds 100 mA Per JESD 78, Class II
- ESD Protection Exceeds JESD 22
  - 8000-V Human-Body Model (A114-A)
  - 200-V Machine Model (A115-A)
  - 1000-V Charged-Device Model (C101)

DCU PACKAGE  
(TOP VIEW)

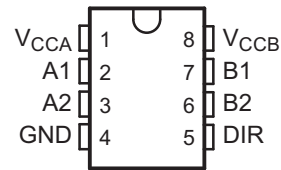

### DESCRIPTION

This dual-bit noninverting bus transceiver uses two separate configurable power-supply rails. The A port is designed to track  $V_{CCA}$ .  $V_{CCA}$  accepts any supply voltage from 1.2 V to 3.6 V. The B port is designed to track  $V_{CCB}$ .  $V_{CCB}$  accepts any supply voltage from 1.2 V to 3.6 V. This allows for universal low-voltage bidirectional translation between any of the 1.2-V, 1.5-V, 1.8-V, 2.5-V, and 3.3-V voltage nodes.

The SN74AVC2T45 is designed for asynchronous communication between two data buses. The logic levels of the direction-control (DIR) input activate either the B-port outputs or the A-port outputs. The device transmits data from the A bus to the B bus when the B-port outputs are activated and from the B bus to the A bus when the A-port outputs are activated. The input circuitry on both A and B ports always is active and must have a logic HIGH or LOW level applied to prevent excess  $I_{CC}$  and  $I_{CCZ}$ .

The SN74AVC2T45 is designed so that the DIR input is powered by  $V_{CCA}$ .

This device is fully specified for partial-power-down applications using  $I_{off}$ . The  $I_{off}$  circuitry disables the outputs, preventing damaging current backflow through the device when it is powered down.

The  $V_{CC}$  isolation feature ensures that if either  $V_{CC}$  input is at GND, both ports are in the high-impedance state.

### ORDERING INFORMATION<sup>(1)</sup>

$T_A$	PACKAGE <sup>(2)</sup>		ORDERABLE PART NUMBER	TOP-SIDE MARKING
–40°C to 105°C	VSSOP – DCU	Reel of 3000	CAVC2T45TDCURQ1	SBUI

(1) For the most current package and ordering information, see the Package Option Addendum at the end of this document, or see the TI web site at [www.ti.com](http://www.ti.com).

(2) Package drawings, thermal data, and symbolization are available at [www.ti.com/packaging](http://www.ti.com/packaging).



Please be aware that an important notice concerning availability, standard warranty, and use in critical applications of Texas Instruments semiconductor products and disclaimers thereto appears at the end of this data sheet.

**FUNCTION TABLE<sup>(1)</sup>  
(EACH TRANSCEIVER)**

INPUT DIR	OPERATION
L	B data to A bus
H	A data to B bus

(1) Input circuits of the data I/Os always are active.

**LOGIC DIAGRAM (POSITIVE LOGIC)**

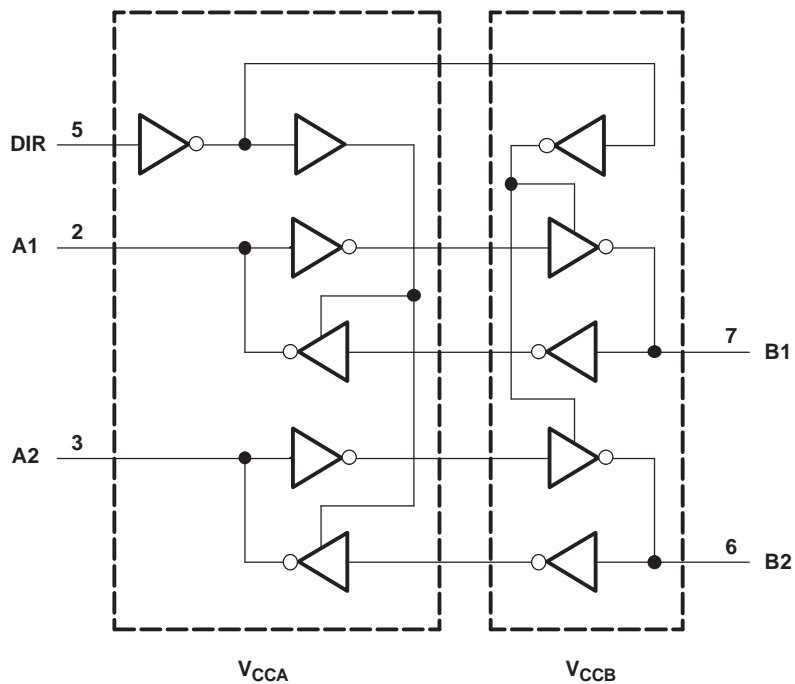

**ABSOLUTE MAXIMUM RATINGS<sup>(1)</sup>**

over operating free-air temperature range (unless otherwise noted)

		MIN	MAX	UNIT	
$V_{CCA}$ $V_{CCB}$	Supply voltage range	–0.5	4.6	V	
$V_I$	Input voltage range <sup>(2)</sup>	I/O ports (A port)	–0.5	4.6	V
		I/O ports (B port)	–0.5	4.6	
		Control inputs	–0.5	4.6	
$V_O$	Voltage range applied to any output in the high-impedance or power-off state <sup>(2)</sup>	A port	–0.5	4.6	V
		B port	–0.5	4.6	
$V_O$	Voltage range applied to any output in the high or low state <sup>(2) (3)</sup>	A port	–0.5	$V_{CCA} + 0.5$	V
		B port	–0.5	$V_{CCB} + 0.5$	
$I_{IK}$	Input clamp current	$V_I < 0$	–50	mA	
$I_{OK}$	Output clamp current	$V_O < 0$	–50	mA	
$I_O$	Continuous output current		±50	mA	
	Continuous current through $V_{CCA}$ , $V_{CCB}$ , or GND		±100	mA	
$\theta_{JA}$	Package thermal impedance <sup>(4)</sup>	DCU package	227	°C/W	
$T_{stg}$	Storage temperature range	–65	150	°C	

- (1) Stresses beyond those listed under "absolute maximum ratings" may cause permanent damage to the device. These are stress ratings only, and functional operation of the device at these or any other conditions beyond those indicated under "recommended operating conditions" is not implied. Exposure to absolute-maximum-rated conditions for extended periods may affect device reliability.
- (2) The input negative-voltage and output voltage ratings may be exceeded if the input and output current ratings are observed.
- (3) The output positive-voltage rating may be exceeded up to 4.6 V maximum if the output current ratings are observed.
- (4) The package thermal impedance is calculated in accordance with JESD 51-7.

**RECOMMENDED OPERATING CONDITIONS** (1)(2)(3)(4)(5)

		$V_{CCI}$	$V_{CCO}$	MIN	MAX	UNIT
$V_{CCA}$	Supply voltage			1.2	3.6	V
$V_{CCB}$	Supply voltage			1.2	3.6	V
$V_{IH}$	High-level input voltage	Data inputs <sup>(4)</sup>	1.2 V to 1.95 V	$V_{CCI} \times 0.65$		V
			1.95 V to 2.7 V	1.6		
			2.7 V to 3.6 V	2		
$V_{IL}$	Low-level input voltage	Data inputs <sup>(4)</sup>	1.2 V to 1.95 V	$V_{CCI} \times 0.35$		V
			1.95 V to 2.7 V	0.7		
			2.7 V to 3.6 V	0.8		
$V_{IH}$	High-level input voltage	DIR (referenced to $V_{CCA}$ ) <sup>(5)</sup>	1.2 V to 1.95 V	$V_{CCA} \times 0.65$		V
			1.95 V to 2.7 V	1.6		
			2.7 V to 3.6 V	2		
$V_{IL}$	Low-level input voltage	DIR (referenced to $V_{CCA}$ ) <sup>(5)</sup>	1.2 V to 1.95 V	$V_{CCA} \times 0.35$		V
			1.95 V to 2.7 V	0.7		
			2.7 V to 3.6 V	0.8		
$V_I$	Input voltage			0	3.6	V
$V_O$	Output voltage	Active state		0	$V_{CCO}$	V
		3-state		0	3.6	
$I_{OH}$	High-level output current		1.2 V	–3		mA
			1.4 V to 1.6 V	–6		
			1.65 V to 1.95 V	–8		
			2.3 V to 2.7 V	–9		
			3 V to 3.6 V	–12		
$I_{OL}$	Low-level output current		1.2 V	3		mA
			1.4 V to 1.6 V	6		
			1.65 V to 1.95 V	8		
			2.3 V to 2.7 V	9		
			3 V to 3.6 V	12		
$\Delta t/\Delta v$	Input transition rise or fall rate				5	ns/V
$T_A$	Operating free-air temperature			–40	105	°C

(1)  $V_{CCI}$  is the  $V_{CC}$  associated with the input port.

(2)  $V_{CCO}$  is the  $V_{CC}$  associated with the output port.

(3) All unused data inputs of the device must be held at  $V_{CCI}$  or GND to ensure proper device operation. See the TI application report, *Implications of Slow or Floating CMOS Inputs*, literature number [SCBA004](#).

(4) For  $V_{CCI}$  values not specified in the data sheet,  $V_{IH}$  min =  $V_{CCI} \times 0.7$  V,  $V_{IL}$  max =  $V_{CCI} \times 0.3$  V.

(5) For  $V_{CCI}$  values not specified in the data sheet,  $V_{IH}$  min =  $V_{CCA} \times 0.7$  V,  $V_{IL}$  max =  $V_{CCA} \times 0.3$  V.

**ELECTRICAL CHARACTERISTICS<sup>(1)(2)</sup>**

over recommended operating free-air temperature range (unless otherwise noted)

PARAMETER	TEST CONDITIONS		V <sub>CCA</sub>	V <sub>CCB</sub>	T <sub>A</sub> = 25°C			–40°C to 105°C		UNIT
					MIN	TYP	MAX	MIN	MAX	
V <sub>OH</sub>		V <sub>I</sub> = V <sub>IH</sub>	I <sub>OH</sub> = –100 μA	1.2 V to 3.6 V	1.2 V to 3.6 V			V <sub>CCO</sub> – 0.2 V		V
			I <sub>OH</sub> = –3 mA	1.2 V	1.2 V	0.95				
			I <sub>OH</sub> = –6 mA	1.4 V	1.4 V		1.05			
			I <sub>OH</sub> = –8 mA	1.65 V	1.65 V		1.2			
			I <sub>OH</sub> = –9 mA	2.3 V	2.3 V		1.75			
			I <sub>OH</sub> = –12 mA	3 V	3 V		2.3			
V <sub>OL</sub>		V <sub>I</sub> = V <sub>IL</sub>	I <sub>OL</sub> = 100 μA	1.2 V to 3.6 V	1.2 V to 3.6 V			0.2		V
			I <sub>OL</sub> = 3 mA	1.2 V	1.2 V	0.25				
			I <sub>OL</sub> = 6 mA	1.4 V	1.4 V		0.35			
			I <sub>OL</sub> = 8 mA	1.65 V	1.65 V		0.45			
			I <sub>OL</sub> = 9 mA	2.3 V	2.3 V		0.55			
			I <sub>OL</sub> = 12 mA	3 V	3 V		0.7			
I <sub>I</sub>	DIR	V <sub>I</sub> = V <sub>CCA</sub> or GND	1.2 V to 3.6 V	1.2 V to 3.6 V	±0.025	±0.25		±1	μA	
I <sub>off</sub>	A port	V <sub>I</sub> or V <sub>O</sub> = 0 to 3.6 V	0 V	0 to 3.6 V	±0.1	±1		±5	μA	
	B port		0 to 3.6 V	0 V	±0.1	±1		±5		
I <sub>OZ</sub>	B port	V <sub>O</sub> = V <sub>CCO</sub> or GND, V <sub>I</sub> = V <sub>CCI</sub> or GND	0 V	3.6 V	±0.5	±2.5		±5	μA	
	A port		3.6 V	0 V	±0.5	±2.5		±5		
I <sub>CCA</sub>		V <sub>I</sub> = V <sub>CCI</sub> or GND, I <sub>O</sub> = 0	1.2 V to 3.6 V	1.2 V to 3.6 V				10	μA	
			0 V	3.6 V				–2		
			3.6 V	0 V				10		
I <sub>CCB</sub>		V <sub>I</sub> = V <sub>CCI</sub> or GND, I <sub>O</sub> = 0	1.2 V to 3.6 V	1.2 V to 3.6 V				10	μA	
			0 V	3.6 V				10		
			3.6 V	0 V				–2		
I <sub>CCA</sub> + I <sub>CCB</sub> (see Table 1)		V <sub>I</sub> = V <sub>CCI</sub> or GND, I <sub>O</sub> = 0	1.2 V to 3.6 V	1.2 V to 3.6 V				20	μA	
C <sub>I</sub>	Control inputs	V <sub>I</sub> = 3.3 V or GND	3.3 V	3.3 V	2.5				pF	
C <sub>io</sub>	A or B port	V <sub>O</sub> = 3.3 V or GND	3.3 V	3.3 V	6				pF	

(1) V<sub>CCO</sub> is the V<sub>CC</sub> associated with the output port.

(2) V<sub>CCI</sub> is the V<sub>CC</sub> associated with the input port.

## SWITCHING CHARACTERISTICS

over recommended operating free-air temperature range,  $V_{CCA} = 1.2\text{ V}$  (see [Figure 1](#))

PARAMETER	FROM (INPUT)	TO (OUTPUT)	$V_{CCB} = 1.2\text{ V}$	$V_{CCB} = 1.5\text{ V}$	$V_{CCB} = 1.8\text{ V}$	$V_{CCB} = 2.5\text{ V}$	$V_{CCB} = 3.3\text{ V}$	UNIT
			TYP	TYP	TYP	TYP	TYP	
$t_{PLH}$	A	B	3.1	2.6	2.4	2.2	2.2	ns
$t_{PHL}$			3.1	2.6	2.4	2.2	2.2	
$t_{PLH}$	B	A	3.4	3.1	3	2.9	2.9	ns
$t_{PHL}$			3.4	3.1	3	2.9	2.9	
$t_{PHZ}$	DIR	A	5.2	5.2	5.1	5	4.8	ns
$t_{PLZ}$			5.2	5.2	5.1	5	4.8	
$t_{PHZ}$	DIR	B	5	4	3.8	2.8	3.2	ns
$t_{PLZ}$			5	4	3.8	2.8	3.2	
$t_{PZH}^{(1)}$	DIR	A	8.4	7.1	6.8	5.7	6.1	ns
$t_{PZL}^{(1)}$			8.4	7.1	6.8	5.7	6.1	
$t_{PZH}^{(1)}$	DIR	B	8.3	7.8	7.5	7.2	7	ns
$t_{PZL}^{(1)}$			8.3	7.8	7.5	7.2	7	

(1) The enable time is a calculated value, derived using the formula shown in the [enable times](#) section.

## SWITCHING CHARACTERISTICS

over recommended operating free-air temperature range,  $V_{CCA} = 1.5\text{ V} \pm 0.1\text{ V}$  (see [Figure 1](#))

PARAMETER	FROM (INPUT)	TO (OUTPUT)	$V_{CCB} = 1.2\text{ V}$	$V_{CCB} = 1.5\text{ V} \pm 0.1\text{ V}$		$V_{CCB} = 1.8\text{ V} \pm 0.15\text{ V}$		$V_{CCB} = 2.5\text{ V} \pm 0.2\text{ V}$		$V_{CCB} = 3.3\text{ V} \pm 0.3\text{ V}$		UNIT
			TYP	MIN	MAX	MIN	MAX	MIN	MAX	MIN	MAX	
$t_{PLH}$	A	B	2.8	0.7	5.6	0.5	4.8	0.4	3.9	0.3	3.7	ns
$t_{PHL}$			2.8	0.7	5.6	0.5	4.8	0.4	3.9	0.3	3.7	
$t_{PLH}$	B	A	2.7	0.8	5.6	0.7	5.4	0.6	5.1	0.5	4.9	ns
$t_{PHL}$			2.7	0.8	5.6	0.7	5.4	0.6	5.1	0.5	4.9	
$t_{PHZ}$	DIR	A	3.9	1.3	8.7	1.3	8	1.1	7.9	1.4	7.8	ns
$t_{PLZ}$			3.9	1.3	8.7	1.3	8	1.1	7.9	1.4	7.8	
$t_{PHZ}$	DIR	B	4.7	1.1	7.2	1.4	7.1	1.2	7.1	1.7	7.3	ns
$t_{PLZ}$			4.7	1.1	7.2	1.4	7.1	1.2	7.1	1.7	7.3	
$t_{PZH}^{(1)}$	DIR	A	7.4	12.6		12.3		12		12		ns
$t_{PZL}^{(1)}$			7.4	12.6		12.3		12		12		
$t_{PZH}^{(1)}$	DIR	B	6.7	14.1		12.6		11.6		11.3		ns
$t_{PZL}^{(1)}$			6.7	14.1		12.6		11.6		11.3		

(1) The enable time is a calculated value, derived using the formula shown in the [enable times](#) section.

## SWITCHING CHARACTERISTICS

 over recommended operating free-air temperature range,  $V_{CCA} = 1.8\text{ V} \pm 0.15\text{ V}$  (see [Figure 1](#))

PARAMETER	FROM (INPUT)	TO (OUTPUT)	$V_{CCB} = 1.2\text{ V}$	$V_{CCB} = 1.5\text{ V} \pm 0.1\text{ V}$		$V_{CCB} = 1.8\text{ V} \pm 0.15\text{ V}$		$V_{CCB} = 2.5\text{ V} \pm 0.2\text{ V}$		$V_{CCB} = 3.3\text{ V} \pm 0.3\text{ V}$		UNIT
			TYP	MIN	MAX	MIN	MAX	MIN	MAX	MIN	MAX	
$t_{PLH}$	A	B	2.7	0.5	5.4	0.4	4.5	0.2	3.6	0.2	3.3	ns
$t_{PHL}$			2.7	0.5	5.4	0.4	4.5	0.2	3.6	0.2	3.3	
$t_{PLH}$	B	A	2.4	0.7	4.9	0.5	4.6	0.5	4.2	0.4	4	ns
$t_{PHL}$			2.4	0.7	4.9	0.5	4.6	0.5	4.2	0.4	4	
$t_{PHZ}$	DIR	A	3.7	1.3	8.3	0.7	7.1	1.4	5.5	1.1	5.4	ns
$t_{PLZ}$			3.7	1.3	8.3	0.7	7.1	1.4	5.5	1.1	5.4	
$t_{PHZ}$	DIR	B	4.4	1.3	6	1.3	6.1	0.8	5.9	1.5	6.1	ns
$t_{PLZ}$			4.4	1.3	6	1.3	6.1	0.8	5.9	1.5	6.1	
$t_{PZH}^{(1)}$	DIR	A	6.8	10.7		10.5		9.9		9.9		ns
$t_{PZL}^{(1)}$			6.8	10.7		10.5		9.9		9.9		
$t_{PZH}^{(1)}$	DIR	B	6.4	13.5		11.4		8.9		8.5		ns
$t_{PZL}^{(1)}$			6.4	13.5		11.4		8.9		8.5		

 (1) The enable time is a calculated value, derived using the formula shown in the [enable times](#) section.

## SWITCHING CHARACTERISTICS

 over recommended operating free-air temperature range,  $V_{CCA} = 2.5\text{ V} \pm 0.2\text{ V}$  (see [Figure 1](#))

PARAMETER	FROM (INPUT)	TO (OUTPUT)	$V_{CCB} = 1.2\text{ V}$	$V_{CCB} = 1.5\text{ V} \pm 0.1\text{ V}$		$V_{CCB} = 1.8\text{ V} \pm 0.15\text{ V}$		$V_{CCB} = 2.5\text{ V} \pm 0.2\text{ V}$		$V_{CCB} = 3.3\text{ V} \pm 0.3\text{ V}$		UNIT
			TYP	MIN	MAX	MIN	MAX	MIN	MAX	MIN	MAX	
$t_{PLH}$	A	B	2.6	0.4	5.1	0.2	4.2	0.2	3.2	0.2	2.8	ns
$t_{PHL}$			2.6	0.4	5.1	0.2	4.2	0.2	3.2	0.2	2.8	
$t_{PLH}$	B	A	2.1	0.6	4	0.5	3.6	0.4	3.2	0.3	3	ns
$t_{PHL}$			2.1	0.6	4	0.5	3.6	0.4	3.2	0.3	3	
$t_{PHZ}$	DIR	A	2.4	0.7	8.1	0.8	6.6	0.8	5.2	0.5	4.5	ns
$t_{PLZ}$			2.4	0.7	8.1	0.8	6.6	0.8	5.2	0.5	4.5	
$t_{PHZ}$	DIR	B	3.8	1	4.5	0.6	4.5	0.5	4.4	1.1	4.3	ns
$t_{PLZ}$			3.8	1	4.5	0.6	4.5	0.5	4.4	1.1	4.3	
$t_{PZH}^{(1)}$	DIR	A	5.9	8.7		7.9		7.4		7.1		ns
$t_{PZL}^{(1)}$			5.9	8.7		7.9		7.4		7.1		
$t_{PZH}^{(1)}$	DIR	B	5	13		10.6		8.2		7.1		ns
$t_{PZL}^{(1)}$			5	13		10.6		8.2		7.1		

 (1) The enable time is a calculated value, derived using the formula shown in the [enable times](#) section.

## SWITCHING CHARACTERISTICS

over recommended operating free-air temperature range,  $V_{CCA} = 3.3 \text{ V} \pm 0.3 \text{ V}$  (see [Figure 1](#))

PARAMETER	FROM (INPUT)	TO (OUTPUT)	$V_{CCB} = 1.2 \text{ V}$	$V_{CCB} = 1.5 \text{ V} \pm 0.1 \text{ V}$		$V_{CCB} = 1.8 \text{ V} \pm 0.15 \text{ V}$		$V_{CCB} = 2.5 \text{ V} \pm 0.2 \text{ V}$		$V_{CCB} = 3.3 \text{ V} \pm 0.3 \text{ V}$		UNIT
			TYP	MIN	MAX	MIN	MAX	MIN	MAX	MIN	MAX	
$t_{PLH}$	A	B	2.5	0.3	4.9	0.2	4	0.2	3	0.2	2.6	ns
$t_{PHL}$			2.5	0.3	4.9	0.2	4	0.2	3	0.2	2.6	
$t_{PLH}$	B	A	2.1	0.6	3.8	0.4	3.3	0.3	2.8	0.3	2.6	ns
$t_{PHL}$			2.1	0.6	3.8	0.4	3.3	0.3	2.8	0.3	2.6	
$t_{PHZ}$	DIR	A	2.9	1.1	8.2	1	6.7	1.3	4.9	1.2	4.2	ns
$t_{PLZ}$			2.9	1.1	8.2	1	6.7	1.3	4.9	1.2	4.2	
$t_{PHZ}$	DIR	B	3.4	0.5	6.8	0.3	5.8	0.3	4.8	1.1	4.4	ns
$t_{PLZ}$			3.4	0.5	6.8	0.3	5.8	0.3	4.8	1.1	4.4	
$t_{PZH}^{(1)}$	DIR	A	5.5	10.4		8.9		7.4		6.8		ns
$t_{PZL}^{(1)}$			5.5	10.4		8.9		7.4		6.8		
$t_{PZH}^{(1)}$	DIR	B	5.4	12.9		10.5		7.7		6.6		ns
$t_{PZL}^{(1)}$			5.4	12.9		10.5		7.7		6.6		

(1) The enable time is a calculated value, derived using the formula shown in the [enable times](#) section.

## OPERATING CHARACTERISTICS

$T_A = 25^\circ\text{C}$

PARAMETER		TEST CONDITIONS	$V_{CCA} =$ $V_{CCB} = 1.2 \text{ V}$	$V_{CCA} =$ $V_{CCB} = 1.5 \text{ V}$	$V_{CCA} =$ $V_{CCB} = 1.8 \text{ V}$	$V_{CCA} =$ $V_{CCB} = 2.5 \text{ V}$	$V_{CCA} =$ $V_{CCB} = 3.3 \text{ V}$	UNIT
			TYP	TYP	TYP	TYP	TYP	
$C_{pdA}^{(1)}$	A-port input, B-port output	$C_L = 0,$ $f = 10 \text{ MHz},$ $t_r = t_f = 1 \text{ ns}$	3	3	3	3	4	pF
	B-port input, A-port output		12	13	13	14	15	
$C_{pdB}^{(1)}$	A-port input, B-port output	$C_L = 0,$ $f = 10 \text{ MHz},$ $t_r = t_f = 1 \text{ ns}$	12	13	13	14	15	pF
	B-port input, A-port output		3	3	3	3	4	

(1) Power-dissipation capacitance per transceiver

## Power-Up Considerations

A proper power-up sequence always should be followed to avoid excessive supply current, bus contention, oscillations, or other anomalies. To guard against such power-up problems, take the following precautions:

1. Connect ground before any supply voltage is applied.
2. Power up  $V_{CCA}$ .
3.  $V_{CCB}$  can be ramped up along with or after  $V_{CCA}$ .

**Table 1. Typical Total Static Power Consumption ( $I_{CCA} + I_{CCB}$ )**

$V_{CCB}$	$V_{CCA}$						UNIT
	0 V	1.2 V	1.5 V	1.8 V	2.5 V	3.3 V	
0 V	0	<0.5	<0.5	<0.5	<0.5	<0.5	μA
1.2 V	<0.5	<1	<1	<1	<1	1	
1.5 V	<0.5	<1	<1	<1	<1	1	
1.8 V	<0.5	<1	<1	<1	<1	<1	
2.5 V	<0.5	1	<1	<1	<1	<1	
3.3 V	<0.5	1	<1	<1	<1	<1	

TYPICAL CHARACTERISTICS

TYPICAL PROPAGATION DELAY (A to B) vs LOAD CAPACITANCE,  
 $T_A = 25^\circ\text{C}$ ,  $V_{CCA} = 1.2\text{ V}$

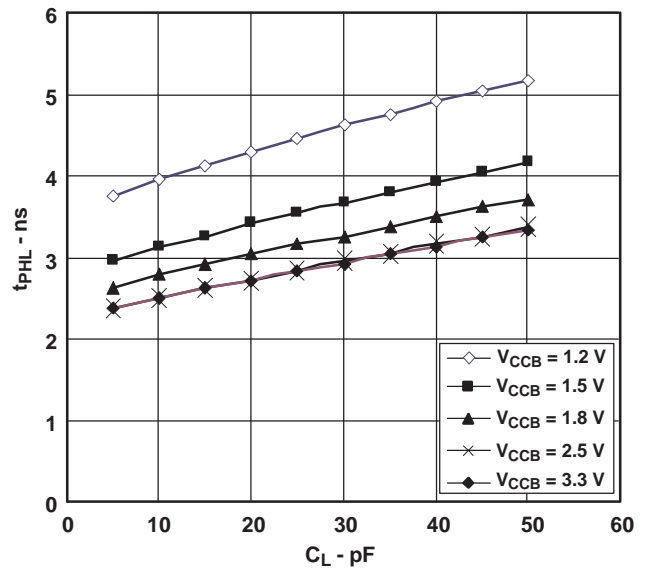
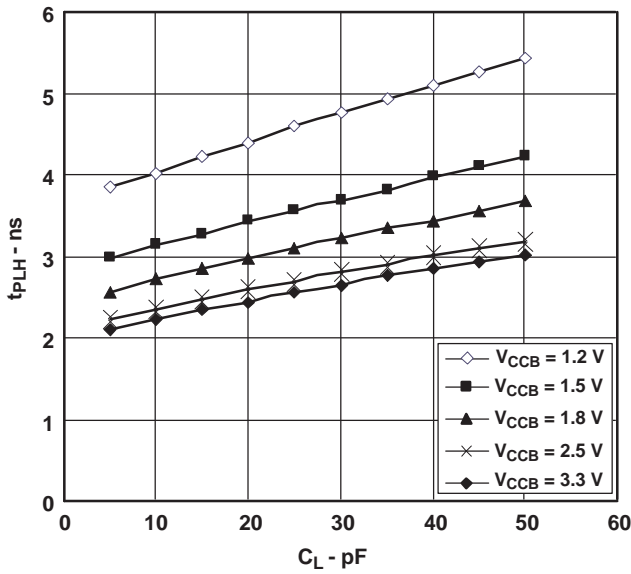

TYPICAL PROPAGATION DELAY (A to B) vs LOAD CAPACITANCE,  
 $T_A = 25^\circ\text{C}$ ,  $V_{CCA} = 1.5\text{ V}$

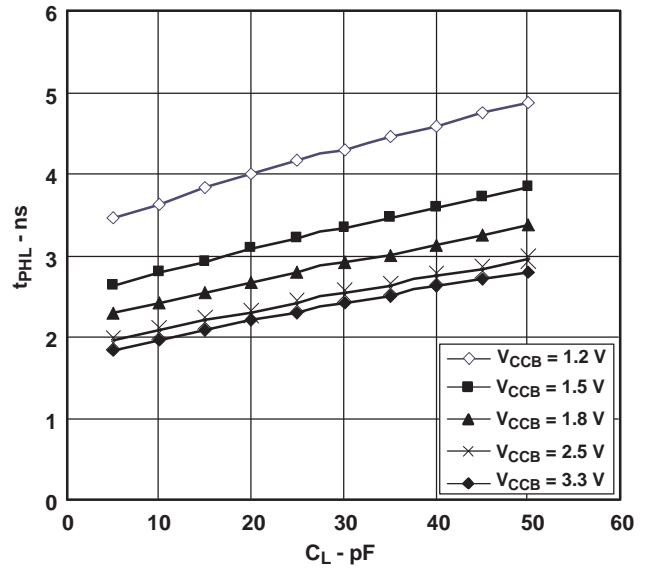
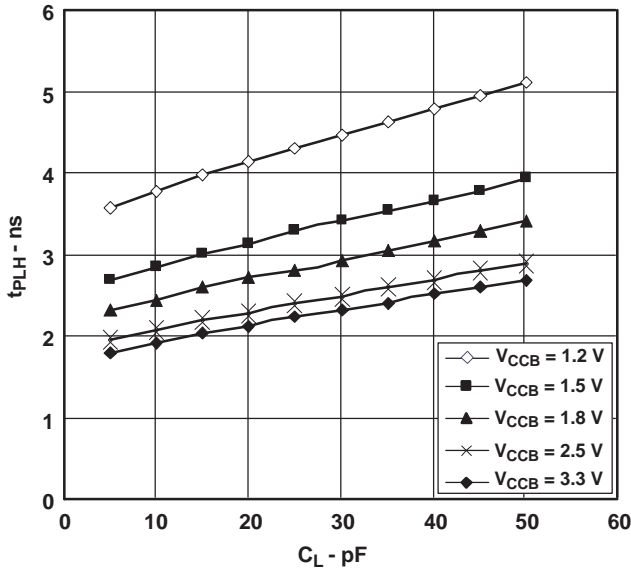

TYPICAL CHARACTERISTICS (continued)

TYPICAL PROPAGATION DELAY (A to B) vs LOAD CAPACITANCE,  
 $T_A = 25^\circ\text{C}$ ,  $V_{CCA} = 1.8\text{ V}$

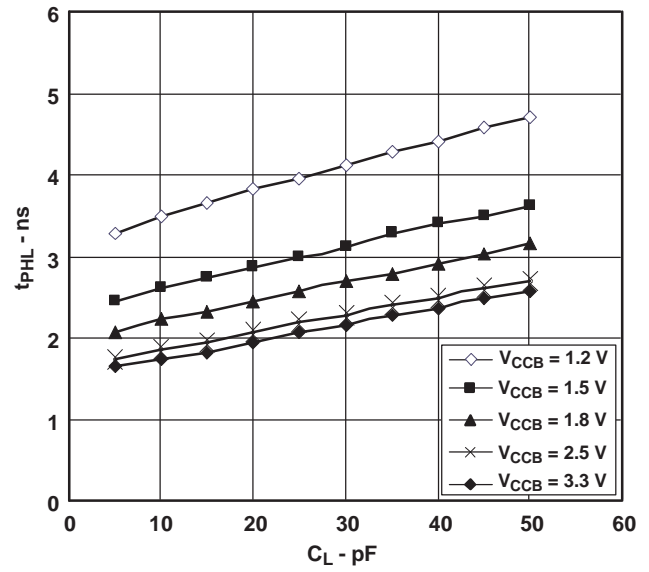
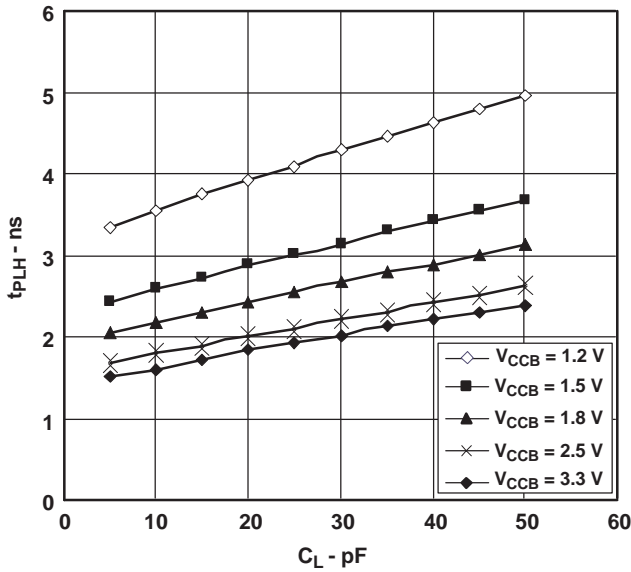

TYPICAL PROPAGATION DELAY (A to B) vs LOAD CAPACITANCE,  
 $T_A = 25^\circ\text{C}$ ,  $V_{CCA} = 2.5\text{ V}$

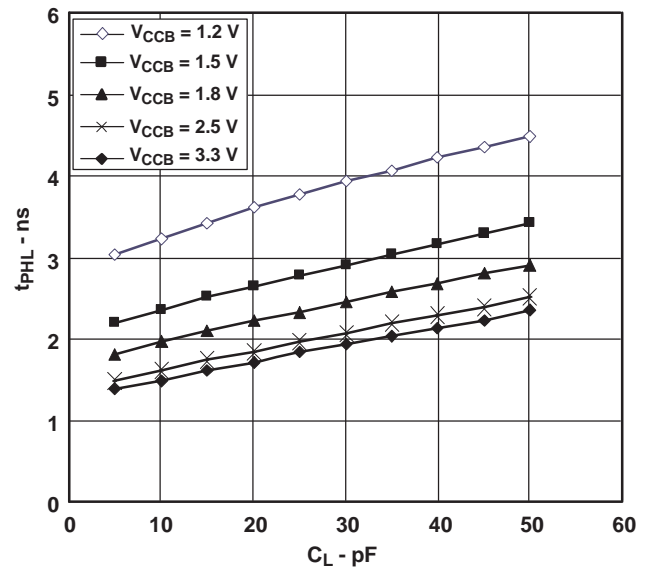
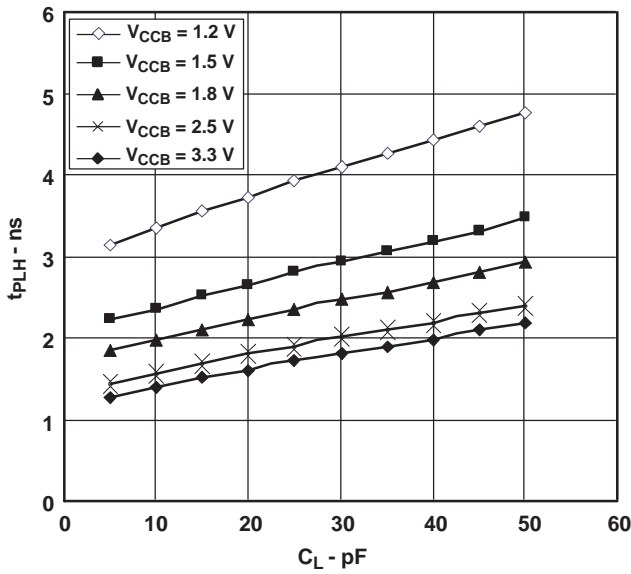

**TYPICAL CHARACTERISTICS (continued)**  
**TYPICAL PROPAGATION DELAY (A to B) vs LOAD CAPACITANCE,**  
 $T_A = 25^\circ\text{C}, V_{CCA} = 3.3\text{ V}$

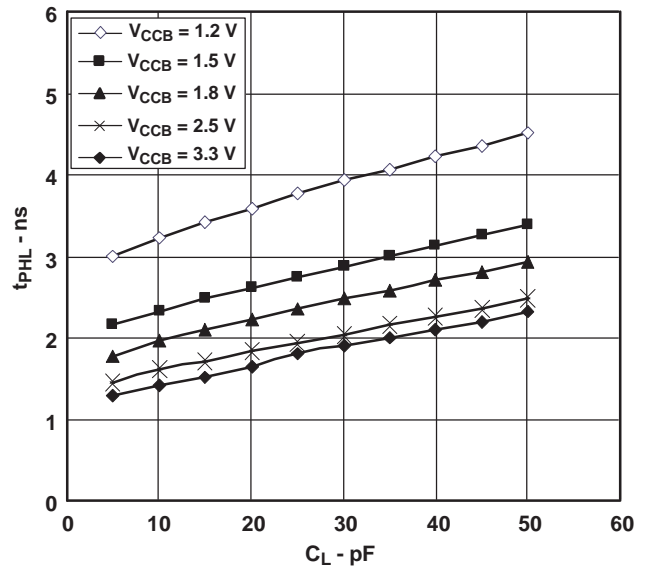
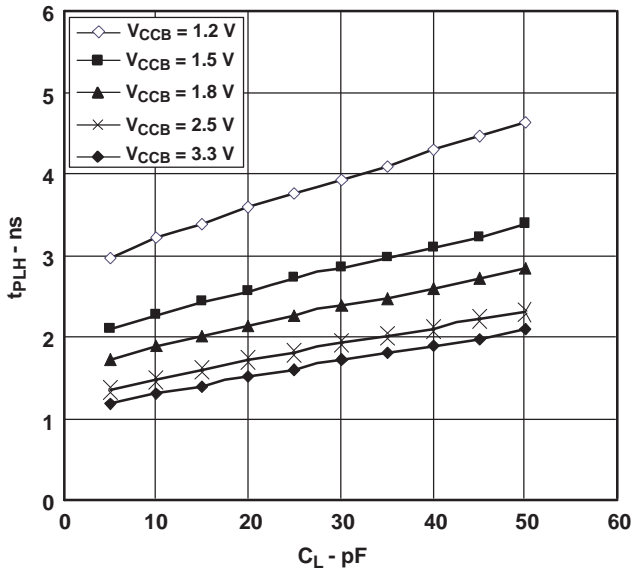

PARAMETER MEASUREMENT INFORMATION

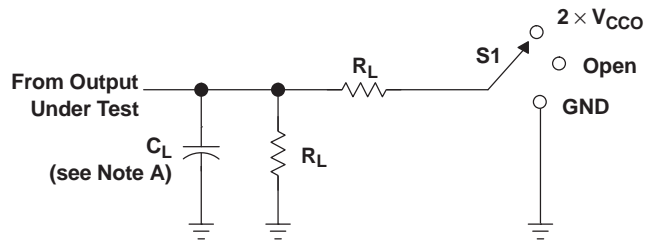

LOAD CIRCUIT

TEST	S1
$t_{pd}$	Open
$t_{PLZ}/t_{PZL}$	$2 \times V_{CCO}$
$t_{PHZ}/t_{PZH}$	GND

$V_{CCO}$	$C_L$	$R_L$	$V_{TP}$
1.2 V	15 pF	2 k $\Omega$	0.1 V
1.5 V $\pm$ 0.1 V	15 pF	2 k $\Omega$	0.1 V
1.8 V $\pm$ 0.15 V	15 pF	2 k $\Omega$	0.15 V
2.5 V $\pm$ 0.2 V	15 pF	2 k $\Omega$	0.15 V
3.3 V $\pm$ 0.3 V	15 pF	2 k $\Omega$	0.3 V

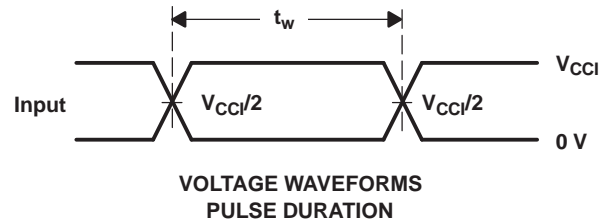

VOLTAGE WAVEFORMS PULSE DURATION

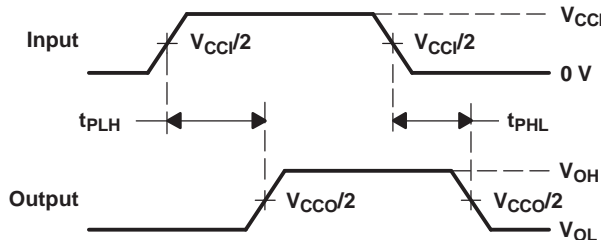

VOLTAGE WAVEFORMS PROPAGATION DELAY TIMES

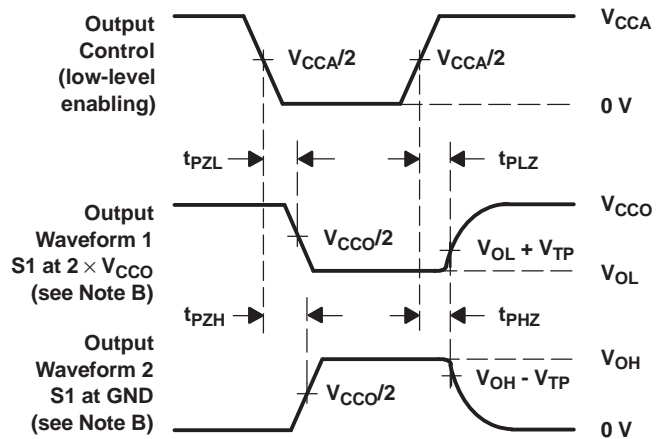

VOLTAGE WAVEFORMS ENABLE AND DISABLE TIMES

- NOTES:
- A.  $C_L$  includes probe and jig capacitance.
  - B. Waveform 1 is for an output with internal conditions such that the output is low, except when disabled by the output control. Waveform 2 is for an output with internal conditions such that the output is high, except when disabled by the output control.
  - C. All input pulses are supplied by generators having the following characteristics:  $PRR \leq 10$  MHz,  $Z_O = 50 \Omega$ ,  $dv/dt \geq 1$  V/ns.
  - D. The outputs are measured one at a time, with one transition per measurement.
  - E.  $t_{PLZ}$  and  $t_{PHZ}$  are the same as  $t_{dis}$ .
  - F.  $t_{PZL}$  and  $t_{PZH}$  are the same as  $t_{en}$ .
  - G.  $t_{PLH}$  and  $t_{PHL}$  are the same as  $t_{pd}$ .
  - H.  $V_{CCI}$  is the  $V_{CC}$  associated with the input port.
  - I.  $V_{CCO}$  is the  $V_{CC}$  associated with the output port.

Figure 1. Load Circuit and Voltage Waveforms

**APPLICATION INFORMATION**

Figure 2 is an example circuit of the SN74AVC2T45 used in a unidirectional logic level-shifting application.

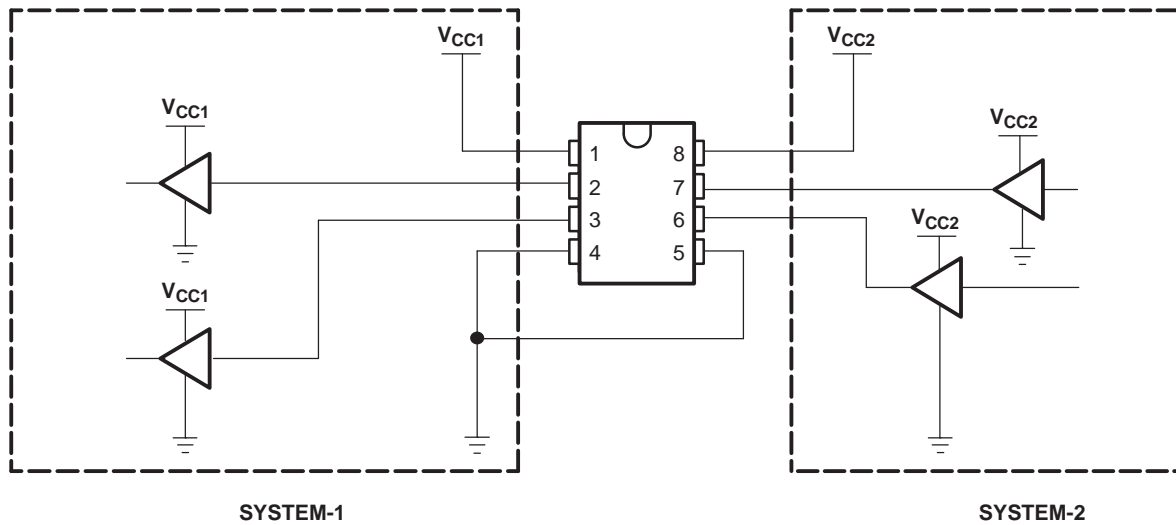

PIN	NAME	FUNCTION	DESCRIPTION
1	V <sub>CCA</sub>	V <sub>CC1</sub>	SYSTEM-1 supply voltage (1.2 V to 3.6 V)
2	A1	OUT1	Output level depends on V <sub>CC1</sub> voltage.
3	A2	OUT2	Output level depends on V <sub>CC1</sub> voltage.
4	GND	GND	Device GND
5	DIR	DIR	The GND (low-level) determines B-port to A-port direction.
6	B2	IN2	Input threshold value depends on V <sub>CC2</sub> voltage.
7	B1	IN1	Input threshold value depends on V <sub>CC2</sub> voltage.
8	V <sub>CCB</sub>	V <sub>CC2</sub>	SYSTEM-2 supply voltage (1.2 V to 3.6 V)

**Figure 2. Unidirectional Logic Level-Shifting Application**

## APPLICATION INFORMATION

Figure 3 shows the SN74AVC2T45 used in a bidirectional logic level-shifting application. Since the SN74AVC2T45 does not have an output-enable (OE) pin, the system designer should take precautions to avoid bus contention between SYSTEM-1 and SYSTEM-2 when changing directions.

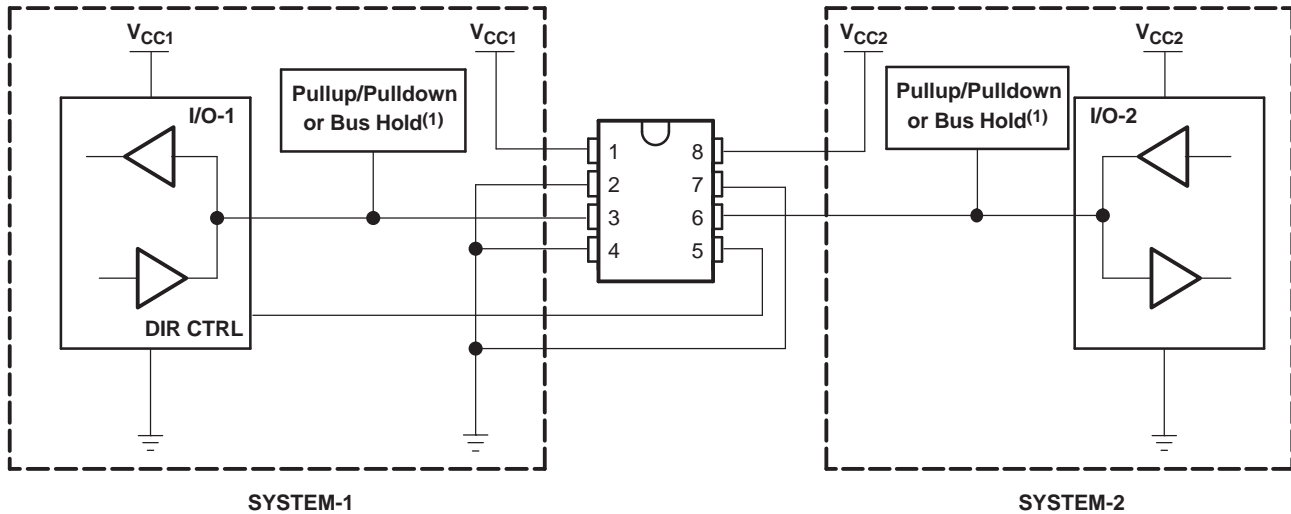

Following is a sequence that illustrates data transmission from SYSTEM-1 to SYSTEM-2 and then from SYSTEM-2 to SYSTEM-1.

STATE	DIR CTRL	I/O-1	I/O-2	DESCRIPTION
1	H	Out	In	SYSTEM-1 data to SYSTEM-2
2	H	Hi-Z	Hi-Z	SYSTEM-2 is getting ready to send data to SYSTEM-1. I/O-1 and I/O-2 are disabled. The bus-line state depends on pullup or pulldown. <sup>(1)</sup>
3	L	Hi-Z	Hi-Z	DIR bit is flipped. I/O-1 and I/O-2 still are disabled. The bus-line state depends on pullup or pulldown. <sup>(1)</sup>
4	L	In	Out	SYSTEM-2 data to SYSTEM-1

(1) SYSTEM-1 and SYSTEM-2 must use the same conditions, i.e., both pullup or both pulldown.

**Figure 3. Bidirectional Logic Level-Shifting Application**

### Enable Times

Calculate the enable times for the SN74AVC2T45 using the following formulas:

- $t_{PZH} \text{ (DIR to A)} = t_{PLZ} \text{ (DIR to B)} + t_{PLH} \text{ (B to A)}$
- $t_{PZL} \text{ (DIR to A)} = t_{PHZ} \text{ (DIR to B)} + t_{PHL} \text{ (B to A)}$
- $t_{PZH} \text{ (DIR to B)} = t_{PLZ} \text{ (DIR to A)} + t_{PLH} \text{ (A to B)}$
- $t_{PZL} \text{ (DIR to B)} = t_{PHZ} \text{ (DIR to A)} + t_{PHL} \text{ (A to B)}$

In a bidirectional application, these enable times provide the maximum delay from the time the DIR bit is switched until an output is expected. For example, if the SN74AVC2T45 initially is transmitting from A to B, then the DIR bit is switched; the B port of the device must be disabled before presenting it with an input. After the B port has been disabled, an input signal applied to it appears on the corresponding A port after the specified propagation delay.

**PACKAGING INFORMATION**

Orderable Device	Status (1)	Package Type	Package Drawing	Pins	Package Qty	Eco Plan (2)	Lead/Ball Finish (6)	MSL Peak Temp (3)	Op Temp (°C)	Device Marking (4/5)	Samples
CAVC2T45TDCURQ1	ACTIVE	VSSOP	DCU	8	3000	Green (RoHS & no Sb/Br)	CU NIPDAU	Level-1-260C-UNLIM	-40 to 125	SBUI	<b>Samples</b>

(1) The marketing status values are defined as follows:

**ACTIVE:** Product device recommended for new designs.

**LIFEBUY:** TI has announced that the device will be discontinued, and a lifetime-buy period is in effect.

**NRND:** Not recommended for new designs. Device is in production to support existing customers, but TI does not recommend using this part in a new design.

**PREVIEW:** Device has been announced but is not in production. Samples may or may not be available.

**OBSELETE:** TI has discontinued the production of the device.

(2) Eco Plan - The planned eco-friendly classification: Pb-Free (RoHS), Pb-Free (RoHS Exempt), or Green (RoHS & no Sb/Br) - please check <http://www.ti.com/productcontent> for the latest availability information and additional product content details.

**TBD:** The Pb-Free/Green conversion plan has not been defined.

**Pb-Free (RoHS):** TI's terms "Lead-Free" or "Pb-Free" mean semiconductor products that are compatible with the current RoHS requirements for all 6 substances, including the requirement that lead not exceed 0.1% by weight in homogeneous materials. Where designed to be soldered at high temperatures, TI Pb-Free products are suitable for use in specified lead-free processes.

**Pb-Free (RoHS Exempt):** This component has a RoHS exemption for either 1) lead-based flip-chip solder bumps used between the die and package, or 2) lead-based die adhesive used between the die and leadframe. The component is otherwise considered Pb-Free (RoHS compatible) as defined above.

**Green (RoHS & no Sb/Br):** TI defines "Green" to mean Pb-Free (RoHS compatible), and free of Bromine (Br) and Antimony (Sb) based flame retardants (Br or Sb do not exceed 0.1% by weight in homogeneous material)

(3) MSL, Peak Temp. - The Moisture Sensitivity Level rating according to the JEDEC industry standard classifications, and peak solder temperature.

(4) There may be additional marking, which relates to the logo, the lot trace code information, or the environmental category on the device.

(5) Multiple Device Markings will be inside parentheses. Only one Device Marking contained in parentheses and separated by a "~" will appear on a device. If a line is indented then it is a continuation of the previous line and the two combined represent the entire Device Marking for that device.

(6) Lead/Ball Finish - Orderable Devices may have multiple material finish options. Finish options are separated by a vertical ruled line. Lead/Ball Finish values may wrap to two lines if the finish value exceeds the maximum column width.

**Important Information and Disclaimer:**The information provided on this page represents TI's knowledge and belief as of the date that it is provided. TI bases its knowledge and belief on information provided by third parties, and makes no representation or warranty as to the accuracy of such information. Efforts are underway to better integrate information from third parties. TI has taken and continues to take reasonable steps to provide representative and accurate information but may not have conducted destructive testing or chemical analysis on incoming materials and chemicals. TI and TI suppliers consider certain information to be proprietary, and thus CAS numbers and other limited information may not be available for release.

In no event shall TI's liability arising out of such information exceed the total purchase price of the TI part(s) at issue in this document sold by TI to Customer on an annual basis.

**OTHER QUALIFIED VERSIONS OF SN74AVC2T45-Q1 :**

- Catalog: [SN74AVC2T45](#)

## NOTE: Qualified Version Definitions:

- Catalog - TI's standard catalog product

## TAPE AND REEL INFORMATION

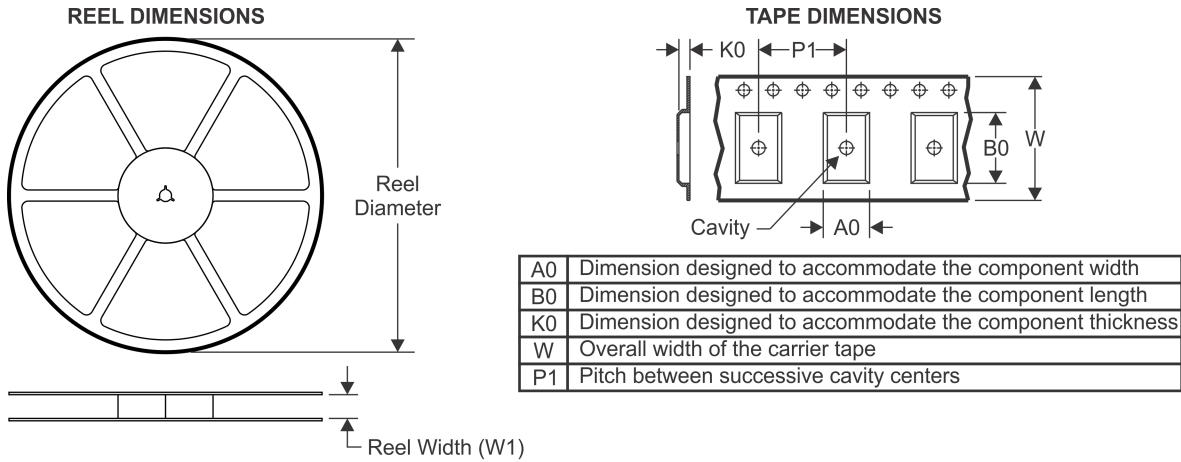

### QUADRANT ASSIGNMENTS FOR PIN 1 ORIENTATION IN TAPE

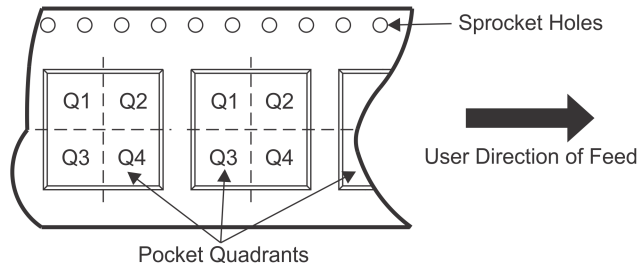

\*All dimensions are nominal

Device	Package Type	Package Drawing	Pins	SPQ	Reel Diameter (mm)	Reel Width W1 (mm)	A0 (mm)	B0 (mm)	K0 (mm)	P1 (mm)	W (mm)	Pin1 Quadrant
CAVC2T45TDCURQ1	VSSOP	DCU	8	3000	180.0	8.4	2.25	3.35	1.05	4.0	8.0	Q3

**TAPE AND REEL BOX DIMENSIONS**



\*All dimensions are nominal

Device	Package Type	Package Drawing	Pins	SPQ	Length (mm)	Width (mm)	Height (mm)
CAVC2T45TDCURQ1	VSSOP	DCU	8	3000	202.0	201.0	28.0

DCU (R-PDSO-G8)

PLASTIC SMALL-OUTLINE PACKAGE (DIE DOWN)

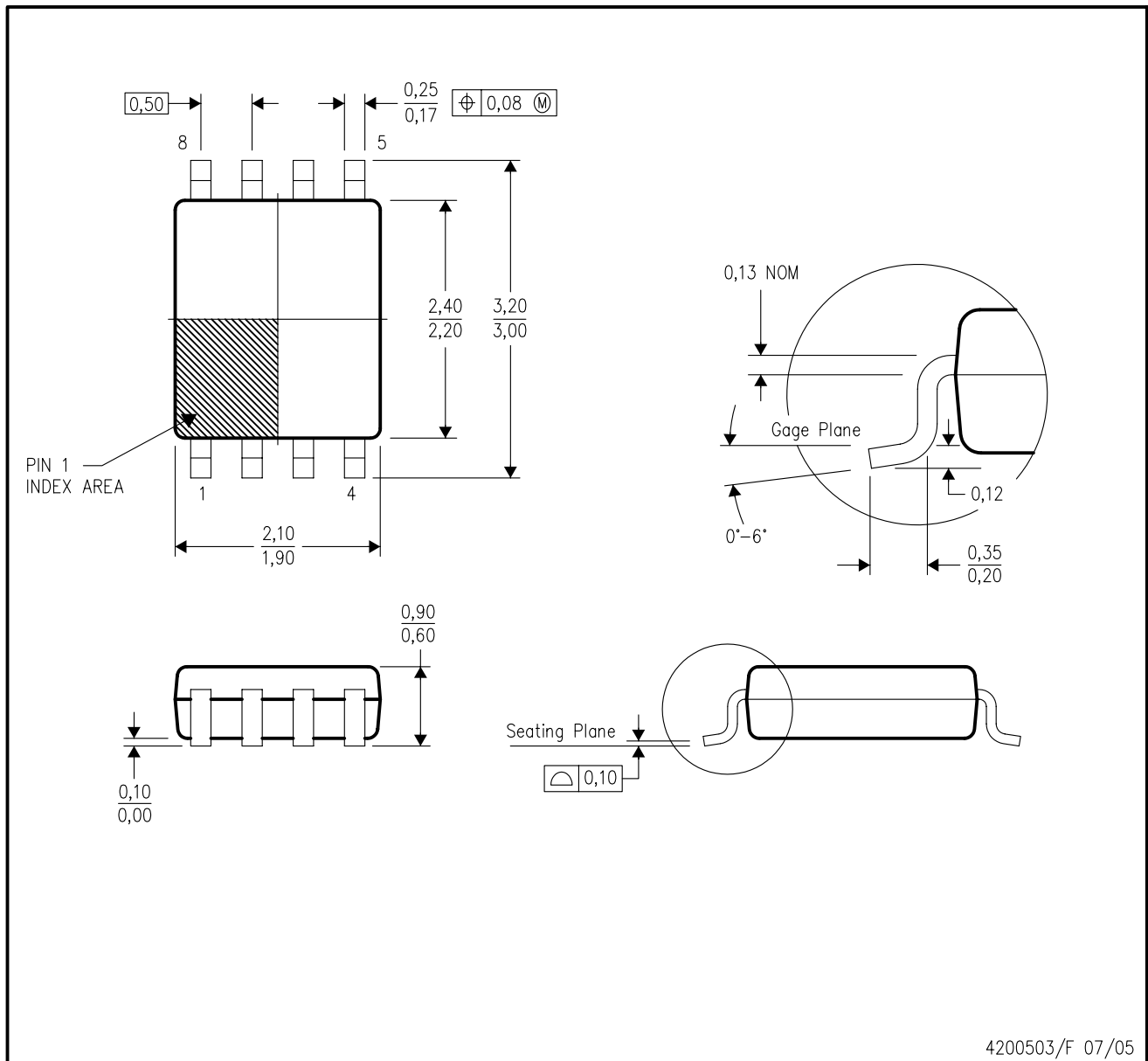

- NOTES:
- A. All linear dimensions are in millimeters.
  - B. This drawing is subject to change without notice.
  - C. Body dimensions do not include mold flash or protrusion. Mold flash and protrusion shall not exceed 0.15 per side.
  - D. Falls within JEDEC MO-187 variation CA.

DCU (S-PDSO-G8)

PLASTIC SMALL OUTLINE PACKAGE (DIE DOWN)

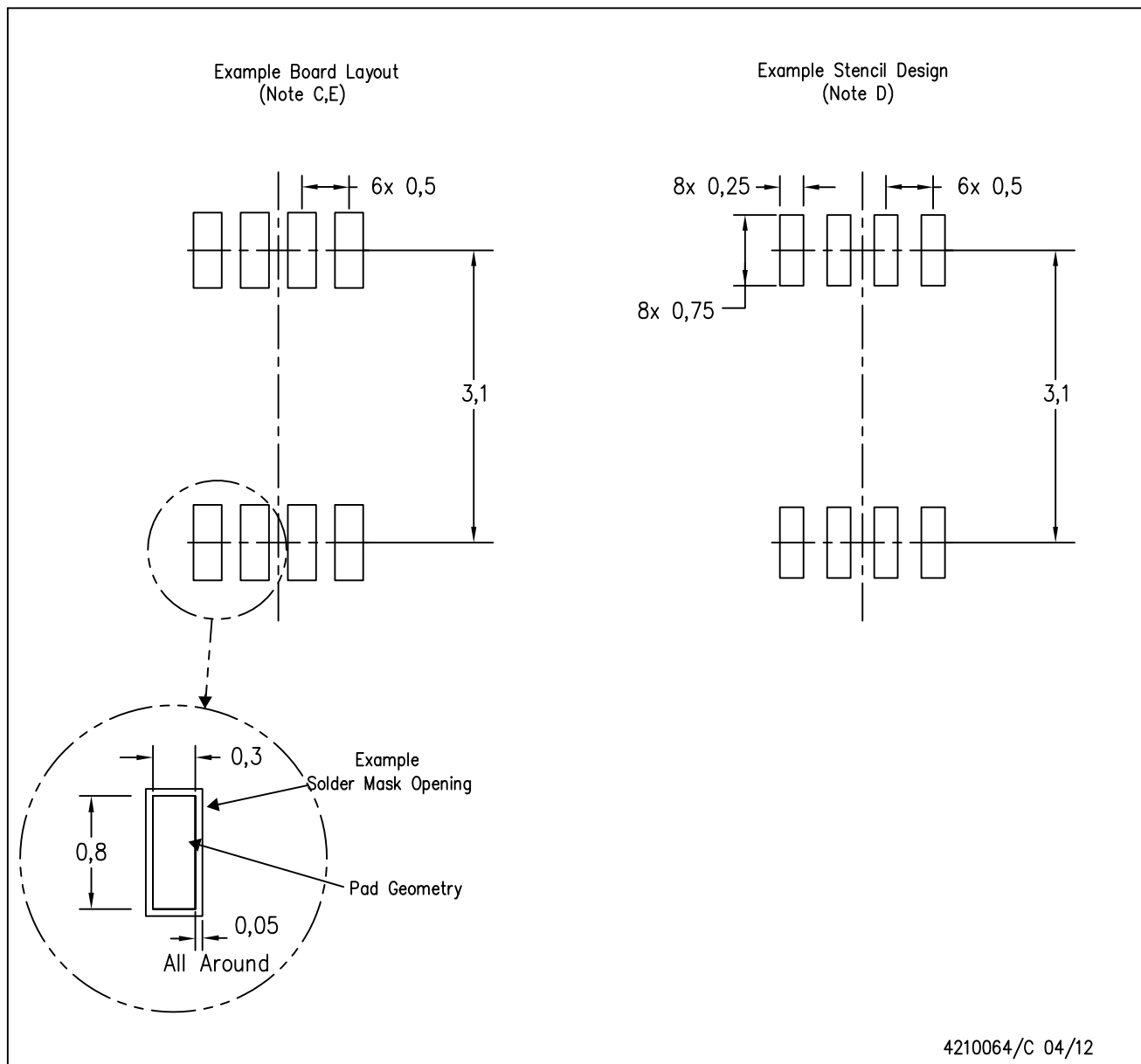

- NOTES:
- A. All linear dimensions are in millimeters.
  - B. This drawing is subject to change without notice.
  - C. Publication IPC-7351 is recommended for alternate designs.
  - D. Laser cutting apertures with trapezoidal walls and also rounding corners will offer better paste release. Customers should contact their board assembly site for stencil design recommendations. Refer to IPC-7525 for other stencil recommendations.
  - E. Customers should contact their board fabrication site for solder mask tolerances between and around signal pads.

## IMPORTANT NOTICE

Texas Instruments Incorporated (TI) reserves the right to make corrections, enhancements, improvements and other changes to its semiconductor products and services per JESD46, latest issue, and to discontinue any product or service per JESD48, latest issue. Buyers should obtain the latest relevant information before placing orders and should verify that such information is current and complete.

TI's published terms of sale for semiconductor products (<http://www.ti.com/sc/docs/stdterms.htm>) apply to the sale of packaged integrated circuit products that TI has qualified and released to market. Additional terms may apply to the use or sale of other types of TI products and services.

Reproduction of significant portions of TI information in TI data sheets is permissible only if reproduction is without alteration and is accompanied by all associated warranties, conditions, limitations, and notices. TI is not responsible or liable for such reproduced documentation. Information of third parties may be subject to additional restrictions. Resale of TI products or services with statements different from or beyond the parameters stated by TI for that product or service voids all express and any implied warranties for the associated TI product or service and is an unfair and deceptive business practice. TI is not responsible or liable for any such statements.

Buyers and others who are developing systems that incorporate TI products (collectively, "Designers") understand and agree that Designers remain responsible for using their independent analysis, evaluation and judgment in designing their applications and that Designers have full and exclusive responsibility to assure the safety of Designers' applications and compliance of their applications (and of all TI products used in or for Designers' applications) with all applicable regulations, laws and other applicable requirements. Designer represents that, with respect to their applications, Designer has all the necessary expertise to create and implement safeguards that (1) anticipate dangerous consequences of failures, (2) monitor failures and their consequences, and (3) lessen the likelihood of failures that might cause harm and take appropriate actions. Designer agrees that prior to using or distributing any applications that include TI products, Designer will thoroughly test such applications and the functionality of such TI products as used in such applications.

TI's provision of technical, application or other design advice, quality characterization, reliability data or other services or information, including, but not limited to, reference designs and materials relating to evaluation modules, (collectively, "TI Resources") are intended to assist designers who are developing applications that incorporate TI products; by downloading, accessing or using TI Resources in any way, Designer (individually or, if Designer is acting on behalf of a company, Designer's company) agrees to use any particular TI Resource solely for this purpose and subject to the terms of this Notice.

TI's provision of TI Resources does not expand or otherwise alter TI's applicable published warranties or warranty disclaimers for TI products, and no additional obligations or liabilities arise from TI providing such TI Resources. TI reserves the right to make corrections, enhancements, improvements and other changes to its TI Resources. TI has not conducted any testing other than that specifically described in the published documentation for a particular TI Resource.

Designer is authorized to use, copy and modify any individual TI Resource only in connection with the development of applications that include the TI product(s) identified in such TI Resource. NO OTHER LICENSE, EXPRESS OR IMPLIED, BY ESTOPPEL OR OTHERWISE TO ANY OTHER TI INTELLECTUAL PROPERTY RIGHT, AND NO LICENSE TO ANY TECHNOLOGY OR INTELLECTUAL PROPERTY RIGHT OF TI OR ANY THIRD PARTY IS GRANTED HEREIN, including but not limited to any patent right, copyright, mask work right, or other intellectual property right relating to any combination, machine, or process in which TI products or services are used. Information regarding or referencing third-party products or services does not constitute a license to use such products or services, or a warranty or endorsement thereof. Use of TI Resources may require a license from a third party under the patents or other intellectual property of the third party, or a license from TI under the patents or other intellectual property of TI.

TI RESOURCES ARE PROVIDED "AS IS" AND WITH ALL FAULTS. TI DISCLAIMS ALL OTHER WARRANTIES OR REPRESENTATIONS, EXPRESS OR IMPLIED, REGARDING RESOURCES OR USE THEREOF, INCLUDING BUT NOT LIMITED TO ACCURACY OR COMPLETENESS, TITLE, ANY EPIDEMIC FAILURE WARRANTY AND ANY IMPLIED WARRANTIES OF MERCHANTABILITY, FITNESS FOR A PARTICULAR PURPOSE, AND NON-INFRINGEMENT OF ANY THIRD PARTY INTELLECTUAL PROPERTY RIGHTS. TI SHALL NOT BE LIABLE FOR AND SHALL NOT DEFEND OR INDEMNIFY DESIGNER AGAINST ANY CLAIM, INCLUDING BUT NOT LIMITED TO ANY INFRINGEMENT CLAIM THAT RELATES TO OR IS BASED ON ANY COMBINATION OF PRODUCTS EVEN IF DESCRIBED IN TI RESOURCES OR OTHERWISE. IN NO EVENT SHALL TI BE LIABLE FOR ANY ACTUAL, DIRECT, SPECIAL, COLLATERAL, INDIRECT, PUNITIVE, INCIDENTAL, CONSEQUENTIAL OR EXEMPLARY DAMAGES IN CONNECTION WITH OR ARISING OUT OF TI RESOURCES OR USE THEREOF, AND REGARDLESS OF WHETHER TI HAS BEEN ADVISED OF THE POSSIBILITY OF SUCH DAMAGES.

Unless TI has explicitly designated an individual product as meeting the requirements of a particular industry standard (e.g., ISO/TS 16949 and ISO 26262), TI is not responsible for any failure to meet such industry standard requirements.

Where TI specifically promotes products as facilitating functional safety or as compliant with industry functional safety standards, such products are intended to help enable customers to design and create their own applications that meet applicable functional safety standards and requirements. Using products in an application does not by itself establish any safety features in the application. Designers must ensure compliance with safety-related requirements and standards applicable to their applications. Designer may not use any TI products in life-critical medical equipment unless authorized officers of the parties have executed a special contract specifically governing such use. Life-critical medical equipment is medical equipment where failure of such equipment would cause serious bodily injury or death (e.g., life support, pacemakers, defibrillators, heart pumps, neurostimulators, and implantables). Such equipment includes, without limitation, all medical devices identified by the U.S. Food and Drug Administration as Class III devices and equivalent classifications outside the U.S.

TI may expressly designate certain products as completing a particular qualification (e.g., Q100, Military Grade, or Enhanced Product). Designers agree that it has the necessary expertise to select the product with the appropriate qualification designation for their applications and that proper product selection is at Designers' own risk. Designers are solely responsible for compliance with all legal and regulatory requirements in connection with such selection.

Designer will fully indemnify TI and its representatives against any damages, costs, losses, and/or liabilities arising out of Designer's non-compliance with the terms and provisions of this Notice.

## Looking for pricing, stock, or lifecycle information?

Click below to explore more details on WIN SOURCE:

 [View CAVC2T45TDCURQ1](#) on WIN SOURCE

 [Texas Instruments](#) Information

## Optimize Your Supply Chain with WIN SOURCE Solutions

-  Global Sourcing Solution
-  Obsolete Management
-  Cost Control Management
-  Shortage Management
-  Alternative Solution
-  Excess Inventory Management