



**THE DATASHEET OF  
EL7158ISZ-T13**



EL7158

Ultra-High Current Pin Driver

FN7349  
Rev 2.00  
May 14, 2007

The EL7158 high performance pin driver with three-state is suited to many ATE and level-shifting applications. The 12A peak drive capability makes this part an excellent choice when driving high capacitance loads.

The output pin OUT is connected to input pins VH or VL respectively, depending on the status of the IN pin. When the OE pin is active low, the output is placed in the three-state mode. The isolation of the output FETs from the power supplies enables VH and VL to be set independently, enabling level-shifting to be implemented. Related to the EL7155, the EL7158 adds a lower supply pin VS- and makes VL an isolated and independent input. This feature adds applications flexibility and improves switching response due to the increased enhancement of the output FETs.

This pin driver has improved performance over existing pin drivers. It is specifically designed to operate at voltages down to 0V across the switch elements while maintaining good speed and ON-resistance characteristics.

Available in the 8 Ld SOIC package, the EL7158 is specified for operation over the full -40°C to +85°C temperature range.

**Pinout**

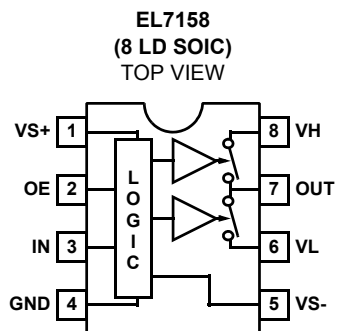

**Features**

- Clocking speeds up to 40MHz
- 12ns  $t_R/t_F$  at 2000pF  $C_{LOAD}$
- 0.2ns rise and fall times mismatch
- 0.5ns  $t_{ON}-t_{OFF}$  prop delay mismatch
- 3.5pF typical input capacitance
- 12A peak drive
- Low ON-resistance of 0.5Ω
- High capacitive drive capability
- Operates from 4.5V to 12V
- Pb-free plus anneal available (RoHS compliant)

**Applications**

- ATE/burn-in testers
- Level shifting
- IGBT drivers
- CCD drivers

**Ordering Information**

PART NUMBER	PART MARKING	PACKAGE	TAPE & REEL	PKG. DWG. #
EL7158IS	7158IS	8 Ld SOIC	-	MDP0027
EL7158IS-T7	7158IS	8 Ld SOIC	7"	MDP0027
EL7158IS-T13	7158IS	8 Ld SOIC	13"	MDP0027
EL7158ISZ (Note)	7158ISZ	8 Ld SOIC (Pb-free)	-	MDP0027
EL7158ISZ-T7 (Note)	7158ISZ	8 Ld SOIC (Pb-free)	7"	MDP0027
EL7158ISZ-T13 (Note)	7158ISZ	8 Ld SOIC (Pb-free)	13"	MDP0027

NOTE: Intersil Pb-free products employ special Pb-free material sets; molding compounds/die attach materials and 100% matte tin plate termination finish, which is compatible with both SnPb and Pb-free soldering operations. Intersil Pb-free products are MSL classified at Pb-free peak reflow temperatures that meet or exceed the Pb-free requirements of IPC/JEDEC J Std-020B.

**Absolute Maximum Ratings** ( $T_A = +25^\circ\text{C}$ )

Supply Voltage ( $V_{S+}$ to $V_{S-}$ )	+18V
Input Voltage	$V_{S-} - 0.3\text{V}$ , $V_{S+} + 0.3\text{V}$
Continuous Output Current	500mA

**Thermal Information**

Storage Temperature Range	-65°C to +150°C
Ambient operating Temperature	-40°C to +85°C
Operating Junction Temperature	+125°C
Power Dissipation	see curves
Pb-free reflow profile	see link below <a href="http://www.intersil.com/pbfree/Pb-FreeReflow.asp">http://www.intersil.com/pbfree/Pb-FreeReflow.asp</a>

**CAUTION:** Stresses above those listed in "Absolute Maximum Ratings" may cause permanent damage to the device. This is a stress only rating and operation of the device at these or any other conditions above those indicated in the operational sections of this specification is not implied.

**IMPORTANT NOTE:** All parameters having Min/Max specifications are guaranteed. Typical values are for information purposes only. Unless otherwise noted, all tests are at the specified temperature and are pulsed tests, therefore:  $T_J = T_C = T_A$

**Electrical Specifications**  $V_{S+} = +12\text{V}$ ,  $V_H = +12\text{V}$ ,  $V_L = 0\text{V}$ ,  $V_{S-} = 0\text{V}$ ,  $T_A = +25^\circ\text{C}$ , unless otherwise specified.

PARAMETER	DESCRIPTION	CONDITION	MIN	TYP	MAX	UNIT
<b>INPUT</b>						
$V_{IH}$	Logic '1' Input Voltage		2.4			V
$I_{IH}$	Logic '1' Input Current	$V_{IH} = V_{S+}$		0.1	10	$\mu\text{A}$
$V_{IL}$	Logic '0' Input Voltage				0.8	V
$I_{IL}$	Logic '0' Input Current	$V_{IL} = 0\text{V}$		0.1	10	$\mu\text{A}$
$C_{IN}$	Input Capacitance			3.5		pF
$R_{IN}$	Input Resistance			50		M $\Omega$
<b>OUTPUT</b>						
$R_{OVH}$	ON-Resistance $V_H$ to OUT	$I_{OUT} = -500\text{mA}$		0.5	1	$\Omega$
$R_{OVL}$	ON-Resistance $V_L$ to OUT	$I_{OUT} = +500\text{mA}$		0.5	1	$\Omega$
$I_{OUT}$	Output Leakage Current	$OE = 0\text{V}$ , $OUT = V_H/V_L$		0.1	10	$\mu\text{A}$
$I_{PK}$	Peak Output Current (linear resistive operation)	Source		12		A
		Sink		12		A
$I_{DC}$	Continuous Output Current	Source/Sink	500			mA
<b>POWER SUPPLY</b>						
$I_S$	Power Supply Current	Inputs = $V_{S+}$		1.3	3	mA
$I_{VH}$	Off Leakage at $V_H$ and $V_L$	$V_H, V_L = 0\text{V}$		4	10	$\mu\text{A}$
<b>SWITCHING CHARACTERISTICS</b>						
$t_R$	Rise Time	$C_L = 2000\text{pF}$		12.0		ns
$t_F$	Fall Time	$C_L = 2000\text{pF}$		12.2		ns
$t_{RF\Delta}$	$t_R, t_F$ Mismatch	$C_L = 2000\text{pF}$		0.2		ns
$t_{d-1}$	Turn-Off Delay Time	$C_L = 2000\text{pF}$		22.5		ns
$t_{d-2}$	Turn-On Delay Time	$C_L = 2000\text{pF}$		22.0		ns
$t_{d\Delta}$	$t_{d-1} - t_{d-2}$ Mismatch	$C_L = 2000\text{pF}$		0.5		ns
$t_{d-3}$	Three-State Delay Enable			22		ns
$t_{d-4}$	Three-State Delay Disable			22		ns
SR+	$V_{OUT+}$ Slew Rate	$R_{LOAD} = 6\Omega$		800		V/ $\mu\text{s}$
SR-	$V_{OUT-}$ Slew Rate	$R_{LOAD} = 6\Omega$		800		V/ $\mu\text{s}$

**Electrical Specifications**  $V_{S+} = +12V$ ,  $V_H = +1.2V$ ,  $V_L = 0V$ ,  $V_{S-} = 0V$ ,  $T_A = +25^\circ C$ , unless otherwise specified. (Continued)

PARAMETER	DESCRIPTION	CONDITION	MIN	TYP	MAX	UNIT
<b>INPUT</b>						
$V_{IH}$	Logic '1' Input Voltage		2.0			V
$I_{IH}$	Logic '1' Input Current	$V_{IH} = V_{S+}$		0.1	10	$\mu A$
$V_{IL}$	Logic '0' Input Voltage				0.8	V
$I_{IL}$	Logic '0' Input Current	$V_{IL} = 0V$		0.1	10	$\mu A$
$C_{IN}$	Input Capacitance			3.5		pF
$R_{IN}$	Input Resistance			50		$M\Omega$
<b>OUTPUT</b>						
$R_{OVH}$	ON-Resistance $V_H$ to OUT	$I_{OUT} = -500mA$		0.5	1	$\Omega$
$R_{OVL}$	ON-Resistance $V_L$ to OUT	$I_{OUT} = +500mA$		0.5	1	$\Omega$
$I_{OUT}$	Output Leakage Current	$OE = 0V$ , $OUT = V_H/V_L$		0.1	10	$\mu A$
$I_{PK}$	Peak Output Current (linear resistive operation)	Source		1.2		A
		Sink		1.2		A
$I_{DC}$	Continuous Output Current	Source/Sink	500			mA
<b>POWER SUPPLY</b>						
$I_S$	Power Supply Current	Inputs = $V_{S+}$		1	2.5	mA
$V_H$	Off Leakage at $V_H$ and $V_L$	$V_H, V_L = 0V$		4	10	$\mu A$
<b>SWITCHING CHARACTERISTICS</b>						
$t_R$	Rise Time	$C_L = 2000pF$		11		ns
$t_F$	Fall Time	$C_L = 2000pF$		11		ns
$t_{RF\Delta}$	$t_R, t_F$ Mismatch	$C_L = 2000pF$		0		ns
$t_{d-1}$	Turn-Off Delay Time	$C_L = 2000pF$		20.5		ns
$t_{d-2}$	Turn-On Delay Time	$C_L = 2000pF$		20.0		ns
$t_{d\Delta}$	$t_{d-1} - t_{d-2}$ Mismatch	$C_L = 2000pF$		0.5		ns
$t_{d-3}$	Three-State Delay Enable			20		ns
$t_{d-4}$	Three-State Delay Disable			20		ns
SR+	$V_{OUT+}$ Slew Rate	$R_{LOAD} = 6\Omega$		80		V/ $\mu s$
SR-	$V_{OUT-}$ Slew Rate	$R_{LOAD} = 6\Omega$		80		V/ $\mu s$

Typical Performance Curves

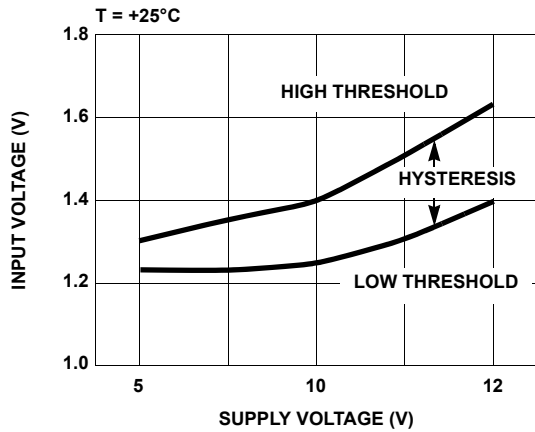

FIGURE 1. INPUT THRESHOLD vs SUPPLY VOLTAGE

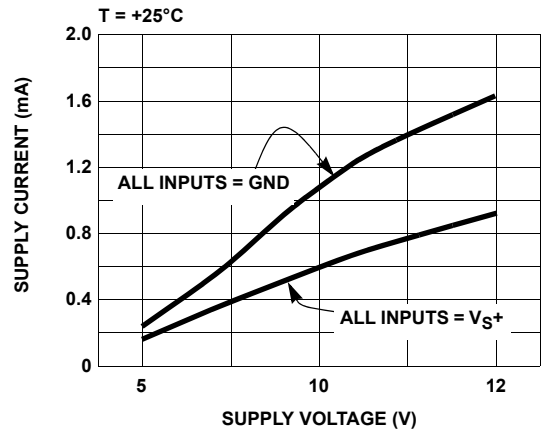

FIGURE 2. QUIESCENT SUPPLY CURRENT vs SUPPLY VOLTAGE

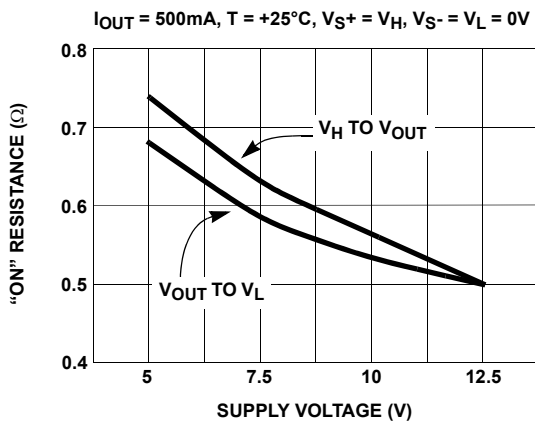

FIGURE 3. "ON"-RESISTANCE vs SUPPLY VOLTAGE ( $V_{S+}$ )

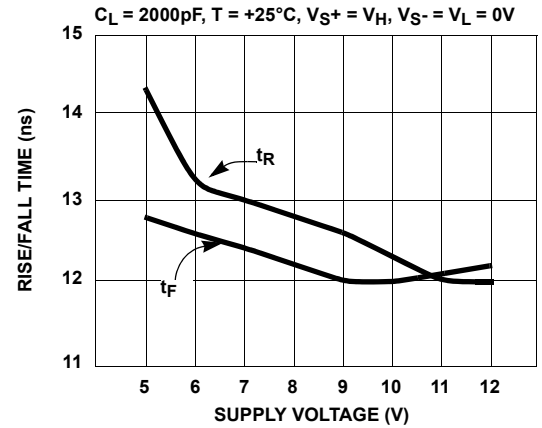

FIGURE 4. RISE/FALL TIME vs SUPPLY VOLTAGE

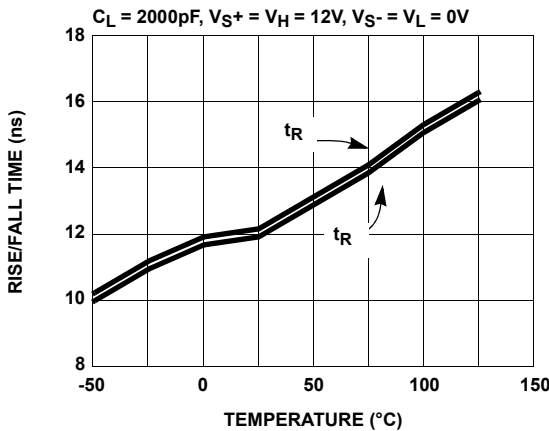

FIGURE 5. RISE/FALL TIME vs TEMPERATURE

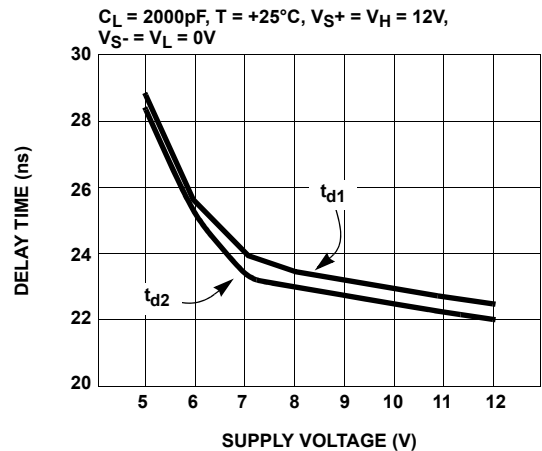

FIGURE 6. PROPAGATION DELAY vs SUPPLY VOLTAGE

**Typical Performance Curves** (Continued)

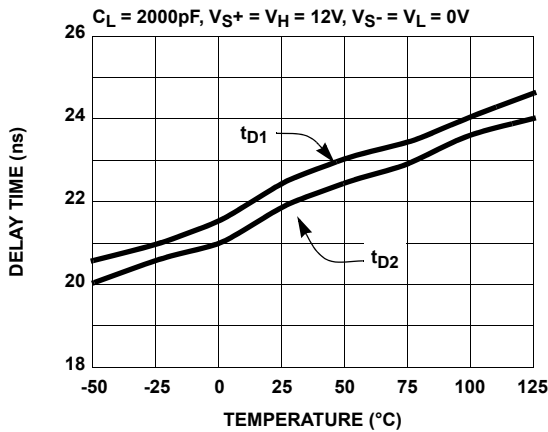

FIGURE 7. PROPAGATION DELAY vs TEMPERATURE

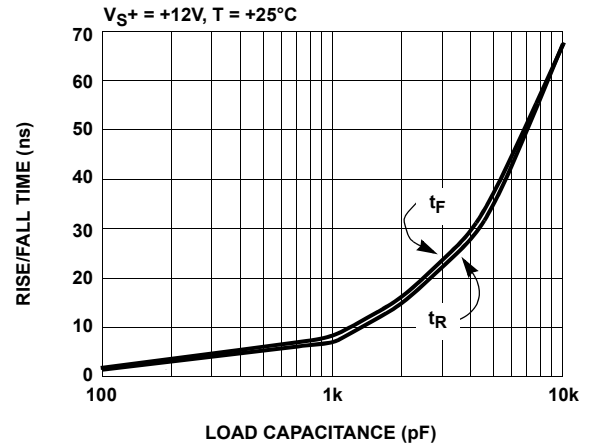

FIGURE 8. RISE/FALL TIME vs LOAD CAPACITANCE

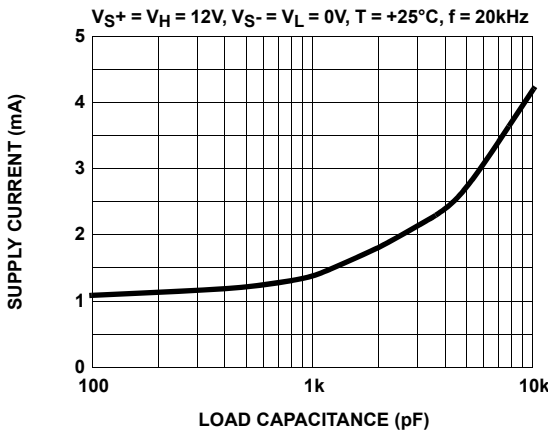

FIGURE 9. SUPPLY CURRENT vs LOAD CAPACITANCE

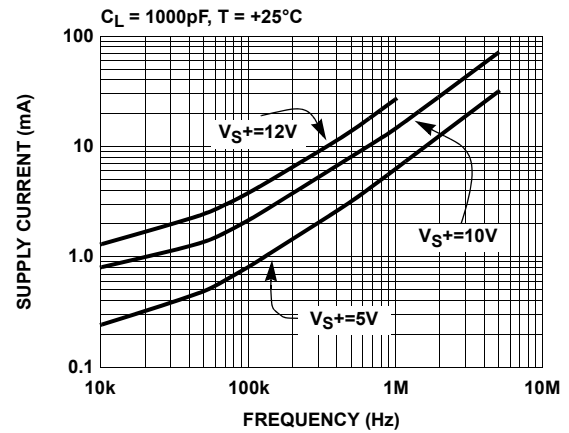

FIGURE 10. SUPPLY CURRENT vs FREQUENCY

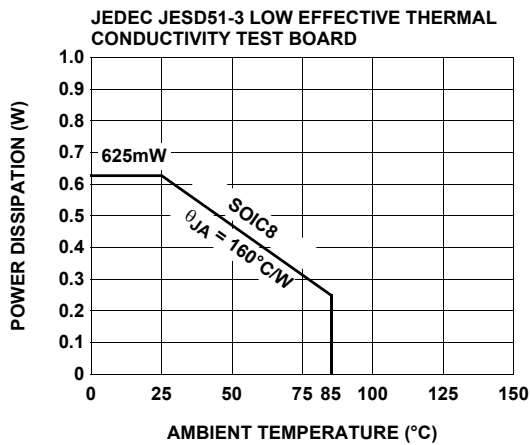

FIGURE 11. PACKAGE POWER DISSIPATION vs AMBIENT TEMPERATURE

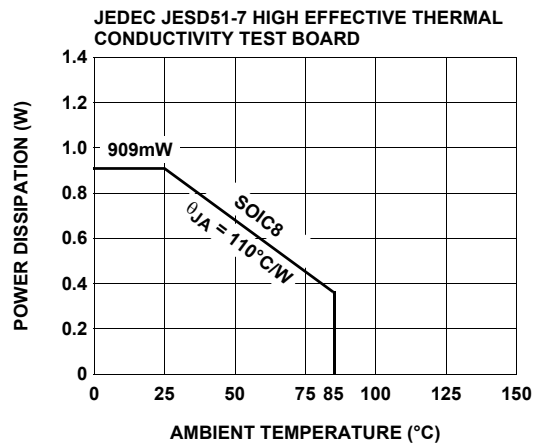

FIGURE 12. PACKAGE POWER DISSIPATION vs AMBIENT TEMPERATURE

TABLE 1. TRUTH TABLE

OE	IN	OUT
0	0	Three-State
0	1	Three-State
1	0	V <sub>H</sub>
1	1	V <sub>L</sub>

TABLE 2. OPERATING VOLTAGE RANGE

PIN	MIN	MAX
V <sub>S-</sub> to GND	-5	0
V <sub>S+</sub> to V <sub>S-</sub>	5	18
V <sub>H</sub> to V <sub>L</sub>	0	12
V <sub>S+</sub> to V <sub>H</sub>	0	12
V <sub>S+</sub> to GND	5	12
V <sub>L</sub> to V <sub>S-</sub>	0	12
Three-State Output	V <sub>L</sub>	V <sub>H</sub>

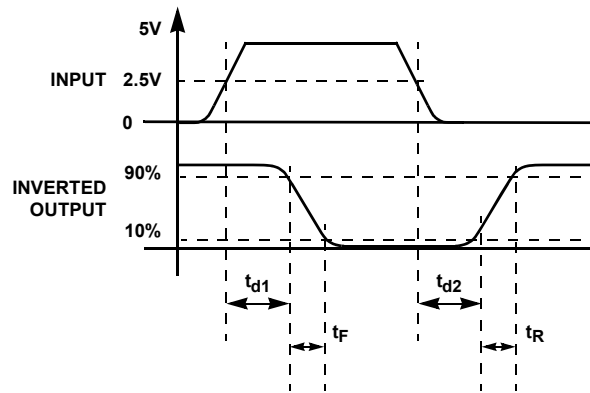

FIGURE 13. TIMING DIAGRAM

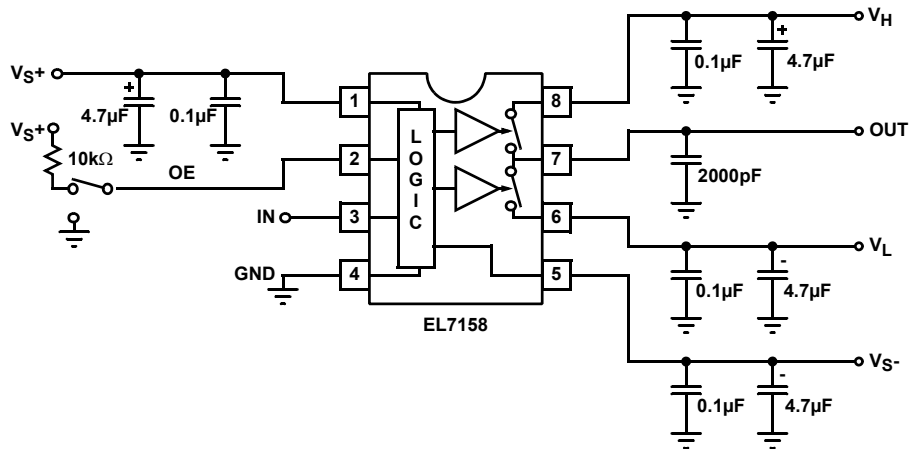

FIGURE 14. STANDARD TEST CONFIGURATION

© Copyright Intersil Americas LLC 2003-2007. All Rights Reserved.  
 All trademarks and registered trademarks are the property of their respective owners.

For additional products, see [www.intersil.com/en/products.html](http://www.intersil.com/en/products.html)

Intersil products are manufactured, assembled and tested utilizing ISO9001 quality systems as noted in the quality certifications found at [www.intersil.com/en/support/qualandreliability.html](http://www.intersil.com/en/support/qualandreliability.html)

*Intersil products are sold by description only. Intersil may modify the circuit design and/or specifications of products at any time without notice, provided that such modification does not, in Intersil's sole judgment, affect the form, fit or function of the product. Accordingly, the reader is cautioned to verify that datasheets are current before placing orders. Information furnished by Intersil is believed to be accurate and reliable. However, no responsibility is assumed by Intersil or its subsidiaries for its use; nor for any infringements of patents or other rights of third parties which may result from its use. No license is granted by implication or otherwise under any patent or patent rights of Intersil or its subsidiaries.*

For information regarding Intersil Corporation and its products, see [www.intersil.com](http://www.intersil.com)

**Pin Descriptions**

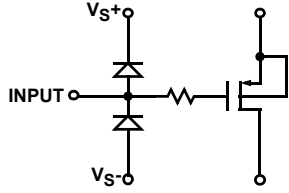
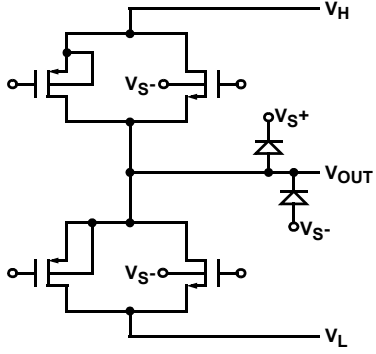
PIN	NAME	FUNCTION	EQUIVALENT CIRCUIT
1	VS+	Positive Supply Voltage	
2	OE	Output Enable	 <p style="text-align: center;">Circuit 1</p>
3	IN	Input	Reference Circuit 1
4	GND	Ground	
5	VS-	Negative Supply Voltage	
6	VL	Lower Output Voltage	
7	OUT	Output	 <p style="text-align: center;">Circuit 2</p>
8	VH	High Output Voltage	

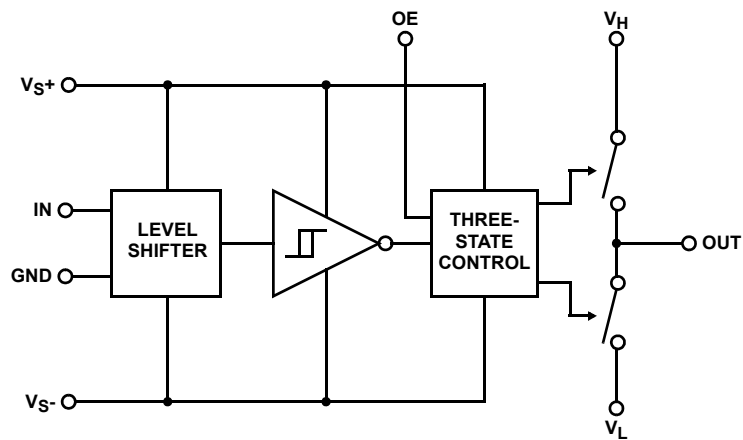

FIGURE 15. BLOCK DIAGRAM

## Applications Information

### Product Description

The EL7158 is a high performance 40MHz pin driver. It contains two analog switches connecting VH and VL to OUT. Depending on the value of the IN pin, one of the two switches will be closed and the other switch open. An output enable (OE) is also supplied which opens both switches simultaneously.

Due to the topology of the EL7158, both the VH and VL pins can be connected to any voltage between the VS+ and VS- pins, but VH must be greater than VL in order to prevent turning on the body diode at the output stage.

### Three-State Operation

When the OE pin is low, the output is three-state (floating). The output voltage is the parasitic capacitance's voltage. It can be any voltage between VH and VL, depending on the previous state. At three-state, the output voltage can be pushed to any voltage between VH and VL. The output voltage can't be pushed higher than VH or lower than VL since the body diode at the output stage will turn on.

### Supply Voltage Range and Input Compatibility

The EL7158 is designed for operation on supplies from 5V to 18V (4.5V to 18V maximum). Table 2 shows the specifications for the relationship between the VS+, VS-, VH, VL, and GND pins.

All input pins are compatible with both 3V and 5V CMOS signals. With a positive supply (VS+) of 5V, the EL7158 is also compatible with TTL inputs.

### Power Supply Bypassing

When using the EL7158, it is very important to use adequate power supply bypassing. The high switching currents developed by the EL7158 necessitate the use of a bypass capacitor between the supplies (VS+ and VS-) and GND pins. It is recommended that a 2.2μF tantalum capacitor be used in parallel with a 0.1μF low-inductance ceramic MLC capacitor. These should be placed as close to the supply pins as possible. It is also recommended that the VH and VL pins have some level of bypassing, especially if the EL7158 is driving highly capacitive loads.

### Power Dissipation Calculation

When switching at high speeds, or driving heavy loads, the EL7158 drive capability is limited by the rise in die temperature brought about by internal power dissipation. For reliable operation die temperature must be kept below TJMAX (+125°C). It is necessary to calculate the power dissipation for a given application prior to selecting the package type.

Power dissipation may be calculated:

$$PD = (V_S \times I_S) + (C_{INT} \times V_S^2 \times f) + (C_L \times V_{OUT}^2 \times f) \quad (\text{EQ. 1})$$

where:

VS is the total power supply to the EL7158 (from VS+ to GND)

VOUT is the swing on the output (VH - VL)

CL is the load capacitance

CINT is the internal load capacitance (100pF max)

IS is the quiescent supply current (3mA max)

f is frequency

Having obtained the application's power dissipation, a maximum package thermal coefficient may be determined, to maintain the internal die temperature below TJMAX:

$$\theta_{JA} = \frac{T_{JMAX} - T_{MAX}}{PD} \quad (\text{EQ. 2})$$

where:

TJMAX is the maximum junction temperature (+125°C)

TMAX is the maximum operating temperature

PD is the power dissipation calculated above

θJA thermal resistance on junction to ambient

θJA is 160°C/W for the SOIC8 package when using a standard JEDEC JESD51-3 single-layer test board. If TJMAX is greater than +125°C when calculated using Equation 2, then one of the following actions must be taken:

Reduce θJA the system by designing more heat-sinking into the PCB (as compared to the standard JEDEC JESD51-3)

De-rate the application either by reducing the switching frequency, the capacitive load, or the maximum operating (ambient) temperature (TMAX)

**Small Outline Package Family (SO)**

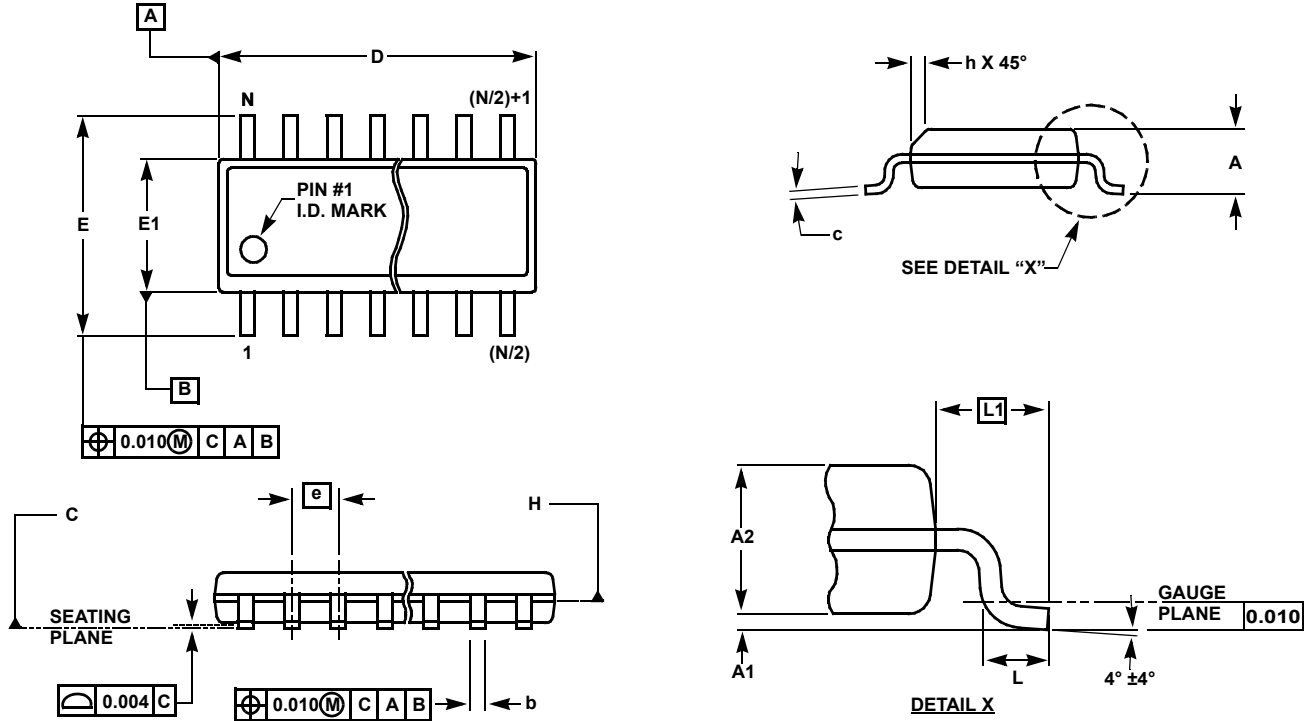

**MDP0027**

**SMALL OUTLINE PACKAGE FAMILY (SO)**

SYMBOL	INCHES							TOLERANCE	NOTES
	SO-8	SO-14	SO16 (0.150")	SO16 (0.300") (SOL-16)	SO20 (SOL-20)	SO24 (SOL-24)	SO28 (SOL-28)		
A	0.068	0.068	0.068	0.104	0.104	0.104	0.104	MAX	-
A1	0.006	0.006	0.006	0.007	0.007	0.007	0.007	±0.003	-
A2	0.057	0.057	0.057	0.092	0.092	0.092	0.092	±0.002	-
b	0.017	0.017	0.017	0.017	0.017	0.017	0.017	±0.003	-
c	0.009	0.009	0.009	0.011	0.011	0.011	0.011	±0.001	-
D	0.193	0.341	0.390	0.406	0.504	0.606	0.704	±0.004	1, 3
E	0.236	0.236	0.236	0.406	0.406	0.406	0.406	±0.008	-
E1	0.154	0.154	0.154	0.295	0.295	0.295	0.295	±0.004	2, 3
e	0.050	0.050	0.050	0.050	0.050	0.050	0.050	Basic	-
L	0.025	0.025	0.025	0.030	0.030	0.030	0.030	±0.009	-
L1	0.041	0.041	0.041	0.056	0.056	0.056	0.056	Basic	-
h	0.013	0.013	0.013	0.020	0.020	0.020	0.020	Reference	-
N	8	14	16	16	20	24	28	Reference	-



Rev. M 2/07

**NOTES:**

1. Plastic or metal protrusions of 0.006" maximum per side are not included.
2. Plastic interlead protrusions of 0.010" maximum per side are not included.
3. Dimensions "D" and "E1" are measured at Datum Plane "H".
4. Dimensioning and tolerancing per ASME Y14.5M-1994

## Looking for pricing, stock, or lifecycle information?

Click below to explore more details on WIN SOURCE:

-  [View EL7158ISZ-T13 on WIN SOURCE](#)
-  [Renesas Electronics America](#) Information

## Optimize Your Supply Chain with WIN SOURCE Solutions

-  Global Sourcing Solution
-  Obsolete Management
-  Cost Control Management
-  Shortage Management
-  Alternative Solution
-  Excess Inventory Management