



**THE DATASHEET OF
SCPE-G-10.00-D-O-NP**



STYLE
 -01: PANEL MOUNT DUST CAP
 -02: CABLE DUST CAP
 -03: USB FLASH DRIVE COVER



DO NOT
SCALE FROM
THIS PRINT

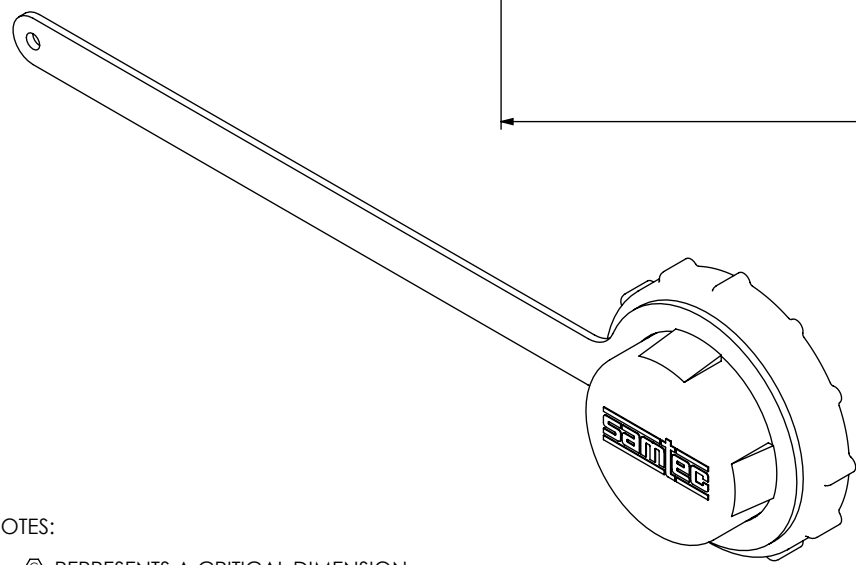
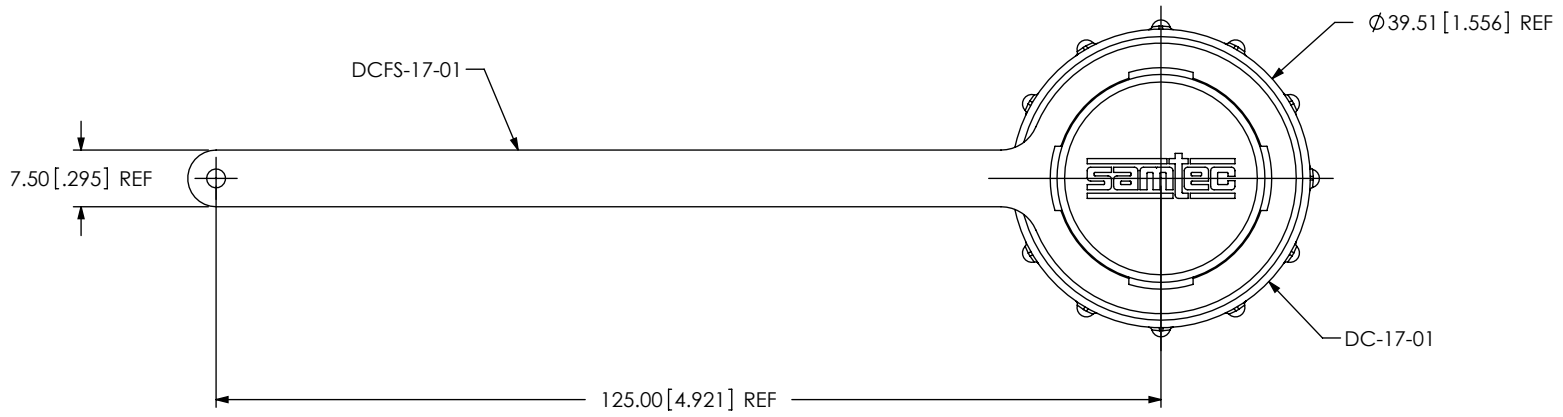



FIG 1
DCA-17-01 SHOWN

- NOTES:
1. ⊗ REPRESENTS A CRITICAL DIMENSION.
 2. VENDOR TO ASSEMBLE PARTS.
 3. COMPONENTS MUST BE PRESSED DOWN BELOW SNAPS.
 4. DCA-17-03 WILL ACCOMODATE USB DEVICE WITH DIMENSIONS 80.00mm X 13.30mm X 20.25mm.
 5. TORQUE SPECIFICATION FOR SCN-17-04 IS 12 IN-LB.
 6. MIN BEND RADIUS: 6.00 [.24]

UNLESS OTHERWISE SPECIFIED, DIMENSIONS ARE IN MILLIMETERS. TOLERANCES ARE: DECIMALS ANGLES .X: ± 0.3 [.01] 2° .XX: ± 0.13 [.005] .XXX: ± 0.051 [.0020]	PROPRIETARY NOTE THIS DOCUMENT CONTAINS INFORMATION CONFIDENTIAL AND PROPRIETARY TO SAMTEC, INC. AND SHALL NOT BE REPRODUCED OR TRANSFERRED TO OTHER DOCUMENTS OR DISCLOSED TO OTHERS OR USED FOR ANY PURPOSE OTHER THAN THAT WHICH IT WAS OBTAINED WITHOUT THE EXPRESSED WRITTEN CONSENT OF SAMTEC, INC.		
		520 PARK EAST BLVD, NEW ALBANY, IN 47150 PHONE: 812-944-6733 FAX: 812-948-5047 e-Mail: info@SAMTEC.com code: 55322	
MATERIAL: DO NOT SCALE DRAWING SHEET SCALE: 1:1 STRAP: LDPE CAP: PA66 O-RING: SILICONE		DESCRIPTION: DUST CAP ASSEMBLY	
		DWG. NO. DCA-17-XX	
		BY: CHAD F 11/22/2004	SHEET 1 OF 3

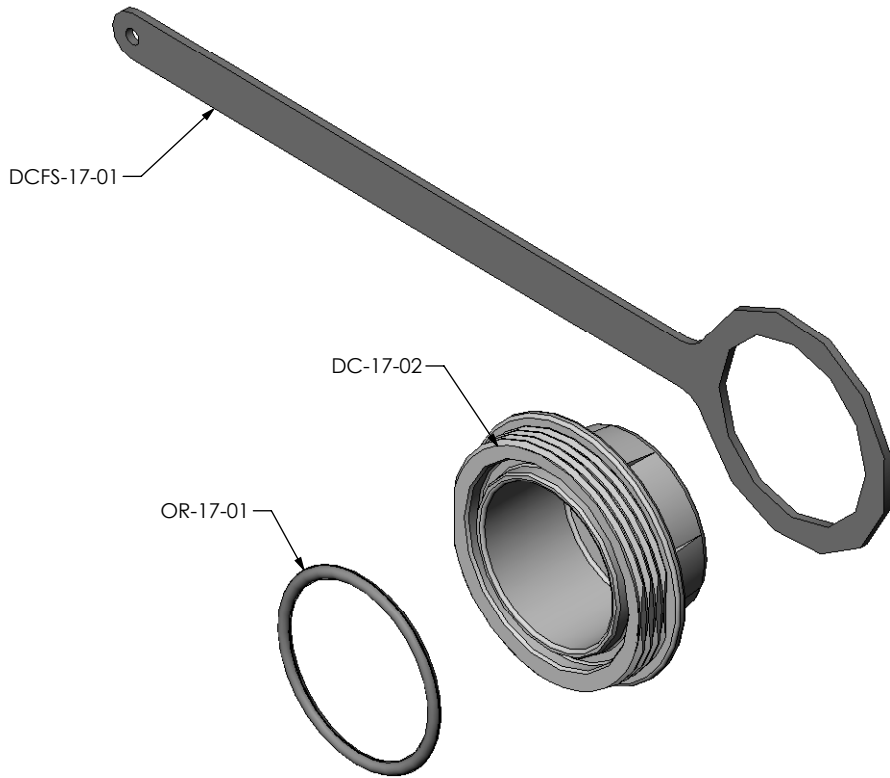
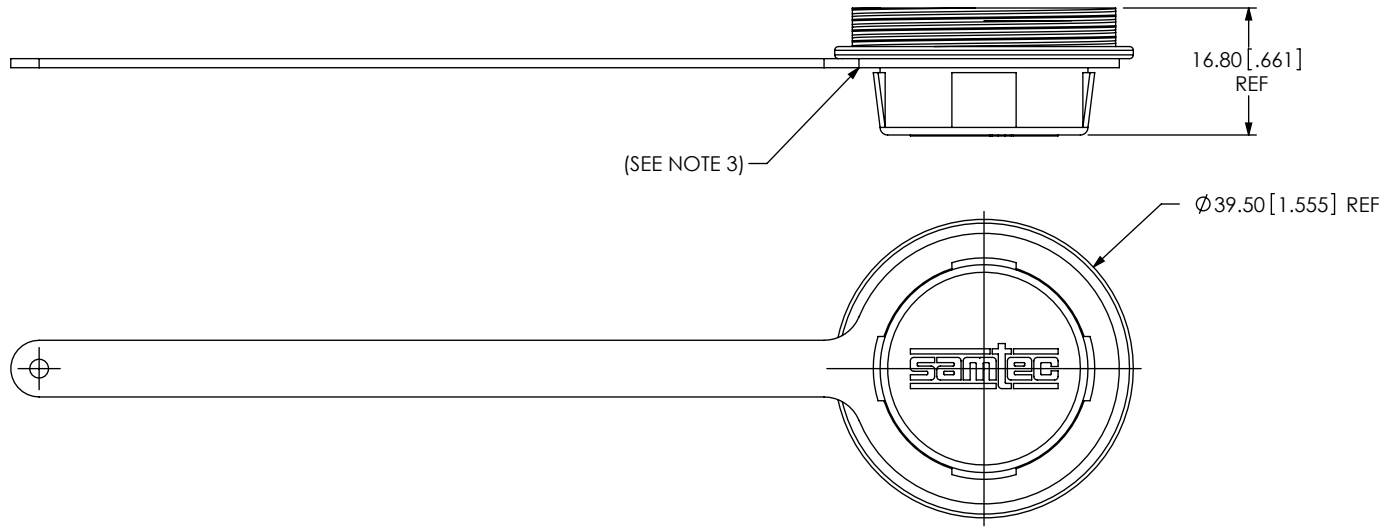



FIG 2
DCA-17-02 SHOWN
(SAME AS FIG 1, UNLESS OTHERWISE STATED)

<p>PROPRIETARY NOTE THIS DOCUMENT CONTAINS INFORMATION CONFIDENTIAL AND PROPRIETARY TO SAMTEC, INC. AND SHALL NOT BE REPRODUCED OR TRANSFERRED TO OTHER DOCUMENTS OR DISCLOSED TO OTHERS OR USED FOR ANY PURPOSE OTHER THAN THAT WHICH IT WAS OBTAINED WITHOUT THE EXPRESSED WRITTEN CONSENT OF SAMTEC, INC.</p> <p>DO NOT SCALE DRAWING</p> <p>SHEET SCALE: 1:1</p>		
	<p>520 PARK EAST BLVD., NEW ALBANY, IN 47150 PHONE: 812-944-6733 FAX: 812-948-5047 e-Mail: info@SAMTEC.com code: 55322</p>	
	<p>DESCRIPTION: DUST CAP ASSEMBLY</p>	
	<p>DWG. NO. DCA-17-XX</p>	
BY: CHAD F	11/22/2004	SHEET 2 OF 3

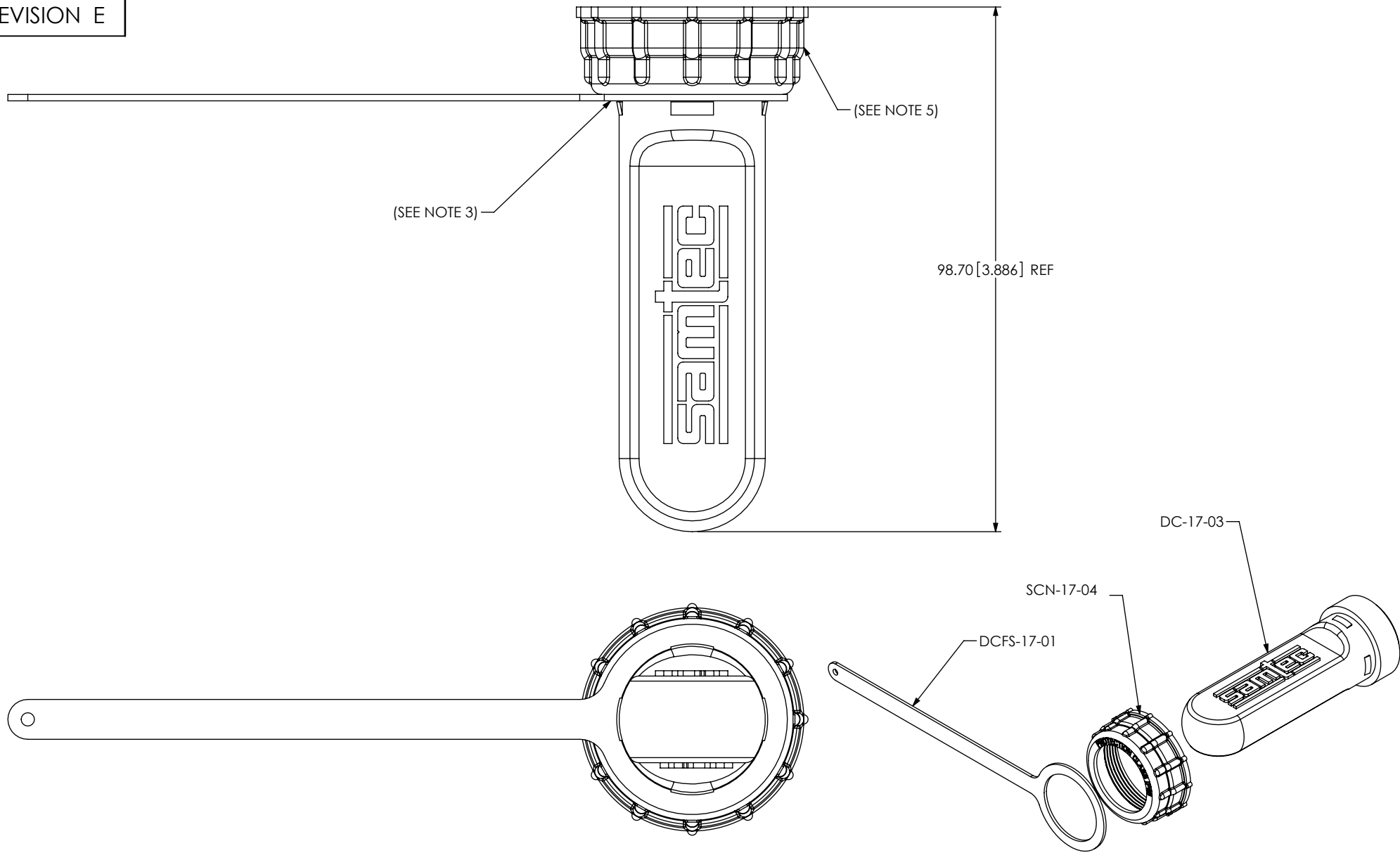





FIG 3
DCA-17-03 SHOWN
(SAME AS FIG 1, UNLESS OTHERWISE STATED)

<p>PROPRIETARY NOTE</p> <p>THIS DOCUMENT CONTAINS INFORMATION CONFIDENTIAL AND PROPRIETARY TO SAMTEC, INC. AND SHALL NOT BE REPRODUCED OR TRANSFERRED TO OTHER DOCUMENTS OR DISCLOSED TO OTHERS OR USED FOR ANY PURPOSE OTHER THAN THAT WHICH IT WAS OBTAINED WITHOUT THE EXPRESSED WRITTEN CONSENT OF SAMTEC, INC.</p> <p>DO NOT SCALE DRAWING</p> <p>SHEET SCALE: 1:2</p>		
	<p>520 PARK EAST BLVD, NEW ALBANY, IN 47150 PHONE: 812-944-6733 FAX: 812-948-5047 e-Mail: info@SAMTEC.com code: 55322</p>	
	<p>DESCRIPTION: DUST CAP ASSEMBLY</p>	
	<p>DWG. NO. DCA-17-XX</p>	
<p>BY: CHAD F</p>	<p>11/22/2004</p>	<p>SHEET 3 OF 3</p>

Looking for pricing, stock, or lifecycle information?

Click below to explore more details on WIN SOURCE:

-  [View SCPE-G-10.00-D-O-NP on WIN SOURCE](#)
-  [Samtec Inc. Information](#)

Optimize Your Supply Chain with WIN SOURCE Solutions

-  Global Sourcing Solution
-  Obsolete Management
-  Cost Control Management
-  Shortage Management
-  Alternative Solution
-  Excess Inventory Management