



**THE DATASHEET OF
E4D20120G**



E4D20120G

1200 V, 20 A Silicon Carbide Schottky Diode

Features

- 4th generation SiC merged PIN Schottky technology
- Zero reverse recovery current
- High-frequency operation
- Temperature-independent switching behavior
- AEC-Q101 qualified and PPAP capable
- Humidity resistant



TO-263-2



Package Types: TO-263-2

PN: E4D20120G

WolfSpeed, Inc. is in the process of rebranding its products and related materials pursuant to the entity name change from Cree, Inc. to WolfSpeed, Inc. During this transition period, products received may be marked with either the Cree name and/or logo or the WolfSpeed name and/or logo.

Applications

- Boost diodes in PFC or DC/DC stages
- Free wheeling diodes in inverter stages
- AC/DC converters
- Automotive and traction power conversion
- PV inverters

Benefits

- Replace bipolar with unipolar rectifiers
- Essentially no switching losses
- Higher efficiency
- Reduction of heat sink requirements
- Parallel devices without thermal runaway
- Ideal for outdoor environments

Maximum Ratings ($T_c = 25\text{ }^\circ\text{C}$ Unless Otherwise Specified)

Parameter	Symbol	Value	Unit	Test Conditions	Note
Repetitive Peak Reverse Voltage	V_{RRM}	1200	V		
DC Peak Reverse Voltage	V_R	1200			
Continuous Forward Current	I_F	56	A	$T_c = 25\text{ }^\circ\text{C}$	Fig. 3
		27		$T_c = 135\text{ }^\circ\text{C}$	
		20		$T_c = 150\text{ }^\circ\text{C}$	
Power Dissipation	P_{tot}	250	W	$T_c = 25\text{ }^\circ\text{C}$	Fig. 4
		108		$T_c = 110\text{ }^\circ\text{C}$	
Repetitive Peak Forward Surge Current	I_{FRM}	83	A	$T_c = 25\text{ }^\circ\text{C}$, $t_p = 10\text{ ms}$, Half Sine Pulse	
		47		$T_c = 110\text{ }^\circ\text{C}$, $t_p = 10\text{ ms}$, Half Sine Pulse	
Diode dV/dt Ruggedness	dV/dt	250	V/ns	$V_R = 0\text{--}960\text{ V}$	
Operating Junction and Storage Temperature	T_J, T_{stg}	-55 to +175	$^\circ\text{C}$		



Electrical Characteristics

Parameter	Symbol	Typ.	Max.	Unit	Test Conditions	Note
Forward Voltage	V_F	1.5	1.8	V	$I_F = 20 \text{ A}, T_J = 25 \text{ }^\circ\text{C}$	Fig. 1
		2.2			$I_F = 20 \text{ A}, T_J = 175 \text{ }^\circ\text{C}$	
Reverse Current	I_R	35	200	μA	$V_R = 1200 \text{ V}, T_J = 25 \text{ }^\circ\text{C}$	Fig. 2
		65			$V_R = 1200 \text{ V}, T_J = 175 \text{ }^\circ\text{C}$	
Total Capacitive Charge	Q_C	110		nC	$V_R = 800 \text{ V}, I_F = 20 \text{ A}$	Fig. 5
					$di/dt = 200 \text{ A}/\mu\text{s}$	
					$T_J = 25 \text{ }^\circ\text{C}$	
Total Capacitance	C	1474		pF	$V_R = 0 \text{ V}, T_J = 25 \text{ }^\circ\text{C}, f = 1 \text{ MHz}$	Fig. 6
		100			$V_R = 400 \text{ V}, T_J = 25 \text{ }^\circ\text{C}, f = 1 \text{ MHz}$	
		76			$V_R = 800 \text{ V}, T_J = 25 \text{ }^\circ\text{C}, f = 1 \text{ MHz}$	
Capacitance Stored Energy	E_C	33		μJ	$V_R = 800 \text{ V}$	Fig. 7

Note: This is a majority carrier diode, so there is no reverse recovery charge.

Thermal Characteristics

Parameter	Symbol	Typ.	Unit	Note
Thermal Resistance from Junction to Case	$R_{\theta JC}$	0.6	$^\circ\text{C}/\text{W}$	Fig. 8

Typical Performance

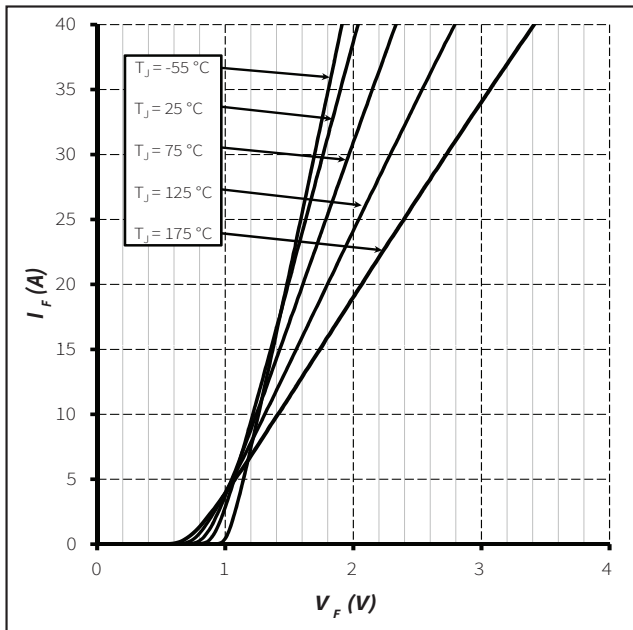

Figure 1. Forward Characteristics

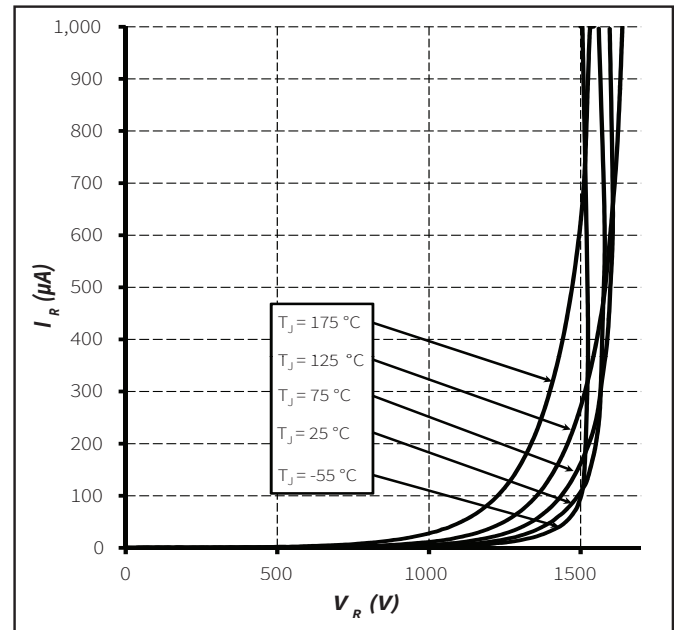

Figure 2. Reverse Characteristics



Typical Performance

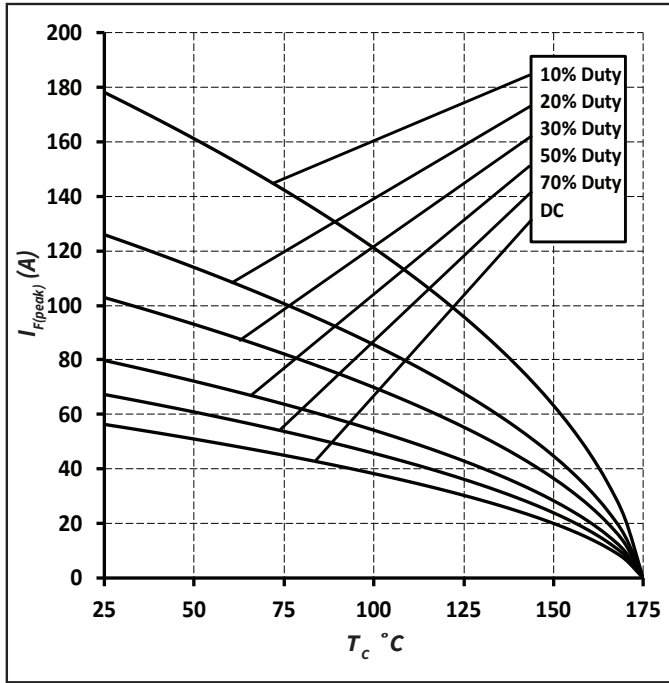

Figure 3. Current Derating

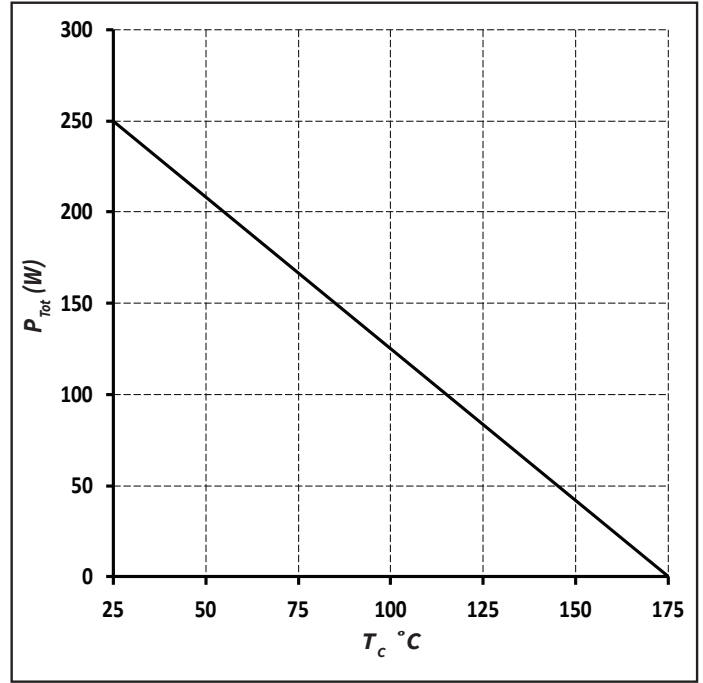

Figure 4. Power Derating

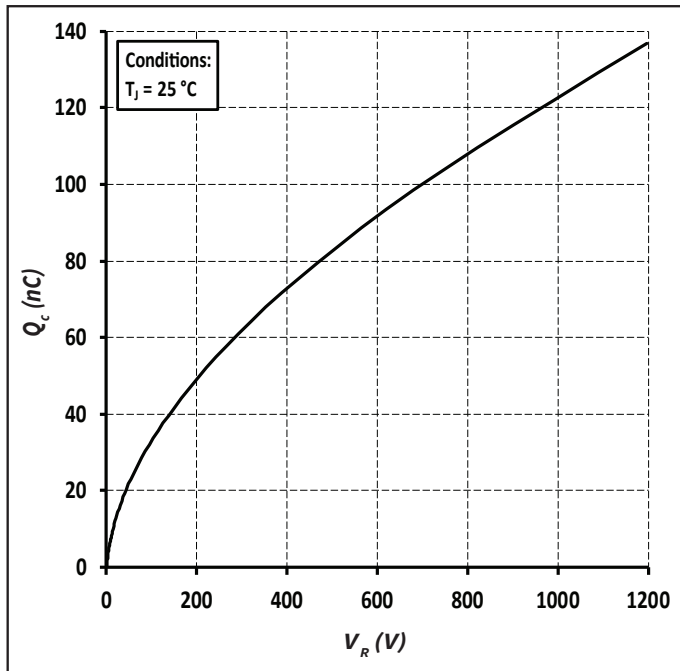

Figure 5. Recovery Charge vs. Reverse Voltage

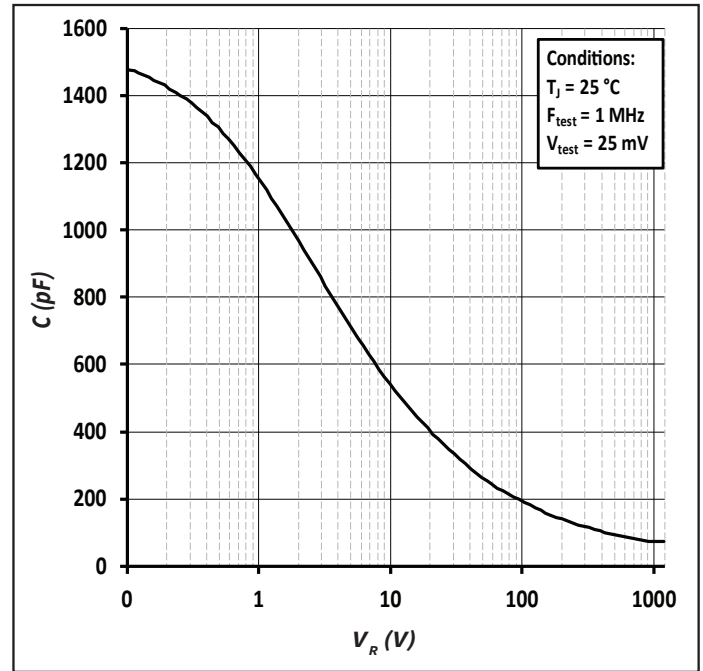

Figure 6. Capacitance vs. Reverse Voltage



Typical Performance

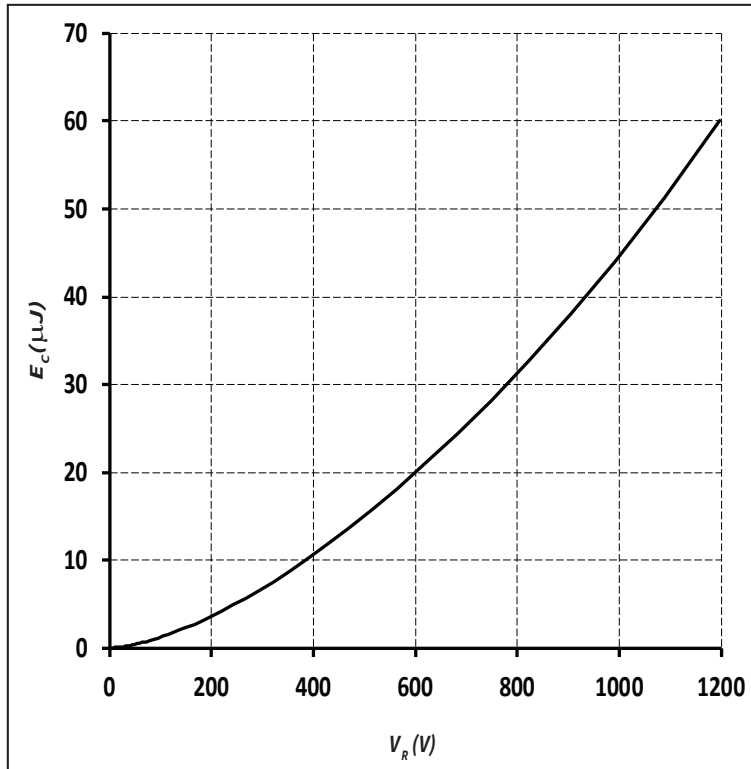

Figure 7. Typical Capacitance Stored Energy

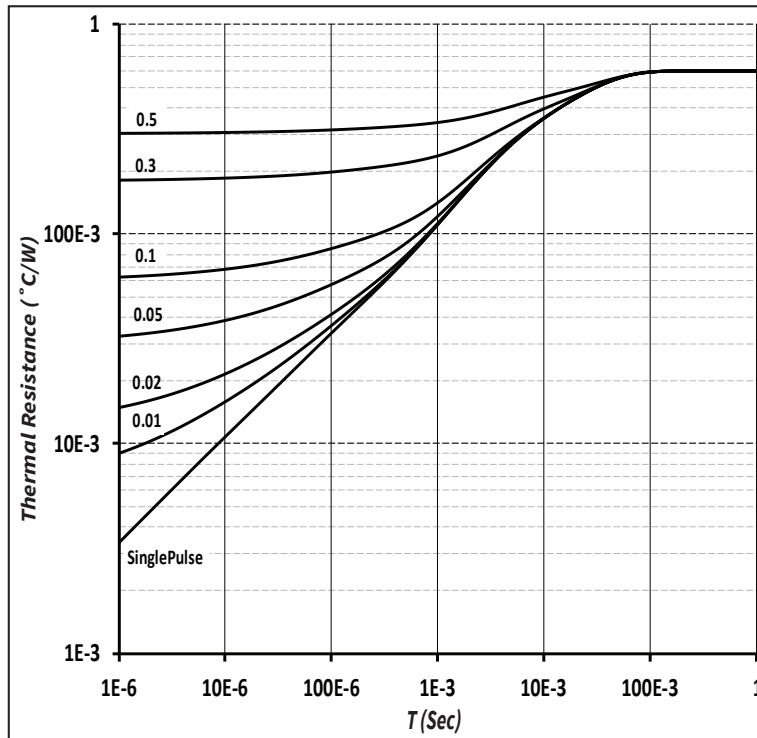
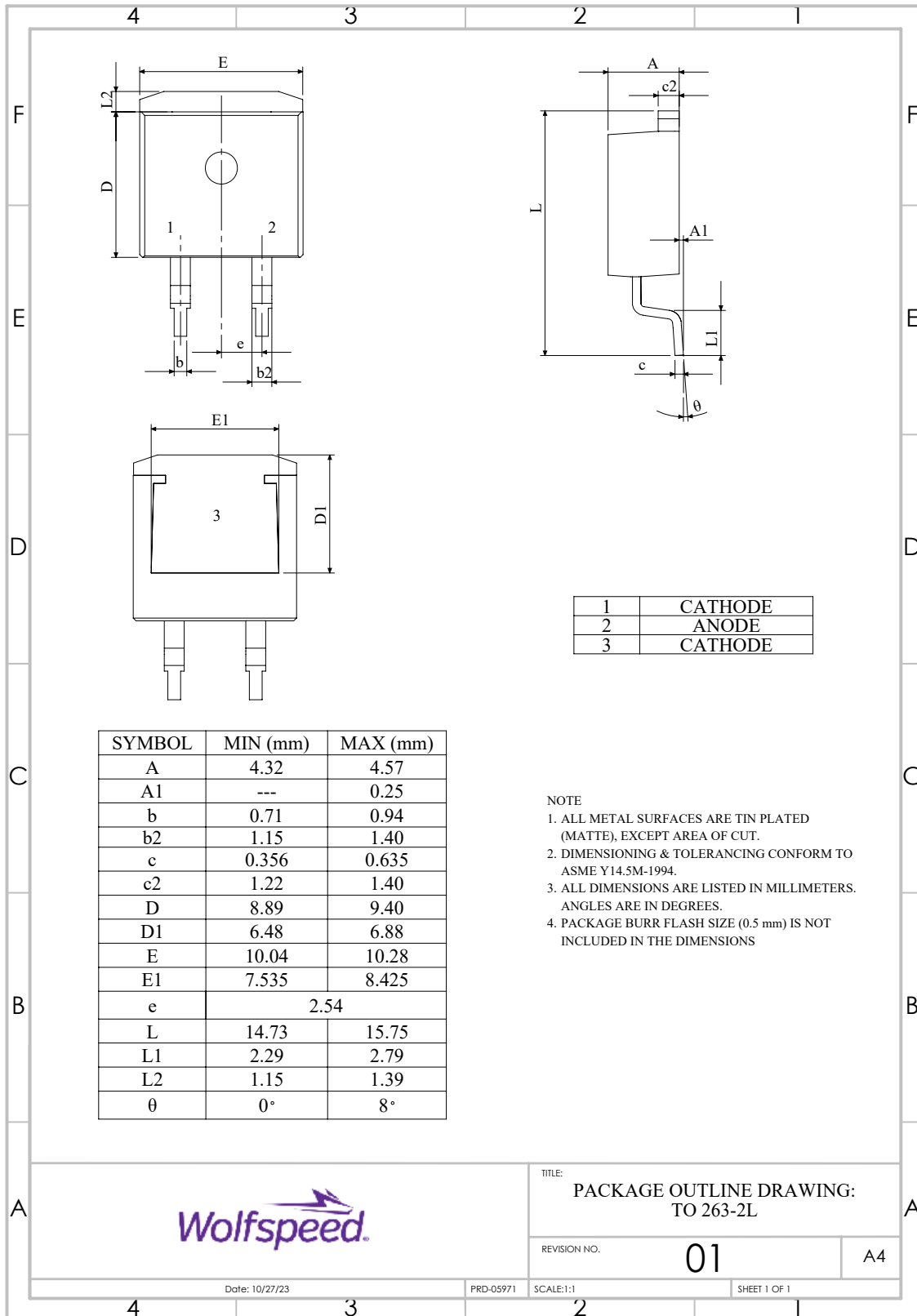

Figure 8. Transient Thermal Impedance



Package Dimensions

Package: TO-263-2





Recommended Solder Pad Layout

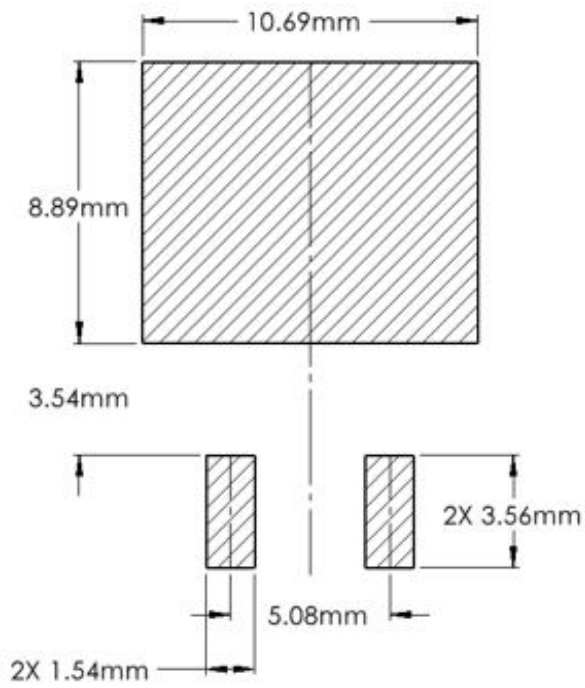

Part Number	Package	Marking
E4D20120G	TO-263-2	E4D20120



Revision History

Current Revision	Date of Release	Description of Changes
1	August-2020	Initial Release
2	October-2020	Updated Wolfspeed branding, package drawing, and solder pad layout (Not Released)
3	November-2023	Corrected Package Drawing L and L1



Notes & Disclaimer

This document and the information contained herein are subject to change without notice. Any such change shall be evidenced by the publication of an updated version of this document by Wolfspeed. No communication from any employee or agent of Wolfspeed or any third party shall effect an amendment or modification of this document. No responsibility is assumed by Wolfspeed for any infringement of patents or other rights of third parties which may result from use of the information contained herein. No license is granted by implication or otherwise under any patent or patent rights of Wolfspeed.

Notwithstanding any application-specific information, guidance, assistance, or support that Wolfspeed may provide, the buyer of this product is solely responsible for determining the suitability of this product for the buyer's purposes, including without limitation for use in the applications identified in the next bullet point, and for the compliance of the buyers' products, including those that incorporate this product, with all applicable legal, regulatory, and safety-related requirements.

This product has not been designed or tested for use in, and is not intended for use in, applications in which failure of the product would reasonably be expected to cause death, personal injury, or property damage, including but not limited to equipment implanted into the human body, life-support machines, cardiac defibrillators, and similar emergency medical equipment, aircraft navigation, communication, and control systems, aircraft power and propulsion systems, air traffic control systems, and equipment used in the planning, construction, maintenance, or operation of nuclear facilities.

RoHS Compliance

The levels of RoHS restricted materials in this product are below the maximum concentration values (also referred to as the threshold limits) permitted for such substances, or are used in an exempted application, in accordance with EU Directive 2011/65/EC (RoHS2), as implemented January 2, 2013. RoHS Declarations for this product can be obtained from your Wolfspeed representative or from the Product Documentation sections of www.wolfspeed.com.

REACH Compliance

REACH substances of high concern (SVHCs) information is available for this product. Since the European Chemical Agency (ECHA) has published notice of their intent to frequently revise the SVHC listing for the foreseeable future, please contact your Wolfspeed representative to ensure you get the most up-to-date REACH SVHC Declaration. REACH banned substance information (REACH Article 67) is also available upon request.

Contact info:

4600 Silicon Drive
Durham, NC 27703 USA
Tel: +1.919.313.5300
www.wolfspeed.com/power

Looking for pricing, stock, or lifecycle information?

Click below to explore more details on WIN SOURCE:

 [View E4D20120G on WIN SOURCE](#)

 [Cree/Wolfspeed Information](#)

Optimize Your Supply Chain with WIN SOURCE Solutions

-  Global Sourcing Solution
-  Obsolete Management
-  Cost Control Management
-  Shortage Management
-  Alternative Solution
-  Excess Inventory Management