



**THE DATASHEET OF
MIC-7900-S5A1E**



MIC-7900

Compact Fanless System with Intel® Xeon® SoC Processor



Features

- Intel® Xeon® D-1539/D-1559 SoC processor
- Wide operating temperature (-20 ~ 50 °C)
- 9 ~ 36 V_{DC} input power range
- 2 x RS-232/422/485 and 4 x RS232 serial ports (with expansion cable)
- 1 x 2.5" HDD, 1 x CFAST, 1 x M.2
- 4 x GigaLAN and 4 x USB 3.0
- Supports Advantech i-Modules, SUSIAccess, and embedded software APIs



Specifications

System Chipset	CPU	D-1539	D-1559	
	Maximum Speed	1.6GHz	1.5GHz	
	L3 Cache	12M	18M	
	Core	8	12	
	BIOS	AMI® SPI 64 Mb		
Memory	Technology	Dual-channel DDR4 2133 MHz (supports ECC)		
	Socket	2 x 260-pin SODIMM (up to 16 GB per socket)		
	Maximum Capacity	Up to 32 GB		
Display	Chipset	ASPEED 1400 with 256MB VGA memory provides basic 2D VGA function		
	VGA	1 x DP15, up to 1920 x 1200 maximum resolution		
Ethernet	Controller	LAN1: Intel® i210IT (supports wake-on-LAN) LAN2: Intel® i210IT (supports wake-on-LAN) LAN3: Intel® i210IT LAN4: Intel® i210IT		
	Interface	4 x RJ45		
Storage	HDD	1 x 2.5" HDD (with MIC-75S20 i-Module, total storage room up to 5 x 2.5" HDD)		
	CFAST	1		
	M.2	1 (Supports PCIe signals)		
I/O	USB	4 x USB 3.0 and 1 x internal USB 2.0		
	Serial Port	2 x DB9, RS232/422/485 with automatic flow control and 4 x RS-232 (with optional cable expansion)		
	Audio	2 (1 x line out and 1 x mic in)		
Security	TPM	Supports TPM 2.0 (Infineon SLB9665XQ2.0)		
Expansion	Module	Supports Advantech i-Modules (MIC-75M13/MIC-75M40/MIC-75M20/MIC-75M20-01/MIC-75M11/MIC-75S20)		
	Mini PCIe	1 x mini PCIe (does not support m-SATA)		
LED and Switch	LED	2 x TX, 2 x RX, and 1 x Storage		
	Button	1 x Power on/off switch		
Power	Type	ATX/AT		
	Input Voltage	9 ~ 36 V _{DC}		
	Power Consumption	180W (with i-Modules)		
Watchdog Timer	Output	System reset		
	Interval	Programmable 1 ~ 255 sec/min		
Environment	Temperature	Operating (with industrial SSD)	Operating (with HDD)	
		-20 ~ 50 °C with 0.7 m/s air flow	0 ~ 40 °C	
	Humidity	95% @ 40 °C (non-condensing)		
	Vibration	With SSD: 3 Grms @ 5 ~ 500 Hz, random, 1 hr/axis		
		With MIC-75S20/5xSSD: 1 Grms @ 5 ~ 500Hz, random, 1 hr/axis		
Shock	With SSD: 50G, IEC 60068-2-27, half-sine wave, 11 ms duration			
Mechanical	Dimensions (W x H x D)	74 x 192 x 230 mm (2.91" x 7.55" x 9.05")		
	Weight	2.9 kg (6.39 lbs)		
	Installation	Desktop/wall mount		
Certifications	EMC	CE/FCC Class B, CCC, BSMI		
	Safety	UL, CCC, BSMI		

Dimensions

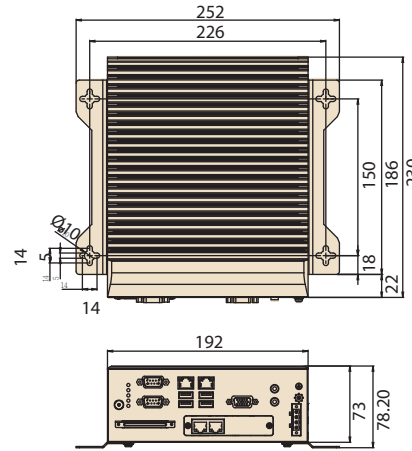
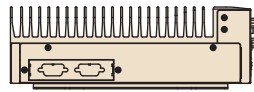
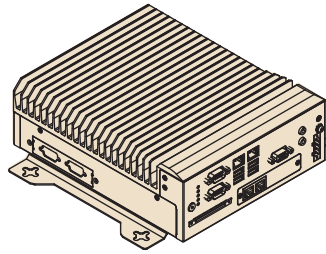

Unit: mm

Front View

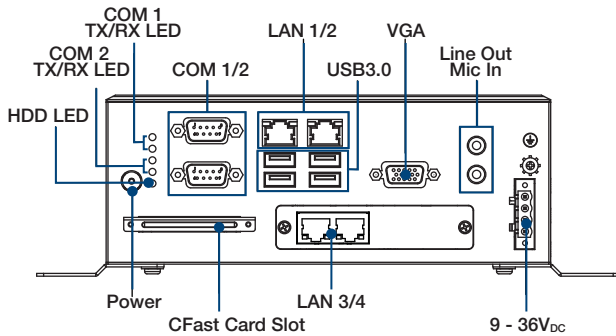

Side View

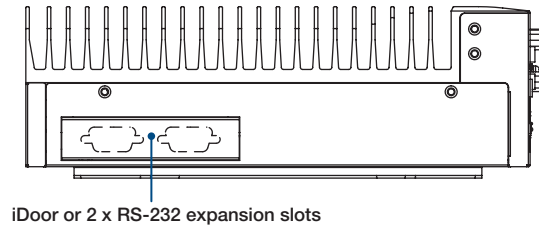

Ordering Information

Part Number	CPU	VGA	2.5" HDD	CFast	USB 3.0	GbE	COM	PCIe
MIC-7900-S5A1E	D-1559	1	1	1	4	4	2	i-Module (optional)
MIC-7900-S6A1E	D-1539	1	1	1	4	4	2	i-Module (optional)

Packing List

Part Number	Description
MIC-7900	Fanless system with Intel® Xeon® SoC processor
1652003234	4-pin Phoenix power connector
1700013095	SATA cable
1700024372-01	SATA power cable
1701200220	Dual DP9 port cable
1960070543T001	2 x Mounting bracket
2061790000	CD-ROM
2001790000	MIC-7900 startup manual (ENG+CN)
2001790010	MIC-7900 startup manual (TC)

Optional Accessories

Part Number	Description
96PSA-A220W24P4-1	Adaptor A/D, 100-240V, 220W, 24V
96PSA-A150W19P4-1	Adaptor A/D, 100-240V, 150W, 19V
1702002600	Power cord (USA) UL/CSA, 3-pin, 10A, 125V, 1.83 M, 180 D
1700022940-01	Power cord PSE, 3-pin, 7A, 125V, 3 m, DAC-ST01
1702002605	Power cord (EU) 2-pin, 10/16A, 220V, 1.83 M, 90 D
1700018704	Power Cord UK BSI 2P 10A 250V 180cm 18AWG
AIIS-DIO32-00A1E	AIIS GPIO module (32 bit)
98R2C48510E	Isolation COM module
98R1750020E	MIC-7000 series DIN rail accessory

Note:

- MIC-7900 supports Advantech iDoor modules (both MOS and PCM series). Visit the Advantech website for more information.
- The PCM series module requires a bracket (P/N: 1960065854N001) that must be ordered separately.

Optional i-Modules*

Part Number	Description
MIC-75M40	4-slot expansion module (4 x PCIe slots)
MIC-75M13	4-slot expansion module (1 x PCIe and 3 x PCI slots)
MIC-75M20	2-slot expansion module (2 x PCIe slots)
MIC-75M20-01	2-slot expansion module (2xPCIe slots)
MIC-75M11	2-slot expansion module (1 x PCIe and 1 x PCI slots)
MIC-75M10	1-slot expansion module (1xPCIe16)
MIC-75S20	2-slot expansion and storage module (2 x PCIe and 2 x 2.5 hot swappable HDDs)

*Additional i-module details provided on the following page.

Embedded OS

Part Number	Description
2070014719	WES7P MIC-7900 x64 V5.8.0 10MUI image

i-Modules for MIC-7 Series

Compatible with MIC-7 Series Fanless Systems

4-Slot Expansion Modules

MIC-75M40

- 1 x PCIe x8
- 3 x PCIe x4
- 1 x SATA (2 x 2.5" HDD bays)
- Supports 1 x 8-cm fan (optional)
- Dimensions (W x H x D): 163 x 192 x 230 mm (6.41" x 7.55" x 9.05")

Note

- For expansion cards with more than 45W power consumption, a fan should be added for thermal management.
- MIC-75M40 does not support MIC-73 series systems or MIC-7700H.



MIC-75M13

- 1 x PCIe x16
- 3 x PCI
- 1 x SATA (2 x 2.5" HDD bays)
- Supports 1 x 8-cm fan (optional)
- Dimensions (W x H x D): 163 x 192 x 230 mm (6.41" x 7.55" x 9.05")

Note

- For expansion cards with more than 45W power consumption, a fan should be added for thermal management.
- For MIC-73 series systems (with Intel® Atom™ CPU), only 1 PCIe x4 is supported.



2-Slot Expansion Modules

MIC-75M20 MIC-75M20-01

- MIC-75M20: 1 x PCIe x16/1 x PCIe x4
- MIC-75M20-01: 2 x PCIe x8
- Supports 2 x 4-cm fans (optional)
- Dimensions (W x H x D): 123 x 192 x 230 mm (4.84" x 7.55" x 9.05")

Note

- For expansion cards with more than 45W power consumption, a fan should be added for thermal management.
- MIC-75M20 does not support MIC-73 series systems.
- MIC-75M20-01 does not support MIC-7700H.



MIC-75M11

- 1 x PCIe x16
- 1 x PCI
- Supports 2 x 4-cm fans (optional)
- Dimensions (W x H x D): 123 x 192 x 230 mm (4.84" x 7.55" x 9.05")

Note

- For expansion cards with more than 45W power consumption, a fan should be added for thermal management.
- MIC-73 series systems (with Intel® Atom™ CPU) support 1 PCIe x4 or 3 PCI sockets.



MIC-75S20

- 1 x PCIe x16
- 1 x PCIe x4
- 2 x Hot-swappable HDD trays (15 mm)
- Supports 1 x 8-cm fan (optional)
- Dimensions (W x H x D): 163 x 192 x 230 mm (6.41" x 7.55" x 9.05")

Note

- Install an SSD for wide temperature range. If the system does not feature an SSD, a fan should be added for thermal management.
- MIC-75S20 does not support high-power consumption expansion cards (i.e., graphics cards).
- MIC-75S20 does not support MIC-73 series systems.



MIC-75M10

- 1 x PCIe x16
- Dimensions (W x H x D): 97 x 192 x 230 mm (3.81" x 7.55" x 9.05")

Note

- MIC-75M10 does not support fan modules.
- MIC-75M10 does not support high-power consumption expansion cards (i.e., graphics cards).



Optional Accessories

Part Number	Description
98R1751300E	8-cm fan for 4-slot i-Modules
98R1752000E	2 x 4-cm fan for 2-slot i-Modules
98R1752010E	Secondary HDD bracket (for 2-slot i-Modules)

Ordering Information

Part Number	Description
MIC-75M13-00A1E	4-slot expansion i-Module with 1 PCIe x16, 3 PCI
MIC-75M40-00A1E	4-slot expansion i-Module with 1 PCIe x8, 3 PCIe x4
MIC-75M11-00A1E	2-slot expansion i-Module with 1 PCIe x16, 1 PCI
MIC-75M20-00A1E	2-slot expansion i-Module with 1 PCIe x16, 1 PCIe x4
MIC-75M10-00A1	1-slot expansion i-Module with 1 PCIe x16
MIC-75M20-01A1E	2-slot expansion i-Module with 2 PCIe x8
MIC-75S20-00A1E	2-slot expansion i-Module with 1 PCIe x16, 1 PCIe x4, 2 2.5" HDD bay

Looking for pricing, stock, or lifecycle information?

Click below to explore more details on WIN SOURCE:

 [View MIC-7900-S5A1E on WIN SOURCE](#)

 [Advantech Corp Information](#)

Optimize Your Supply Chain with WIN SOURCE Solutions

-  Global Sourcing Solution
-  Obsolete Management
-  Cost Control Management
-  Shortage Management
-  Alternative Solution
-  Excess Inventory Management