



THE DATASHEET OF

FJ-05-D-13.98-4

win-source.net



0086-755-83957316

DO NOT SCALE FROM THIS PRINT

No OF POSITIONS
-05, -10, -15, -20, -25, -30

STYLE
**-S: SINGLE ENDED
-D: DOUBLE ENDED
-R: REVERSE STIFFENER

STRIP LENGTH
**-2: .079 [2.00]
*-4: .157 [4.00]
**-6: .236 [6.00]

LENGTH
-XX.XX: "XX" INCHES ±.125 [3.18]
(-S STYLE 2.500 [63.50] MIN)
(-D & -R STYLE 2.000 [50.80] MIN)

* = RECOMMENDED MATING WITH FC1
** = ONLY AVAILABLE TO EXISTING CUSTOMERS, ALL OTHERS WILL BE ASP's.

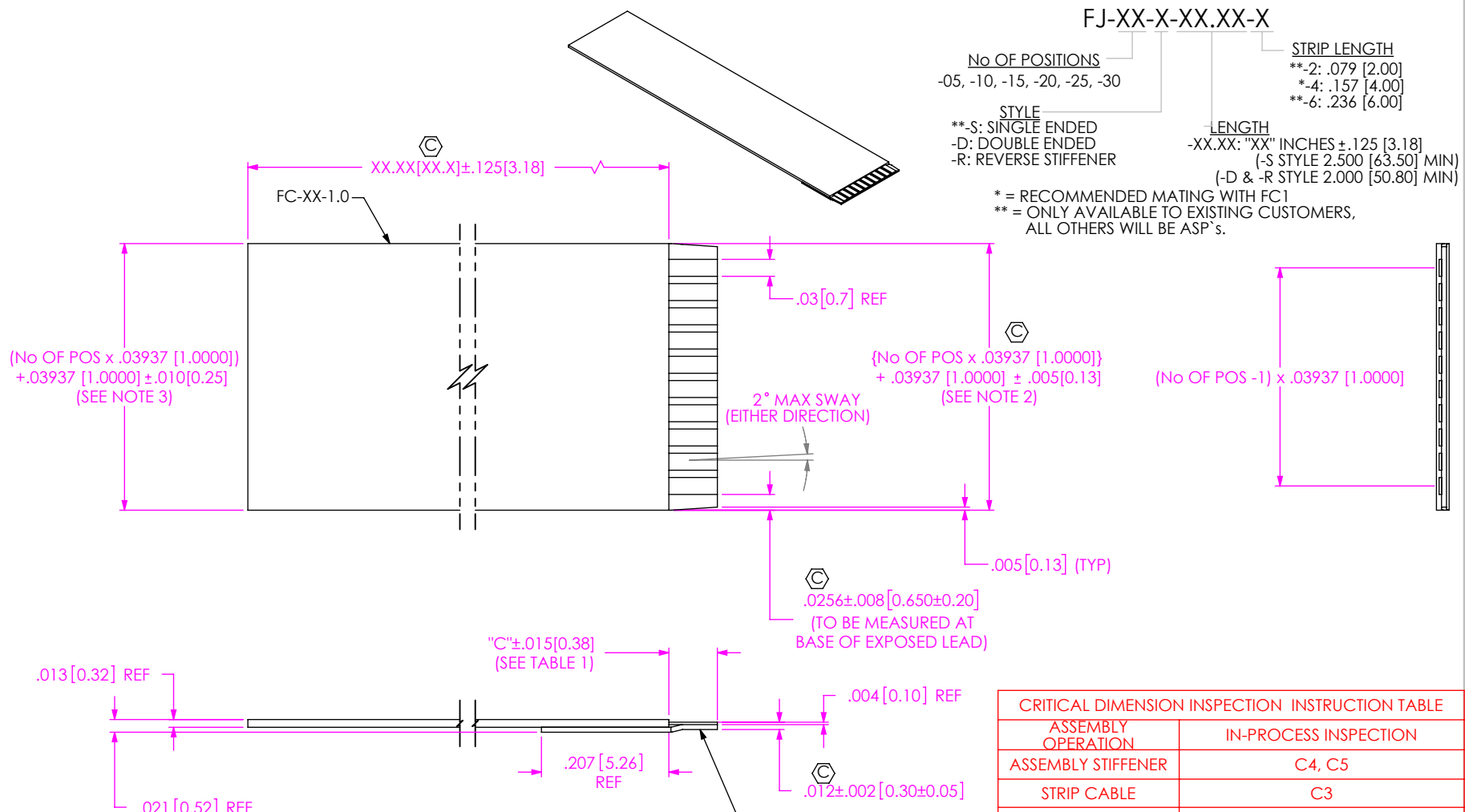

FIG 1
HAND BUILT
-S: SINGLE ENDED
(FJ-10-S-XX-2 SHOWN)

CRITICAL DIMENSION INSPECTION INSTRUCTION TABLE	
ASSEMBLY OPERATION	IN-PROCESS INSPECTION
ASSEMBLY STIFFENER	C4, C5
STRIP CABLE	C3
TRIM STIFFENER	C1, C2, C6

STRIP LENGTH	"C"
-2	.079 [2.00]
-4	.157 [4.00]
-6	.236 [6.00]

NOTES:

1. Ⓢ REPRESENTS A CRITICAL DIMENSION.
2. MEASURE WHERE STIFFENER AND CABLE ARE ATTACHED.
3. MEASURED ALONG LENGTH OF CABLE, EXCEPT WHERE STIFFENER IS ATTACHED TO CABLE.
4. NOTE DELETED.
5. STIFFENER IS TRIMMED TO CORRECT WIDTH.
6. NOTE DELETED.
7. DIMENSION TO BE MEASURED IN ALL 4 CORNERS.

UNLESS OTHERWISE SPECIFIED, DIMENSIONS ARE IN INCHES. TOLERANCES ARE:
 DECIMALS ANGLES
 .XX: ±.01 [.25] 2°
 .XXX: ±.005 [.13]
 .XXXX: ±.0020 [.050]

PROPRIETARY NOTE
 THIS DOCUMENT CONTAINS CONFIDENTIAL AND PROPRIETARY INFORMATION AND ALL DESIGN, MANUFACTURING, REPRODUCTION, USE, PATENT RIGHTS AND SALES RIGHTS ARE EXPRESSLY RESERVED BY SAMTEC, INC. THIS DOCUMENT SHALL NOT BE DISCLOSED, IN WHOLE OR PART, TO ANY UNAUTHORIZED PERSON OR ENTITY NOR REPRODUCED, TRANSFERRED OR INCORPORATED IN ANY OTHER PROJECT IN ANY MANNER WITHOUT THE EXPRESS WRITTEN CONSENT OF SAMTEC, INC.

DO NOT SCALE DRAWING SHEET SCALE: 4:1

MATERIAL:
 CONDUCTORS: TIN PLATED COPPER
 SURFACE FINISH EITHER BRIGHT ACID TIN (99.9% SN) OR MATTE TIN (95.5% SN, 3.5% AG, 1% CU)
 INSULATION: POLYESTER
 STIFFENER: POLYESTER

F:\DWG\MISC\MKTG\FJ-XX-X-XX.XX-X.MKT.SLDDRW



520 PARK EAST BLVD. NEW ALBANY, IN 47150
 PHONE: 812-944-6733 FAX: 812-948-5047
 e-Mail: info@SAMTEC.com code: 55322

DESCRIPTION:
 .03937 [1.0000] FLEX CABLE JUMPER

DWG. NO.
FJ-XX-X-XX.XX-X

BY: KEVIN B 3/29/99 SHEET 1 OF 3

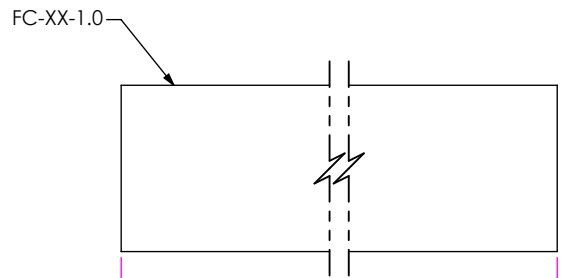

FOR -S: (XX.XX [XX.X] + .591 [15.16]) ±.050 [1.27]
 FOR -D & -R: (XX.XX [XX.X] + 1.181 [30.00]) ±.050 [1.27]

IN-PROCESS 1

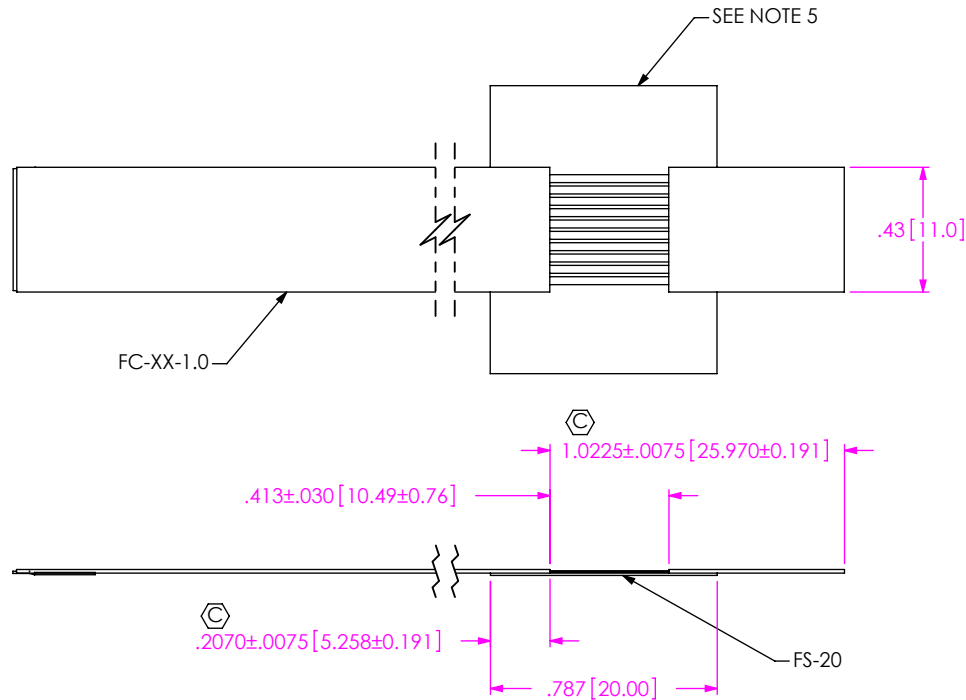

IN-PROCESS 2
 (TYP ON BOTH ENDS FOR -D & -R STYLES)

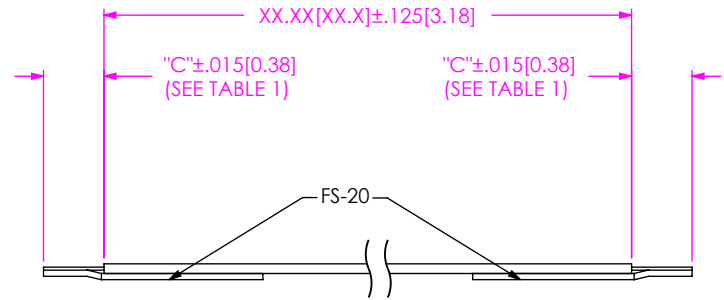

FIG 2
 -D: DOUBLE ENDED
 (SAME AS FIG 1, EXCEPT AS SHOWN)

(FIG 4 MAY BE SUBSTITUTED AT SAMTEC DISCRETION)

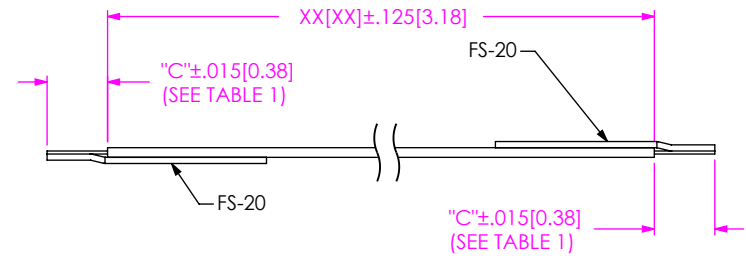

FIG 3
 -R: REVERSE STIFFENER
 (SAME AS FIG 1, EXCEPT AS SHOWN)

(FIG 5 MAY BE SUBSTITUTED AT SAMTEC DISCRETION)

PROPRIETARY NOTE
 THIS DOCUMENT CONTAINS CONFIDENTIAL AND PROPRIETARY INFORMATION AND ALL DESIGN, MANUFACTURING, REPRODUCTION, USE, PATENT RIGHTS AND SALES RIGHTS ARE EXPRESSLY RESERVED BY SAMTEC, INC. THIS DOCUMENT SHALL NOT BE DISCLOSED, IN WHOLE OR PART, TO ANY UNAUTHORIZED PERSON OR ENTITY NOR REPRODUCED, TRANSFERRED OR INCORPORATED IN ANY OTHER PROJECT IN ANY MANNER WITHOUT THE EXPRESS WRITTEN CONSENT OF SAMTEC, INC.

DO NOT SCALE DRAWING

SHEET SCALE: 3:1



520 PARK EAST BLVD, NEW ALBANY, IN 47150
 PHONE: 812-944-6733 FAX: 812-948-5047
 e-Mail: info@SAMTEC.com code: 55322

DESCRIPTION: .03937 [1.0000] FLEX CABLE JUMPER

DWG. NO. FJ-XX-X-XX.XX-X

BY: KEVIN B 3/29/99 SHEET 2 OF 3

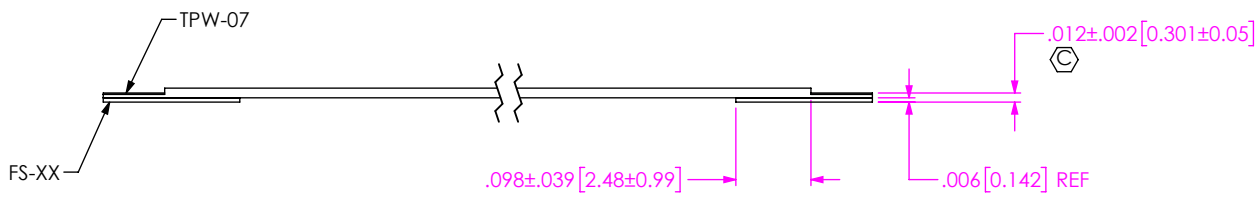
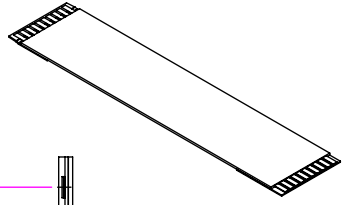
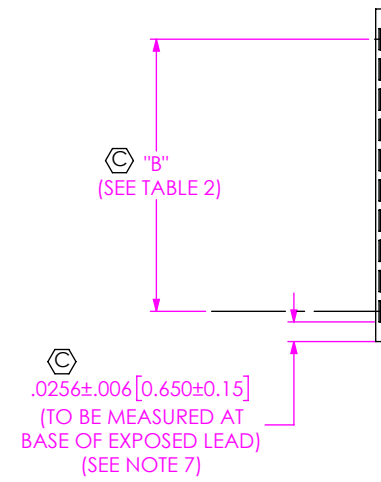
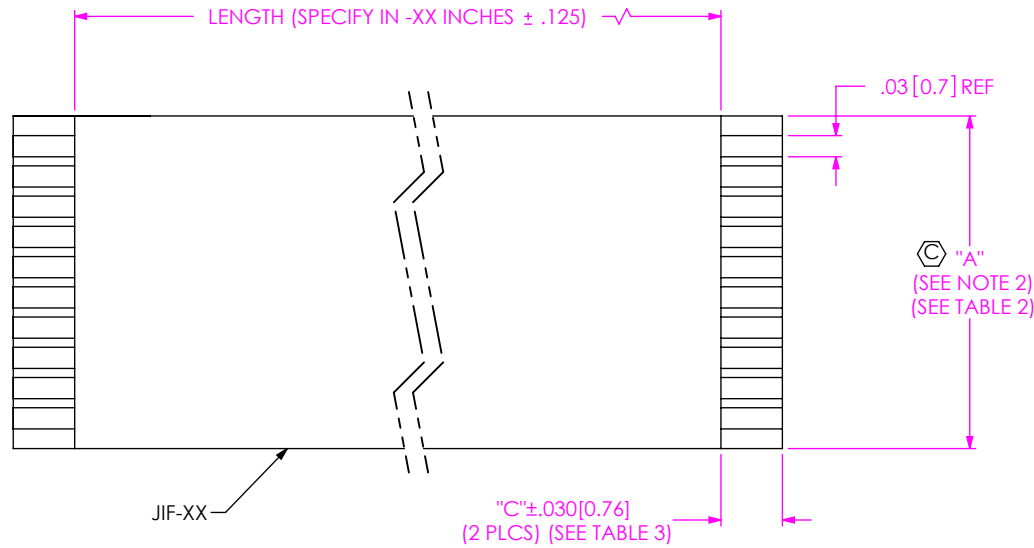

FIG 4
-D: DOUBLE ENDED
(FJ-10-D-XX.XX-4 SHOWN)

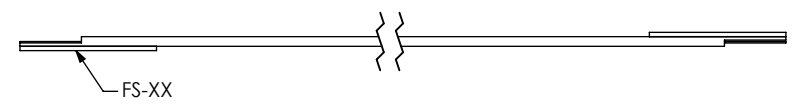

FIG 5
-R: REVERSE STIFFENER
(SAME AS FIG 4, EXCEPT AS SHOWN)

NO. OF POS	"A"	"B"
-05	.236	.157
-10	.433	.354
-15	.630	.551
-20	.827	.748
-25	1.024	.944
-30	1.221	1.142

STRIP LENGTH	"C"
-4	.157 [4.00]
-6	.236 [6.00]

No. OF POSITIONS	"No. OF CUT CABLES"
-5	6
-10	3
-15	2
-20	1
-25	1
-30	1

	TPW-07	No. OF POS + 2 x (LENGTH + .314)
-4	FS-13 (SEE STRIP LENGTH)	6.30 / No. OF CUT CABLES (SEE TABLE 4)
	JIF-120	2 x (LENGTH + .314) / No. OF CUT CABLES (SEE TABLE 4)
-6	TPW-07	No. OF POS + 2 x (LENGTH + .472)
	FS-17 (SEE STRIP LENGTH)	6.30 / No. OF CUT CABLES (SEE TABLE 4)
	JIF-120	2 x (LENGTH + .472) / No. OF CUT CABLES (SEE TABLE 4)

PROPRIETARY NOTE
 THIS DOCUMENT CONTAINS CONFIDENTIAL AND PROPRIETARY INFORMATION AND ALL DESIGN, MANUFACTURING, REPRODUCTION, USE, PATENT RIGHTS AND SALES RIGHTS ARE EXPRESSLY RESERVED BY SAMTEC, INC. THIS DOCUMENT SHALL NOT BE DISCLOSED, IN WHOLE OR PART, TO ANY UNAUTHORIZED PERSON OR ENTITY NOR REPRODUCED, TRANSFERRED OR INCORPORATED IN ANY OTHER PROJECT IN ANY MANNER WITHOUT THE EXPRESS WRITTEN CONSENT OF SAMTEC, INC.

DO NOT SCALE DRAWING

SHEET SCALE: 2:1

520 PARK EAST BLVD, NEW ALBANY, IN 47150
 PHONE: 812-944-6733 FAX: 812-948-5047
 e-Mail: info@SAMTEC.com code: 55322

DESCRIPTION: .03937 [1.0000] FLEX CABLE JUMPER

DWG. NO. FJ-XX-X-XX.XX-X

BY: KEVIN B 3/29/99 SHEET 3 OF 3

Looking for pricing, stock, or lifecycle information?

Click below to explore more details on WIN SOURCE:

 [View FJ-05-D-13.98-4 on WIN SOURCE](#)

 [Samtec Inc. Information](#)

Optimize Your Supply Chain with WIN SOURCE Solutions

-  Global Sourcing Solution
-  Obsolete Management
-  Cost Control Management
-  Shortage Management
-  Alternative Solution
-  Excess Inventory Management