



**THE DATASHEET OF
CYBL10562-56LQXI**



Programmable Radio-on-Chip With Bluetooth Low Energy (PRoC BLE)

General Description

PRoC BLE is a 32-bit, 48-MHz ARM® Cortex®-M0 BLE solution with CapSense®, 12-bit ADC, four timer, counter, pulse-width modulators (TCPWM), thirty-six GPIOs, two serial communication blocks (SCBs), LCD, and I²S. PRoC BLE includes a royalty-free BLE stack compatible with Bluetooth® 4.1 and provides a complete, programmable, and flexible solution for HID, remote controls, toys, beacons, and wireless chargers. In addition to these applications, PRoC BLE provides a simple, low-cost way to add BLE connectivity to any system.

Features

Bluetooth® Smart Connectivity

- Bluetooth 4.1 single-mode device
- 2.4-GHz BLE radio and baseband with integrated balun
- TX output power: -18 dBm to +3 dBm
- Received signal strength indicator (RSSI) with 1-dB resolution
- RX sensitivity: -89 dBm
- TX current: 15.6 mA at 0 dBm
- RX current: 16.4 mA

ARM Cortex-M0 CPU Core

- 32-bit processor (0.9 DMIPS/MHz) with single-cycle 32-bit multiply, operating at up to 48 MHz
- 128-KB flash memory
- 16-KB SRAM memory
- Emulated EEPROM using flash memory
- Watchdog timer with dedicated internal low-speed oscillator (ILO)

Ultra-Low-Power

- 1.3-µA Deep-Sleep mode with watch crystal oscillator (WCO) on
- 150-nA Hibernate mode current with SRAM retention
- 60-nA Stop mode current with GPIO wakeup

CapSense® Touch Sensing with Two-Finger Gestures

- Up to 36 capacitive sensors for buttons, sliders, and touchpads
- Two-finger gestures: scroll, inertial scroll, pinch, stretch, and edge-swipe
- Cypress Capacitive Sigma-Delta (CSD) provides best-in-class SNR (> 5:1) and liquid tolerance
- Automatic hardware-tuning algorithm (SmartSense™)

Peripherals

- 12-bit, 1-Msp/s SAR ADC with internal reference, sample-and-hold (S/H), and channel sequencer
- Ultra-low-power LCD segment drive for 128 segments with operation in Deep-Sleep mode
- Two serial communication blocks (SCBs) supporting I²C (Master/Slave), SPI (Master/Slave), or UART

- Four dedicated 16-bit TCPWMs
 - Additional four 8-bit or two 16-bit PWMs
- Programmable LVD from 1.8 V to 4.5 V
- I²S Master interface

Clock, Reset, and Supply

- Wide supply-voltage range: 1.9 V to 5.5 V
- 3-MHz to 48-MHz internal main oscillator (IMO) with 2% accuracy
- 24-MHz external clock oscillator (ECO) without load capacitance
- 32-kHz WCO

Programmable GPIOs

- 36 GPIOs configurable as open drain high/low, pull-up/pull-down, HI-Z, or strong output
- Any GPIO pin can be CapSense, LCD, or analog, with flexible pin routing

Programming and Debug

- 2-pin SWD
- In-system flash programming support

Temperature and Packaging

- Operating temperature range: -40 °C to +105 °C
- Available in 56-pin QFN (7 mm × 7 mm) and 68-ball WLCSP (3.52 mm × 3.91 mm) packages

PSoC® Creator™ Design Environment

- Easy-to-use IDE to configure, develop, program, and test a BLE application
- Option to export the design to Keil, IAR, or Eclipse

Bluetooth Low Energy Protocol Stack

- Bluetooth Low Energy protocol stack supporting generic access profile (GAP) Central, Peripheral, Observer, or Broadcaster roles
 - Switches between Central and Peripheral roles on-the-go
- Standard Bluetooth Low Energy profiles and services for interoperability
 - Custom profile and service for specific use cases

Contents

Blocks and Functionality	3	Digital Peripherals	26
CPU Subsystem	4	Memory	29
BLE Subsystem	4	System Resources	29
System Resources Subsystem	4	Ordering Information	33
Peripheral Blocks	6	Part Numbering Conventions	34
Pinouts	8	Packaging	35
Power	13	Acronyms	38
Low-Power Modes	13	Document Conventions	40
Development Support	15	Units of Measure	40
Documentation	15	Revision History	41
Online	15	Sales, Solutions, and Legal Information	42
Tools.....	15	Worldwide Sales and Design Support.....	42
Kits	15	Products	42
Electrical Specifications	16	PSoC® Solutions	42
Absolute Maximum Ratings	16	Cypress Developer Community.....	42
BLE Subsystem	16	Technical Support	42
Device-Level Specifications	19		
Analog Peripherals	24		

Not Recommended for New Designs

Blocks and Functionality

The CYBL10X6X block diagram is shown in Figure 1. There are five major subsystems: CPU subsystem, BLE subsystem, system resources, peripheral blocks, and I/O subsystem.

Figure 1. Block Diagram

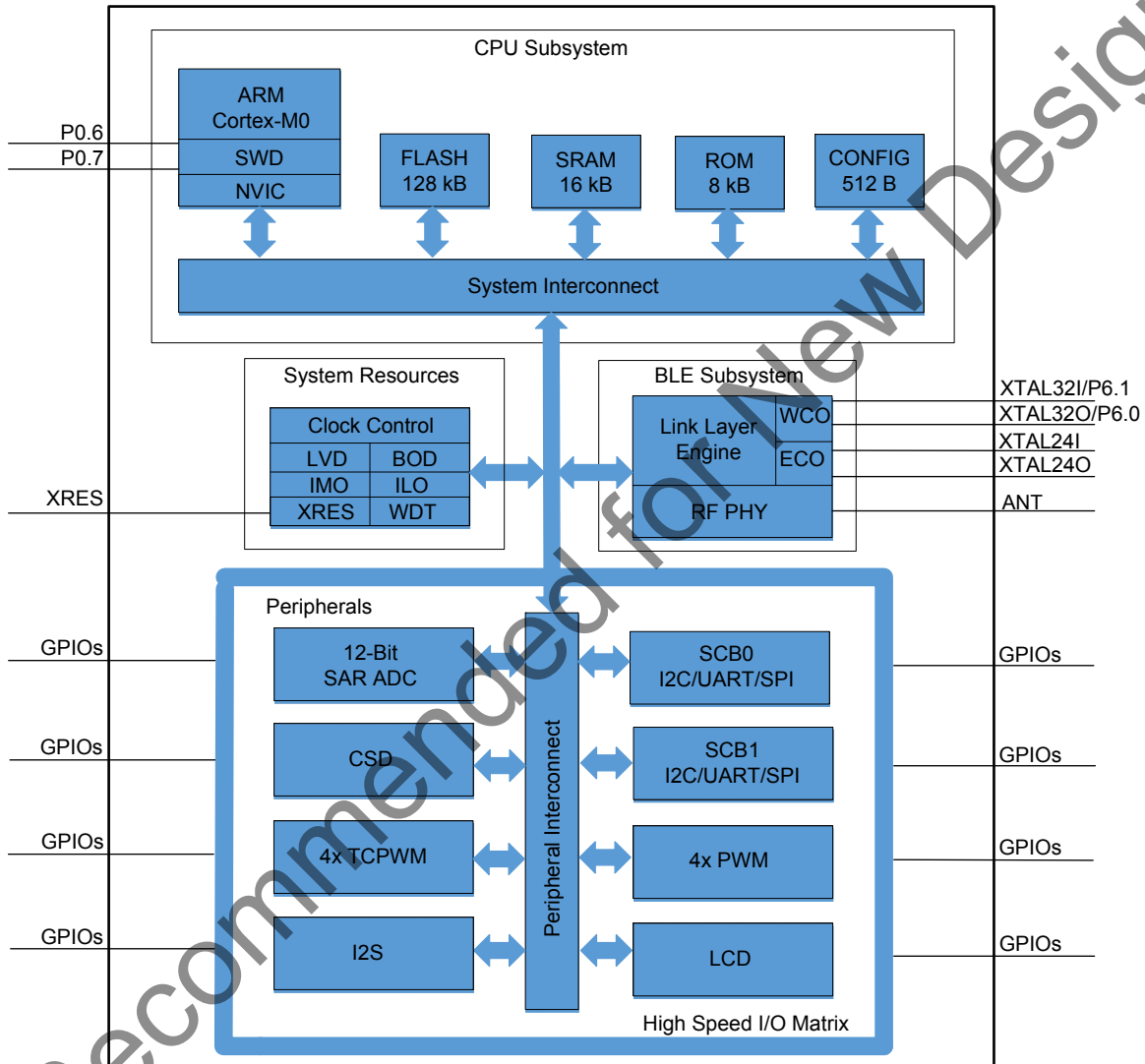

The PRoC BLE family includes extensive support for programming, testing, debugging, and tracing both hardware and firmware. The complete debug-on-chip functionality enables full-device debugging in the final system using the standard production device. It does not require special interfaces, debugging pods, simulators, or emulators. Only the standard programming connections are required to fully support debug.

The PSoC Creator IDE provides fully integrated programming and debug support for PRoC BLE devices. The SWD interface is fully compatible with industry-standard third-party tools. PRoC BLE also supports disabling the SWD interface and has a robust flash-protection feature.

CPU Subsystem

CPU

The CYBL10X6X device is based on an energy-efficient ARM Cortex-M0 32-bit processor, offering low power consumption, high performance, and reduced code size using 16-bit thumb instructions. The Cortex-M0's ability to perform single-cycle 32-bit arithmetic and logic operations, including single-cycle 32-bit multiplication, helps in better performance. The inclusion of the tightly-integrated Nested Vectored Interrupt Controller (NVIC) with 32 interrupt lines enables the Cortex-M0 to achieve a low latency and a deterministic interrupt response.

The CPU also includes a 2-pin interface, the serial wire debug (SWD), which is a 2-wire form of JTAG. The debug circuits are enabled by default and can only be disabled in firmware. If disabled, the only way to re-enable them is to erase the entire device, clear flash protection, and reprogram the device with the new firmware that enables debugging. In addition, it is possible to use the debug pins as GPIO too. The device has four breakpoints and two watchpoints for effective debugging.

Flash

The device has a 128-KB flash memory with a flash accelerator, tightly coupled to the CPU to improve average access times from flash. The flash is designed to deliver 1-wait-state (WS) access time at 48 MHz and with 0-WS access time at 24 MHz. The flash accelerator delivers 85% of single-cycle SRAM access performance on average. Part of the flash can be used to emulate EEPROM operation, if required.

During flash erase and programming operations (the maximum erase and program time is 20 ms per row), the IMO will be set to 48 MHz for the duration of the operation. This also applies to the emulated EEPROM. System design must take this into account because peripherals operating from different IMO frequencies will be affected. If it is critical that peripherals continue to operate with no change during flash programming, always set the IMO to 48 MHz and derive the peripheral clocks by dividing down from this frequency.

SRAM

The low-power 16-KB SRAM memory retains its contents even in Hibernate mode.

ROM

The 8-KB supervisory ROM contains a library of executable functions for flash programming. These functions are accessed through supervisory calls (SVC) and enable in-system programming of the flash memory.

BLE Subsystem

The BLE subsystem consists of the link layer engine and physical layer. The link layer engine supports both master and slave roles. The link layer engine implements time-critical functions such as encryption in the hardware to reduce the power consumption, and provides minimal processor intervention and a high performance. The key protocol elements, such as host control interface (HCI) and link control, are implemented in firmware. The direct test mode (DTM) is included to test the radio performance using a standard Bluetooth tester.

The physical layer consists of a modem and an RF transceiver that transmits and receives BLE packets at the rate of 1 Mbps over the 2.4-GHz ISM band. In the transmit direction, this block performs GFSK modulation and then converts the digital baseband signal of these BLE packets into radio frequency before transmitting them to air through an antenna. In the receive direction, this block converts an RF signal from the antenna to a digital bit stream after performing GFSK demodulation.

The RF transceiver contains an integrated balun, which provides a single-ended RF port pin to drive a 50-Ω antenna terminal through a pi-matching network. The output power is programmable from -18 dBm to +3 dBm to optimize the current consumption for different applications.

The Bluetooth Low Energy protocol stack uses the BLE subsystem and provides the following features:

- Link Layer (LL)
 - Master and Slave roles
 - 128-bit AES engine
 - Encryption
 - Low-duty-cycle advertising (Bluetooth 4.1 feature)
 - LE ping (Bluetooth 4.1 feature)
- Bluetooth Low Energy 4.1 single-mode protocol stack with logical link control and adaptation protocol (L2CAP), attribute (ATT), and security manager (SM) protocols
 - Master and slave roles
 - API access to generic attribute profile (GATT), generic access profile (GAP), and L2CAP
 - L2CAP connection-oriented channel (Bluetooth 4.1 feature)
 - GAP features
 - Broadcaster, Observer, Peripheral, and Central roles
 - Security mode 1: Level 1, 2, and 3
 - Security mode 2: Level 1 and 2
 - User-defined advertising data
 - Multiple-bond support
 - GATT features
 - GATT client and server
 - Supports GATT subprocedures
 - 32-bit universally unique identifiers (UUID) (Bluetooth 4.1 feature)
 - Security Manager (SM)
 - Pairing methods: Just Works, Passkey Entry, and Out of Band
 - Authenticated man-in-the-middle (MITM) protection and data signing
- Supports all SIG-adopted BLE profiles

System Resources Subsystem

Power

The power block includes internal LDOs that supply required voltage levels for different blocks. The power system also includes POR, BOD, and LVD circuits. The POR circuit holds the device in the reset state until the power supplies have stabilized at appropriate levels and the clock is ready. The BOD circuit resets the device when the supply voltage is too low for proper device operation. The LVD circuit generates an interrupt if the supply voltage drops below a user-selectable level.

An external active-LOW reset pin (XRES) can be used to reset the device. The XRES pin has an internal pull-up resistor and, in most applications, does not require any additional pull-up resistors. The power system is described in detail in the “Power” section on page 13.

Clock Control

The PRoC BLE clock control is responsible for providing clocks to all subsystems and also for switching between different clock sources without glitching. The clock control for PRoC BLE consists of the IMO and the internal low-speed oscillator (ILO). It uses the 24-MHz external crystal oscillator (ECO) and the 32-kHz WCO. In addition, an external clock may be supplied from a pin.

The device has 12 dividers with 16 divider outputs. Two dividers have additional fractional division capability. The HFCLK signal is divided down, as shown in Figure 2, to generate the system clock (SYSCLK) and peripheral clock (PERx_CLK) for different

peripherals. The system clock (SYSCLK) driving buses, registers, and the processor must be higher than all the other clocks in the system that are divided off HFCLK. The ECO and WCO are present in the BLE subsystem and the clock outputs are routed to the system resources.

Internal Main Oscillator (IMO)

The IMO is the primary system clock source, which can be adjusted in the range of 3 MHz to 48 MHz in steps of 1 MHz. The IMO accuracy is $\pm 2\%$.

Internal Low-Speed Oscillator (ILO)

The ILO is a very-low-power 32-kHz oscillator, which is primarily used to generate clocks for peripheral operations in Deep-Sleep mode. The ILO-driven counters can be calibrated to the IMO to improve accuracy. Cypress provides a software component, which does the calibration.

Figure 2. Clock Control

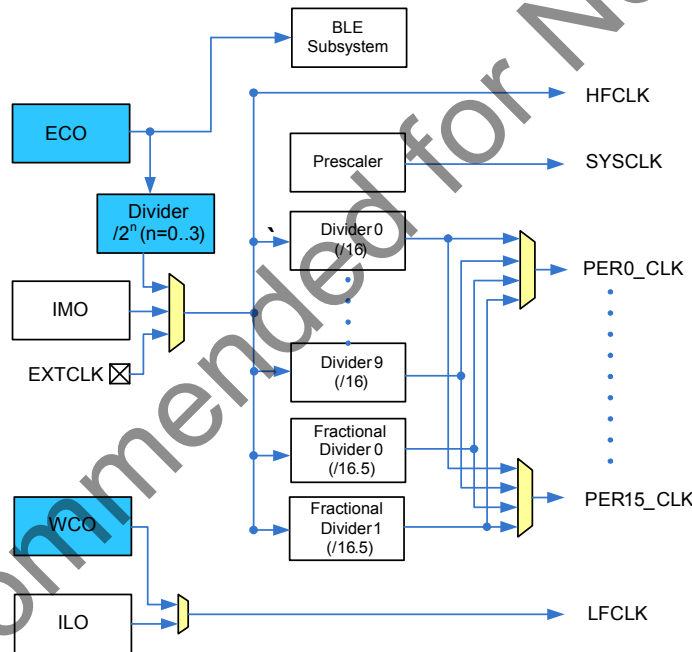

External Crystal Oscillator (ECO)

The ECO is used as the active clock for the BLE subsystem to meet the ± 50 -ppm clock accuracy requirement of the Bluetooth 4.1 specification. The ECO includes a tunable load capacitor to tune the crystal clock frequency by measuring the actual clock frequency. The high-accuracy ECO clock can also be used as a system clock.

Watch Crystal Oscillator (WCO)

The WCO is used as the sleep clock for the BLE subsystem to meet the ± 500 -ppm clock accuracy requirement of the Bluetooth 4.1 specification. The sleep clock provides accurate sleep timing and enables wakeup at specified advertisement and connection intervals. With the WCO and firmware, an accurate real-time clock (within the bounds of the 32.768-kHz crystal accuracy) can be realized.

Voltage Reference

The internal bandgap reference circuit with 1% accuracy provides the voltage reference for the 12-bit SAR ADC. To enable better SNRs and absolute accuracy, it will be possible to bypass the internal bandgap reference using a REF pin and to use an external reference for the SAR.

Watchdog Timer (WDT)

A watchdog timer is implemented in the system resources subsystem running from the ILO; this allows watchdog operations during Deep-Sleep mode and generates a watchdog reset if not serviced before the timeout occurs. The watchdog reset is recorded in the 'Reset Cause' register.

Peripheral Blocks

12-Bit SAR ADC

The ADC is a 12-bit, 1-Msps SAR ADC with a built-in sample-and-hold (S/H) circuit. The ADC can operate with either an internal voltage reference or an external voltage reference.

Preceding the SAR ADC is the SARMUX, which can route external pins and internal signals (analog mux bus and temperature sensor output) to the eight internal channels of the SAR ADC. The sequencer controller (SARSEQ) is used to control the SARMUX and SAR ADC to do an automatic scan on all enabled channels without CPU intervention and for preprocessing tasks such as averaging the output data. A Cypress-supplied software driver (Component) is used to control the ADC peripheral.

Figure 3. SAR ADC System Diagram

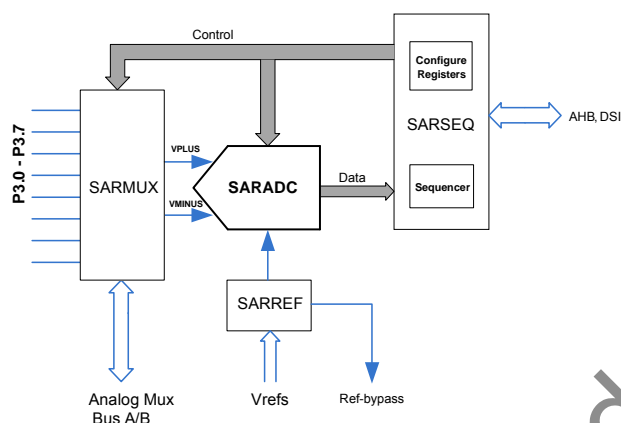

A diode based, on-chip temperature sensor is used to measure the die temperature. The temperature sensor is connected to the ADC, which digitizes the reading and produces a temperature value using the Cypress-supplied software that includes calibration and linearization.

4x Timer Counter PWM (TCPWM)

The 16-bit TCPWM module can be used to generate the PWM output or to capture the timing of edges of input signals or to provide a timer functionality. TCPWM can also be used as a 16-bit counter that supports up, down, and up/down counting modes.

Rising edge, falling edge, combined rising/falling edge detection, or pass-through on all hardware input signals can be used to derive counter events. Three routed output signals are available to indicate underflow, overflow, and counter/compare match events. A maximum of four TCPWMs are available.

4x PWM

These PWMs are in addition to the TCPWMs. The PWM peripheral can be configured as 8-bit or 16-bit resolution. The PWM provides compare outputs to generate single or continuous timing and control signals in hardware. It also provides an easy method of generating complex real-time events accurately with minimal CPU intervention. A maximum of four 8-bit PWMs or two 16-bit PWMs are available.

Serial Communication Block (SCB0/SCB1)

The SCB can be configured as an I²C, UART, or SPI interface. It supports an 8-byte FIFO for receive and transmit buffers to reduce CPU intervention. A maximum of two SCBs (SCB0, SCB1) are available.

I²C mode: The I²C peripheral is compatible with the I²C Standard-mode, Fast-mode, and Fast-Mode-Plus devices as defined in the NXP I²C-bus specification and user manual (UM10204). The I²C bus I/O is implemented with GPIOs in open-drain modes.

The hardware I²C block implements a full multimaster and slave interface (it is capable of multimaster arbitration). This block is capable of operating at speeds of up to 1 Mbps (Fast-Mode Plus) and has flexible buffering options to reduce the interrupt overhead and latency for the CPU. The I²C function is implemented using the Cypress-provided software Component (EzI2C) that creates a mailbox address range in the memory of PRoC BLE and effectively reduces the I²C communication to reading from and writing to an array in memory. In addition, the block supports an 8-byte FIFO for receive and transmit, which, by increasing the time given for the CPU to read data, greatly reduces the need for clock stretching caused by the CPU not having read the data on time.

When SCB0 is used, Serial Data (SDA) and Serial Clock (SCL) of I²C can be connected to P0.4 and P0.5, or P1.4 and P1.5, or P3.0 and P3.1.

When SCB1 is used, SDA and SCL can be connected to P0.0 and P0.1, or P3.4 and P3.5, or P5.0 and P5.1.

Configurations for I²C are as follows:

- SCB1 is fully compliant with the Standard-mode (100 kHz), Fast-mode (400 kHz), and Fast-Mode-Plus (1 MHz) I²C signaling specifications when routed to GPIO pins P5.0 and P5.1, except for hot-swap capability during I²C active communication.
- SCB1 is compliant only with Standard mode (100 kHz) when not used with P5.0 and P5.1.
- SCB0 is compliant with Standard mode (100 kHz) only.

UART mode: This is a full-feature UART operating up to 1 Mbps. It supports automotive single-wire interface (LIN), infrared interface (IrDA), and SmartCard (ISO7816) protocols. In addition, it supports the 9-bit multiprocessor mode, which allows addressing of peripherals connected over common RX and TX lines. The UART hardware flow control is supported to allow slow and fast devices to communicate with each other over UART without the risk of losing data. Refer to Table 4 on page 11 for possible UART connections to the GPIOs.

SPI Mode: The SPI mode supports full Motorola® SPI, Texas Instruments® Secure Simple Pairing (SSP) (essentially adds a start pulse used to synchronize SPI Codex), and National Microwave (half-duplex form of SPI). This block supports an 8-byte FIFO for receive and transmit. Refer to Table 4 on page 11 for the possible SPI connections to the GPIOs.

Inter-IC Sound Bus (I²S)

Inter-IC Sound Bus (I²S) is a serial bus interface standard used for connecting digital audio devices. The specification is from Philips® Semiconductor (I²S bus specification; February 1986, revised June 5, 1996).

I²S operates only in the Master mode, supporting the transmitter (TX) and the receiver (RX), which have independent data byte streams. These byte streams are packed with the most significant byte first. The number of bytes used for each sample (a sample for the left or right channel) is the minimum number of bytes to hold a sample.

LCD

The LCD controller can drive up to four commons and up to 32 segments. It uses full digital methods to drive the LCD segments providing ultra-low power consumption. The two methods used are referred to as digital correlation and PWM.

The digital correlation method modulates the frequency and signal levels of the commons and segments to generate the highest RMS voltage across a segment to light it up or to maintain the RMS signal as zero. This method is good for STN displays but may result in reduced contrast in TN (cheaper) displays.

The PWM method drives the panel with PWM signals to effectively use the capacitance of the panel to provide the integration of the modulated pulse-width to generate the desired LCD voltage. This method results in higher power consumption but provides better results in driving TN displays.

LCD operation is supported during Deep-Sleep mode by refreshing a small display buffer (four bits; one 32-bit register per port).

CapSense

CapSense is supported on all GPIOs through a Capacitive Sigma-Delta (CSD) block, which can be connected to any GPIO through an analog mux bus. Any GPIO pin can be connected to the analog mux bus via an analog switch. The CapSense function can thus be provided on any pin or group of pins in a system under software control. A software Component in PSoC Creator is provided for the CapSense block to make it easy for the user. The shield voltage can be driven on another mux bus to provide liquid-tolerance capability. Driving the shield electrode

in phase with the sense electrode keeps the shield capacitance from attenuating the sensed input.

The CapSense trackpad/touchpad with gestures has the following features:

- Supports 1-finger and 2-finger touch applications
- Supports up to 35 X/Y sensor inputs
- Includes a gesture-detection library:
 - 1-finger touch: tracing, pan, click, double-click
 - 2-finger touch: pan, click, zoom

I/O Subsystem

The I/O subsystem, which comprises the GPIO block, implements the following:

- Eight drive-strength modes:
 - Analog input mode (input and output buffers disabled)
 - Input only
 - Weak pull-up with strong pull-down
 - Weak pull-up with weak pull-down
 - Strong pull-up with weak pull-down
 - Strong pull-up with strong pull-down
 - Open drain with strong pull-down
 - Open drain with strong pull-up
- Port pins, 36
- Input threshold select (CMOS or LVTTTL)
- Individual control of input and output buffers (enabling/disabling) in addition to drive-strength modes
- Hold mode for latching the previous state (used for retaining the I/O state in Deep Sleep and Hibernate modes)
- Selectable slew rates for dV/dt to improve EMI
- The GPIO pins P5.0 and P5.1 are overvoltage-tolerant
- The GPIO cells, including P5.0 and P5.1, cannot be hot-swapped or powered up independent of the rest of the system.

Pinouts

Table 1 shows the pin list for the CYBL10X6X device.

Table 1. CYBL10X6X Pin List (QFN Package)

Pin	Name	Type	Description
1	VDDD	POWER	1.71-V to 5.5-V digital supply
2	XTAL32O/P6.0	CLOCK	32.768-kHz crystal
3	XTAL32I/P6.1	CLOCK	32.768-kHz crystal or external clock input
4	XRES	RESET	Reset, active LOW
5	P4.0	GPIO	Port 4 Pin 0, analog/digital/lcd/csd
6	P4.1	GPIO	Port 4 Pin 1, analog/digital/lcd/csd
7	P5.0	GPIO	Port 5 Pin 0, analog/digital/lcd/csd
8	P5.1	GPIO	Port 5 Pin 1, analog/digital/lcd/csd
9	VSSD	GROUND	Digital ground
10	VDDR	POWER	1.9-V to 5.5-V radio supply
11	GANT1	GROUND	Antenna shielding ground
12	ANT	ANTENNA	Antenna pin
13	GANT2	GROUND	Antenna shielding ground
14	VDDR	POWER	1.9-V to 5.5-V radio supply
15	VDDR	POWER	1.9-V to 5.5-V radio supply
16	XTAL24I	CLOCK	24-MHz crystal or external clock input
17	XTAL24O	CLOCK	24-MHz crystal
18	VDDR	POWER	1.9-V to 5.5-V radio supply
19	P0.0	GPIO	Port 0 Pin 0, analog/digital/lcd/csd
20	P0.1	GPIO	Port 0 Pin 1, analog/digital/lcd/csd
21	P0.2	GPIO	Port 0 Pin 2, analog/digital/lcd/csd
22	P0.3	GPIO	Port 0 Pin 3, analog/digital/lcd/csd
23	VDDD	POWER	1.71-V to 5.5-V digital supply
24	P0.4	GPIO	Port 0 Pin 4, analog/digital/lcd/csd
25	P0.5	GPIO	Port 0 Pin 5, analog/digital/lcd/csd
26	P0.6	GPIO	Port 0 Pin 6, analog/digital/lcd/csd
27	P0.7	GPIO	Port 0 Pin 7, analog/digital/lcd/csd
28	P1.0	GPIO	Port 1 Pin 0, analog/digital/lcd/csd
29	P1.1	GPIO	Port 1 Pin 1, analog/digital/lcd/csd
30	P1.2	GPIO	Port 1 Pin 2, analog/digital/lcd/csd
31	P1.3	GPIO	Port 1 Pin 3, analog/digital/lcd/csd
32	P1.4	GPIO	Port 1 Pin 4, analog/digital/lcd/csd
33	P1.5	GPIO	Port 1 Pin 5, analog/digital/lcd/csd
34	P1.6	GPIO	Port 1 Pin 6, analog/digital/lcd/csd
35	P1.7	GPIO	Port 1 Pin 7, analog/digital/lcd/csd
36	VDDA	POWER	1.71-V to 5.5-V analog supply
37	P2.0	GPIO	Port 2 Pin 0, analog/digital/lcd/csd
38	P2.1	GPIO	Port 2 Pin 1, analog/digital/lcd/csd
39	P2.2	GPIO	Port 2 Pin 2, analog/digital/lcd/csd
40	P2.3	GPIO	Port 2 Pin 3, analog/digital/lcd/csd

Table 1. CYBL10X6X Pin List (QFN Package) (continued)

Pin	Name	Type	Description
41	P2.4	GPIO	Port 2 Pin 4, analog/digital/lcd/csd
42	P2.5	GPIO	Port 2 Pin 5, analog/digital/lcd/csd
43	P2.6	GPIO	Port 2 Pin 6, analog/digital/lcd/csd
44	P2.7	GPIO	Port 2 Pin 7, analog/digital/lcd/csd
45	VREF	REF	1.024-V reference
46	VDDA	POWER	1.71-V to 5.5-V analog supply
47	P3.0	GPIO	Port 3 Pin 0, analog/digital/lcd/csd
48	P3.1	GPIO	Port 3 Pin 1, analog/digital/lcd/csd
49	P3.2	GPIO	Port 3 Pin 2, analog/digital/lcd/csd
50	P3.3	GPIO	Port 3 Pin 3, analog/digital/lcd/csd
51	P3.4	GPIO	Port 3 Pin 4, analog/digital/lcd/csd
52	P3.5	GPIO	Port 3 Pin 5, analog/digital/lcd/csd
53	P3.6	GPIO	Port 3 Pin 6, analog/digital/lcd/csd
54	P3.7	GPIO	Port 3 Pin 7, analog/digital/lcd/csd
55	VSSA	GROUND	Analog ground
56	VCCD	POWER	Regulated 1.8-V supply, connect to 1- μ F capacitor
57	EPAD	GROUND	Ground paddle for the QFN package

Table 2 shows the pin list for the CYBL10X6X device (WLCSP package).

Table 2. CYBL10X6X Pin List (WLCSP Package)

Pin	Name	Type	Description
A1	VREF	REF	1.024-V reference
A2	VSSA	GROUND	Analog ground
A3	P3.3	GPIO	Port 3 Pin 3, analog/digital/lcd/csd
A4	P3.7	GPIO	Port 3 Pin 7, analog/digital/lcd/csd
A5	VSSD	GROUND	Digital ground
A6	VSSA	GROUND	Analog ground
A7	VCCD	POWER	Regulated 1.8-V supply, connect to 1- μ F capacitor
A8	VDDD	POWER	1.71-V to 5.5-V digital supply
B1	P2.3	GPIO	Port 2 Pin 3, analog/digital/lcd/csd
B2	VSSA	GROUND	Analog ground
B3	P2.7	GPIO	Port 2 Pin 7, analog/digital/lcd/csd
B4	P3.4	GPIO	Port 3 Pin 4, analog/digital/lcd/csd
B5	P3.5	GPIO	Port 3 Pin 5, analog/digital/lcd/csd
B6	P3.6	GPIO	Port 3 Pin 6, analog/digital/lcd/csd
B7	XTAL32I/P6.1	CLOCK	32.768-kHz crystal or external clock input
B8	XTAL32O/P6.0	CLOCK	32.768-kHz crystal
C1	VSSA	GROUND	Analog ground
C2	P2.2	GPIO	Port 2 Pin 2, analog/digital/lcd/csd
C3	P2.6	GPIO	Port 2 Pin 6, analog/digital/lcd/csd
C4	P3.0	GPIO	Port 3 Pin 0, analog/digital/lcd/csd

Table 2. CYBL10X6X Pin List (WLCSP Package) (continued)

Pin	Name	Type	Description
C5	P3.1	GPIO	Port 3 Pin 1, analog/digital/lcd/csd
C6	P3.2	GPIO	Port 3 Pin 2, analog/digital/lcd/csd
C7	XRES	RESET	Reset, active LOW
C8	P4.0	GPIO	Port 4 Pin 0, analog/digital/lcd/csd
D1	P1.7	GPIO	Port 1 Pin 7, analog/digital/lcd/csd
D2	VDDA	POWER	1.71-V to 5.5-V analog supply
D3	P2.0	GPIO	Port 2 Pin 0, analog/digital/lcd/csd
D4	P2.1	GPIO	Port 2 Pin 1, analog/digital/lcd/csd
D5	P2.5	GPIO	Port 2 Pin 5, analog/digital/lcd/csd
D6	VSSD	GROUND	Digital ground
D7	P4.1	GPIO	Port 4 Pin 1, analog/digital/lcd/csd
D8	P5.0	GPIO	Port 5 Pin 0, analog/digital/lcd/csd, overvoltage-tolerant
E1	P1.2	GPIO	Port 1 Pin 2, analog/digital/lcd/csd
E2	P1.3	GPIO	Port 1 Pin 3, analog/digital/lcd/csd
E3	P1.4	GPIO	Port 1 Pin 4, analog/digital/lcd/csd
E4	P1.5	GPIO	Port 1 Pin 5, analog/digital/lcd/csd
E5	P1.6	GPIO	Port 1 Pin 6, analog/digital/lcd/csd
E6	P2.4	GPIO	Port 2 Pin 4, analog/digital/lcd/csd
E7	P5.1	GPIO	Port 5 Pin 1, analog/digital/lcd/csd, overvoltage-tolerant
E8	VSSD	GROUND	Digital ground
F1	VSSD	GROUND	Digital ground
F2	P0.7	GPIO	Port 0 Pin 7, analog/digital/lcd/csd
F3	P0.3	GPIO	Port 0 Pin 3, analog/digital/lcd/csd
F4	P1.0	GPIO	Port 1 Pin 0, analog/digital/lcd/csd
F5	P1.1	GPIO	Port 1 Pin 1, analog/digital/lcd/csd
F6	VSSR	GROUND	Radio ground
F7	VSSR	GROUND	Radio ground
F8	VDDR	POWER	1.9-V to 5.5-V radio supply
G1	P0.6	GPIO	Port 0 Pin 6, analog/digital/lcd/csd
G2	VDDD	POWER	1.71-V to 5.5-V digital supply
G3	P0.2	GPIO	Port 0 Pin 2, analog/digital/lcd/csd
G4	VSSD	GROUND	Digital ground
G5	VSSR	GROUND	Radio ground
G6	VSSR	GROUND	Radio ground
G7	GANT	GROUND	Antenna shielding ground
G8	VSSR	GROUND	Radio ground
H1	P0.5	GPIO	Port 0 Pin 5, analog/digital/lcd/csd
H2	P0.1	GPIO	Port 0 Pin 1, analog/digital/lcd/csd
H3	XTAL24O	CLOCK	24-MHz crystal
H4	XTAL24I	CLOCK	24-MHz crystal or external clock input

Table 2. CYBL10X6X Pin List (WLCSP Package) (continued)

Pin	Name	Type	Description
H5	VSSR	GROUND	Radio ground
H6	VSSR	GROUND	Radio ground
H7	ANT	ANTENNA	Antenna pin
J1	P0.4	GPIO	Port 0 Pin 4, analog/digital/lcd/csd
J2	P0.0	GPIO	Port 0 Pin 0, analog/digital/lcd/csd
J3	VDDR	POWER	1.9-V to 5.5-V radio supply
J6	VDDR	POWER	1.9-V to 5.5-V radio supply
J7	NO CONNECT	-	

The I/O subsystem consists of a high-speed I/O matrix (HSIOM), which is a group of high-speed switches that routes GPIOs to the resources inside the device. These resources include CapSense, TCPWMs, I²C, SPI, UART, and LCD. HSIOM_PORT_SELx are 32-bit-wide registers that control the routing of GPIOs. Each register controls one port; four dedicated bits are assigned to each GPIO in the port. This provides up to 16 different options for GPIO routing as shown in [Table 3](#).

Table 3. HSIOM Port Settings

Value	Description
0	Firmware-controlled GPIO
1	Reserved
2	Reserved
3	Reserved
4	Pin is a CSD sense pin
5	Pin is a CSD shield pin
6	Pin is connected to AMUXA
7	Pin is connected to AMUXB
8	Pin-specific Active function #0
9	Pin-specific Active function #1
10	Pin-specific Active function #2
11	Reserved
12	Pin is an LCD common pin
13	Pin is an LCD segment pin
14	Pin-specific Deep-Sleep function #0
15	Pin-specific Deep-Sleep function #1

The selection of peripheral functions for different GPIO pins is given in [Table 4](#).

Table 4. Port Pin Connections^[1]

Name	Analog	Digital (HSIOM_PORT_SELx.SELy) ('x' denotes port number and 'y' denotes pin number)					
		0	8	9	10	14	15
		GPIO	Active #0	Active #1	Active #2	Deep Sleep #0	Deep Sleep #1
P0.0		GPIO	TCPWM0_P[3]	SCB1_UART_RX[1]		SCB1_I2C_SDA[1]	SCB1_SPI_MOSI[1]
P0.1		GPIO	TCPWM0_N[3]	SCB1_UART_TX[1]		SCB1_I2C_SCL[1]	SCB1_SPI_MISO[1]
P0.2		GPIO	TCPWM1_P[3]	SCB1_UART_RTS[1]			'SCB1_SPI_SS0[1]'
P0.3		GPIO	TCPWM1_N[3]	SCB1_UART_CTS[1]			SCB1_SPI_SCLK[1]

Note

1. For devices with only 1 SCB, use pins corresponding to SCB1.

Table 4. Port Pin Connections^[1] (continued)

Name	Analog	Digital (HSIOM_PORT_SELx.SELy) ('x' denotes port number and 'y' denotes pin number)					
		0	8	9	10	14	15
		GPIO	Active #0	Active #1	Active #2	Deep Sleep #0	Deep Sleep #1
P0.4		GPIO	TCPWM1_P[0]	SCB0_UART_RX[1]	EXT_CLK[0]/ ECO_OUT[0]	SCB0_I2C_SDA[1]	SCB0_SPI_MOSI[1]
P0.5		GPIO	TCPWM1_N[0]	SCB0_UART_TX[1]		SCB0_I2C_SCL[1]	SCB0_SPI_MISO[1]
P0.6		GPIO	TCPWM2_P[0]	SCB0_UART_RTS[1]		SWDIO[0]	SCB0_SPI_SS0[1]
P0.7		GPIO	TCPWM2_N[0]	SCB0_UART_CTS[1]		SWDCLK[0]	SCB0_SPI_SCLK[1]
P1.0		GPIO	TCPWM0_P[1]				WCO_OUT[2]
P1.1		GPIO	TCPWM0_N[1]				SCB1_SPI_SS1
P1.2		GPIO	TCPWM1_P[1]				SCB1_SPI_SS2
P1.3		GPIO	TCPWM1_N[1]				SCB1_SPI_SS3
P1.4		GPIO	TCPWM2_P[1]	SCB0_UART_RX[0]		SCB0_I2C_SDA[0]	SCB0_SPI_MOSI[1]
P1.5		GPIO	TCPWM2_N[1]	SCB0_UART_TX[0]		SCB0_I2C_SCL[0]	SCB0_SPI_MISO[1]
P1.6		GPIO	TCPWM3_P[1]	SCB0_UART_RTS[0]			SCB0_SPI_SS0[1]
P1.7		GPIO	TCPWM3_N[1]	SCB0_UART_CTS[0]			SCB0_SPI_SCLK[1]
P2.0		GPIO					SCB0_SPI_SS1
P2.1		GPIO					SCB0_SPI_SS2
P2.2		GPIO				WAKEUP	SCB0_SPI_SS3
P2.3		GPIO					WCO_OUT[1]
P2.4		GPIO					
P2.5		GPIO					
P2.6		GPIO					
P2.7		GPIO			EXT_CLK[1]/ ECO_OUT[1]		
P3.0	SARMUX_0	GPIO	TCPWM0_P[2]	SCB0_UART_RX[2]		SCB0_I2C_SDA[2]	
P3.1	SARMUX_1	GPIO	TCPWM0_N[2]	SCB0_UART_TX[2]		SCB0_I2C_SCL[2]	
P3.2	SARMUX_2	GPIO	TCPWM1_P[2]	SCB0_UART_RTS[2]			
P3.3	SARMUX_3	GPIO	TCPWM1_N[2]	SCB0_UART_CTS[2]			
P3.4	SARMUX_4	GPIO	TCPWM2_P[2]	SCB1_UART_RX[2]		SCB1_I2C_SDA[2]	
P3.5	SARMUX_5	GPIO	TCPWM2_N[2]	SCB1_UART_TX[2]		SCB1_I2C_SCL[2]	
P3.6	SARMUX_6	GPIO	TCPWM3_P[2]	SCB1_UART_RTS[2]			
P3.7	SARMUX_7	GPIO	TCPWM3_N[2]	SCB1_UART_CTS[2]			WCO_OUT[0]
P4.0	CMOD	GPIO	TCPWM0_P[0]	SCB1_UART_RTS[0]			SCB1_SPI_MOSI[0]
P4.1	CTANK	GPIO	TCPWM0_N[0]	SCB1_UART_CTS[0]			SCB1_SPI_MISO[0]
P5.0		GPIO	TCPWM3_P[0]	SCB1_UART_RX[0]	EXTPA_EN	SCB1_I2C_SDA[0]	SCB1_SPI_SS0[0]
P5.1		GPIO	TCPWM3_N[0]	SCB1_UART_TX[0]	EXT_CLK[2]/ ECO_OUT[2]	SCB1_I2C_SCL[0]	SCB1_SPI_SCLK[0]
P6.0_XTAL32O		GPIO					
P6.1_XTAL32I		GPIO					

Power

PRoC BLE can be supplied from batteries with a voltage range of 1.9 V to 5.5 V by directly connecting to the digital supply (V_{DDD}), analog supply (V_{DDA}), and radio supply (V_{DDR}) pins. The internal LDOs in the device regulate the supply voltage to required levels for different blocks. The device has one regulator for the digital circuitry and separate regulators for radio circuitry for noise isolation. The analog circuits run directly from the analog supply (V_{DDA}) input. The device uses separate regulators for Deep Sleep and Hibernate modes to minimize the power consumption. The radio stops working below 1.9 V, but the rest of the system continues to function down to 1.71 V without RF. Note that V_{DDR} must be supplied whenever V_{DDD} is supplied.

Bypass capacitors must be used from $VDDx$ ($x = A, D, \text{ or } R$) to ground. The typical practice for systems in this frequency range is to use a capacitor in the 1- μF range in parallel with a smaller capacitor (for example, 0.1 μF). Note that these are simply rules of thumb and that, for critical applications, the PCB layout, lead inductance, and the bypass capacitor parasitic should be simulated to design to obtain optimal bypassing.

Power Supply	Bypass Capacitors
V_{DDD}	0.1- μF ceramic at each pin plus bulk capacitor 1 μF to 10 μF
V_{DDA}	0.1- μF ceramic at each pin plus bulk capacitor 1 μF to 10 μF
V_{DDR}	0.1- μF ceramic at each pin plus bulk capacitor 1 μF to 10 μF
V_{CCD}	1- μF ceramic capacitor at the V_{CCD} pin
V_{REF} (optional)	The internal bandgap may be bypassed with a 1- μF to 10- μF capacitor

Low-Power Modes

PRoC BLE supports five power modes. Refer to [Table 5](#) for more details on the system status. The PRoC BLE device consumes the lowest current in Stop mode; the device wakeup from stop mode is with a system reset through the XRES or WAKEUP pin. It can retain the SRAM data in Hibernate mode and is capable of retaining the complete system status in Deep-Sleep mode. [Table 5](#) shows the different power modes and the peripherals that are active.

Table 5. Power Modes System Status

Power Mode	Current Consumption	Code Execution	Digital Peripherals Available	Analog Peripherals Available	Clock Sources Available	Wake Up Sources	Wake-Up Time
Active	850 μA + 260 μA per MHz ²	Yes	All	All	All	–	–
Sleep	1.1 mA at 3 MHz	No	All	All	All	Any interrupt source	0
Deep Sleep	1.3 μA	No	WDT, LCD, I ² C/SPI, Link-Layer	POR, BOD	WCO, ILO	GPIO, WDT, I ² C/SPI Link Layer	25 μs
Hibernate	150 nA	No	No	POR, BOD	No	GPIO	2 ms
Stop	60 nA	No	No	No	No	Wake-Up pin, XRES	2 ms

Note

2. For CPU subsystem.

A typical system application connection diagram for the 56-QFN package is shown in [Figure 4](#).

Figure 4. PRoC BLE Applications Diagram

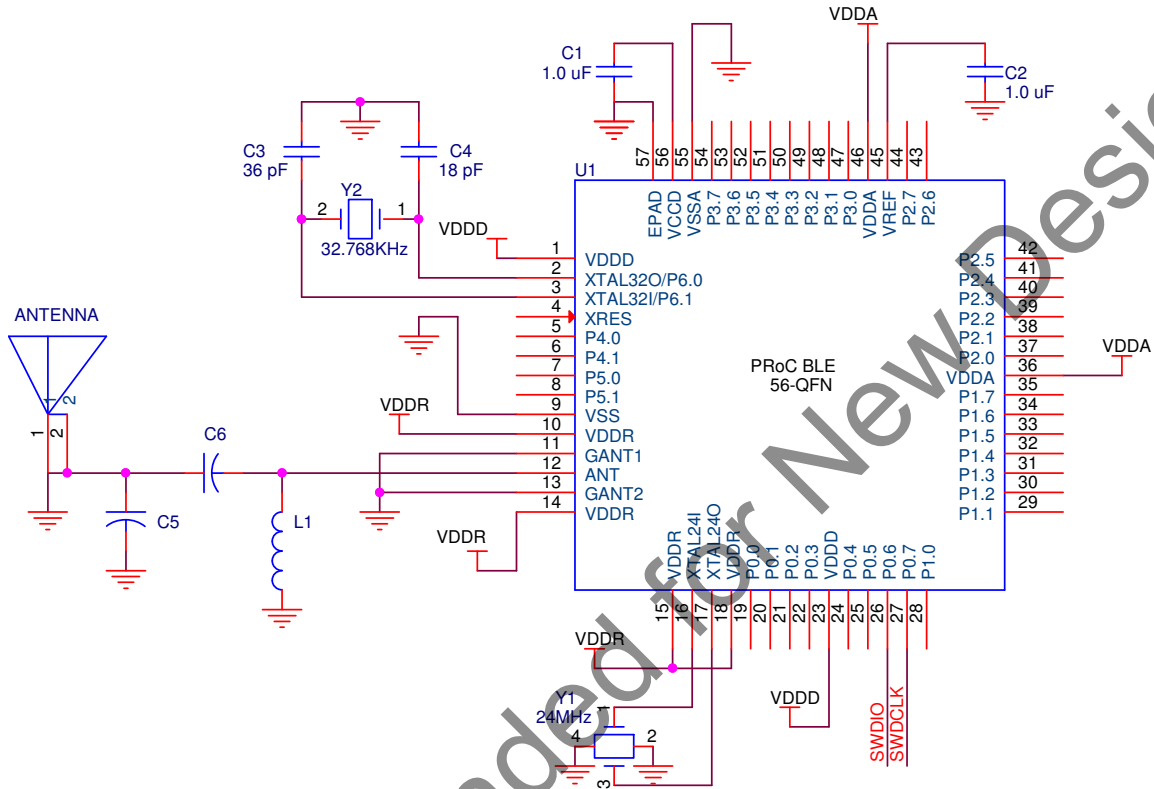

Not Recommended for New Designs

Development Support

The CYBL10X6X family has a rich set of documentation, development tools, and online resources to assist you during your development process. Visit www.cypress.com/procble to find out more.

Documentation

A suite of documentation supports the CYBL10X6X family to ensure that you find answers to your questions quickly. This section contains a list of some of the key documents.

Component Datasheets: PSoC Creator Components provide hardware abstraction using APIs to configure and control peripheral activity. The Component datasheet covers Component features, its usage and operation details, API description, and electrical specifications. This is the primary documentation used during development. These Components can represent peripherals on the device (such as a timer, I²C, or UART) or high-level system functions (such as the BLE Component).

Application Notes: Application notes help you to understand how to use various device features. They also provide guidance on how to solve a variety of system design challenges.

Technical Reference Manual (TRM): The TRM describes all peripheral functionality in detail, with register-level descriptions. This document is divided into two parts: the Architecture TRM and the Register TRM.

Online

In addition to the print documentation, Cypress forums connect you with fellow users and experts from around the world, 24 hours a day, 7 days a week.

Tools

With industry-standard cores, programming, and debugging interfaces, the CYBL10X6X family is part of a development tool ecosystem.

Visit us at www.cypress.com/go/psoccreator for the latest information on the revolutionary, easy-to-use PSoC Creator IDE, supported third-party compilers, programmers, and debuggers.

Kits

Cypress provides a portfolio of kits to accelerate time-to-market. Visit us at www.cypress.com/procble.

Not Recommended for New Designs

Electrical Specifications

This section provides detailed electrical characteristics. Absolute maximum rating for the CYBL10X6X devices is listed in the following table. Usage above the absolute maximum conditions may cause permanent damage to the device.

Exposure to absolute maximum conditions for extended periods of time may affect device reliability.

The maximum storage temperature is 150 °C in compliance with JEDEC Standard JESD22-A103, High Temperature Storage Life. When used below absolute maximum conditions, but above normal operating conditions, the device may not operate to the specification.

Absolute Maximum Ratings

Table 6. Absolute Maximum Ratings

Spec ID#	Parameter	Description	Min	Typ	Max	Units	Details/ Conditions
SID1	V _{DDD_ABS}	Analog, digital, or radio supply relative to V _{SS} (V _{SSD} = V _{SSA})	-0.5	-	6	V	Absolute max
SID2	V _{CCD_ABS}	Direct digital core voltage input relative to V _{SSD}	-0.5	-	1.95	V	Absolute max
SID3	V _{GPI0_ABS}	GPIO voltage	-0.5	-	V _{DD} + 0.5	V	Absolute max
SID4	I _{GPI0_ABS}	Maximum current per GPIO	-25	-	25	mA	Absolute max
SID5	I _{GPI0_injection}	GPIO injection current, Max for V _{IH} > V _{DDD} , and Min for V _{IL} < V _{SS}	-0.5	-	0.5	mA	Absolute max, current injected per pin
BID57	ESD_HBM	Electrostatic discharge human body model	2200 ^[3]	-	-	V	
BID58	ESD_CDM	Electrostatic discharge charged device model	500	-	-	V	
BID61	LU	Pin current for latch up	-200	-	200	mA	

BLE Subsystem

Table 7. BLE Subsystem

Spec ID#	Parameter	Description	Min	Typ	Max	Units	Details/ Conditions
RF Receiver Specifications							
SID340	RXS, IDLE	RX sensitivity with idle transmitter	-	-89	-	dBm	
SID340A	RXS, IDLE	RX sensitivity with idle transmitter excluding balun loss	-	-91	-	dBm	Guaranteed by design simulation
SID341	RXS, DIRTY	RX sensitivity with dirty transmitter	-	-87	-	dBm	RF-PHY Specification (RCV-LE/CA/01/C)
SID342	RXS, HIGHGAIN	RX sensitivity in high-gain mode with idle transmitter	-	-91	-	dBm	
SID343	PRXMAX	Maximum input power	-10	-1	-	dBm	RF-PHY Specification (RCV-LE/CA/06/C)
SID344	CI1	Co-channel interference, Wanted signal at -67 dBm and Interferer at F _{RX}	-	9	21	dB	RF-PHY Specification (RCV-LE/CA/03/C)

Note

3. This does not apply to the RF pins (ANT, XTALI, and XTALO). RF pins (ANT, XTALI, and XTALO) are tested for 500-V HBM.

Table 7. BLE Subsystem (continued)

Spec ID#	Parameter	Description	Min	Typ	Max	Units	Details/ Conditions
SID345	CI2	Adjacent channel interference Wanted signal at -67 dBm and Interferer at $F_{RX} \pm 1$ MHz	-	3	15	dB	RF-PHY Specification (RCV-LE/CA/03/C)
SID346	CI3	Adjacent channel interference Wanted signal at -67 dBm and Interferer at $F_{RX} \pm 2$ MHz	-	-29	-	dB	RF-PHY Specification (RCV-LE/CA/03/C)
SID347	CI4	Adjacent channel interference Wanted signal at -67 dBm and Interferer at $\geq F_{RX} \pm 3$ MHz	-	-39	-	dB	RF-PHY Specification (RCV-LE/CA/03/C)
SID348	CI5	Adjacent channel interference Wanted Signal at -67 dBm and Interferer at Image frequency (F_{IMAGE})	-	-20	-	dB	RF-PHY Specification (RCV-LE/CA/03/C)
SID349	CI3	Adjacent channel interference Wanted signal at -67 dBm and Interferer at Image frequency ($F_{IMAGE} \pm 1$ MHz)	-	-30	-	dB	RF-PHY Specification (RCV-LE/CA/03/C)
SID350	OBB1	Out-of-band blocking, Wanted signal at -67 dBm and Interferer at $F = 30$ -2000 MHz	-30	-27	-	dBm	RF-PHY Specification (RCV-LE/CA/04/C)
SID351	OBB2	Out-of-band blocking, Wanted signal at -67 dBm and Interferer at $F = 2,003$ -2,399 MHz	-35	-27	-	dBm	RF-PHY Specification (RCV-LE/CA/04/C)
SID352	OBB3	Out-of-band blocking, Wanted signal at -67 dBm and Interferer at $F = 2,484$ -2,997 MHz	-35	-27	-	dBm	RF-PHY Specification (RCV-LE/CA/04/C)
SID353	OBB4	Out-of-band blocking, Wanted signal at -67 dBm and Inter- ferer at $F = 3,000$ -12,750 MHz	-30	-27	-	dBm	RF-PHY Specification (RCV-LE/CA/04/C)
SID354	IMD	Intermodulation performance Wanted signal at -64 dBm and 1-Mbps BLE, third, fourth, and fifth offset channel	-50	-	-	dBm	RF-PHY Specification (RCV-LE/CA/05/C)
SID355	RXSE1	Receiver spurious emission 30 MHz to 1.0 GHz	-	-	-57	dBm	100-kHz measurement bandwidth ETSI EN300 328 V1.8.1
SID356	RXSE2	Receiver spurious emission 1.0 GHz to 12.75 GHz	-	-	-47	dBm	1-MHz measurement bandwidth ETSI EN300 328 V1.8.1
RF Transmitter Specifications							
SID357	TXP, ACC	RF power accuracy	-	± 1	-	dB	
SID358	TXP, RANGE	RF power control range	-	20	-	dB	
SID359	TXP, 0 dBm	Output power, 0-dB gain setting (PA7)	-	0	-	dBm	

Table 7. BLE Subsystem (continued)

Spec ID#	Parameter	Description	Min	Typ	Max	Units	Details/ Conditions
SID360	TXP, MAX	Output power, maximum power setting (PA10)	–	3	–	dBm	
SID361	TXP, MIN	Output power, minimum power setting (PA1)	–	–18	–	dBm	
SID362	F2AVG	Average frequency deviation for 10101010 pattern	185	–	–	kHz	RF-PHY Specification (TRM-LE/CA/05/C)
SID363	F1AVG	Average frequency deviation for 11110000 pattern	225	250	275	kHz	RF-PHY Specification (TRM-LE/CA/05/C)
SID364	EO	Eye opening = $\Delta F2AVG/\Delta F1AVG$	0.8	–	–		RF-PHY Specification (TRM-LE/CA/05/C)
SID365	FTX, ACC	Frequency accuracy	–150	–	150	kHz	RF-PHY Specification (TRM-LE/CA/06/C)
SID366	FTX, MAXDR	Maximum frequency drift	–50	–	50	kHz	RF-PHY Specification (TRM-LE/CA/06/C)
SID367	FTX, INITDR	Initial frequency drift	–20	–	20	kHz	RF-PHY Specification (TRM-LE/CA/06/C)
SID368	FTX,DR	Maximum drift rate	–20	–	20	kHz/ 50 μ s	RF-PHY Specification (TRM-LE/CA/06/C)
SID369	IBSE1	In-band spurious emission at 2-MHz offset	–	–	–20	dBm	RF-PHY Specification (TRM-LE/CA/03/C)
SID370	IBSE2	In-band spurious emission at ≥ 3 -MHz offset	–	–	–30	dBm	RF-PHY Specification (TRM-LE/CA/03/C)
SID371	TXSE1	Transmitter spurious emissions (average), <1.0 GHz	–	–	–55.5	dBm	FCC-15.247
SID372	TXSE2	Transmitter spurious emissions (average), >1.0 GHz	–	–	–41.5	dBm	FCC-15.247
RF Current Specification							
SID373	IRX	Receive current in normal mode	–	18.7	–	mA	
SID373A	IRX_RF	Receive current in normal mode	–	16.4	–	mA	Measured at V_{DDR}
SID374	IRX, HIGHGAIN	Receive current in high-gain mode	–	21.5	–	mA	
SID375	ITX, 3 dBm	TX current at 3-dBm setting (PA10)	–	20	–	mA	
SID376	ITX, 0 dBm	TX current at 0-dBm setting (PA7)	–	16.5	–	mA	
SID376A	ITX_RF, 0 dBm	TX current at 0-dBm setting (PA7)	–	15.6	–	mA	Measured at V_{DDR}
SID376B	ITX_RF, 0 dBm	TX current at 0 dBm excluding Balun loss	–	14.2	–	mA	Guaranteed by design simulation
SID377	ITX, -3 dBm	TX current at –3-dBm setting (PA4)	–	15.5	–	mA	
SID378	ITX, -6 dBm	TX current at –6-dBm setting (PA3)	–	14.5	–	mA	
SID379	ITX, -12 dBm	TX current at –12-dBm setting (PA2)	–	13.2	–	mA	
SID380	ITX, -18 dBm	TX current at –18-dBm setting (PA1)	–	12.5	–	mA	
SID380A	lavg_1sec, 0dBm	Average current at 1-second BLE connection interval	–	18.9	–	μ A	TXP: 0 dBm; ± 20 -ppm master and slave clock accuracy. For empty PDU exchange

Table 7. BLE Subsystem (continued)

Spec ID#	Parameter	Description	Min	Typ	Max	Units	Details/Conditions
SID380B	Iavg_4sec, 0dBm	Average current at 4-second BLE connection interval	–	6.25	–	μA	TXP: 0 dBm; ±20-ppm master and slave clock accuracy. For empty PDU exchange
General RF Specification							
SID381	FREQ	RF operating frequency	2400	–	2482	MHz	
SID382	CHBW	Channel spacing	–	2	–	MHz	
SID383	DR	On-air data rate	–	1000	–	kbps	
SID384	IDLE2TX	BLE Radio Idle to BLE Radio TX transition time	–	120	140	μs	
SID385	IDLE2RX	BLE Radio Idle to BLE Radio RX transition time	–	75	120	μs	
RSSI Specification							
SID386	RSSI, ACC	RSSI accuracy	–	±5	–	dB	
SID387	RSSI, RES	RSSI resolution	–	1	–	dB	
SID388	RSSI, PER	RSSI sample period	–	6	–	μs	

Device-Level Specifications

All specifications are valid for $-40\text{ }^{\circ}\text{C} \leq T_A \leq 105\text{ }^{\circ}\text{C}$, except where noted. Specifications are valid for 1.71 V to 5.5 V, except where noted.

Table 8. DC Specifications

Spec ID#	Parameter	Description	Min	Typ	Max	Units	Details/Conditions
SID6	V _{DD}	Power supply input voltage (V _{DDA} = V _{DDD} = V _{DD})	1.8	–	5.5	V	With regulator enabled
SID7	V _{DD}	Power supply input voltage unregulated (V _{DDA} = V _{DDD} = V _{DD})	1.71	1.8	1.89	V	Internally unregulated supply
SID8	V _{DDR}	Radio supply voltage (Radio on)	1.9	–	5.5	V	
SID8A	V _{DDR}	Radio supply voltage (Radio off)	1.71	–	5.5	V	
SID9	V _{CCD}	Digital regulator output voltage (for core logic)	–	1.8	–	V	
SID10	C _{VCCD}	Digital regulator output bypass capacitor	1	1.3	1.6	μF	X5R ceramic or better
Active Mode, V_{DD} = 1.71 V to 5.5 V							
SID13	I _{DD3}	Execute from flash; CPU at 3 MHz	–	1.7	–	mA	T = 25 °C, V _{DD} = 3.3 V
SID14	I _{DD4}	Execute from flash; CPU at 3 MHz	–	–	–	mA	T = –40 °C to 105 °C
SID15	I _{DD5}	Execute from flash; CPU at 6 MHz	–	2.5	–	mA	T = 25 °C, V _{DD} = 3.3 V
SID16	I _{DD6}	Execute from flash; CPU at 6 MHz	–	–	–	mA	T = –40 °C to 105 °C
SID17	I _{DD7}	Execute from flash; CPU at 12 MHz	–	4	–	mA	T = 25 °C, V _{DD} = 3.3 V
SID18	I _{DD8}	Execute from flash; CPU at 12 MHz	–	–	–	mA	T = –40 °C to 105 °C

Table 8. DC Specifications (continued)

Spec ID#	Parameter	Description	Min	Typ	Max	Units	Details/ Conditions
SID19	I _{DD9}	Execute from flash; CPU at 24 MHz	–	7.1	–	mA	T = 25 °C, V _{DD} = 3.3 V
SID20	I _{DD10}	Execute from flash; CPU at 24 MHz	–	–	–	mA	T = –40 °C to 105 °C
SID21	I _{DD11}	Execute from flash; CPU at 48 MHz	–	13.4	–	mA	T = 25 °C, V _{DD} = 3.3 V
SID22	I _{DD12}	Execute from flash; CPU at 48 MHz	–	–	–	mA	T = –40 °C to 105 °C
Sleep Mode, V_{DD} = 1.8 V to 5.5 V							
SID23	I _{DD13}	IMO on	–	–	–	mA	T = 25 °C, V _{DD} = 3.3 V, SYSCLK = 3 MHz
Sleep Mode, V_{DD} and V_{DDR} = 1.9 V to 5.5 V							
SID24	I _{DD14}	ECO on	–	–	–	mA	T = 25 °C, V _{DD} = 3.3 V, SYSCLK = 3 MHz
Deep-Sleep Mode, V_{DD} = 1.8 V to 3.6 V							
SID25	I _{DD15}	WDT with WCO on	–	1.3	–	µA	T = 25 °C, V _{DD} = 3.3 V
SID26	I _{DD16}	WDT with WCO on	–	–	–	µA	T = –40 °C to 105 °C
Deep-Sleep Mode, V_{DD} = 3.6 V to 5.5 V							
SID27	I _{DD17}	WDT with WCO on	–	–	–	µA	T = 25 °C, V _{DD} = 5 V
SID28	I _{DD18}	WDT with WCO on	–	–	–	µA	T = –40 °C to 105 °C
Deep-Sleep Mode, V_{DD} = 1.71 V to 1.89 V (Regulator Bypassed)							
SID29	I _{DD19}	WDT with WCO on	–	–	–	µA	T = 25 °C
SID30	I _{DD20}	WDT with WCO on	–	–	–	µA	T = –40 °C to 105 °C
Hibernate Mode, V_{DD} = 1.8 V to 3.6 V							
SID37	I _{DD27}	GPIO and reset active	–	150	–	nA	T = 25 °C, V _{DD} = 3.3 V
SID38	I _{DD28}	GPIO and reset active	–	–	–	nA	T = –40 °C to 105 °C
Hibernate Mode, V_{DD} = 3.6 V to 5.5 V							
SID39	I _{DD29}	GPIO and reset active	–	–	–	nA	T = 25 °C, V _{DD} = 5 V
SID40	I _{DD30}	GPIO and reset active	–	–	–	nA	T = –40 °C to 105 °C
Hibernate Mode, V_{DD} = 1.71 V to 1.89 V (Regulator Bypassed)							
SID41	I _{DD31}	GPIO and reset active	–	–	–	nA	T = 25 °C
SID42	I _{DD32}	GPIO and reset active	–	–	–	nA	T = –40 °C to 105 °C
Stop Mode, V_{DD} = 1.8 V to 3.6 V							
SID43	I _{DD33}	Stop-mode current (V _{DD})	–	20	–	nA	T = 25 °C, V _{DD} = 3.3 V
SID44	I _{DD34}	Stop-mode current (V _{DDR})	–	40	–	nA	T = 25 °C, V _{DDR} = 3.3 V
SID45	I _{DD35}	Stop-mode current (V _{DD})	–	–	–	nA	T = –40 °C to 105 °C
SID46	I _{DD36}	Stop-mode current (V _{DDR})	–	–	–	nA	T = –40 °C to 105 °C, V _{DDR} = 1.9 V to 3.6 V

Table 8. DC Specifications (continued)

Spec ID#	Parameter	Description	Min	Typ	Max	Units	Details/Conditions
Stop Mode, $V_{DD} = 3.6\text{ V to }5.5\text{ V}$							
SID47	I_{DD37}	Stop-mode current (V_{DD})	–	–	–	nA	$T = 25\text{ }^\circ\text{C}$, $V_{DD} = 5\text{ V}$
SID48	I_{DD38}	Stop-mode current (V_{DDR})	–	–	–	nA	$T = 25\text{ }^\circ\text{C}$, $V_{DDR} = 5\text{ V}$
SID49	I_{DD39}	Stop-mode current (V_{DD})	–	–	–	nA	$T = -40\text{ }^\circ\text{C to }105\text{ }^\circ\text{C}$
SID50	I_{DD40}	Stop-mode current (V_{DDR})	–	–	–	nA	$T = -40\text{ }^\circ\text{C to }105\text{ }^\circ\text{C}$
Stop Mode, $V_{DD} = 1.71\text{ V to }1.89\text{ V}$ (Regulator Bypassed)							
SID51	I_{DD41}	Stop-mode current (V_{DD})	–	–	–	nA	$T = 25\text{ }^\circ\text{C}$
SID52	I_{DD42}	Stop-mode current (V_{DD})	–	–	–	nA	$T = -40\text{ }^\circ\text{C to }105\text{ }^\circ\text{C}$

Table 9. AC Specifications

Spec ID#	Parameter	Description	Min	Typ	Max	Units	Details/Conditions
SID53	F_{CPU}	CPU frequency	DC	–	48	MHz	$1.71\text{ V} \leq V_{DD} \leq 5.5\text{ V}$
SID54	T_{SLEEP}	Wakeup from Sleep mode	–	0	–	μs	Guaranteed by characterization
SID55	$T_{DEEPSLEEP}$	Wakeup from Deep-Sleep mode	–	–	25	μs	24-MHz IMO. Guaranteed by characterization
SID56	$T_{HIBERNATE}$	Wakeup from Hibernate mode	–	–	2	ms	Guaranteed by characterization
SID57	T_{STOP}	Wakeup from Stop mode	–	–	2	ms	Guaranteed by characterization

GPIO

Table 10. GPIO DC Specifications

Spec ID#	Parameter	Description	Min	Typ	Max	Units	Details/Conditions
SID58	V_{IH}	Input voltage HIGH threshold	$0.7 \times V_{DD}$	–	–	V	CMOS input
SID59	V_{IL}	Input voltage LOW threshold	–	–	$0.3 \times V_{DD}$	V	CMOS input
SID60	V_{IH}	LVTTL input, $V_{DD} < 2.7\text{ V}$	$0.7 \times V_{DD}$	–	–	V	
SID61	V_{IL}	LVTTL input, $V_{DD} < 2.7\text{ V}$	–	–	$0.3 \times V_{DD}$	V	
SID62	V_{IH}	LVTTL input, $V_{DD} \geq 2.7\text{ V}$	2.0	–	–	V	
SID63	V_{IL}	LVTTL input, $V_{DD} \geq 2.7\text{ V}$	–	–	0.8	V	
SID64	V_{OH}	Output voltage HIGH level	$V_{DD} - 0.6$	–	–	V	$I_{OH} = 4\text{ mA}$ at 3.3- V_{DD}
SID65	V_{OH}	Output voltage HIGH level	$V_{DD} - 0.5$	–	–	V	$I_{OH} = 1\text{ mA}$ at 1.8- V_{DD}
SID66	V_{OL}	Output voltage LOW level	–	–	0.6	V	$I_{OL} = 8\text{ mA}$ at 3.3- V_{DD}
SID67	V_{OL}	Output voltage LOW level	–	–	0.6	V	$I_{OL} = 4\text{ mA}$ at 1.8- V_{DD}

Note

- V_{IH} must not exceed $V_{DD} + 0.2\text{ V}$.

Table 10. GPIO DC Specifications (continued)

Spec ID#	Parameter	Description	Min	Typ	Max	Units	Details/Conditions
SID68	V _{OL}	Output voltage LOW level	–	–	0.4	V	I _{OL} = 3 mA at 3.3-V V _{DD}
SID69	R _{PULLUP}	Pull-up resistor	3.5	5.6	8.5	kΩ	
SID70	R _{PULLDOWN}	Pull-down resistor	3.5	5.6	8.5	kΩ	
SID71	I _{IL}	Input leakage current (absolute value)	–	–	2	nA	25 °C, V _{DD} = 3.3 V
SID72	I _{IL_CTBM}	Input leakage on CTBm input pins	–	–	4	nA	
SID73	C _{IN}	Input capacitance	–	–	7	pF	
SID74	V _{HYSTTL}	Input hysteresis LVTTTL	25	40		mV	V _{DD} > 2.7 V
SID75	V _{HYS CMOS}	Input hysteresis CMOS	0.05 × V _{DD}	–	–	mV	
SID76	I _{DIODE}	Current through protection diode to V _{DD} /V _{SS}	–	–	100	μA	Except for overvoltage-tolerant pins (P5.0 and P5.1)
SID77	I _{TOT_GPIO}	Maximum total source or sink chip current	–	–	200	mA	

Table 11. GPIO AC Specifications

Spec ID#	Parameter	Description	Min	Typ	Max	Units	Details/Conditions
SID78	T _{RISE F}	Rise time in Fast-Strong mode	2	–	12	ns	3.3-V V _{DD} , C _{LOAD} = 25 pF
SID79	T _{FALL F}	Fall time in Fast-Strong mode	2	–	12	ns	3.3-V V _{DD} , C _{LOAD} = 25 pF
SID80	T _{RISE S}	Rise time in Slow-Strong mode	10	–	60	ns	3.3-V V _{DD} , C _{LOAD} = 25 pF
SID81	T _{FALL S}	Fall time in Slow-Strong mode	10	–	60	ns	3.3-V V _{DD} , C _{LOAD} = 25 pF
SID82	F _{GPIO OUT1}	GPIO Fout; 3.3 V ≤ V _{DD} ≤ 5.5 V. Fast-Strong mode	–	–	33	MHz	90/10%, 25-pF load, 60/40 duty cycle
SID83	F _{GPIO OUT2}	GPIO Fout; 1.7 V ≤ V _{DD} ≤ 3.3 V. Fast-Strong mode	–	–	16.7	MHz	90/10%, 25-pF load, 60/40 duty cycle
SID84	F _{GPIO OUT3}	GPIO Fout; 3.3 V ≤ V _{DD} ≤ 5.5 V. Slow-Strong mode	–	–	7	MHz	90/10%, 25-pF load, 60/40 duty cycle
SID85	F _{GPIO OUT4}	GPIO Fout; 1.7 V ≤ V _{DD} ≤ 3.3 V. Slow-Strong mode	–	–	3.5	MHz	90/10%, 25-pF load, 60/40 duty cycle
SID86	F _{GPIO IN}	GPIO input operating frequency. 1.71 V ≤ V _{DD} ≤ 5.5 V	–	–	48	MHz	90/10% V _{IO}

Table 12. OVT GPIO DC Specifications (P5_0 and P5_1 Only)

Spec ID#	Parameter	Description	Min	Typ	Max	Units	Details/Conditions
SID71A	I _{IL}	Input leakage (absolute value). V _{IH} > V _{DD}			10	μA	25 °C, V _{DD} = 0 V, V _{IH} = 3.0 V
SID66A	V _{OL}	Output voltage LOW level	–	–	0.4	V	I _{OL} = 20 mA, V _{DD} > 2.9 V

Table 13. OVT GPIO AC Specifications (P5_0 and P5_1 Only)

Spec ID#	Parameter	Description	Min	Typ	Max	Units	Details/ Conditions
SID78A	T _{RISE_OVFS}	Output rise time in Fast-Strong mode	1.5	–	12	ns	25-pF load, 10%–90%, V _{DD} =3.3 V
SID79A	T _{FALL_OVFS}	Output fall time in Fast-Strong mode	1.5	–	12	ns	25-pF load, 10%–90%, V _{DD} =3.3 V
SID80A	T _{RISESS}	Output rise time in Slow-Strong mode	10	–	60	ns	25-pF load, 10%–90%, V _{DD} = 3.3 V
SID81A	T _{FALLSS}	Output fall time in Slow-Strong mode	10	–	60	ns	25-pF load, 10%–90%, V _{DD} = 3.3 V
SID82A	F _{GPIOUT1}	GPIO F _{OUT} ; 3.3 V ≤ V _{DD} ≤ 5.5 V Fast-Strong mode	–	–	24	MHz	90/10%, 25-pF load, 60/40 duty cycle
SID83A	F _{GPIOUT2}	GPIO F _{OUT} ; 1.71 V ≤ V _{DD} ≤ 3.3 V Fast-Strong mode	–	–	16	MHz	90/10%, 25-pF load, 60/40 duty cycle

XRES

Table 14. XRES DC Specifications

Spec ID#	Parameter	Description	Min	Typ	Max	Units	Details/ Conditions
SID87	V _{IH}	Input voltage HIGH threshold	0.7 × V _{DDD}	–	–	V	CMOS input
SID88	V _{IL}	Input voltage LOW threshold	–	–	0.3 × V _{DDD}	V	CMOS input
SID89	R _{PULLUP}	Pull-up resistor	3.5	5.6	8.5	kΩ	
SID90	C _{IN}	Input capacitance	–	3	–	pF	
SID91	V _{HYSXRES}	Input voltage hysteresis	–	100	–	mV	
SID92	I _{DIODE}	Current through protection diode to V _{DD} /V _{SS}	–	–	100	μA	

Table 15. XRES AC Specifications

Spec ID#	Parameter	Description	Min	Typ	Max	Units	Details/ Conditions
SID93	T _{RESETWIDTH}	Reset pulse width	1	–	–	μs	

Analog Peripherals

Temperature Sensor

Table 16. Temperature Sensor Specifications

Spec ID#	Parameter	Description	Min	Typ	Max	Units	Details/Conditions
SID155	T _{SENSACC}	Temperature sensor accuracy	-5	±1	5	°C	-40 to +85 °C

SAR ADC

Table 17. SAR ADC DC Specifications

Spec ID#	Parameter	Description	Min	Typ	Max	Units	Details/Conditions
SID156	A_RES	Resolution	-	-	12	bits	
SID157	A_CHNIS_S	Number of channels – single-ended	-	-	8		8 full-speed
SID158	A-CHNKS_D	Number of channels – differential	-	-	4		Differential inputs use neighboring I/O
SID159	A-MONO	Monotonicity	-	-			Yes
SID160	A_GAINERR	Gain error	-	-	±0.1	%	With external reference
SID161	A_OFFSET	Input offset voltage	-	-	2	mV	Measured with 1-V V _{REF}
SID162	A_ISAR	Current consumption	-	-	1	mA	
SID163	A_VINS	Input voltage range – single-ended	V _{SS}	-	V _{DDA}	V	
SID164	A_VIND	Input voltage range – differential	V _{SS}	-	V _{DDA}	V	
SID165	A_INRES	Input resistance	-	-	2.2	kΩ	
SID166	A_INCAP	Input capacitance	-	-	10	pF	
SID312	VREFSAR	Trimmed internal reference to SAR	-1	-	1	%	Percentage of V _{bg} (1.024 V)

Table 18. SAR ADC AC Specifications

Spec ID#	Parameter	Description	Min	Typ	Max	Units	Details/Conditions
SID167	A_PSRR	Power supply rejection ratio	70	-	-	dB	Measured at 1-V reference
SID168	A_CMRR	Common-mode rejection ratio	66	-	-	dB	
SID169	A_SAMP	Sample rate	-	-	1	Msps	
SID313	F _{sarintref}	SAR operating speed without external reference bypass	-	-	100	Ksps	12-bit resolution
SID170	A_SNR	Signal-to-noise ratio (SNR)	65	-	-	dB	F _{IN} = 10 kHz
SID171	A_BW	Input bandwidth without aliasing	-	-	A_SAMP/2	kHz	
SID172	A_INL	Integral nonlinearity (INL). V _{DD} = 1.71 V to 5.5 V, 1 Msps	-1.7	-	2	LSB	V _{REF} = 1 V to V _{DD}
SID173	A_INL	Integral nonlinearity. V _{DDD} = 1.71 V to 3.6 V, 1 Msps	-1.5	-	1.7	LSB	V _{REF} = 1.71 V to V _{DD}
SID174	A_INL	Integral nonlinearity. V _{DD} = 1.71 V to 5.5 V, 500 Ksps	-1.5	-	1.7	LSB	V _{REF} = 1 V to V _{DD}

Table 18. SAR ADC AC Specifications (continued)

Spec ID#	Parameter	Description	Min	Typ	Max	Units	Details/ Conditions
SID175	A_DNL	Differential nonlinearity (DNL). $V_{DD} = 1.71\text{ V to }5.5\text{ V}$, 1 Msps	-1	-	2.2	LSB	$V_{REF} = 1\text{ V to }V_{DD}$
SID176	A_DNL	Differential nonlinearity. $V_{DD} = 1.71\text{ V to }3.6\text{ V}$, 1 Msps	-1	-	2	LSB	$V_{REF} = 1.71\text{ V to }V_{DD}$
SID177	A_DNL	Differential nonlinearity. $V_{DD} = 1.71\text{ V to }5.5\text{ V}$, 500 Ksps	-1	-	2.2	LSB	$V_{REF} = 1\text{ V to }V_{DD}$
SID178	A_THD	Total harmonic distortion	-	-	-65	dB	$F_{IN} = 10\text{ kHz}$

CSD

Table 19. CSD Block Specifications

Spec ID#	Parameter	Description	Min	Typ	Max	Units	Details/ Conditions
SID179	VCSD	Voltage range of operation	1.71	-	5.5	V	
SID180	IDAC1	DNL for 8-bit resolution	-1	-	1	LSB	
SID181	IDAC1	INL for 8-bit resolution	-3	-	3	LSB	
SID182	IDAC2	DNL for 7-bit resolution	-1	-	1	LSB	
SID183	IDAC2	INL for 7-bit resolution	-3	-	3	LSB	
SID184	SNR	Ratio of counts of finger to noise	5	-	-	Ratio	Capacitance range of 9 pF to 35 pF; 0.1-pF sensitivity. Radio is not operating during the scan
SID185	IDAC1_CRT1	Output current of IDAC1 (8 bits) in HIGH range	-	612	-	μA	
SID186	IDAC1_CRT2	Output current of IDAC1 (8 bits) in LOW range	-	306	-	μA	
SID187	IDAC2_CRT1	Output current of IDAC2 (7 bits) in HIGH range	-	305	-	μA	
SID188	IDAC2_CRT2	Output current of IDAC2 (7 bits) in LOW range	-	153	-	μA	

Digital Peripherals

4x TCPWM

Table 20. Timer DC Specifications

Spec ID	Parameter	Description	Min	Typ	Max	Units	Details/Conditions
SID189	I _{TIM1}	Block current consumption at 3 MHz	–	–	42	μA	16-bit timer, 85 °C
SID189A			–	–	46	μA	16-bit timer, 105 °C
SID190	I _{TIM2}	Block current consumption at 12 MHz	–	–	130	μA	16-bit timer, 85 °C
SID190A			–	–	137	μA	16-bit timer, 105 °C
SID191	I _{TIM3}	Block current consumption at 48 MHz	–	–	535	μA	16-bit timer, 85 °C
SID191A			–	–	560	μA	16-bit timer, 105 °C

Table 21. Timer AC Specifications

Spec ID	Parameter	Description	Min	Typ	Max	Units	Details/Conditions
SID192	T _{TIMFREQ}	Operating frequency	F _{CLK}	–	48	MHz	
SID193	T _{CAPWINT}	Capture pulse width (internal)	2 × T _{CLK}	–	–	ns	
SID194	T _{CAPWEXT}	Capture pulse width (external)	2 × T _{CLK}	–	–	ns	
SID195	T _{TIMRES}	Timer resolution	T _{CLK}	–	–	ns	
SID196	T _{TENWIDINT}	Enable pulse width (internal)	2 × T _{CLK}	–	–	ns	
SID197	T _{TENWIDEXT}	Enable pulse width (external)	2 × T _{CLK}	–	–	ns	
SID198	T _{TIMRESWINT}	Reset pulse width (internal)	2 × T _{CLK}	–	–	ns	
SID199	T _{TIMRESEXT}	Reset pulse width (external)	2 × T _{CLK}	–	–	ns	

Counter

Table 22. Counter DC Specifications

Spec ID	Parameter	Description	Min	Typ	Max	Units	Details/Conditions
SID200	I _{CTR1}	Block current consumption at 3 MHz	–	–	42	μA	16-bit timer, 85 °C
SID200A			–	–	46	μA	16-bit timer, 105 °C
SID201	I _{CTR2}	Block current consumption at 12 MHz	–	–	130	μA	16-bit timer, 85 °C
SID201A			–	–	137	μA	16-bit timer, 105 °C
SID202	I _{CTR3}	Block current consumption at 48 MHz	–	–	535	μA	16-bit timer, 85 °C
SID202A			–	–	560	μA	16-bit timer, 105 °C

Table 23. Counter AC Specifications

Spec ID	Parameter	Description	Min	Typ	Max	Units	Details/Conditions
SID203	T _{CTRFREQ}	Operating frequency	F _{CLK}	–	48	MHz	
SID204	T _{CTRPWINT}	Capture pulse width (internal)	2 × T _{CLK}	–	–	ns	
SID205	T _{CTRPWEXT}	Capture pulse width (external)	2 × T _{CLK}	–	–	ns	
SID206	T _{CTRES}	Counter resolution	T _{CLK}	–	–	ns	
SID207	T _{CENWIDINT}	Enable pulse width (internal)	2 × T _{CLK}	–	–	ns	
SID208	T _{CENWIDEXT}	Enable pulse width (external)	2 × T _{CLK}	–	–	ns	
SID209	T _{CTRRESWINT}	Reset pulse width (internal)	2 × T _{CLK}	–	–	ns	
SID210	T _{CTRRESWEXT}	Reset pulse width (external)	2 × T _{CLK}	–	–	ns	

Pulse Width Modulation (PWM)

Table 24. PWM DC Specifications

Spec ID	Parameter	Description	Min	Typ	Max	Units	Details/Conditions
SID211	I _{PWM1}	Block current consumption at 3 MHz	–	–	42	μA	16-bit timer, 85 °C
SID211A			–	–	46	μA	16-bit timer, 105 °C
SID212	I _{PWM2}	Block current consumption at 12 MHz	–	–	130	μA	16-bit timer, 85 °C
SID212A			–	–	137	μA	16-bit timer, 105 °C
SID213	I _{PWM3}	Block current consumption at 48 MHz	–	–	535	μA	16-bit timer, 85 °C
SID213A			–	–	560	μA	16-bit timer, 105 °C

Table 25. PWM AC Specifications

Spec ID	Parameter	Description	Min	Typ	Max	Units	Details/Conditions
SID214	T _{PWMFREQ}	Operating frequency	F _{CLK}	–	48	MHz	
SID215	T _{PWMPWINT}	Pulse width (internal)	2 × T _{CLK}	–	–	ns	
SID216	T _{PWMEXT}	Pulse width (external)	2 × T _{CLK}	–	–	ns	
SID217	T _{PWMKILLINT}	Kill pulse width (internal)	2 × T _{CLK}	–	–	ns	
SID218	T _{PWMKILLEXT}	Kill pulse width (external)	2 × T _{CLK}	–	–	ns	
SID219	T _{PWMEINT}	Enable pulse width (internal)	2 × T _{CLK}	–	–	ns	
SID220	T _{PWMENEXT}	Enable pulse width (external)	2 × T _{CLK}	–	–	ns	
SID221	T _{PWMRESWINT}	Reset pulse width (internal)	2 × T _{CLK}	–	–	ns	
SID222	T _{PWMRESWEXT}	Reset pulse width (external)	2 × T _{CLK}	–	–	ns	

I²C

Table 26. I²C DC Specifications

Spec ID	Parameter	Description	Min	Typ	Max	Units	Details/Conditions
SID223	I _{I2C1}	Block current consumption at 100 kHz	–	–	50	μA	
SID224	I _{I2C2}	Block current consumption at 400 kHz	–	–	155	μA	
SID225	I _{I2C3}	Block current consumption at 1 Mbps	–	–	390	μA	
SID226	I _{I2C4}	I ² C enabled in Deep-Sleep mode	–	–	1.4	μA	

Table 27. Fixed I²C AC Specifications

Spec ID	Parameter	Description	Min	Typ	Max	Units	Details/Conditions
SID227	F _{I2C1}	Bit rate	–	–	1	Mbps	

LCD Direct Drive

Table 28. LCD Direct Drive DC Specifications

Spec ID	Parameter	Description	Min	Typ	Max	Units	Details/Conditions
SID228	I _{LCDLOW}	Operating current in low-power mode	–	17.5	–	μA	16 × 4 small-segment display at 50 Hz
SID229	C _{LCDCAP}	LCD capacitance per segment/common driver	–	500	5000	pF	
SID230	LCD _{OFFSET}	Long-term segment offset	–	20	–	mV	
SID231	I _{LCDOP1}	LCD system operating current. V _{bias} = 5 V	–	2	–	mA	32 × 4 segments. 50 Hz. 25 °C
SID232	I _{LCDOP2}	LCD system operating current. V _{bias} = 3.3 V	–	2	–	mA	32 × 4 segments. 50 Hz. 25 °C

Table 29. LCD Direct Drive AC Specifications

Spec ID	Parameter	Description	Min	Typ	Max	Units	Details/Conditions
SID233	F _{LCD}	LCD frame rate	10	50	150	Hz	

Table 30. Fixed UART DC Specifications

Spec ID	Parameter	Description	Min	Typ	Max	Units	Details/Conditions
SID234	I _{UART1}	Block current consumption at 100 kbps	–	–	55	μA	
SID235	I _{UART2}	Block current consumption at 1000 kbps	–	–	312	μA	

Table 31. Fixed UART AC Specifications

Spec ID	Parameter	Description	Min	Typ	Max	Units	Details/Conditions
SID236	F _{UART}	Bit rate	–	–	1	Mbps	

SPI Specifications

Table 32. Fixed SPI DC Specifications

Spec ID	Parameter	Description	Min	Typ	Max	Units	Details/Conditions
SID237	I _{SPI1}	Block current consumption at 1 Mbps	–	–	360	μA	
SID238	I _{SPI2}	Block current consumption at 4 Mbps	–	–	560	μA	
SID239	I _{SPI3}	Block current consumption at 8 Mbps	–	–	600	μA	

Table 33. Fixed SPI AC Specifications

Spec ID	Parameter	Description	Min	Typ	Max	Units	Details/Conditions
SID240	F _{SPI}	SPI operating frequency (master; 6x oversampling)	–	–	8	MHz	

Table 34. Fixed SPI Master Mode AC Specifications

Spec ID	Parameter	Description	Min	Typ	Max	Units	Details/Conditions
SID241	T _{D_{MO}}	MOSI valid after SCLK driving edge	–	–	18	ns	
SID242	T _{D_{SI}}	MISO valid before SCLK capturing edge. Full clock, late MISO sampling used	20	–	–	ns	Full clock, late MISO sampling
SID243	T _{H_{MO}}	Previous MOSI data hold time	0	–	–	ns	Referred to Slave capturing edge

Table 35. Fixed SPI Slave Mode AC Specifications

Spec ID	Parameter	Description	Min	Typ	Max	Units
SID244	T _{D_{MI}}	MOSI valid before SCLK capturing edge	40	–	–	ns
SID245	T _{D_{SO}}	MISO valid after SCLK driving edge	–	–	42 + 3 × T _{SCB}	ns
SID246	T _{D_{SO_ext}}	MISO Valid after SCLK driving edge in external clock mode. V _{DD} < 3.0 V	–	–	50	ns
SID247	T _{H_{SO}}	Previous MISO data hold time	0	–	–	ns
SID248	T _{SSEL_{SCK}}	SSEL valid to first SCK valid edge	100	–	–	ns

Memory

Table 36. Flash DC Specifications

Spec ID	Parameter	Description	Min	Typ	Max	Units	Details/Conditions
SID249	V _{PE}	Erase and program voltage	1.71	–	5.5	V	
SID309	T _{WS48}	Number of Wait states at 32–48 MHz	2	–	–		CPU execution from flash
SID310	T _{WS32}	Number of Wait states at 16–32 MHz	1	–	–		CPU execution from flash
SID311	T _{WS16}	Number of Wait states for 0–16 MHz	0	–	–		CPU execution from flash

Table 37. Flash AC Specifications

Spec ID	Parameter	Description	Min	Typ	Max	Units	Details/Conditions
SID250	T _{ROWWRITE} ^[5]	Row (block) write time (erase and program)	–	–	20	ms	Row (block) = 128 bytes
SID251	T _{ROWERASE} ^[5]	Row erase time	–	–	13	ms	
SID252	T _{ROWPROGRAM} ^[5]	Row program time after erase	–	–	7	ms	
SID253	T _{BULKERASE} ^[5]	Bulk erase time (128 KB)	–	–	35	ms	
SID254	T _{DEVPROG} ^[5]	Total device program time	–	–	25	seconds	
SID255	F _{END}	Flash endurance	100 K	–	–	cycles	
SID256	F _{RET}	Flash retention. T _A ≤ 55 °C, 100-K P/E cycles	20	–	–	years	
SID257	F _{RET2}	Flash retention. T _A ≤ 85 °C, 10-K P/E cycles	10	–	–	years	
SID257A	F _{RET3}	Flash retention. T _A ≤ 105 °C, 10-K P/E cycles	3	–	–	years	For T _A ≥ 85 °C

System Resources

Power-on-Reset (POR)

Table 38. POR DC Specifications

Spec ID	Parameter	Description	Min	Typ	Max	Units	Details/Conditions
SID258	V _{RISEIPOR}	Rising trip voltage	0.80	–	1.45	V	
SID259	V _{FALLIPOR}	Falling trip voltage	0.75	–	1.40	V	
SID260	V _{IPORHYST}	Hysteresis	15	–	200	mV	

Table 39. POR AC Specifications

Spec ID	Parameter	Description	Min	Typ	Max	Units	Details/Conditions
SID264	T _{PPOR_TR}	Precision power-on reset (PPOR) response time in Active and Sleep modes	–	–	1	µs	

Note

- It can take as much as 20 ms to write to flash. During this time, the device should not be reset, or flash operations will be interrupted and cannot be relied on to have completed. Reset sources include the XRES pin, software resets, CPU lockup states and privilege violations, improper power supply levels, and watchdogs. Make certain that these are not inadvertently activated.

Table 40. Brown-Out Detect

Spec ID#	Parameter	Description	Min	Typ	Max	Units	Details/ Conditions
SID261	V _{FALLPPOR}	BOD trip voltage in Active and Sleep modes	1.64	–	–	V	
SID262	V _{FALLDPSLP}	BOD trip voltage in Deep Sleep	1.4	–	–	V	

Table 41. Hibernate Reset

Spec ID#	Parameter	Description	Min	Typ	Max	Units	Details/ Conditions
SID263	V _{HBRTRIP}	BOD trip voltage in Hibernate	1.1	–	–	V	

Voltage Monitors (LVD)

Table 42. Voltage Monitor DC Specifications

Spec ID	Parameter	Description	Min	Typ	Max	Units	Details/ Conditions
SID265	V _{LVI1}	LVI_A/D_SEL[3:0] = 0000b	1.71	1.75	1.79	V	
SID266	V _{LVI2}	LVI_A/D_SEL[3:0] = 0001b	1.76	1.80	1.85	V	
SID267	V _{LVI3}	LVI_A/D_SEL[3:0] = 0010b	1.85	1.90	1.95	V	
SID268	V _{LVI4}	LVI_A/D_SEL[3:0] = 0011b	1.95	2.00	2.05	V	
SID269	V _{LVI5}	LVI_A/D_SEL[3:0] = 0100b	2.05	2.10	2.15	V	
SID270	V _{LVI6}	LVI_A/D_SEL[3:0] = 0101b	2.15	2.20	2.26	V	
SID271	V _{LVI7}	LVI_A/D_SEL[3:0] = 0110b	2.24	2.30	2.36	V	
SID272	V _{LVI8}	LVI_A/D_SEL[3:0] = 0111b	2.34	2.40	2.46	V	
SID273	V _{LVI9}	LVI_A/D_SEL[3:0] = 1000b	2.44	2.50	2.56	V	
SID274	V _{LVI10}	LVI_A/D_SEL[3:0] = 1001b	2.54	2.60	2.67	V	
SID275	V _{LVI11}	LVI_A/D_SEL[3:0] = 1010b	2.63	2.70	2.77	V	
SID276	V _{LVI12}	LVI_A/D_SEL[3:0] = 1011b	2.73	2.80	2.87	V	
SID277	V _{LVI13}	LVI_A/D_SEL[3:0] = 1100b	2.83	2.90	2.97	V	
SID278	V _{LVI14}	LVI_A/D_SEL[3:0] = 1101b	2.93	3.00	3.08	V	
SID279	V _{LVI15}	LVI_A/D_SEL[3:0] = 1110b	3.12	3.20	3.28	V	
SID280	V _{LVI16}	LVI_A/D_SEL[3:0] = 1111b	4.39	4.50	4.61	V	
SID281	LVI_IDD	Block current	–	–	100	μA	

Table 43. Voltage Monitor AC Specifications

Spec ID	Parameter	Description	Min	Typ	Max	Units	Details/ Conditions
SID282	T _{MONTRIP}	Voltage monitor trip time	–	–	1	μs	

SWD Interface

Table 44. SWD Interface Specifications

Spec ID	Parameter	Description	Min	Typ	Max	Units	Details/Conditions
SID283	F_SWCLK1	$3.3\text{ V} \leq V_{DD} \leq 5.5\text{ V}$	–	–	14	MHz	SWDCLK \leq 1/3 CPU clock frequency
SID284	F_SWCLK2	$1.71\text{ V} \leq V_{DD} \leq 3.3\text{ V}$	–	–	7	MHz	SWDCLK \leq 1/3 CPU clock frequency
SID285	T_SWDI_SETUP	$T = 1/f\text{ SWDCLK}$	$0.25 \times T$	–	–	ns	
SID286	T_SWDI_HOLD	$T = 1/f\text{ SWDCLK}$	$0.25 \times T$	–	–	ns	
SID287	T_SWDO_VALID	$T = 1/f\text{ SWDCLK}$	–	–	$0.5 \times T$	ns	
SID288	T_SWDO_HOLD	$T = 1/f\text{ SWDCLK}$	1	–	–	ns	

Internal Main Oscillator

Table 45. IMO DC Specifications

Spec ID	Parameter	Description	Min	Typ	Max	Units	Details/Conditions
SID289	I _{IMO1}	IMO operating current at 48 MHz	–	–	1000	μA	
SID290	I _{IMO2}	IMO operating current at 24 MHz	–	–	325	μA	
SID291	I _{IMO3}	IMO operating current at 12 MHz	–	–	225	μA	
SID292	I _{IMO4}	IMO operating current at 6 MHz	–	–	180	μA	
SID293	I _{IMO5}	IMO operating current at 3 MHz	–	–	150	μA	

Table 46. IMO AC Specifications

Spec ID	Parameter	Description	Min	Typ	Max	Units	Details/Conditions
SID296	F _{IMOTOL3}	Frequency variation from 3 to 48 MHz	–	–	± 2	%	With API-called calibration
SID297	F _{IMOTOL3}	IMO startup time	–	12	–	μs	

Internal Low-Speed Oscillator

Table 47. ILO DC Specifications

Spec ID	Parameter	Description	Min	Typ	Max	Units	Details/Conditions
SID298	I _{ILO2}	ILO operating current at 32 kHz	–	0.3	1.05	μA	Guaranteed by design

Table 48. ILO AC Specifications

Spec ID	Parameter	Description	Min	Typ	Max	Units	Details/Conditions
SID299	T _{STARTILO1}	ILO startup time	–	–	2	ms	
SID300	F _{ILOTRIM1}	32-kHz trimmed frequency	15	32	50	kHz	

Table 49. External Clock Specifications

Spec ID	Parameter	Description	Min	Typ	Max	Units	Details/Conditions
SID301	ExtClkFreq	External clock input frequency	0	–	48	MHz	CMOS input level only. TTL input is not supported
SID302	ExtClkDuty	Duty cycle; measured at $V_{DD}/2$	45	–	55	%	CMOS input level only. TTL input is not supported

Table 50. ECO Specifications

Spec ID#	Parameter	Description	Min	Typ	Max	Units	Details/ Conditions
SID389	F _{ECO}	Crystal frequency	–	24	–	MHz	
SID390	F _{TOL}	Frequency tolerance	–50	–	50	ppm	
SID391	ESR	Equivalent series resistance	–	–	60	Ω	
SID392	PD	Drive level	–	–	100	μW	
SID393	T _{START1}	Startup time (Fast Charge on)	–	–	850	μs	
SID394	T _{START2}	Startup time (Fast Charge off)	–	–	3	ms	
SID395	C _L	Load capacitance	–	8	–	pF	
SID396	C ₀	Shunt capacitance	–	1.1	–	pF	
SID397	I _{ECO}	Operating current	–	1400	–	μA	Includes LDO+BG current

Table 51. WCO Specifications

Spec ID#	Parameter	Description	Min	Typ	Max	Units	Details/ Conditions
SID398	F _{WCO}	Crystal frequency	–	32.768	–	kHz	
SID399	F _{TOL}	Frequency tolerance	–	50	–	ppm	
SID400	ESR	Equivalent series resistance	–	50	–	kΩ	
SID401	PD	Drive level	–	–	1	μW	
SID402	T _{START}	Startup time	–	–	500	ms	
SID403	C _L	Crystal load capacitance	6	–	12.5	pF	
SID404	C ₀	Crystal shunt capacitance	–	1.35	–	pF	
SID405	I _{WCO1}	Operating current (high-power mode)	–	–	8	μA	
SID406	I _{WCO2}	Operating current (low-power mode)	–	–	1	μA	85 °C
SID406A			–	–	2.6	μA	105 °C

Ordering Information

The CYBL10X6X part numbers and features are listed in the following table.

Part Number	CPU Speed (MHz)	Flash Size (KB)	CapSense	SCB	TCPWM	12-Bit SAR ADC	I ² S	PWM	LCD	Package
CYBL10161-56LQXI	48	128	No	1	2	1 Msps	No	No	No	56-QFN
CYBL10162-56LQXI	48	128	No	2	4	1 Msps	No	4	No	56-QFN
CYBL10163-56LQXI	48	128	No	2	4	1 Msps	Yes	No	No	56-QFN
CYBL10461-56LQXI	48	128	Yes	2	4	1 Msps	No	No	No	56-QFN
CYBL10462-56LQXI	48	128	Yes	2	4	1 Msps	Yes	No	No	56-QFN
CYBL10463-56LQXI	48	128	Yes	2	4	1 Msps	No	No	Yes	56-QFN
CYBL10561-56LQXI	48	128	Yes (Gestures)	2	4	1 Msps	No	No	No	56-QFN
CYBL10562-56LQXI	48	128	Yes (Gestures)	2	4	1 Msps	Yes	1	No	56-QFN
CYBL10563-56LQXI	48	128	Yes (Gestures)	2	4	1 Msps	Yes	1	Yes	56-QFN
CYBL10563-68FNXIT	48	128	Yes (Gestures)	2	4	1 Msps	Yes	1	Yes	68-WLCSP
CYBL10563-56LQXQ ^[6]	48	128	Yes (Gestures)	2	4	1 Msps	Yes	1	Yes	56-QFN
CYBL10563-68FLXIT ^[7]	48	128	Yes (Gestures)	2	4	1 Msps	Yes	1	Yes	68-Thin WLCSP
CYBL10999-56LQXI	Contact Sales									

Note

6. This part is available as Engineering Sample.
7. This part is available as Engineering Sample (CYBL10563-68FLXIEST).

Part Numbering Conventions

The part numbers are of the form CYBL10ABC-DEFGHIT where the fields are defined as follows.

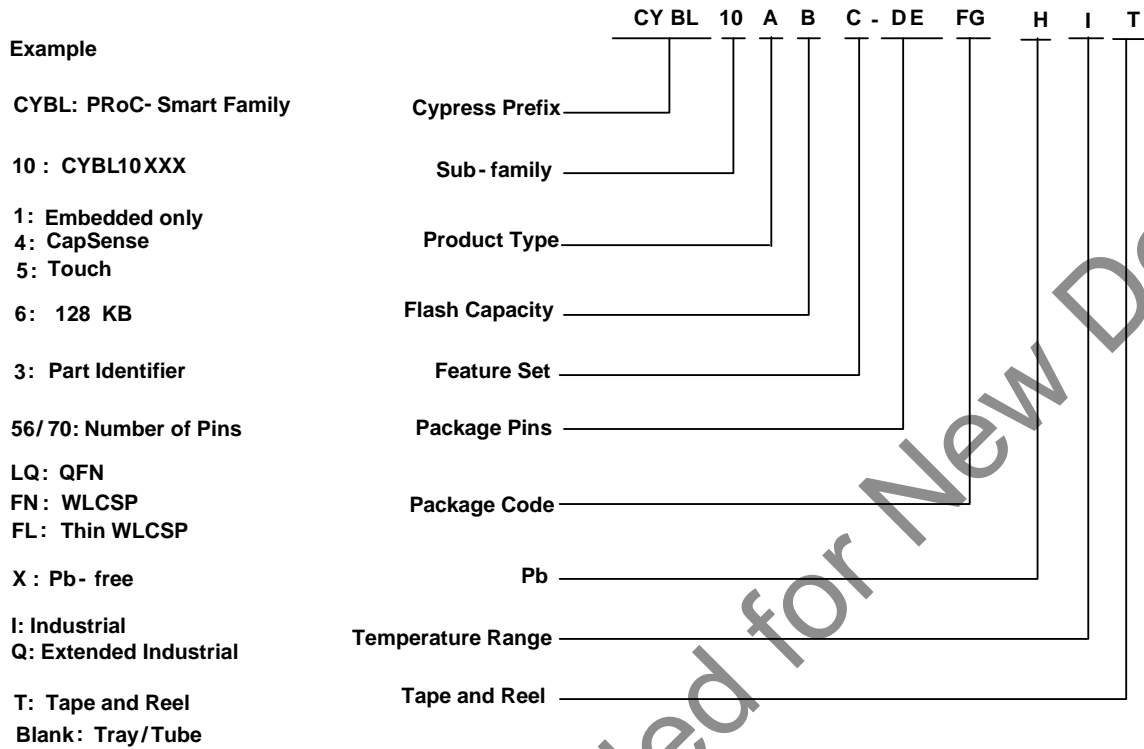

The Field Values are listed in the following table:

Field	Description	Values	Meaning
CYBL	Cypress PRoC BLE Family	CYBL	
10	Subfamily	10	CYBL10X6X
A	Product Type	1	Embedded Only
		4	CapSense
		5	Touch
B	Flash Capacity	6	128 KB
C	Feature set		
DE	Package Pins	56	
		68	
FG	Package code	LQ	QFN
		FN	WLCSP
		FL	Thin WLCSP
H	Pb	X	Pb-free
			X Absent (with Pb)
I	Temperature Range	C	Commercial 0 °C to 70 °C
		I	Industrial -40 °C to 85 °C
		Q	Extended Industrial -40 °C to 105 °C

Packaging

Table 52. Package Characteristics

Parameter	Description	Conditions	Min	Typ	Max	Units
T _A	Operating ambient temperature	Industrial	-40	25	85	°C
		Extended industrial	-40	25	105	°C
T _J	Operating junction temperature	Industrial	-40	-	100	°C
		Extended industrial	-40	-	125	°C
T _{JA}	Package θ_{JA} (56-pin QFN)		-	16.9	-	°C/watt
T _{JC}	Package θ_{JC} (56-pin QFN)		-	9.7	-	°C/watt
T _{JA}	Package θ_{JA} (68-ball WLCSP)		-	16.6	-	°C/watt
T _{JC}	Package θ_{JC} (68-ball WLCSP)		-	0.19	-	°C/watt
T _{JA}	Package θ_{JA} (68-ball Thin WLCSP)		-	16.6	-	°C/watt
T _{JC}	Package θ_{JC} (68-ball Thin WLCSP)		-	0.19	-	°C/watt

Table 53. Solder Reflow Peak Temperature

Package	Maximum Peak Temperature	Maximum Time at Peak Temperature
56-pin QFN	260 °C	30 seconds
68-ball WLCSP	260 °C	30 seconds
68-ball Thin WLCSP	260 °C	30 seconds

Table 54. Package Moisture Sensitivity Level (MSL), IPC/JEDEC J-STD-2

Package	MSL
56-pin QFN	MSL 3
68-ball WLCSP	MSL 1
68-ball Thin WLCSP	MSL 1

Table 55. Package Details

Spec ID	Package	Description
001-58740 Rev. *C	56-pin QFN	7 mm × 7 mm × 0.6 mm
001-92343 Rev. *A	68-ball WLCSP	3.52 mm × 3.91 mm × 0.55 mm
001-99408 Rev **	68-ball Thin WLCSP	3.52 mm X 3.91 mm X 0.4 mm

Figure 5. 56-Pin QFN 7 mm x 7 mm x 0.6 mm

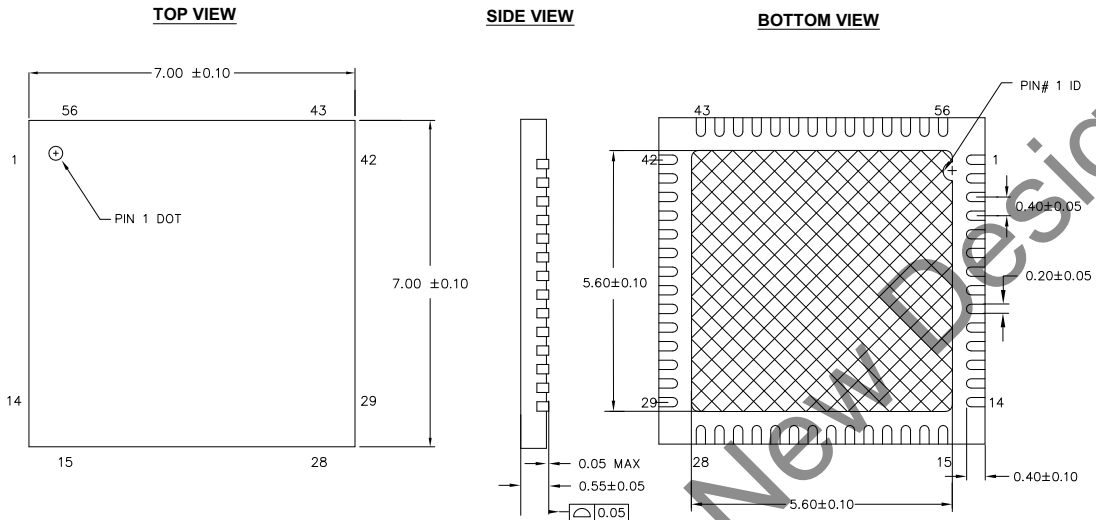

NOTES:

1. HATCH AREA IS SOLDERABLE EXPOSED PAD
2. BASED ON REF JEDEC # MO-248
3. ALL DIMENSIONS ARE IN MILLIMETERS

001-58740 *C

The center pad on the QFN package must be connected to ground (VSS) for the proper operation of the device.

Figure 6. 68-Ball WLCSP Package Outline

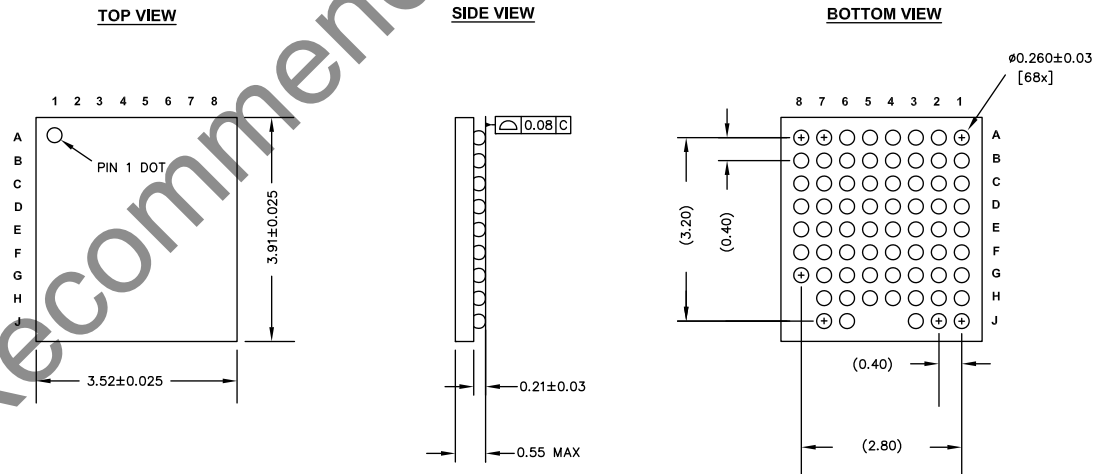

NOTES:

1. REFERENCE JEDEC PUBLICATION 95, DESIGN GUIDE 4.18
2. ALL DIMENSIONS ARE IN MILLIMETERS

001-92343 *A

Figure 7. 68-Ball Thin WLCSP

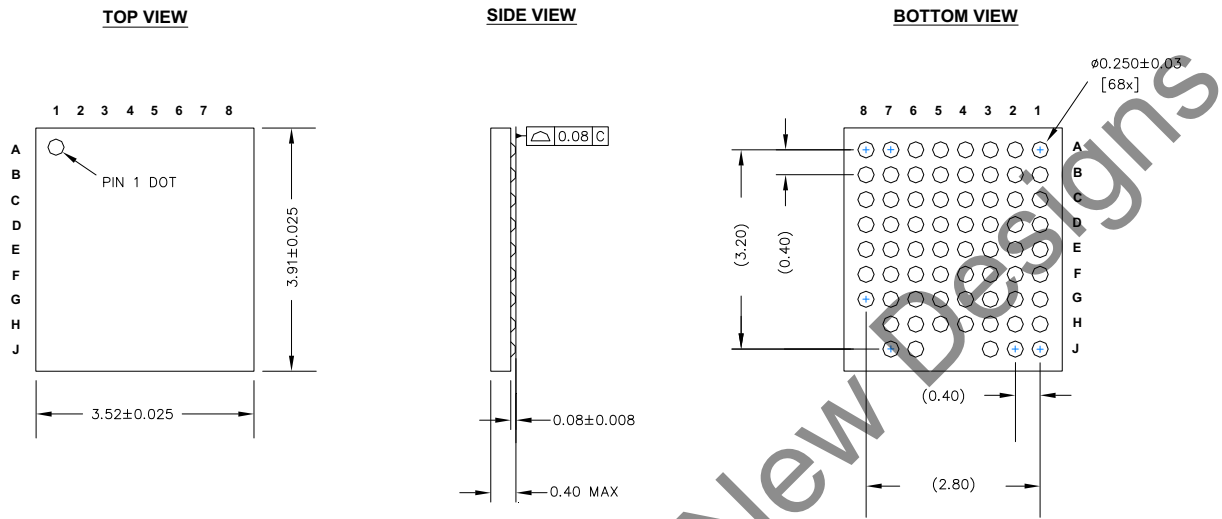

NOTES:

1. REFERENCE JEDEC PUBLICATION 95, DESIGN GUIDE 4.18
2. ALL DIMENSIONS ARE IN MILLIMETERS

001-99408 **

Not Recommended for New Designs

Acronyms

Table 56. Acronyms Used in This Document

Acronym	Description
ABUS	analog local bus
ADC	analog-to-digital converter
AG	analog global
AHB	AMBA (advanced microcontroller bus architecture) high-performance bus, an ARM data transfer bus
ALU	arithmetic logic unit
AMUXBUS	analog multiplexer bus
API	application programming interface
APSR	application program status register
ARM®	advanced RISC machine, a CPU architecture
ATM	automatic thump mode
BW	bandwidth
CAN	Controller Area Network, a communications protocol
CMRR	common-mode rejection ratio
CPU	central processing unit
CRC	cyclic redundancy check, an error-checking protocol
DAC	digital-to-analog converter, see also IDAC, VDAC
DFB	digital filter block
DIO	digital input/output, GPIO with only digital capabilities, no analog. See GPIO.
DMIPS	Dhrystone million instructions per second
DMA	direct memory access, see also TD
DNL	differential nonlinearity, see also INL
DNU	do not use
DR	port write data registers
DSI	digital system interconnect
DWT	data watchpoint and trace
ECC	error correcting code
ECO	external crystal oscillator
EEPROM	electrically erasable programmable read-only memory
EMI	electromagnetic interference
EMIF	external memory interface
EOC	end of conversion
EOF	end of frame
EPSR	execution program status register
ESD	electrostatic discharge

Table 56. Acronyms Used in This Document (continued)

Acronym	Description
ETM	embedded trace macrocell
FET	field-effect transistor
FIR	finite impulse response, see also IIR
FPB	flash patch and breakpoint
FS	full-speed
GPIO	general-purpose input/output, applies to a PSoC pin
HCI	host controller interface
HVI	high-voltage interrupt, see also LVI, LVD
IC	integrated circuit
IDAC	current DAC, see also DAC, VDAC
IDE	integrated development environment
I ² C, or IIC	Inter-Integrated Circuit, a communications protocol
I ² S	Inter-IC Sound
IIR	infinite impulse response, see also FIR
ILO	internal low-speed oscillator, see also IMO
IMO	internal main oscillator, see also ILO
INL	integral nonlinearity, see also DNL
I/O	input/output, see also GPIO, DIO, SIO, USBIO
IPOR	initial power-on reset
IPSR	interrupt program status register
IRQ	interrupt request
ITM	instrumentation trace macrocell
LCD	liquid crystal display
LIN	Local Interconnect Network, a communications protocol.
LR	link register
LUT	lookup table
LVD	low-voltage detect, see also LVI
LVI	low-voltage interrupt, see also HVI
LVTTTL	low-voltage transistor-transistor logic
MAC	multiply-accumulate
MCU	microcontroller unit
MISO	master-in slave-out
NC	no connect
NMI	nonmaskable interrupt
NRZ	non-return-to-zero
NVIC	nested vectored interrupt controller

Table 56. Acronyms Used in This Document (continued)

Acronym	Description
NVL	nonvolatile latch, see also WOL
Opamp	operational amplifier
PAL	programmable array logic, see also PLD
PC	program counter
PCB	printed circuit board
PGA	programmable gain amplifier
PHUB	peripheral hub
PHY	physical layer
PICU	port interrupt control unit
PLA	programmable logic array
PLD	programmable logic device, see also PAL
PLL	phase-locked loop
PMDD	package material declaration data sheet
POR	power-on reset
PRES	precise power-on reset
PRS	pseudo random sequence
PS	port read data register
PSoC [®]	Programmable System-on-Chip [™]
PSRR	power supply rejection ratio
PWM	pulse-width modulator
RAM	random-access memory
RISC	reduced-instruction-set computing
RMS	root-mean-square
RTC	real-time clock
RTL	register transfer language
RTR	remote transmission request
RX	receive
SAR	successive approximation register
SC/CT	switched capacitor/continuous time
SCL	I ² C serial clock
SDA	I ² C serial data
S/H	sample and hold
SINAD	signal to noise and distortion ratio
SIO	special input/output, GPIO with advanced features. See GPIO.
SOC	start of conversion
SOF	start of frame
SPI	Serial Peripheral Interface, a communications protocol
SR	slew rate

Table 56. Acronyms Used in This Document (continued)

Acronym	Description
SRAM	static random access memory
SRES	software reset
STN	super twisted nematic
SWD	serial wire debug, a test protocol
SWV	single-wire viewer
TD	transaction descriptor, see also DMA
THD	total harmonic distortion
TIA	transimpedance amplifier
TN	twisted nematic
TRM	technical reference manual
TTL	transistor-transistor logic
TX	transmit
UART	Universal Asynchronous Transmitter Receiver, a communications protocol
USB	Universal Serial Bus
USBIO	USB input/output, PSoC pins used to connect to a USB port
VDAC	voltage DAC, see also DAC, IDAC
WDT	watchdog timer
WOL	write once latch, see also NVL
WRES	watchdog timer reset
XRES	external reset I/O pin
XTAL	crystal

Document Conventions

Units of Measure

Table 57. Units of Measure

Symbol	Unit of Measure
°C	degrees Celsius
dB	decibel
dBm	decibel-milliwatts
fF	femtofarads
Hz	hertz
KB	1024 bytes
kbps	kilobits per second
Khr	kilohour
kHz	kilohertz
kΩ	kilo ohm
ksps	kilosamples per second
LSB	least significant bit
Mbps	megabits per second
MHz	megahertz
MΩ	mega-ohm
Msp	megasamples per second
μA	microampere
μF	microfarad

Table 57. Units of Measure (continued)

Symbol	Unit of Measure
μH	microhenry
μs	microsecond
μV	microvolt
μW	microwatt
mA	milliampere
ms	millisecond
mV	millivolt
nA	nanoampere
ns	nanosecond
nV	nanovolt
Ω	ohm
pF	picofarad
ppm	parts per million
ps	picosecond
s	second
sps	samples per second
sqrtHz	square root of hertz
V	volt
W	watt

Revision History

Description Title: CYBL10X6X Family Datasheet Programmable Radio-on-Chip With Bluetooth Low Energy (PRoC BLE) Document Number: 001-90478				
Revision	ECN	Orig. of Change	Submission Date	Description of Change
*F	4567076	CSAI	11/11/2014	Initial release
*G	4600081	SKAR	12/19/2014	Revision to 16-bit Timer Counter PWM, block current consumption at 3, 12, and 48 MHz to align with CHAR data Revision of I ² C/ UART block current consumption to align with CHAR data Revision of LCD Direct Drive - operating current in low-power mode to align with CHAR data Revision of BLE RF Average Current Spec for 4-sec BLE connection interval to 6.25 μ A to align with CHAR data Revision of RXS with idle transmitter, with balun loss and in high-gain mode to align with CHAR data Clarified the I _{ECO} operating current to reflect crystal current - LDO and Bandgap current as well Corrected Typo for SID#245 (CPU -> SCB) Corrected Typo for SID#275 Removed errata
*H	4651104	CSAI	02/11/2015	Updated Figure 5 Updated CapSense column for CYBL10563-56LQXI and CYBL10563-68FNXIT parts to "Yes (Gestures)" in Ordering Information table and updated part number Updated Part Numbering Conventions
*I	4779453	HXR	05/28/2015	Removed min and max values for SID359 and SID360. Removed max value and added typ value for SID357.
*J	4810822	GCG	06/29/2015	Updated Figure 1 for clarity Updated Figure 2 and Figure 3 for uniformity Updated Figure 4 with a higher resolution image Removed EZSPI reference. Updated 56-pin QFN package diagram to correct the orientation of text.
*K	4865942	SASD/ SDUR/ UTSV	08/19/2015	Changed temperature range from -40 °C to 85 °C to -40 °C to 105 °C. Added 'overvoltage-tolerant' description to pins P5.0 and P5.1 in CYBL10X6X Pin List (WLCSP Package) . Added clarifying note on overvoltage-tolerant pins for SID76. Updated max values in Timer, Counter, and PWM DC specifications for 105 °C. Added SID257A in Flash AC Specifications . Added Guaranteed by Design note to SID 298. Added SID406A for 105 °C. Added extended industrial temperature range in the Field Values table. Added T _A and T _J for extended industrial in Package Characteristics . Added extended industrial temperature parts in Ordering Information . Added thin WLCSP (CYBL10563-68FLXIT) details in Ordering Information and Packaging sections.
*L	5669710	DEJO	03/23/2017	Updated the template. Added NRND watermark.

Sales, Solutions, and Legal Information

Worldwide Sales and Design Support

Cypress maintains a worldwide network of offices, solution centers, manufacturer's representatives, and distributors. To find the office closest to you, visit us at [Cypress Locations](#).

Products

ARM® Cortex® Microcontrollers	cypress.com/arm
Automotive	cypress.com/automotive
Clocks & Buffers	cypress.com/clocks
Interface	cypress.com/interface
Internet of Things	cypress.com/iot
Memory	cypress.com/memory
Microcontrollers	cypress.com/mcu
PSoC	cypress.com/psoc
Power Management ICs	cypress.com/pmic
Touch Sensing	cypress.com/touch
USB Controllers	cypress.com/usb
Wireless Connectivity	cypress.com/wireless

PSoC® Solutions

[PSoC 1](#) | [PSoC 3](#) | [PSoC 4](#) | [PSoC 5LP](#)

Cypress Developer Community

[Forums](#) | [WICED IOT Forums](#) | [Projects](#) | [Video](#) | [Blogs](#) | [Training](#) | [Components](#)

Technical Support

cypress.com/support



© Cypress Semiconductor Corporation, 2013-2017. This document is the property of Cypress Semiconductor Corporation and its subsidiaries, including Spansion LLC ("Cypress"). This document, including any software or firmware included or referenced in this document ("Software"), is owned by Cypress under the intellectual property laws and treaties of the United States and other countries worldwide. Cypress reserves all rights under such laws and treaties and does not, except as specifically stated in this paragraph, grant any license under its patents, copyrights, trademarks, or other intellectual property rights. If the Software is not accompanied by a license agreement and you do not otherwise have a written agreement with Cypress governing the use of the Software, then Cypress hereby grants you a personal, non-exclusive, nontransferable license (without the right to sublicense) (1) under its copyright rights in the Software (a) for Software provided in source code form, to modify and reproduce the Software solely for use with Cypress hardware products, only internally within your organization, and (b) to distribute the Software in binary code form externally to end users (either directly or indirectly through resellers and distributors), solely for use on Cypress hardware product units, and (2) under those claims of Cypress's patents that are infringed by the Software (as provided by Cypress, unmodified) to make, use, distribute, and import the Software solely for use with Cypress hardware products. Any other use, reproduction, modification, translation, or compilation of the Software is prohibited.

TO THE EXTENT PERMITTED BY APPLICABLE LAW, CYPRESS MAKES NO WARRANTY OF ANY KIND, EXPRESS OR IMPLIED, WITH REGARD TO THIS DOCUMENT OR ANY SOFTWARE OR ACCOMPANYING HARDWARE, INCLUDING, BUT NOT LIMITED TO, THE IMPLIED WARRANTIES OF MERCHANTABILITY AND FITNESS FOR A PARTICULAR PURPOSE. To the extent permitted by applicable law, Cypress reserves the right to make changes to this document without further notice. Cypress does not assume any liability arising out of the application or use of any product or circuit described in this document. Any information provided in this document, including any sample design information or programming code, is provided only for reference purposes. It is the responsibility of the user of this document to properly design, program, and test the functionality and safety of any application made of this information and any resulting product. Cypress products are not designed, intended, or authorized for use as critical components in systems designed or intended for the operation of weapons, weapons systems, nuclear installations, life-support devices or systems, other medical devices or systems (including resuscitation equipment and surgical implants), pollution control or hazardous substances management, or other uses where the failure of the device or system could cause personal injury, death, or property damage ("Unintended Uses"). A critical component is any component of a device or system whose failure to perform can be reasonably expected to cause the failure of the device or system, or to affect its safety or effectiveness. Cypress is not liable, in whole or in part, and you shall and hereby do release Cypress from any claim, damage, or other liability arising from or related to all Unintended Uses of Cypress products. You shall indemnify and hold Cypress harmless from and against all claims, costs, damages, and other liabilities, including claims for personal injury or death, arising from or related to any Unintended Uses of Cypress products.

Cypress, the Cypress logo, Spansion, the Spansion logo, and combinations thereof, WICED, PSoC, CapSense, EZ-USB, F-RAM, and Traveo are trademarks or registered trademarks of Cypress in the United States and other countries. For a more complete list of Cypress trademarks, visit cypress.com. Other names and brands may be claimed as property of their respective owners.

Looking for pricing, stock, or lifecycle information?

Click below to explore more details on WIN SOURCE:

-  [View CYBL10562-56LQXI on WIN SOURCE](#)
-  [Cypress Semiconductor Corp Information](#)

Optimize Your Supply Chain with WIN SOURCE Solutions

-  Global Sourcing Solution
-  Obsolete Management
-  Cost Control Management
-  Shortage Management
-  Alternative Solution
-  Excess Inventory Management