

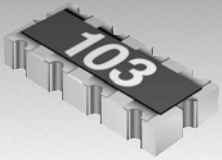

**THE DATASHEET OF
CAT25-222JA**



*RoHS COMPLIANT



BOURNS®

Features

- Concave terminals
- RoHS compliant*
- 8 bit multiple applications
- Smallest bused chip array
- E 24 Series from 10 ohms to 1 megohm

CAT25 - Thick Film Chip Resistor Arrays

Electrical Characteristics

Parameters	CAT25	Test Method
Number of Resistors	8	
Resistance Range E24	10 ohms to 1 megohm	
Resistance Tolerance	5 %	JIS-C-5202.5.1
Power Rating/Resistor	62.5 mW	
Rating Temperature	+70 °C	
T.C.R.	±200 ppm/°C	JIS-C-5202.5.2
Maximum Operating Voltage	25 V	
Operating Temperature	-55 °C to +125 °C	

Environmental Characteristics

Specification	Characteristics	Test Method
Short Time Overload	±(3 % +0.1 ohm)	JIS-C-5202.5.5
Load Life	±(5 % +0.1 ohm)	JIS-C-5202.7.10
Humidity Load Life	±(3 % +0.1 ohm)	JIS-C-5202.7.9
Resistance to Soldering Heat	±(1 % +0.1 ohm)	JIS-C-5202.6.4
Terminal Strength	±(1 % +0.1 ohm)	JIS-C-5202.6.
Temperature Cycle	±(2 % +0.1 ohm)	JIS-C-5202.7.4
Vibration	±(1 % +0.1 ohm)	JIS-C-5202.6.3
Insulation Resistance	1000 megohms minimum	JIS-C-5202.5.6
Dielectric Withstanding Voltage	50 VRMS	JIS-C-5202.5.7
Lead Solderability	>95 %	JIS-C-5202.6.5

How To Order

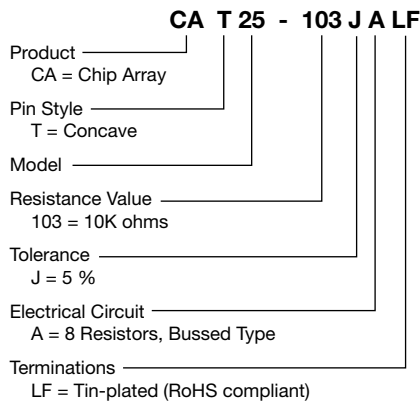

For Standard Values Used in Capacitors, Inductors, and Resistors, [click here](#).

Outline Drawing

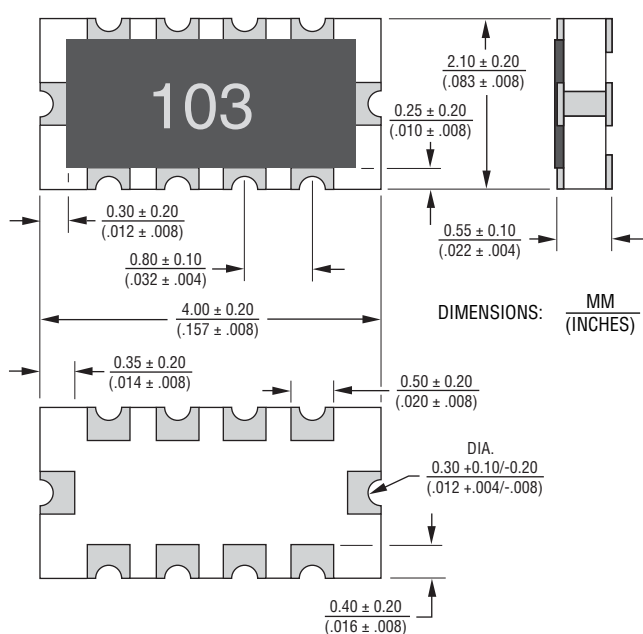

Land Pattern

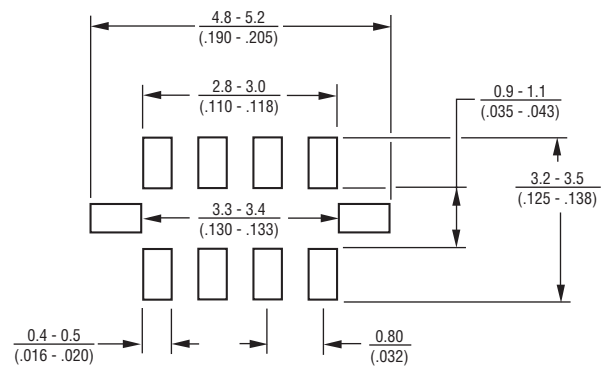

Electrical Circuit

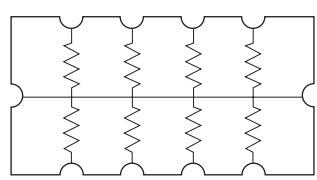

*RoHS Directive 2002/95/EC Jan 27, 2003 including Annex. Specifications are subject to change without notice. Customers should verify actual device performance in their specific applications

CAT25 - Thick Film Chip Resistor Arrays

BOURNS®

Soldering Profile for RoHS Compliant Chip Resistors and Arrays

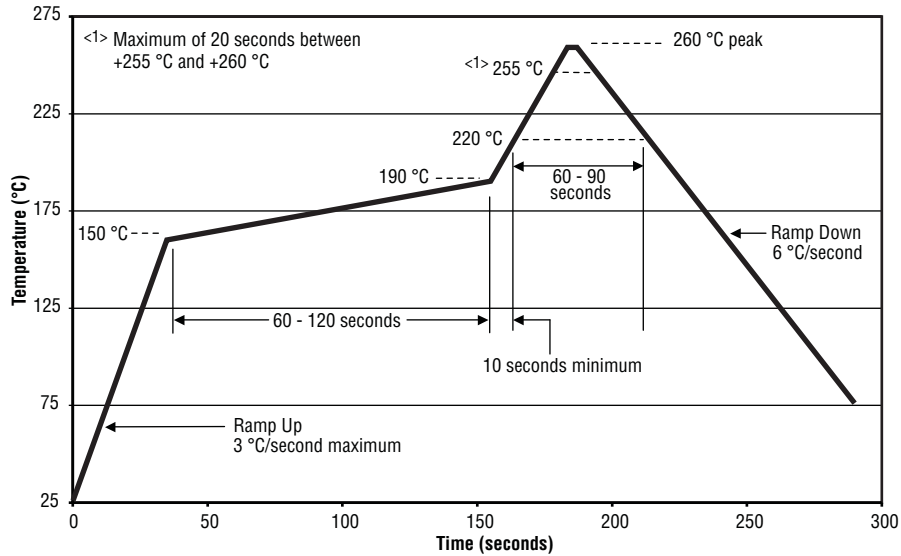

Packaging



12
(.472) embossed tape
4,000 pcs. per reel

Material

Substrate	Alumina 96
Element	Ruthenium Oxide
Coating	Glass
Terminal	Plated Ni+Sn

Looking for pricing, stock, or lifecycle information?

Click below to explore more details on WIN SOURCE:

-  [View CAT25-222JA on WIN SOURCE](#)
-  [Bourns Inc. Information](#)

Optimize Your Supply Chain with WIN SOURCE Solutions

-  Global Sourcing Solution
-  Obsolete Management
-  Cost Control Management
-  Shortage Management
-  Alternative Solution
-  Excess Inventory Management