

REFERENCE DESIGN

IRDCiP1001-A

International Rectifier • 233 Kansas Street, El Segundo, CA 90245 USA

IRDCiP1001-A, 200kHz, 20A, 3.3V_{IN} to 4.5V_{IN} Single Phase Synchronous Buck Converter using iP1001

Overview

In this document, Table 1 and Figure 1 are provided to enable engineers to easily evaluate the iP1001 in a single phase configuration that is capable of providing up to 20A in a lab environment without airflow. Figures 3, 4, 5 and 6 and the complete bill of materials in Table 2 are provided as a reference design to enable engineers to very quickly and easily design a single phase converter. In order to optimize this design to your specific requirements, refer to the iP1001 data sheet for guidelines on external component selection and user adjustable limits and specifications. Custom designs may require layout modifications.

iPOWIR™
 TECHNOLOGY

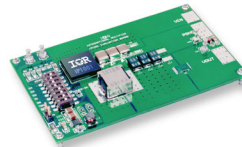

	Min	Max
V _{IN}	3.3V	4.5V
V _{OUT}	0.925V	2.5V
I _{OUT}	See Fig.1	

Demoboard Quick Start Guide

Initial Settings:

- The output is set to 2V, but can be adjusted from 0.925V to 2.0V by setting SW1 according to the VID codes provided in Table 1. The output voltage can also be adjusted to allow up to 2.5V_{OUT} for 3.3V_{IN}, by adding R3 & R4 with the DAC set to 2V_{OUT}. Refer to equation 1 for R3 & R4 values. R4 should be removed for output voltages below 2V, and R3 should be set to zero ohms (see Table 2).
- The switching frequency is centered around 200kHz for <5V_{IN} applications with the FREQ pin connected to V_{DD}.
- The input voltage range can be increased to allow operation between 5V_{IN} and 12V_{IN}. Refer to IRDCiP1001-B reference design documentation for direction on changing the configuration of the demo board.

Procedure for Connecting and Powering Up Demoboard:

1. Apply input voltage (3.3V-4.5V) across V_{IN} and PGND. Note that this demo board has a mini-boost circuit provided in order to provide the 5V_{DD} internal logic for the iP1001. This boost circuit can be used to provide power for up to 5 x iP1001 devices simultaneously.
2. Apply load across VOUT pad and PGND pad.
3. Make sure Jumpers JP2 and JP3 are connected.
4. Remove jumper JP1 to turn on the boost circuit and pull iP1001 ENABLE pin high. The ENABLE pin is controlled via switch 8 on SW1. This pin is supplied in low state, once pulled high the output is enabled.
5. Adjust load accordingly.

IRDCiP1001-A Recommended Operating Conditions

(refer to the iP1001 datasheet for maximum operating conditions)

Input voltage: 3.3 - 4.5V (V_{DD} provided by mini boost circuit)
 Output voltage: DAC selectable between 0.925V - 2.0V (with extended operating range to 3.3V with R3 & R4)
 Output current: Up to 20A depending on duty factor (refer to recommended operating area Fig.1).
 Switching Freq: 200kHz or 300kHz selectable.

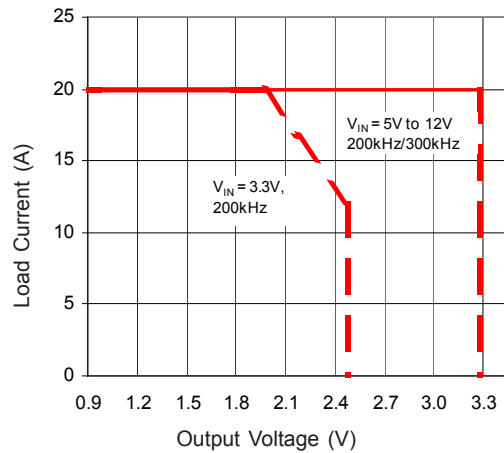

Fig. 1 - Recommended Operating Area

D4	D3	D2	D1	D0	Output Voltage (V)	D4	D3	D2	D1	D0	Output Voltage (V)
0	0	0	0	0	2.00	1	0	0	0	0	1.275
0	0	0	0	1	1.95	1	0	0	0	1	1.250
0	0	0	1	0	1.90	1	0	0	1	0	1.225
0	0	0	1	1	1.85	1	0	0	1	1	1.200
0	0	1	0	0	1.80	1	0	1	0	0	1.175
0	0	1	0	1	1.75	1	0	1	0	1	1.150
0	0	1	1	0	1.70	1	0	1	1	0	1.125
0	0	1	1	1	1.65	1	0	1	1	1	1.100
0	1	0	0	0	1.60	1	1	0	0	0	1.075
0	1	0	0	1	1.55	1	1	0	0	1	1.050
0	1	0	1	0	1.50	1	1	0	1	0	1.025
0	1	0	1	1	1.45	1	1	0	1	1	1.000
0	1	1	0	0	1.40	1	1	1	0	0	0.975
0	1	1	0	1	1.35	1	1	1	0	1	0.950
0	1	1	1	0	1.30	1	1	1	1	0	0.925
0	1	1	1	1	Shutdown*	1	1	1	1	1	Shutdown*

* Shutdown : Upon receipt of the shutdown code (per VID code table above), both FETs are turned OFF and the output is discharged as it enters UVP fault mode.

Table 1 - iP1001 VID Code

For output voltages above the DAC maximum setting of 2V, refer to Equation 1 below to calculate the required resistor values for R3 & R4 (needed in order to achieve the extended output voltage range).

$$\text{Equation 1: } V_{out} = V_F \cdot \{1 + R3/R4\}$$

where V_F is equal to the DAC setting

and R4 is recommended to be $\sim 1k\Omega$

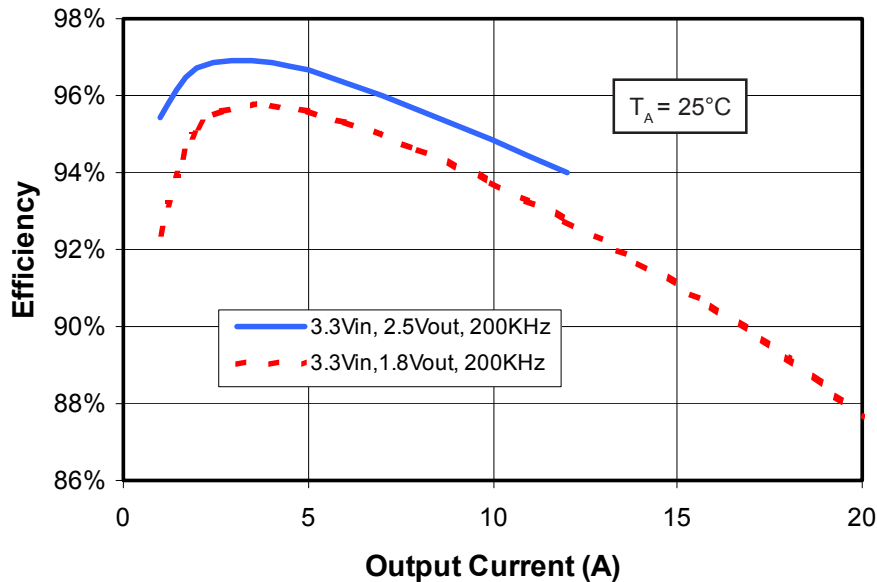

Fig. 2 - Typical Efficiency vs. Current

Refer to the following application notes for detailed guidelines and suggestions when implementing iPOWIR Technology products:

AN-1028: Recommended Design, Integration and Rework Guidelines for International Rectifier's iPOWIR Technology BGA Packages

This paper discusses the assembly considerations that need to be taken when mounting iPOWIR BGA's on printed circuit boards. This includes soldering, pick and place, reflow, inspection, cleaning and reworking recommendations.

AN-1029: Optimizing a PCB Layout for an iPOWIR Technology Design

This paper describes how to optimize the PCB layout design for both thermal and electrical performance. This includes placement, routing, and via interconnect suggestions.

AN-1030: Applying iPOWIR Products in Your Thermal Environment

This paper explains how to use the Power Loss and SOA curves in the data sheet to validate if the operating conditions and thermal environment are within the Safe Operating Area of the iPOWIR product.

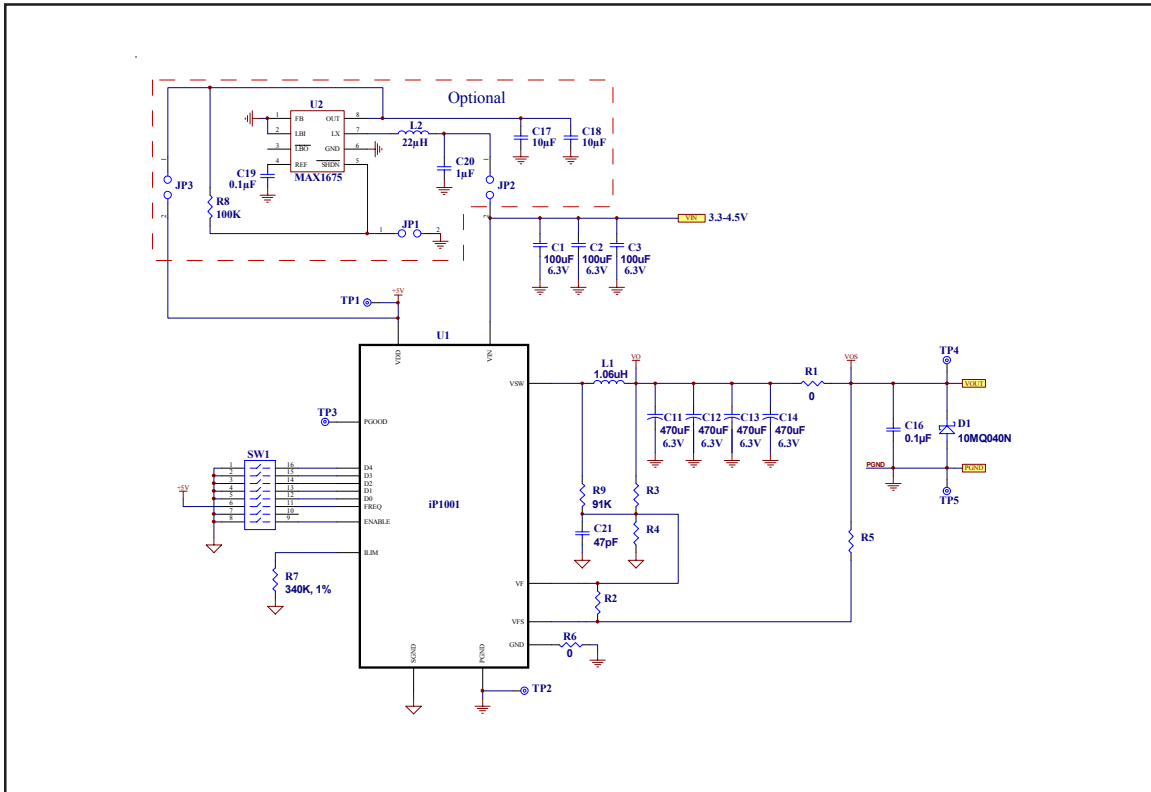

Fig. 3 - Reference Design Schematic

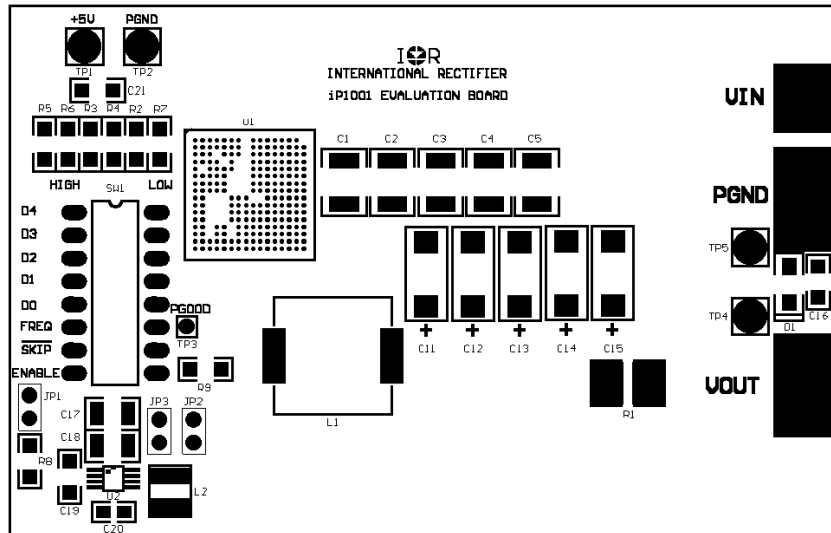

Fig. 4 - Component Placement (Top View)

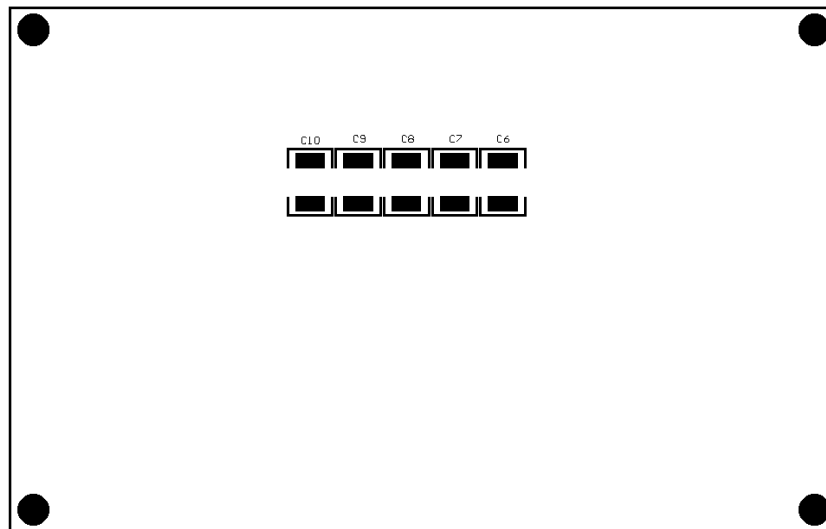

Fig. 5 - Component Placement (Bottom View)

IRDCiP1001-A

IRDCiP1001-A (For operation <4.5V_{IN})

Designator	Value	Part Type	Footprint	Mfr.	Mfr. P/N
C1, C3, C5	100uF	Capacitor, 6.3V, 20%, X5R	1812	TDK	C4532X5R0J107MT
C2, C4, C6, C7, C8, C9, C10, C15	-	Not Installed	-	-	-
C11, C12, C13, C14	470uF	Capacitor, 6.3V, 20%, Tantalum	7343	Sanyo	6TPB470M
C16, C19	0.100uF	Capacitor, 50V, 10%, X7R	1206	Novacap	1206B104K500N
C17, C18	10.0uF	Capacitor, 16V, 10%, X5R	1210	TDK	C3225X5R1C106KT
C20	1.00uF	Capacitor, 10V, 10%, X7R	0805	MuRata	GRM40X7R105K010
C21	47.0pF	Capacitor, 50V, 5%, C0G	1206	MuRata	GRM42-6C0G470J050A
D1	40V	Schottky Diode, 40V, 2.1A	D-64	International Rectifier	10MQ040N
JP1, JP2, JP3	-	Test Point	-	Samtec	TSW-102-07-LS
JP1-1, JP2-1, JP3-1	-	Shunt	-	Samtec	SNT-100-BKT
L1	1.06uH	Inductor, 16A, 20%, Ferrite	SMT	Panasonic	ETQP6F1R1BFA
L2	22uH	Inductor, 0.68A, 20%, Ferrite	SMT	Sumida	CR43-220
R1	0Ω	Resistor, 0Ω Jumper	2716	Isotek Corp	SMT-R000
R2	-	For <2V _{out} , Not installed For >2V _{out} , Resistor, 0Ω Jumper	SMT	-	-
R3	-	For <2V _{out} , Resistor, 0Ω Jumper For >2V _{out} see formula for value	SMT	-	-
R4	-	For <2V _{out} , Not installed For >2V _{out} recommend 1kΩ see formula for detail	SMT	-	-
R5	-	For <2V _{out} , Resistor, 0Ω Jumper For >2V _{out} , Not installed	1206	Panasonic	ERJ-8GEY0R00
R6	0Ω	Resistor, 0Ω Jumper	1206	-	-
R7	340kΩ	Resistor, 340kΩ, 1% 340kΩ sets for 20A limit. See ILIM formula for other values	1206	ROHM	MCR18EZH3403
R8	100kΩ	Resistor, 100kΩ, 5%	1206	ROHM	MCR18EZHJ104
R9	91kΩ	Resistor, 91kΩ, 5%	1206	ROHM	MCR18EZHJ913
SW1	-	8-position DIP switch	SMT	C&K Components	SD08H0SK
TP1, TP3	-	Not Installed	-	-	-
TP2, TP4, TP5	-	Test Point	-	Keystone	1502-2
U1	-	Power Block	SSBGA 14mmx14mm	International Rectifier	iP1001
U2	-	IC, Step-Up DC-DC Converter, 0.5A	8uMAX	Maxim	MAX1675EUA

Table 2 - Reference Design Bill of Materials

Adjusting the Current Limit

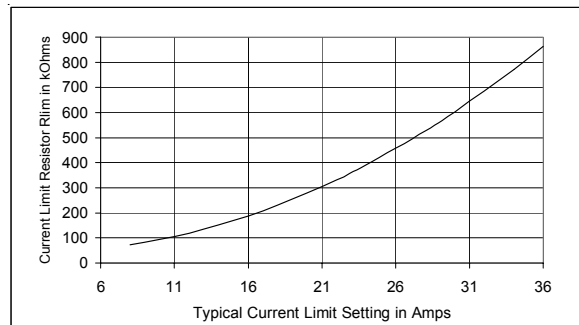

Fig. 6 Current Limit Adjustment using R_{LIM}

Use of this design for any application should be fully verified by the customer. International Rectifier cannot guarantee suitability for your applications, and is not liable for any result of usage for such applications including, without limitation, personal or property damage or violation of third party intellectual property rights.

IR WORLD HEADQUARTERS: 233 Kansas St., El Segundo, California 90245, USA Tel: ++ 1 310 252 7105
Technical Assistance Center (TAC) Fax : ++ 1 310 252 7903

www.irf.com

Looking for pricing, stock, or lifecycle information?

Click below to explore more details on WIN SOURCE:

-  [View IRDCIP1001-A on WIN SOURCE](#)
-  [Infineon Technologies](#) Information

Optimize Your Supply Chain with WIN SOURCE Solutions

-  Global Sourcing Solution
-  Obsolete Management
-  Cost Control Management
-  Shortage Management
-  Alternative Solution
-  Excess Inventory Management