

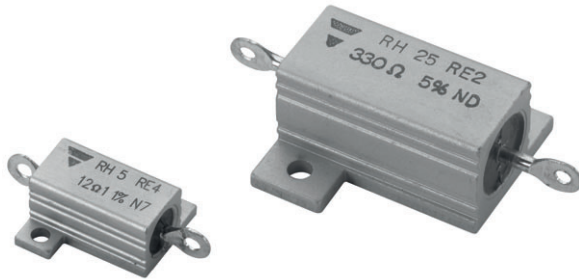

**THE DATASHEET OF
RH2552R30FS03**



Heatsink Encased Wirewound Power Resistors



FEATURES

- 5 W to 50 W at 25 °C
- NF C 83-210
- According to CECC 40 203
- High stability < 0.05 % year
- Low temperature coefficient typically ± 15 ppm/°C
- Wide range of values from 0.006 Ω to 130 k Ω
- Termination = Sn/Ag/Cu
- Material categorization: for definitions of compliance please see www.vishay.com/doc?99912

RoHS
COMPLIANT

Encased in a compact and light heatsink offering complete environmental protection, great mechanical strength and easy mounting. Non inductive versions can be supplied under the RHNI designation (please indicate required specifications and frequency range upon ordering).

NF F 16101, 10/1988 and 16102, 04/1992: Not applicable (our parts contain less than 10 g of combustible materials).

DIMENSIONS in millimeters

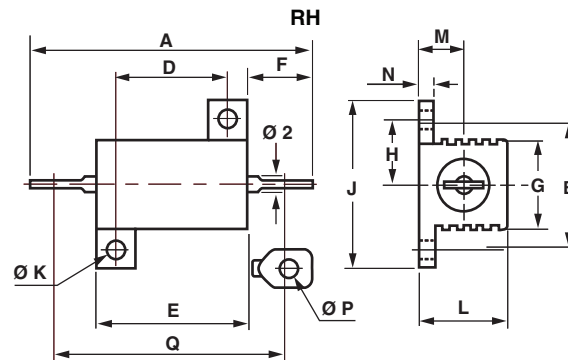

SERIES	A	B ± 0.2	D ± 0.2	E ± 0.5	F	G ± 1	H ± 0.7	J ± 0.5	Ø K ± 0.1	L MAX.	M ± 0.5	N ± 0.3	Ø P MIN.	Q	WEIGHT g
RH5	28.5 ± 1.5	12.5	11.3	16.3	6.8 ± 1.5	8.5	6.2	16.4	2.4	8.9	4.3	1.6	2.1	25.3 ± 1.5	4
RH10	35.5 ± 1.5	15.9	14	19	7.9 ± 1.5	11	7.9	20.6	2.4	11	5.6	2	2.1	30.6 ± 1.5	6.4
RH25	49 ± 1.3	19.8	18.3	28	11.1 ± 1.5	14	9.9	27.5	3.2	15	8	2.4	2.1	44.6 ± 1.3	16.1
RH50	70.2 ± 1.4	21.4	39.7	50	11 ± 1.2	14	10.7	29.4	3.2	15	8	2.4	2.1	66.5 ± 1.4	28.6

OHMIC RANGE IN RELATION TO TOLERANCE

		RH5	RH10	RH25	RH50
10 %	E24	0.01 Ω to 12 k Ω	0.006 Ω to 20 k Ω	0.006 Ω to 62 k Ω	0.006 Ω to 130 k Ω
5 %	E24	0.01 Ω to 12 k Ω	0.01 Ω to 20 k Ω	0.01 Ω to 62 k Ω	0.01 Ω to 130 k Ω
2 %	E48	0.01 Ω to 12 k Ω	0.01 Ω to 20 k Ω	0.01 Ω to 62 k Ω	0.01 Ω to 130 k Ω
1 %	E96	0.1 Ω to 12 k Ω	0.1 Ω to 20 k Ω	0.05 Ω to 62 k Ω	0.05 Ω to 130 k Ω
0.5 %	E96	0.1 Ω to 12 k Ω	0.1 Ω to 20 k Ω	0.1 Ω to 62 k Ω	0.1 Ω to 130 k Ω



STANDARD ELECTRICAL SPECIFICATIONS					
MODEL	RATED POWER $P_{25\text{ }^\circ\text{C}}$ W	VOLTAGE LIMIT V_{RMS}	TOLERANCE $\pm \%$	RESISTANCE RANGE Ω	TEMPERATURE COEFFICIENT $\pm \text{ppm}/^\circ\text{C}$
RH5	10	160	2, 5, 10	0.01 to 12K	< 5 $\Omega \pm 100$, 5 Ω to 10 $\Omega \pm 50$, > 10 $\Omega \pm 25$
	10		0.5, 1	0.1 to 12K	
RH10	12.5	250	10	0.006 to 20K	
	12.5		2, 5	0.01 to 20K	
	12.5		0.5, 1	0.1 to 20K	
RH25	25	550	10	0.006 to 62K	
	25		2, 5	0.01 to 62K	
	25		1	0.05 to 62K	
	25		0.5	0.1 to 62K	
RH50	50	1285	10	0.006 to 130K	
	50		2, 5	0.01 to 130K	
	50		1	0.05 to 130K	
	50		0.5	0.1 to 130K	

TECHNICAL SPECIFICATIONS						
VISHAY SFERNICE MODEL AND STYLE			RH5	RH10	RH25	RH50
Power Rating Chassis Mounted Resistors	MIL Limits	25 °C	5 W	10 W	20 W	30 W
		70 °C	4 W	8 W	16 W	24 W
413 cm ² for RH5 and RH10 536 cm ² for RH25 and RH50	Vishay Sfernice Limits	25 °C	10 W	12.5 W	25 W	50 W
		70 °C	8 W	10 W	20 W	40 W
Unmounted Resistors	Vishay Sfernice Limits	25 °C	4 W	6 W	9 W	12 W
		70 °C	3.2 W	4.8 W	7.2 W	9.6 W
Rated Maximum Voltage (V_{RMS})			160 V	250 V	550 V	1285 V
Dielectric Strength V_{RMS}			1000 V	1500 V	2500 V	2500 V

PERFORMANCE				
TESTS	MIL-R-18546 D	NF C 83-210		TYPICAL DRIFTS
	CONDITIONS	REQUIREMENTS		
Operating Temperature Range	-55 °C +200 °C	-	-	-
Momentary Overload	5 P_r /5 s	$\pm (0.25 \% + 0.05 \Omega)$		$\pm (0.1 \% + 0.05 \Omega)$
Climatic Sequence	-55 °C +200 °C 5 cycles	$\pm (0.25 \% + 0.05 \Omega)$		$\pm (0.1 \% + 0.05 \Omega)$
Load Life Test at High Temperature	2 h at +275 °C	$\pm (1 \% + 0.05 \Omega)$ Ins. resistance $\geq 1 \text{ G}\Omega$		$\pm (0.1 \% + 0.05 \Omega)$
Humidity (Steady State)	56 days	$\pm (1 \% + 0.05)$ Ins. resistance $\geq 100 \text{ M}\Omega$		$\pm (0.5 \% + 0.05 \Omega)$
Resistance to Moisture	Climatic sequences test, with load and polarisation	$\pm (1 \% + 0.05 \Omega)$		$\pm (0.5 \% + 0.05 \Omega)$
Temperature Coefficient	5 Ω to 10 Ω > 10 Ω	$\pm 50 \text{ ppm}/^\circ\text{C}$ $\pm 25 \text{ ppm}/^\circ\text{C}$		$\pm 15 \text{ ppm}/^\circ\text{C}$
Load Life at Maximum Temperature	1000 h 25 °C	P_n MIL Vishay	$\pm (1 \% + 0.05 \Omega)$	$\pm (0.1 \% + 0.05 \Omega)$
	200 °C	30 % of P_n Sfernice	Ins. resistance $\geq 1 \text{ G}\Omega$	$\pm (0.5 \% + 0.05 \Omega)$



MOMENTARY OVERLOAD

1. Momentary overload (> 2 s):

See example in table below. In all cases, it should be understood that:

- The 12 P_n overload applies only to ohmic values 0.1.
- The overload voltage shall not be higher than that used for the dielectric strength test (see Standard Electrical Specifications).

2. Short time overload (< 2 s):

For times shorter than 2 s, higher overloads can be sustained in some cases. Consult Vishay Sfernice.

POWER LOADING	DURATION
2.5 P_n	10 s
5 P_n	5 s
12 P_n	2 s

POWER RATING

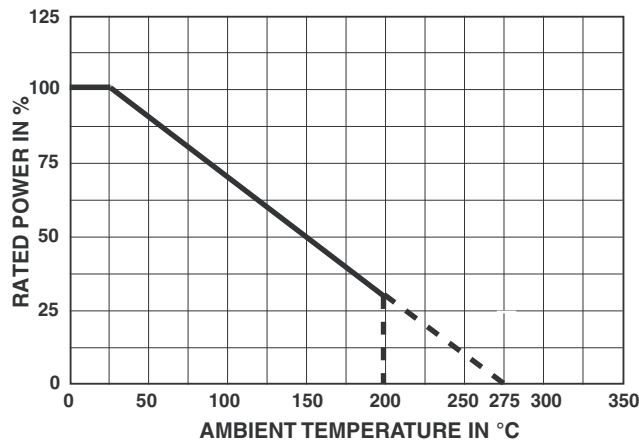

TEMPERATURE RISE

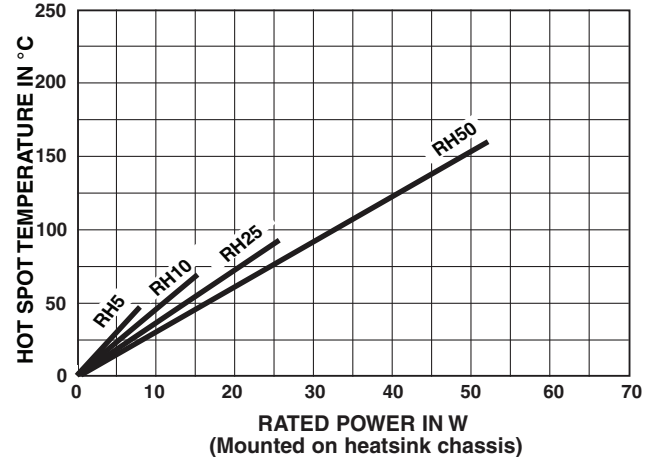

MARKING

Vishay Sfernice trademark, model, style, nominal resistance (in Ω), tolerance (in %), manufacturing date.

PACKAGING

Bag of 10 units

ORDERING INFORMATION

RH	05	N	18R00	J	S03
MODEL	STYLE	NON INDUCTIVE WINDING Optional	OHMIC VALUE	TOLERANCE	PACKAGING

GLOBAL PART NUMBER INFORMATION

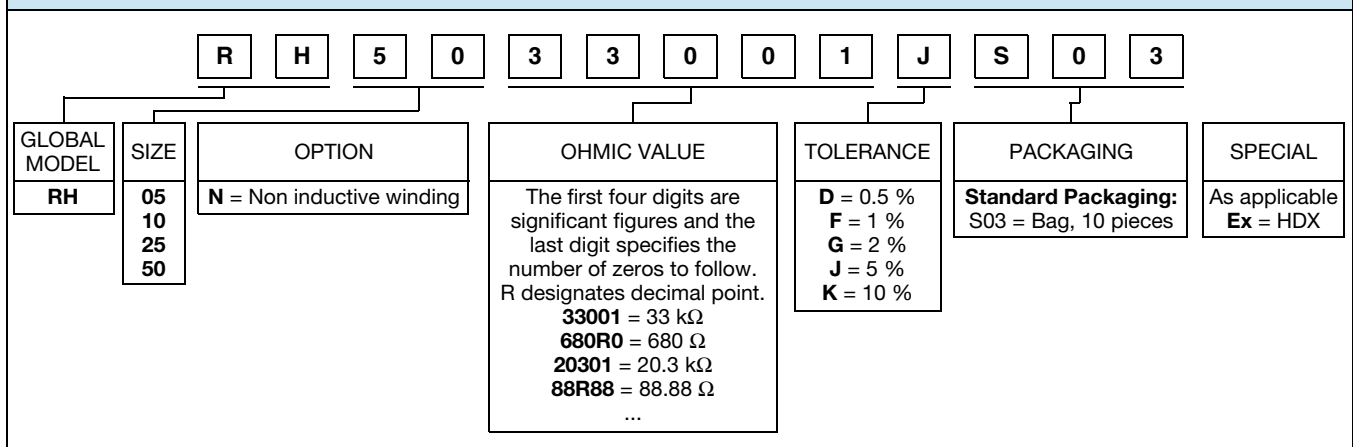



RELATED DOCUMENTS	
APPLICATION NOTES	
Potentiometers and Trimmers	www.vishay.com/doc?51001
Guidelines for Vishay Sfernice Resistive and Inductive Components	www.vishay.com/doc?52029



Disclaimer

ALL PRODUCT, PRODUCT SPECIFICATIONS AND DATA ARE SUBJECT TO CHANGE WITHOUT NOTICE TO IMPROVE RELIABILITY, FUNCTION OR DESIGN OR OTHERWISE.

Vishay Intertechnology, Inc., its affiliates, agents, and employees, and all persons acting on its or their behalf (collectively, "Vishay"), disclaim any and all liability for any errors, inaccuracies or incompleteness contained in any datasheet or in any other disclosure relating to any product.

Vishay makes no warranty, representation or guarantee regarding the suitability of the products for any particular purpose or the continuing production of any product. To the maximum extent permitted by applicable law, Vishay disclaims (i) any and all liability arising out of the application or use of any product, (ii) any and all liability, including without limitation special, consequential or incidental damages, and (iii) any and all implied warranties, including warranties of fitness for particular purpose, non-infringement and merchantability.

Statements regarding the suitability of products for certain types of applications are based on Vishay's knowledge of typical requirements that are often placed on Vishay products in generic applications. Such statements are not binding statements about the suitability of products for a particular application. It is the customer's responsibility to validate that a particular product with the properties described in the product specification is suitable for use in a particular application. Parameters provided in datasheets and / or specifications may vary in different applications and performance may vary over time. All operating parameters, including typical parameters, must be validated for each customer application by the customer's technical experts. Product specifications do not expand or otherwise modify Vishay's terms and conditions of purchase, including but not limited to the warranty expressed therein.

Hyperlinks included in this datasheet may direct users to third-party websites. These links are provided as a convenience and for informational purposes only. Inclusion of these hyperlinks does not constitute an endorsement or an approval by Vishay of any of the products, services or opinions of the corporation, organization or individual associated with the third-party website. Vishay disclaims any and all liability and bears no responsibility for the accuracy, legality or content of the third-party website or for that of subsequent links.

Vishay products are not designed for use in life-saving or life-sustaining applications or any application in which the failure of the Vishay product could result in personal injury or death unless specifically qualified in writing by Vishay. Customers using or selling Vishay products not expressly indicated for use in such applications do so at their own risk. Please contact authorized Vishay personnel to obtain written terms and conditions regarding products designed for such applications.

No license, express or implied, by estoppel or otherwise, to any intellectual property rights is granted by this document or by any conduct of Vishay. Product names and markings noted herein may be trademarks of their respective owners.

Looking for pricing, stock, or lifecycle information?

Click below to explore more details on WIN SOURCE:

 [View RH2552R30FS03 on WIN SOURCE](#)

 [Vishay Information](#)

Optimize Your Supply Chain with WIN SOURCE Solutions

-  Global Sourcing Solution
-  Obsolete Management
-  Cost Control Management
-  Shortage Management
-  Alternative Solution
-  Excess Inventory Management