



**THE DATASHEET OF
EVALM5E1B1245NSICTOBO1**



CoolSiC™ MOSFET motor drives evaluation board for 7.5 kW

Eval-M5-E1B1245N-SiC

About this document

Scope and purpose

This application note provides an overview of the evaluation board Eval-M5-E1B1245N-SiC including its main features, key data, pin assignments and mechanical dimensions.

Eval-M5-E1B1245N-SiC is a complete evaluation board including a 3-phase SiC power module for motor drive applications. In combination with control boards equipped with the M5 32-pin interface connector such as the XMC DriveCard 4400, it features and demonstrates Infineon's CoolSiC™ MOSFETs in motor drives.

The evaluation board Eval-M5-E1B1245N-SiC was developed to support customers during their first steps designing applications with the sixpack power module FS45MR12W1M1_B11. The module has a rated blocking voltage of 1200 V at a typical on-state resistance of 45 mOhm. It is optimized for motor drive applications with a very high-frequency switching operation.

Intended audience

This application note is intended for power electronic engineers evaluating the use of CoolSiC™ devices in drives applications.

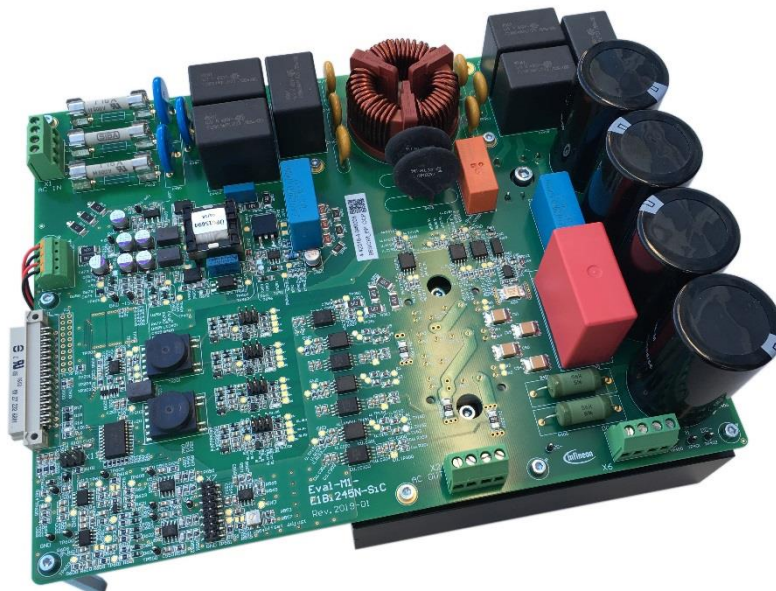









Table of Contents

About this document	1
Table of Contents	2
1 Safety Precautions	3
2 Introduction	4
3 Design Features	5
3.1 Functional Groups.....	7
3.2 Pin Assignment.....	9
3.3 Analogue Measurement Adjustment	12
4 Schematics and Layout	13
4.1 Overview	13
4.2 Input Circuit.....	13
4.3 EMI Filter	14
4.4 Auxiliary Supply	15
4.5 Power Stage.....	16
4.6 Driver Circuit.....	17
4.7 Thermistor Output	19
4.8 Current Measurement	20
4.9 Voltage Measurement	20
4.10 Digital to Analogue Converter.....	22
4.11 Overcurrent / Short Circuit Protection	23
4.12 PCB Layout	24
5 Bill of Material	26
6 Measurements	33
6.1 Thermal measurements.....	34
6.2 EMI measurements.....	35
7 References	37
Revision History	38

1 Safety precautions

Table 1 Precautions

	<p><i>Caution: The DC link potential of the Eval-M5-E1B1245N-SiC system is connected to the grid input. When measuring voltage waveforms by oscilloscope, high-voltage differential probes must be used. Failure to do so may result in personal injury or death. Darkened display LEDs are not an indication that capacitors have discharged to safe voltage levels.</i></p>
	<p><i>Caution: The Eval-M5-E1B1245N-SiC system contains DC bus capacitors which take time to discharge after removal of the main supply. Before working on the drive system, wait five minutes for capacitors to discharge to safe voltage levels. Failure to do so may result in personal injury or death. Darkened display LEDs are not an indication that capacitors have discharged to safe voltage levels.</i></p>
	<p><i>Caution: Only personnel familiar with the drive and ancillary machinery should plan or perform installation, start-up and subsequent maintenance of the system. Failure to comply may result in personal injury and/or equipment damage.</i></p>
	<p><i>Caution: The surfaces of the drive may become hot, which may cause injury.</i></p>
	<p><i>Caution: The Eval-M5-E1B1245N-SiC system contains parts and subassemblies sensitive to electrostatic discharge (ESD). Electrostatic control precautions are required when installing, testing, servicing or repairing the assembly. Component damage may result if ESD control procedures are not observed. If you are not familiar with electrostatic control procedures, refer to applicable ESD protection handbooks and guidelines.</i></p>
	<p><i>Caution: A drive, incorrectly applied or installed, can result in component damage or in the reduction of product lifetime. Wiring or application errors such as undersized motors, provision of incorrect or insufficient AC supply, or excessive ambient temperature may result in system malfunction.</i></p>
	<p><i>Caution: Remove or disconnect power from the drive before you disconnect or reconnect wires or perform service. Wait five minutes after removing power to discharge the bus capacitors. Do not attempt to service the drive until the bus capacitors have discharged to zero. Failure to do so may result in personal injury or death.</i></p>
	<p><i>Caution: The Eval-M5-E1B1245N-SiC system is shipped with packing materials that need to be removed prior to installation. Failure to remove all packing materials which are unnecessary for system installation may result in overheating or abnormal operating conditions.</i></p>

2 Introduction

The Eval-M5-E1B1245N-SiC evaluation board is part of the iMOTION™ Modular Application Design Kit for motor drives (iMOTION™ MADK).

The MADK platform is intended for use at various power stages with different control boards. These boards can easily be interfaced via the iMOTION™ MADK-M5 32-pin interface connector to control boards such as the XMC DriveCard 4400 or XMC DriveCard 1300.

This evaluation board is designed as an easy-to-use power stage based on Infineon's 3-phase power modules. The board is equipped with shunts in the phase output enabling the implementation of sensorless control. It provides a three-phase AC connector, EMI filter, rectifier and a 3-phase output for connecting the motor. The power stage also contains isolated current, voltage and temperature sensing circuits.

The Eval-M5-E1B1245N-SiC evaluation board is available via regular Infineon distribution partners as well as on Infineon's website. The features of this board are described in the design feature chapter of this document. The remaining paragraphs provide information enabling customers to copy, modify and qualify the design for production according to their own specific requirements.

Environmental conditions were considered in the design of the Eval-M5-E1B1245N-SiC. The design was tested as described in this document, but not qualified in terms of safety requirements, manufacturing and operation over the entire operating temperature range or lifetime. The boards provided by Infineon are subject to functional testing only.

Evaluation boards are not subject to the same procedures as regular products regarding Returned Material Analysis (RMA), Process Change Notification (PCN) and Product Discontinuation (PD). Evaluation boards are intended to be used under laboratory conditions and by trained specialists only.

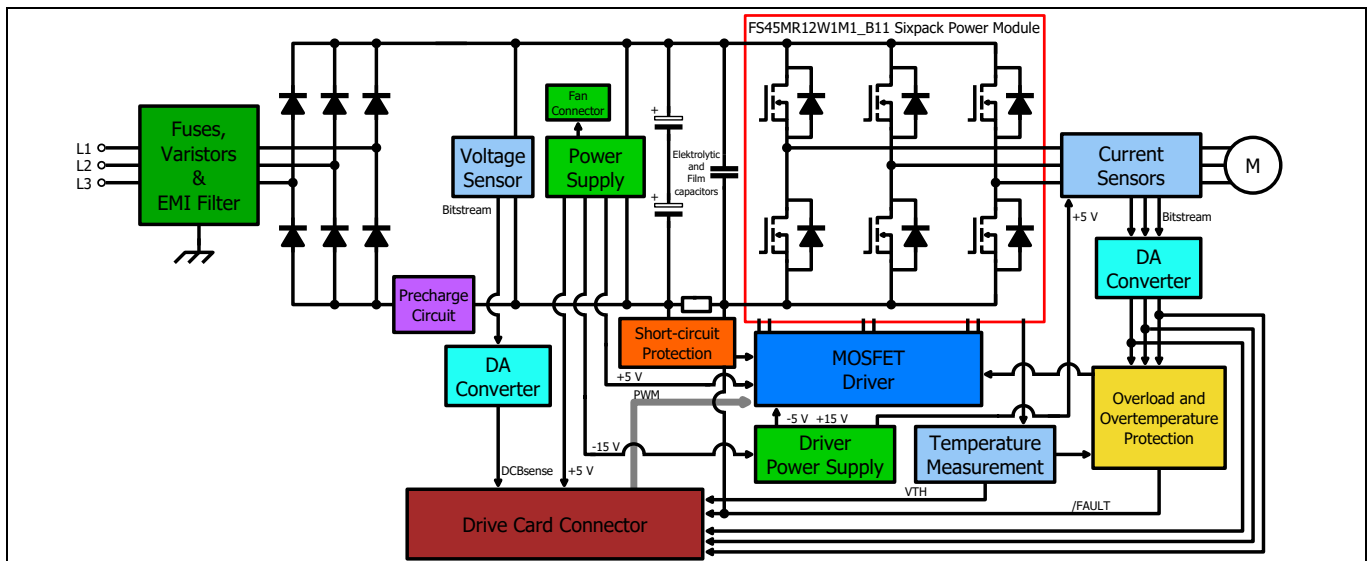

Figure 1 The block diagram of the Eval-M5-E1B1245N-SiC

The block diagram of the Eval-M5-E1B1245N-SiC is depicted in Figure 1. This evaluation board includes an EMI filter, a line rectifier with a soft power-up circuit, an auxiliary power supply to provide 5 V, and the silicon carbide sixpack power module FS45MR12W1M1_B11. All measuring and control signals are available on a 32-pin drive card interface connector. The hardware circuit relative to overtemperature and overcurrent protection is also included in this power board.

The signal part of the evaluation board is fully separated from the power part by a basic insulation. Whereas the power components are connected to the mains, the signal part is earthed by the input connector. The design can be easily upgraded to a safe electrical insulation by replacing the present MOSFET drivers and the auxiliary power supply transformer (T650, TR200, TR201) by parts with an appropriate safety approval.

Design features

3 Design features

Eval-M5-E1B1245N-SiC is an evaluation board for motor drive applications comprising the silicon carbide sixpack power module FS45MR12W1M1_B11. Combined in a kit with one of the available MADK control board options, it demonstrates Infineon's silicon carbide power-module technology.

Main features:

- EasyPACK™ 1B 1200 V / 45 mΩ sixpack module with CoolSiC™ MOSFET
- Lead-free terminal plating; RoHS compliant
- Low inductive design
- Integrated NTC temperature sensor

The evaluation board characteristics are:

- Input voltage 340~480 V_{AC}
- Maximum 7.5 kW motor power output
- On-board EMI filter
- Basic insulation between power and signal part
- Isolated current sensing with $\Delta\Sigma$ -ADC
- Isolated sensing of dc-link voltage by $\Delta\Sigma$ -ADC
- Thermistor output
- Overload and short-circuit hardware protection
- Overtemperature hardware protection
- All six switches turn off during protection
- Rugged gate driver technology with stability against transient and negative voltage
- Auxiliary power supply with 5 V
- Measurement test points compatible with standard oscilloscope probes
- PCB is 259 mm x 204 mm and has four layers of 35 μ m copper each
- RoHS compliant

Design features

Table 2 Eval-M5-E1B1245N-SiC board specifications

Parameters	Values	Conditions / Comments
Input		
Voltage	340 – 480 V _{rms}	
Current	16 A _{rms}	Input 400 V _{AC} , T _a = 25 °C
Output		
Power (3 phases) maximal with mains line choke	7.5 kW	Input 400 V _{AC} , f _{PWM} = 18 kHz, T _a = 25°C, T _h = 70°C, forced convection cooling
Power (3 phases) without mains line choke	6 kW	Input 400 V _{AC} , f _{PWM} = 18 kHz, T _a = 25°C, T _h = 70°C, forced convection cooling, limited by input current
Current per leg at f _{nom}	16 A _{rms}	Input 400 V _{AC} , f _{PWM} = 18 kHz, T _a = 25°C, T _h = 70°C, forced convection cooling
Current per leg at f _{max}	8 A _{rms}	Input 400 V _{AC} , f _{PWM} = 100 kHz, T _a = 25°C, T _h = 70°C, forced convection cooling
DC bus voltage		
Typical DC bus voltage	530 V – 670 V	
Brown-in Aux supply	480 V	
Brown-out Aux supply	300 V	Minimum required voltage to use the internal low voltage power supply
Maximum DC bus voltage	690 V	
Switching frequency		
Nominal switching frequency f _{nom}	18 kHz	
Maximal switching frequency f _{max}	100 kHz	
Current feedback		
Analogue output	18.41 mV/A	
Digital output	3.3 V	ΔΣ bitstream @ 20 MHz
DC link voltage feedback		
Analogue output	1.257 mV/V	
Digital output	3.3 V	ΔΣ bitstream @ 20 MHz
Protection		
Output current trip level	32 A _{peak}	Disables driver stage for 30 ms
Temperature trip level	100 °C	Disables driver stage for 30 ms
On board power supply		
+5 V	± 2 %	Used for primary side of MOSFET drivers and for the controller board
+6 V	± 10 %	Used for analogue circuits
-5 V	± 10 %	Used for analogue circuits
-15 V	± 5 %	Used for driver supply

Design features

Parameters	Values	Conditions / Comments
System environment		
Ambient temperature	From 0 to 50 °C	Non-condensing, maximum RH of 95 %
PCB characteristics		
Material	FR4, 1.6 mm thickness	4 layers, 35 µm copper thickness
Dimensions	259 mm x 204 mm	

3.1 Functional groups

The next two figures illustrate the functional groups on the top and bottom side of the evaluation board. The functional groups are explained in Table 3.

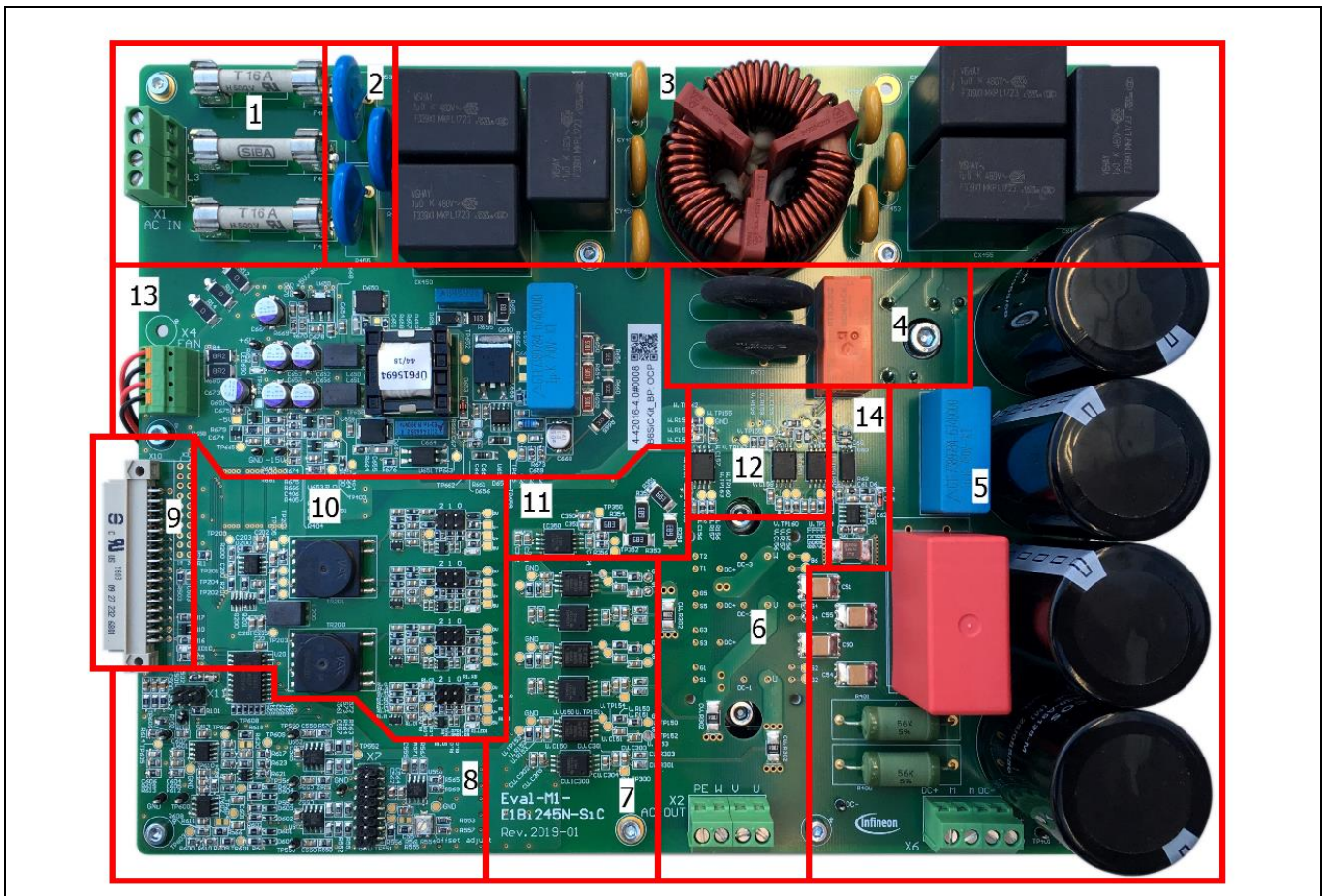

Figure 2 Top view of the Eval-M5-E1B1245N-SiC

Design features

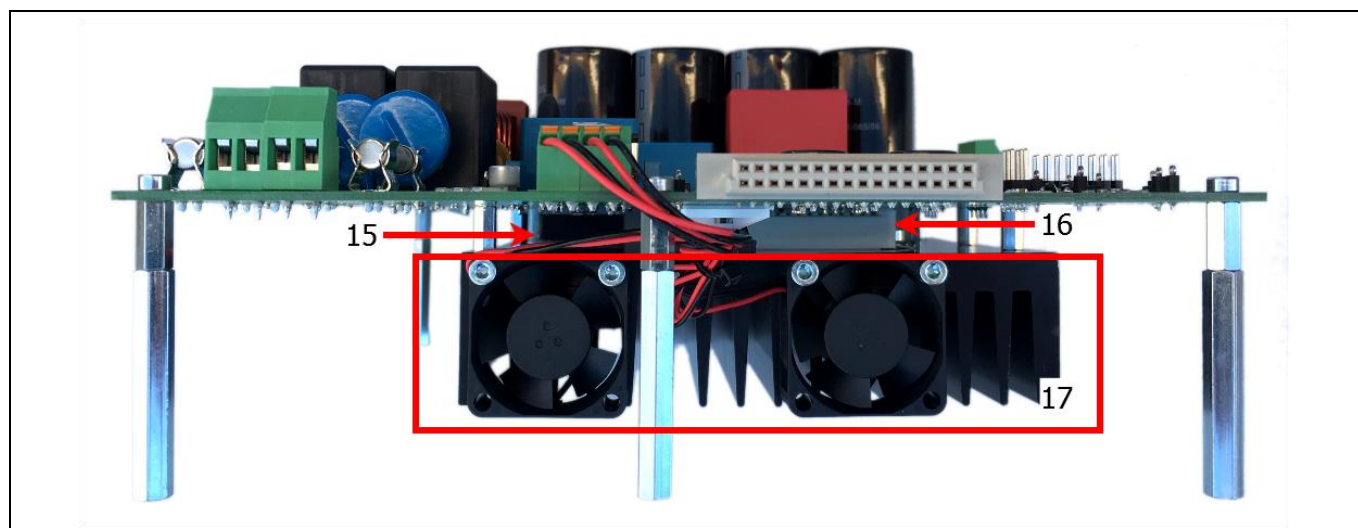

Figure 3 Side view of the Eval-M5-E1B1245N-SiC

Table 3 Functional groups of Eval-M5-E1B1245N-SiC

Nr.	Functional groups
1	AC input connector with fuses
2	Varistors for overvoltage protection
3	EMI filter
4	Rectifier with precharge relay and precharge NTC resistors
5	DC-bus capacitors, balancing resistors and DC-bus connector
6	Power module FS45MR12W1M1_B11 with phase current shunts
7	High-side MOSFET drivers with $\Delta\Sigma$ -DACs for shunt sensors
8	Low-pass filter of $\Delta\Sigma$ -signals and overcurrent comparators
9	Connector for controller
10	Isolated power supply for MOSFET drivers
11	DC-bus voltage measurement with $\Delta\Sigma$ -DAC
12	Low-side MOSFET drivers
13	Flyback converter for auxiliary supply
14	Overcurrent detection and measuring shunt
15	Rectifier mounted on heatsink
16	Power module mounted on heatsink
17	Heatsink with fans

Design features

3.2 Pin assignment

General information about the connectors of the Eval-M5-E1B1245N-SiC evaluation board is reported.

Table 4 includes the details of the AC input connector X1.

Table 4 X1 – AC line connector

No.	Pin	Details
1	Line phase 1	
2	Line phase 2	
3	Line phase 3	
4	EARTH	

Table 5 provides the details of the motor side connector X2.

Table 5 X2 – Motor side connector

No.	Pin	Details
1	EARTH	Connect to X1/4 via heatsink No connection without heatsink!
2	U	Connect to motor phase W
3	V	Connect to motor phase V
4	W	Connect to motor phase U

Table 6 provides the pin assignments of driver board connector X10. This connector is the interface to the controller board.

Table 6 X10 – Power board connector

No.	Pin	Details
A1	-	-
A2	-	-
A3	-	-
A4	-	-
A5	-	-
A6	-	-
A7	-	-
A8	-	-
A9	-	-
A10	I_W	Phase W current sense output, scale 76.56 mV/A, offset 2.5 V
A11	I_V	Phase V current sense output, scale 76.56 mV/A, offset 2.5 V
A12	I_U	Phase U current sense output, scale 76.56 mV/A, offset 2.5 V
A13	-	-
A14	-	-
A15	-	-
A16	GND	Ground

Design features

No.	Pin	Details
B1	/ENABLE	/ENABLE signal – if high drivers are disabled
B2	/FAULT	/FAULT signal – active low when overcurrent or overtemperature is detected
B3	PWMWH	3.3 V compatible logic input for high-side gate driver-Phase W
B4	PWMWL	3.3 V compatible logic input for low-side gate driver-Phase W
B5	PWMVH	3.3 V compatible logic input for high-side gate driver-Phase V
B6	PWMVL	3.3 V compatible logic input for low-side gate driver-Phase V
B7	PWMUH	3.3 V compatible logic input for high-side gate driver-Phase U
B8	PWMUL	3.3 V compatible logic input for low-side gate driver-Phase U
B9	-	-
B10	-	-
B11	-	-
B12	-	-
B13	DCBsense	DC bus voltage sense output, scale 5 mV/V (1/200)
B14	VTH	Thermistor voltage output, 100°C = 0.448 V
B15	-	-
B16	VCC	On board 5 V supply, max. 120 mA

Table 7 denotes the details of the fan connector X4. The connector is provided for two fans with a nominal voltage of 12 V cooling the heatsink. The maximum output current is limited to 180 mA. The connector is connected via two series resistors to a supply of 15 V. Consequently, it is possible to drive most fans with a nominal voltage of 12 V in the power range of 0.6 W to 1 W in their allowed voltage range.

Table 7 X4 – DC bus connector

S. No.	Pin	Details
1	Fan1-	Connected via 8.2 Ω resistor to -15 V, max. 180 mA
2	Fan1*	Connected via 8.2 Ω resistor to GND, max. 180 mA
3	Fan2-	Connected to Fan1-
4	Fan2+	Connected to Fan1+

Table 8 includes the details of the DC bus connector X6.

Table 8 X6 – DC bus connector

S. No.	Pin	Details
1	DC+	Connected to positive side of DC-bus capacitor
2	DC M	Connected to midpoint of DC-bus capacitor
3	DC- M	Do not connect load at this point!
4	DC-	Connected to negative side of DC-bus capacitor

Design features

The following table provides the details of the X7 digital measurement connector.

Table 9 X7 – $\Delta\Sigma$ measurement connector

S. No.	Pin	Details
1	Clock_lu	20 MHz clock output, signal level 5 V
2	GND	
3	DS_lu	$\Delta\Sigma$ modulated output of current measurement, phase U, signal level 5 V, 50% positive equals 0 A, 89.06% positive equals +25 A, 10.94% positive equals -25 A
4	GND	
5	Clock_lv	20 MHz clock output, signal level 5 V
6	GND	
7	DS_lv	$\Delta\Sigma$ modulated output of current measurement, phase V, signal level 5 V, 50% positive equals 0 A, 89.06% positive equals +25 A, 10.94% positive equals -25 A
8	GND	
9	Clock_lw	20 MHz clock output, signal level 5 V
10	GND	
11	DS_lw	$\Delta\Sigma$ modulated output of current measurement, phase W, signal level 5 V, 50% positive equals 0 A, 89.06% positive equals +25 A, 10.94% positive equals -25 A
12	GND	
13	Clock_Vdc	20 MHz clock output, signal level 5 V
14	GND	
15	DS_Vdc	$\Delta\Sigma$ modulated output of DC link voltage measurement, signal level 5 V, 50% positive equals 0 V, 89.06% positive equals 851 V
16	GND	

Design features

3.3 Analogue measurement adjustment

In order to achieve a precise measurement of the output currents and a symmetric overcurrent detection, the offset voltage of the analogue signals must be adjusted. All relevant parts for the adjustment of the offset voltage are shown in Figure 4.



Figure 4 Relevant parts for offset adjustments

The DC-bus voltage measurement has only a small deviation; consequently, there is no offset compensation necessary.

To adjust the current offset, simply vary R554 at no load until either the software readings of the currents are zero or the voltages at the currents' test points reach almost 2.5 V. Due to component tolerances, an exact adjustment of all three currents to zero at the same time will not be possible.

Additional information about the circuit itself can be found in the chapter “Digital to analogue converter”.

Schematics and layout

4 Schematics and layout

4.1 Overview

An overview of the board's schematics is given in Figure 5. Basically, the schematic can be divided into four subcategories: the input circuit of the converter, the auxiliary supply, the power stage and the measurements. The external controller board has to be connected to the evaluation board by the X10 driver board connector. The logical ground is connected to earth by the resistors R12 to R14.

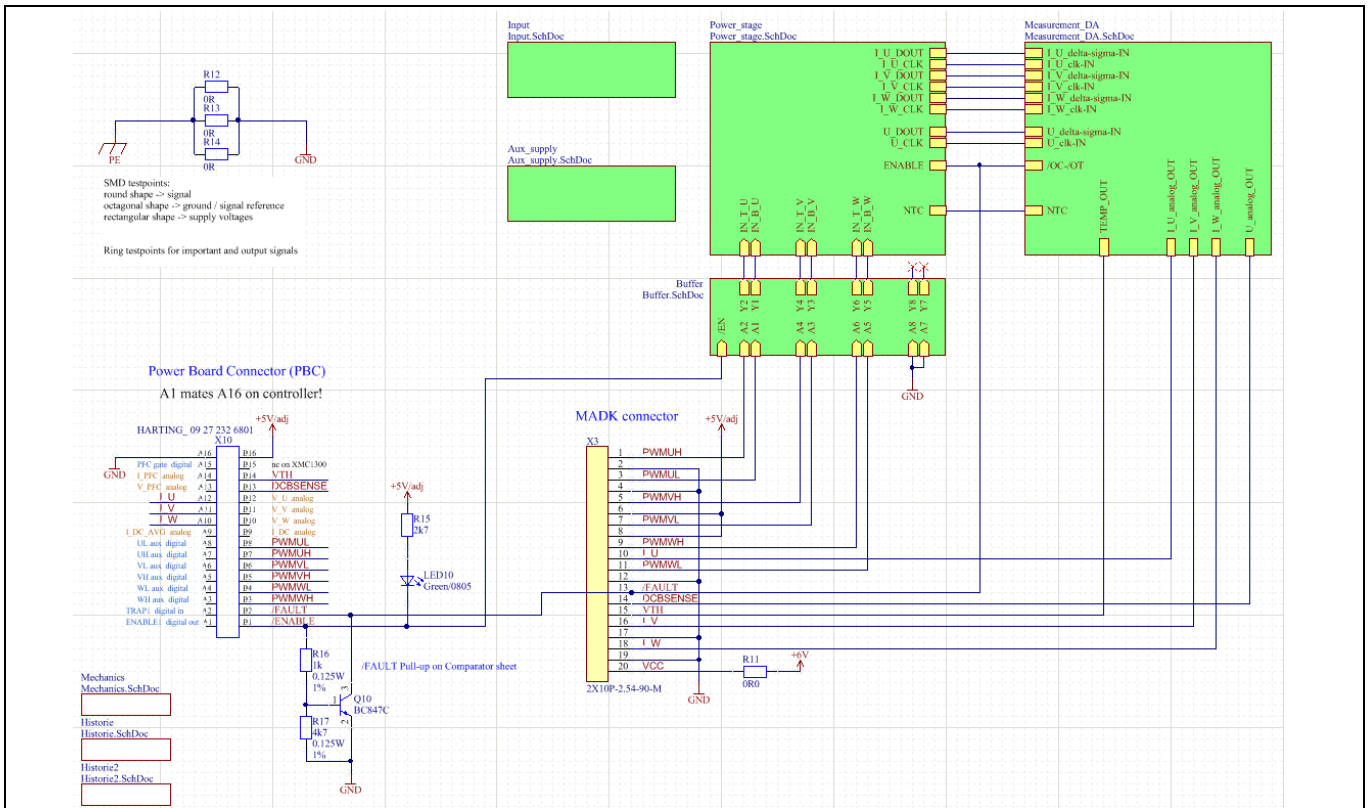

Figure 5 Overview and driver board connector

4.2 Input circuit

The input circuit is shown in Figure 6. It is equipped with two NTC resistors which limit the inrush current. The resistors are bypassed after the start of the auxiliary supply and a constant delay time. The DC-bus consists of four electrolytic capacitors and one film capacitor as well as four ceramic capacitors for the high-frequency ripple currents. The electrolytic capacitors are series-connected and balanced with two resistors.

Schematics and layout

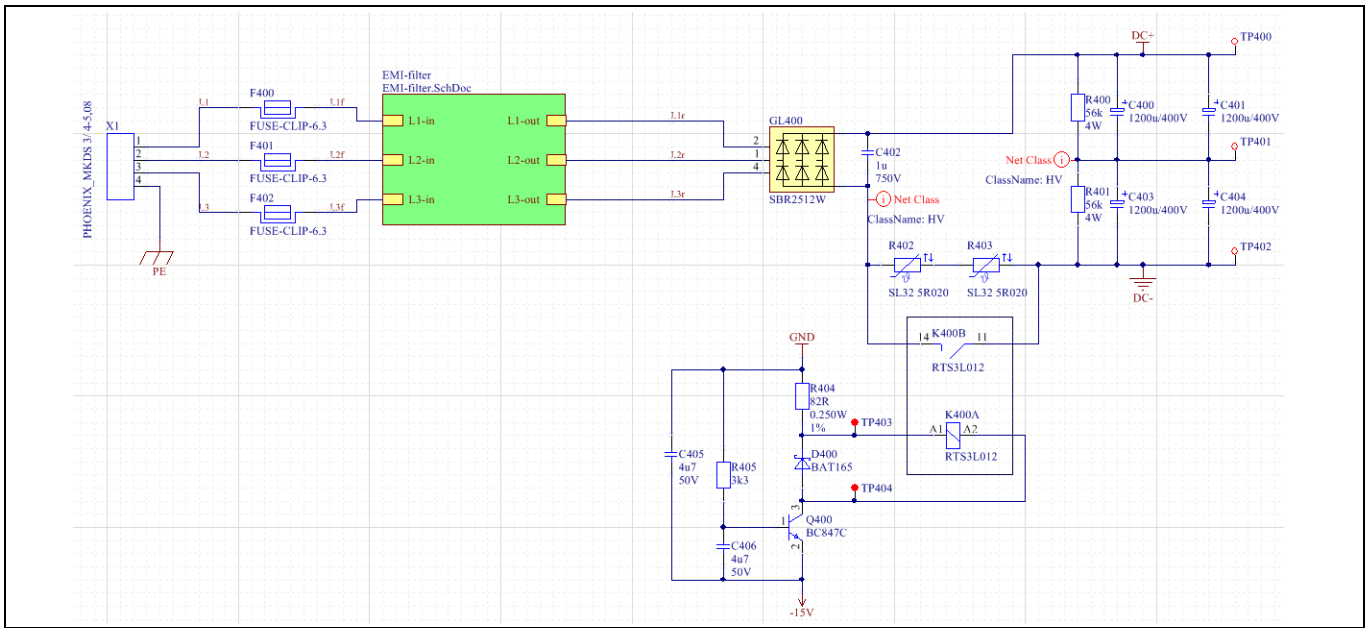

Figure 6 Mains input and precharge circuit

4.3 EMI filter

The Eval-M5-E1B1245N-SiC is equipped with an EMI filter circuit to present a complete solution. Please note that the board is not qualified for connection to public grids. A laboratory power supply, an isolation transformer or any other isolation device is required. The circuit is depicted in Figure 7.

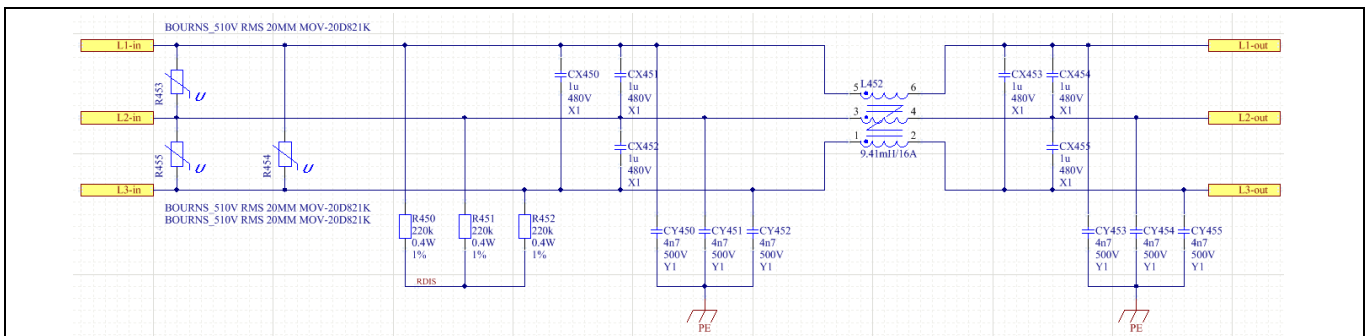

Figure 7 EMI filter

The EMI filter is designed to minimize high-frequency emissions to the connected grid. Lower harmonics of the grid current are not suppressed. An additional mains line choke must be used to fulfil harmonic standards. In addition, a mains line choke reduces the crest factor of the input current. Hence, an external choke allows higher rms input currents leading to a higher output power. Without an additional mains line choke, an output power of approx. 6 kW can be achieved at 400 V line voltage.

However, the conducted EMI emission strongly depends on several operating conditions like the connected motor, used switching frequency, etc. Consequently, the implemented filter does not necessarily meet the required standard. If necessary, a Vacuumschmelze W 424-53 ring core, or similar, with three turns, can be added to the supply lines as a common mode choke to further reduce the conducted EMI.

Schematics and layout

4.4 Auxiliary supply

All supply voltages are generated by a flyback converter, supplied from the DC-bus. It starts operation at a bus voltage of $477 V_{dc}$, which corresponds to approximately $340 V_{ac}$ input voltage. The supply circuit is implemented with an Infineon ICE5QSAG control IC. The supply voltages are isolated from the DC-bus potential by a basic insulation. The complete schematic is shown in Figure 8.

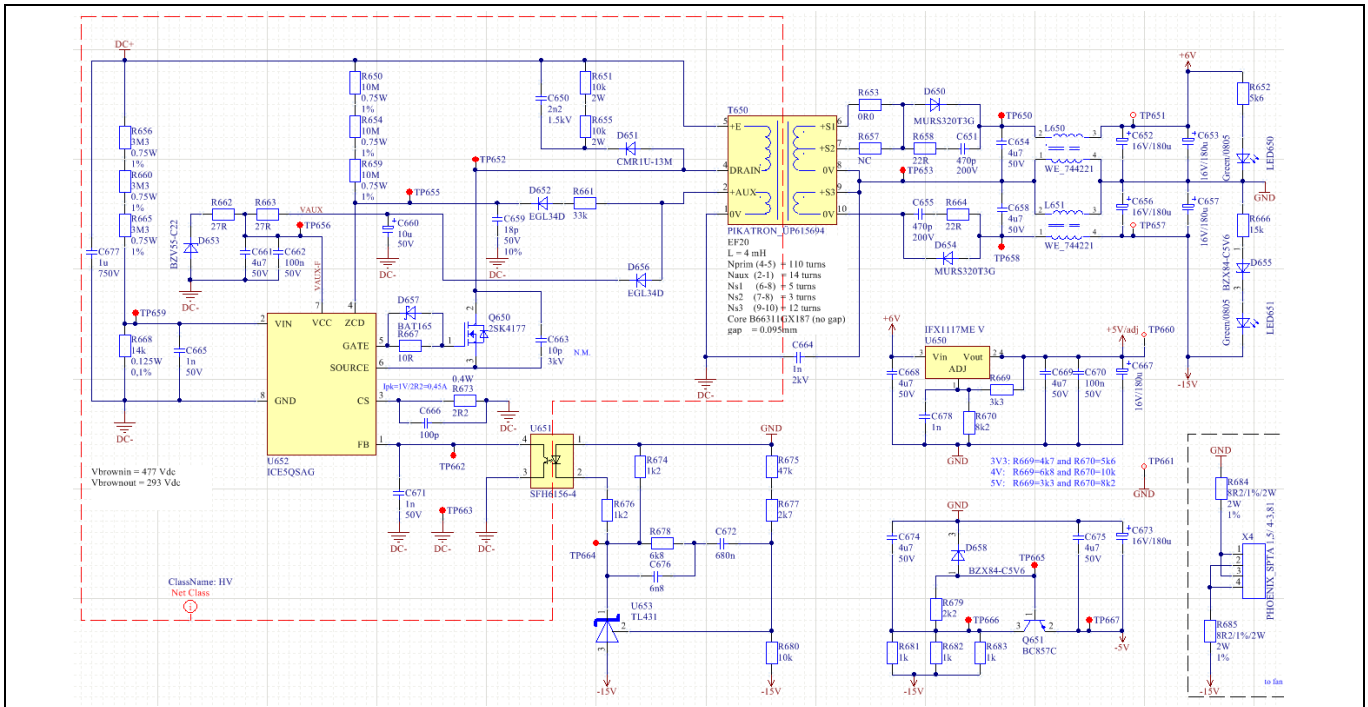

Figure 8 Auxiliary supply

The flyback converter generates three voltages. The auxiliary winding on the primary side of the transformer generates an unregulated 17.6 V supply for the control IC itself. On the transformer’s secondary side, two output voltages are generated: a regulated 15 V and indirect regulated +6 V. The 15 V supply voltage is mainly used for the MOSFET driver supply circuit. From this voltage, a -5 V supply voltage is derived by a linear regulator used for the negative supply for the analogue circuitry of the board. The positive analogue supply is directly connected to the +6 V supply. This voltage rail is also used to generate the +5 V for the controller and overcurrent threshold generations.

If the Eval-M5-E1B1245N-SiC is to be used with low DC-bus voltages below the start-up threshold of the flyback converter, it is possible to supply it with an external power supply. Therefore the test points TP651, TP656 and TP661 can be used. These test points are labelled with their corresponding voltage on the PCB. The points are depicted in Figure 9.

Schematics and layout

4.6 Driver circuit

Each of the six MOSFETS is driven by Infineon’s MOSFET EiceDRIVER 1EDI20H12AH without any special circuitry at the output. The positive input is protected by an additional glitch filter and a pull-down resistor. All negative inputs are connected together and are used for a global /ENABLE signal. The circuit which is used for each phase leg is shown in Figure 11.

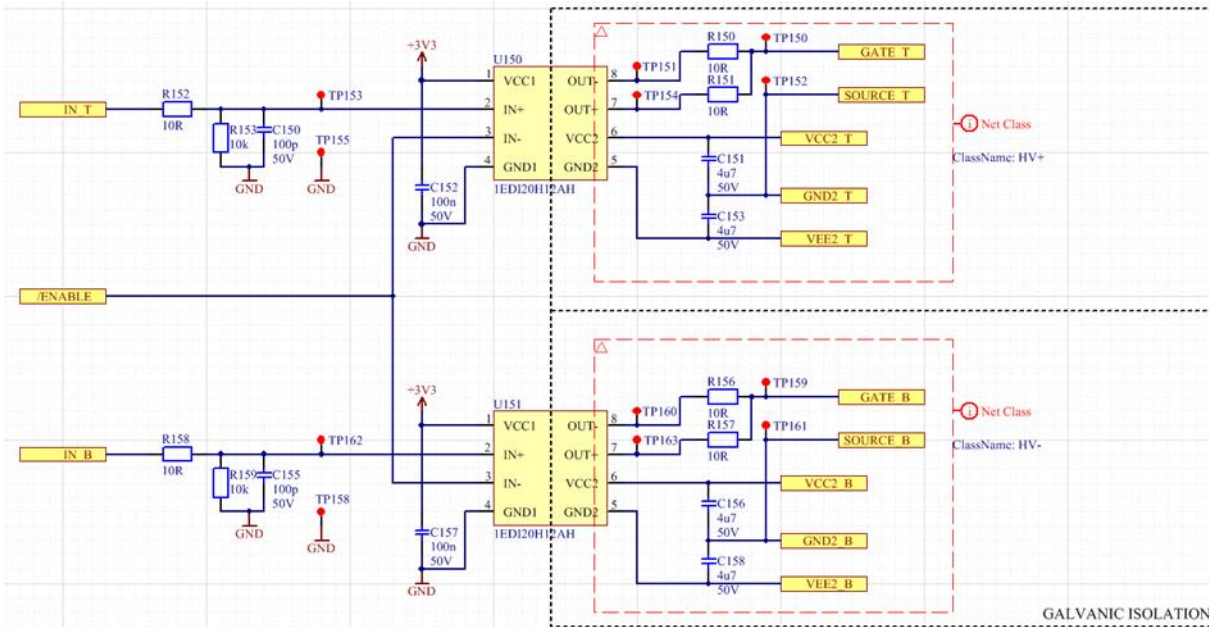

Figure 11 Driver circuit for one-phase leg

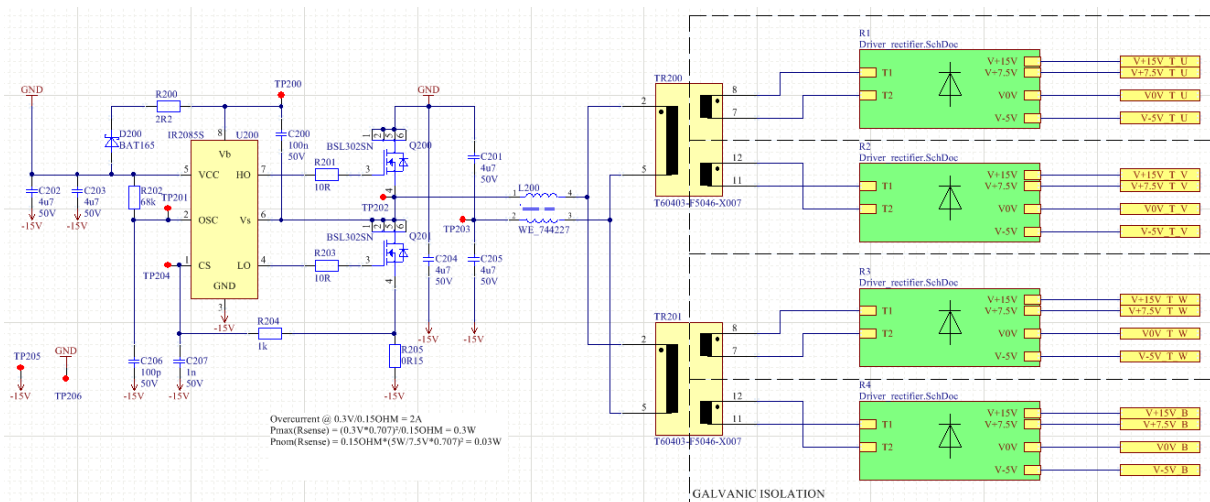

Figure 12 Driver power supply

Schematics and layout

The rectifier circuit generates three voltage levels for each driver: a regulated negative voltage for safely turning off the power MOSFET, +15 V for turning on the power MOSFET, and additionally +5 V for the additional current and voltage measurement. The circuit is shown in Figure 13.

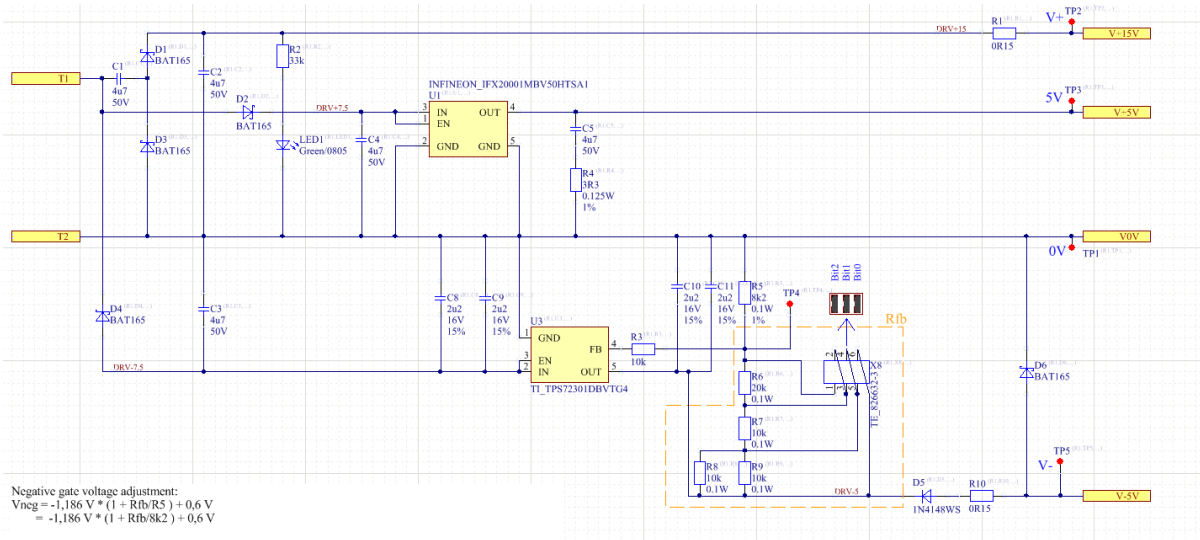

Figure 13 Rectifier circuit of driver power supply

The regulated negative voltage can be adjusted in eight steps by placing jumpers on the X8 pin header. This adjustment must be done for each rectifier circuit separately. By placing the jumpers in this way, the feedback resistor of the negative voltage regulator is changed. Consequently, its output voltage can be adjusted. The selectable voltages are shown in Table 10.

Additionally, it is possible to use real 0 V turn-off voltage if R10 is removed and TP1 is connected to TP5. Be careful when adjusting the negative voltage! Load conditions might occur which could lead to the undesired turn-on of the power switches.

The jumpers must not be changed under switching conditions.

Table 10 X8 pin header negative gate voltage selection

Jumper setting	Negative gate voltage
	-5.6 V
	-4.9 V
	-4.2 V
	-3.5 V
	-2.8 V

Schematics and layout

Jumper setting	Negative gate voltage
	-2.0 V
	-1.3 V
	-0.6 V

4.7 Thermistor output

The temperature of the power module is measured with the module-integrated NTC resistor. The NTC resistor is connected to 5 V via a series resistor of 10 kΩ. The resulting NTC voltage is fed to the control board via an amplifier with a voltage gain of two. If necessary, the signal level can be changed by exchanging the resistors R617, R620, R621 and R623. The evaluation circuit is depicted in Figure 14.

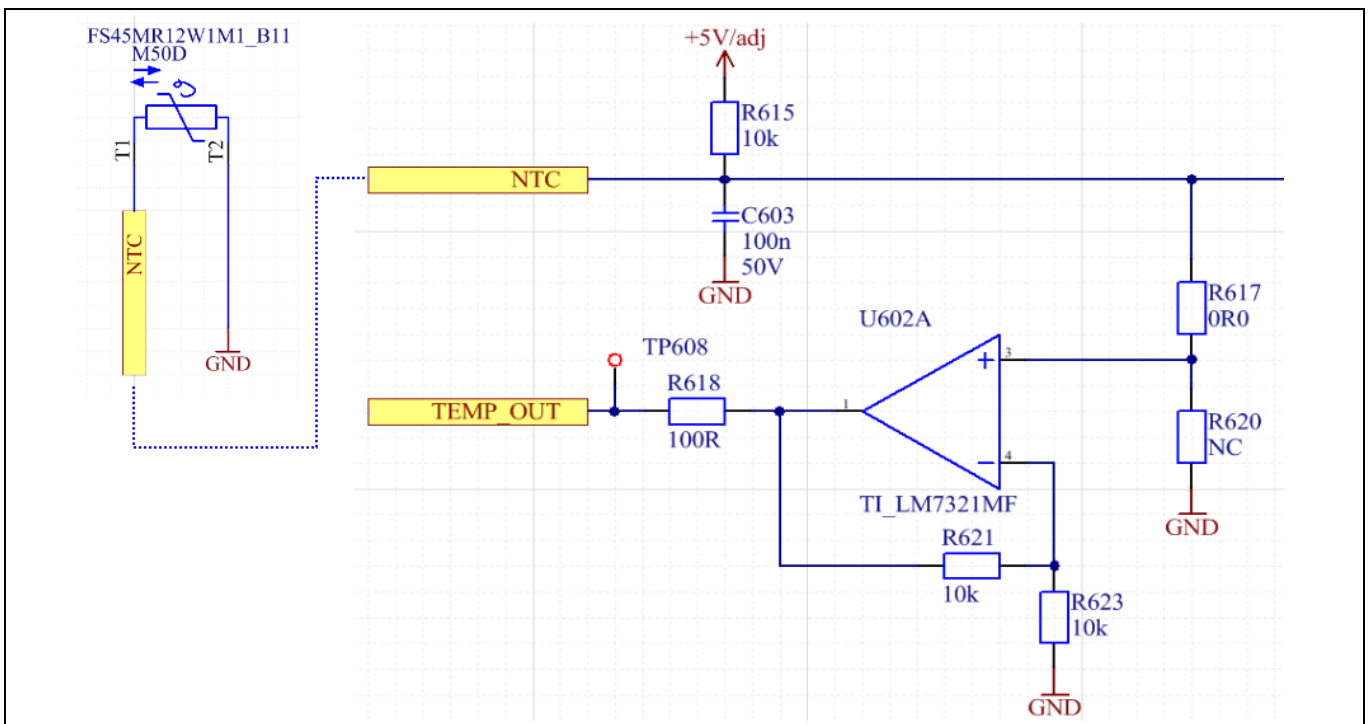

Figure 14 Evaluation circuit for NTC measurement

The dependency of the generated output voltage vs. the power module temperature is shown in Figure 15.

Schematics and layout

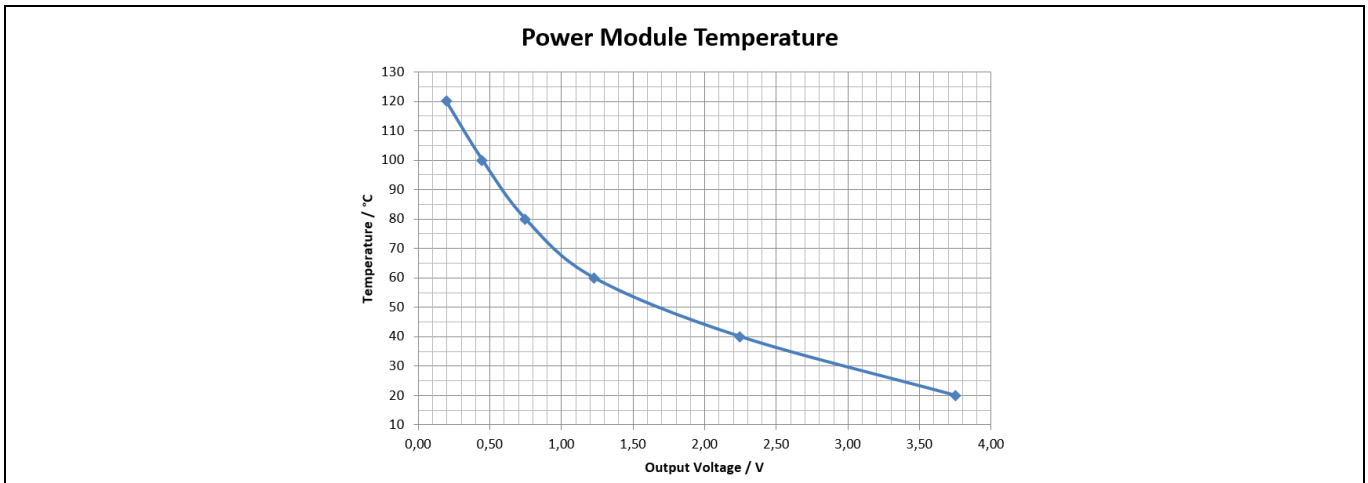

Figure 15 Power module temperature output

4.8 Current measurement

The three-phase currents are measured by shunt resistors. Each shunt voltage is measured by a galvanically isolated $\Delta\Sigma$ -modulator. The modulator generates a $\Delta\Sigma$ -modulated bitstream output with a clock frequency of 20 MHz. The circuit can be seen in Figure 16. The modulator is supplied via the +5 V output from the rectifier circuit.

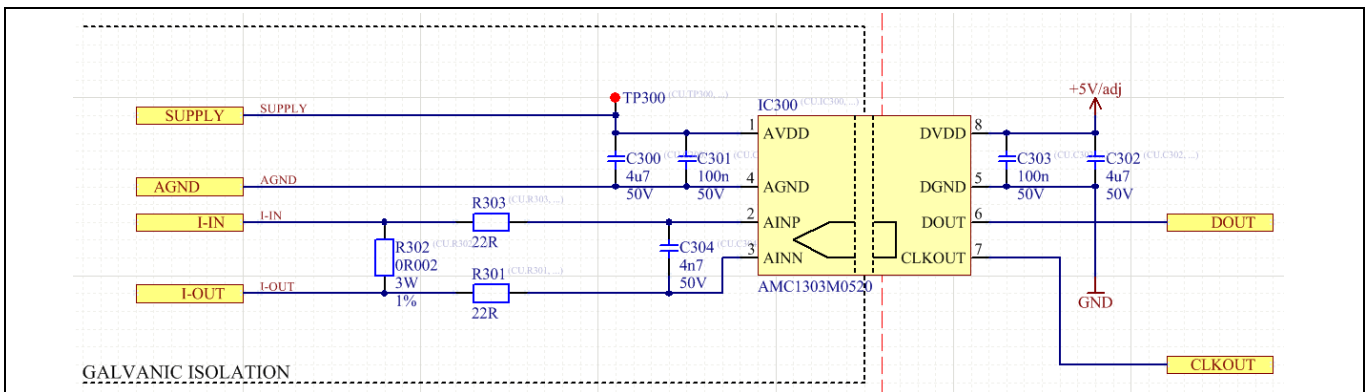

Figure 16 Phase-current measurement

4.9 Voltage measurement

Similar to the current measurement, the DC-bus voltage is measured via a voltage divider and the galvanically isolated $\Delta\Sigma$ -modulator. The circuit can be seen in Figure 17.

Schematics and layout

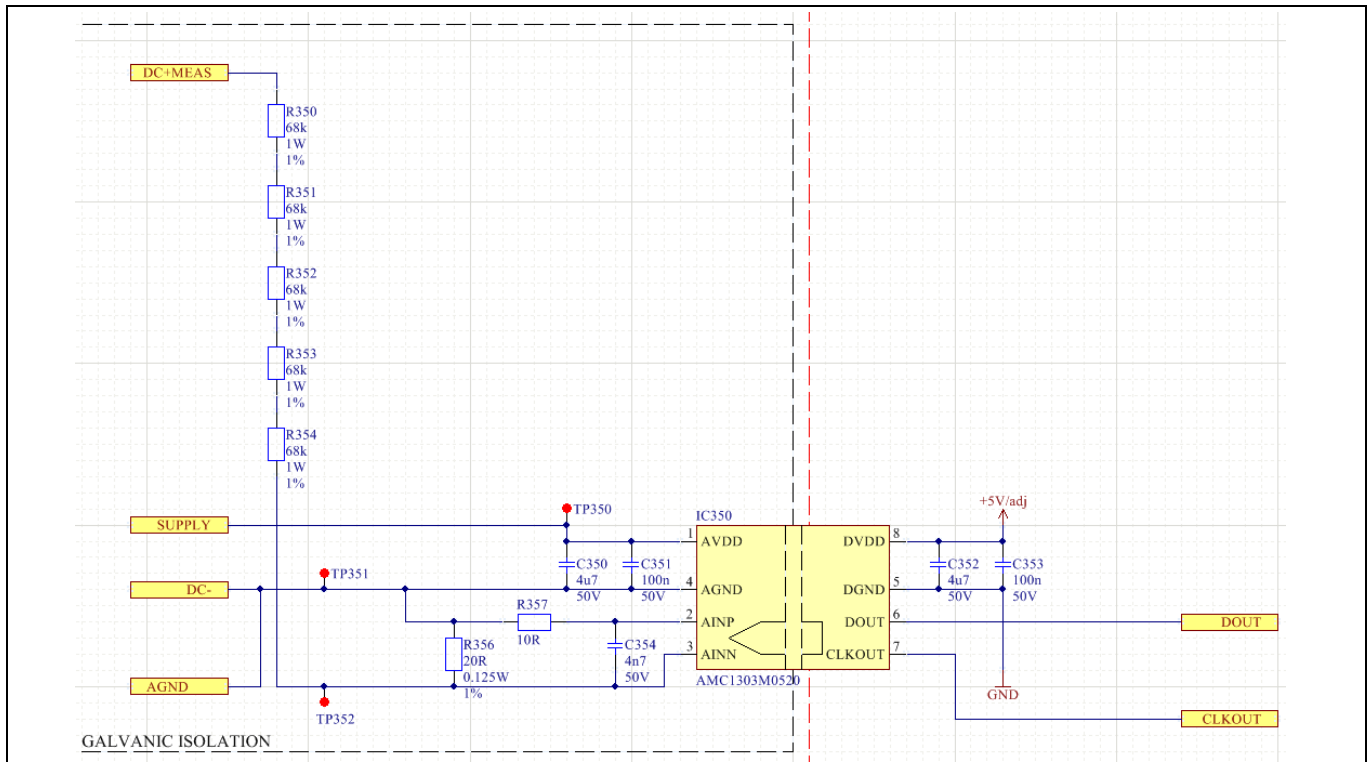

Figure 17 DC-bus voltage measurement

Schematics and layout

4.10 Digital-to-analogue converter

The evaluation board contains four discrete digital-to-analogue converters to generate analogue signals from the digital $\Delta\Sigma$ -modulated bit streams. The analogue signals are used for the on-board protection as well as for the external controller. The conversion is done by second-order low pass filters with approximately 6.5 kHz bandwidth. The circuit is shown in Figure 18. At zero input, the $\Delta\Sigma$ -converter generates a bitstream with 50% duty cycle. For offset adjustment, the reference voltage of the low pass filters can be adjusted via the R5564 potentiometer for all three currents.

The four $\Delta\Sigma$ -modulated bitstreams can be measured directly at the X7 pin headers.

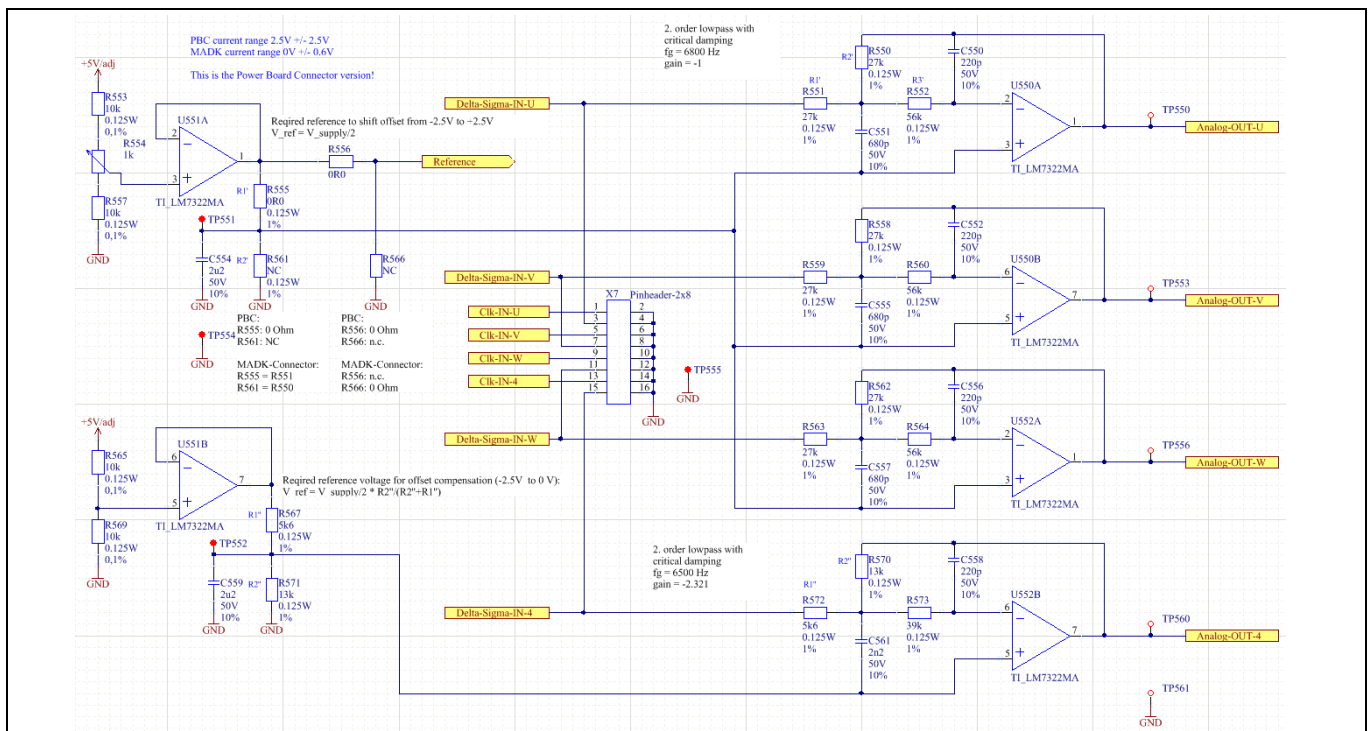

Figure 18 Measurement digital-to-analogue conversion

The Eval-M5-E1B1245N-SiC evaluation board is equipped with an overcurrent and overtemperature protection. If an overcurrent or overtemperature event is detected, the /FAULT signal is pulled low and the MOSFET drivers are simultaneously disabled for around 30 ms. The circuit is depicted in Figure 19.

Schematics and layout

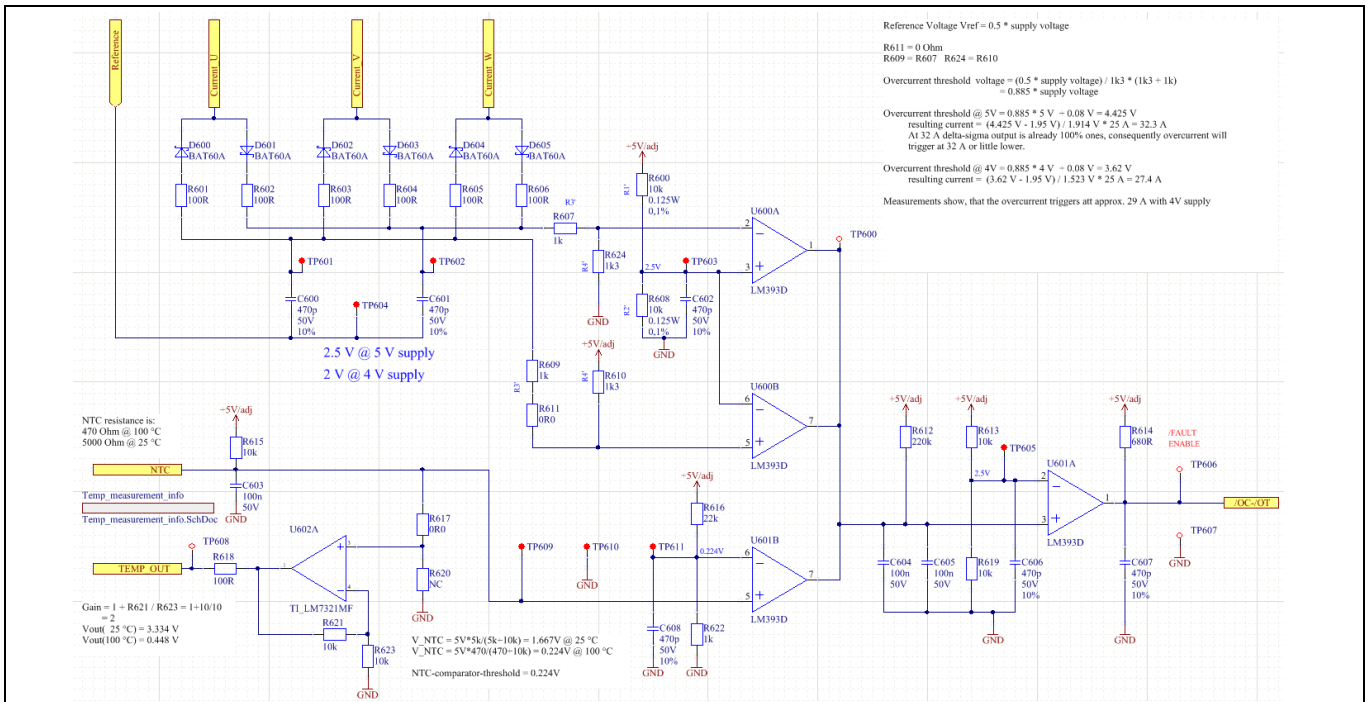

Figure 19 Protection circuit and temperature measurement

The overcurrent detection is provided with six ultra-low forward-voltage drop diodes (D600 ... D605) which rectify the peak current of each phase. The peak positive value and the peak negative value are compared with a threshold value. If one value is exceeded, the /FAULT signal is triggered.

The overtemperature detection directly monitors the NTC voltage. A voltage below 0.224 V triggers the /FAULT signal. This threshold corresponds to a measured temperature of 100°C.

4.11 Overcurrent / Short-circuit protection

The circuit which monitors the voltage across a 3 mΩ shunt placed in the DC-path of the power module is shown in Figure 20. A low-side driver with an overcurrent protection feature is used here. The driver stage itself is unused. The Infineon 1ED44176N01F has 0.5 V overcurrent trigger threshold. This leads to a nominal current threshold of 167 A.

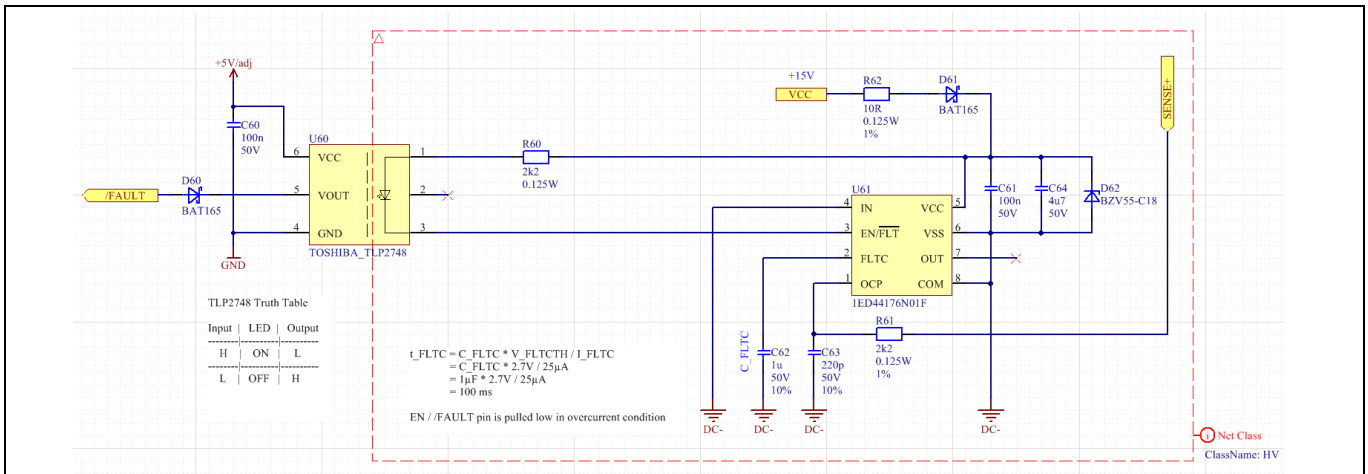

Figure 20 Short-circuit protection

Schematics and layout

A low pass filter (R61/C63) is placed at the OCP pin of the IC. Its time constant of 484 ns is required to block high voltage spikes at fast current rises due to the parasitic inductance of the measuring shunt and its connection.

If an overcurrent is detected, the EN/FAULT pin of the driver is pulled low and the LED of the connected optocoupler turns on. Hence, the isolated side of the optocoupler turns low and the /FAULT signal is pulled low. Consequently, all MOSFET drivers are turned off. The overall time delay from overcurrent to MOSFET gate low is approximately 1 µs.

The circuit is supplied via the low-side gate driver supply. This supply is referenced to the source of the low-side MOSFETs which is in front of the shunt. Consequently, the supply of the OCP protection is decoupled with a diode (D61) and buffered with a capacitor (C64). This leads to a voltage drop of approximately 1 V in overcurrent condition, however, this is still sufficient to supply the circuit.

4.12 PCB layout

The layout of this board is especially designed for evaluation purposes. Consequently, it has several test points and is not necessarily suited for continuous operation at full load. The PCB has four electrical layers with 35 µm copper. The size is 204 mm x 259 mm. The PCB thickness is 1.6 mm. For more details on the layout design and the latest Gerber-files, contact our technical support team.

Figure 21 and Figure 22. show the top and bottom assembly of the evaluation board, respectively.

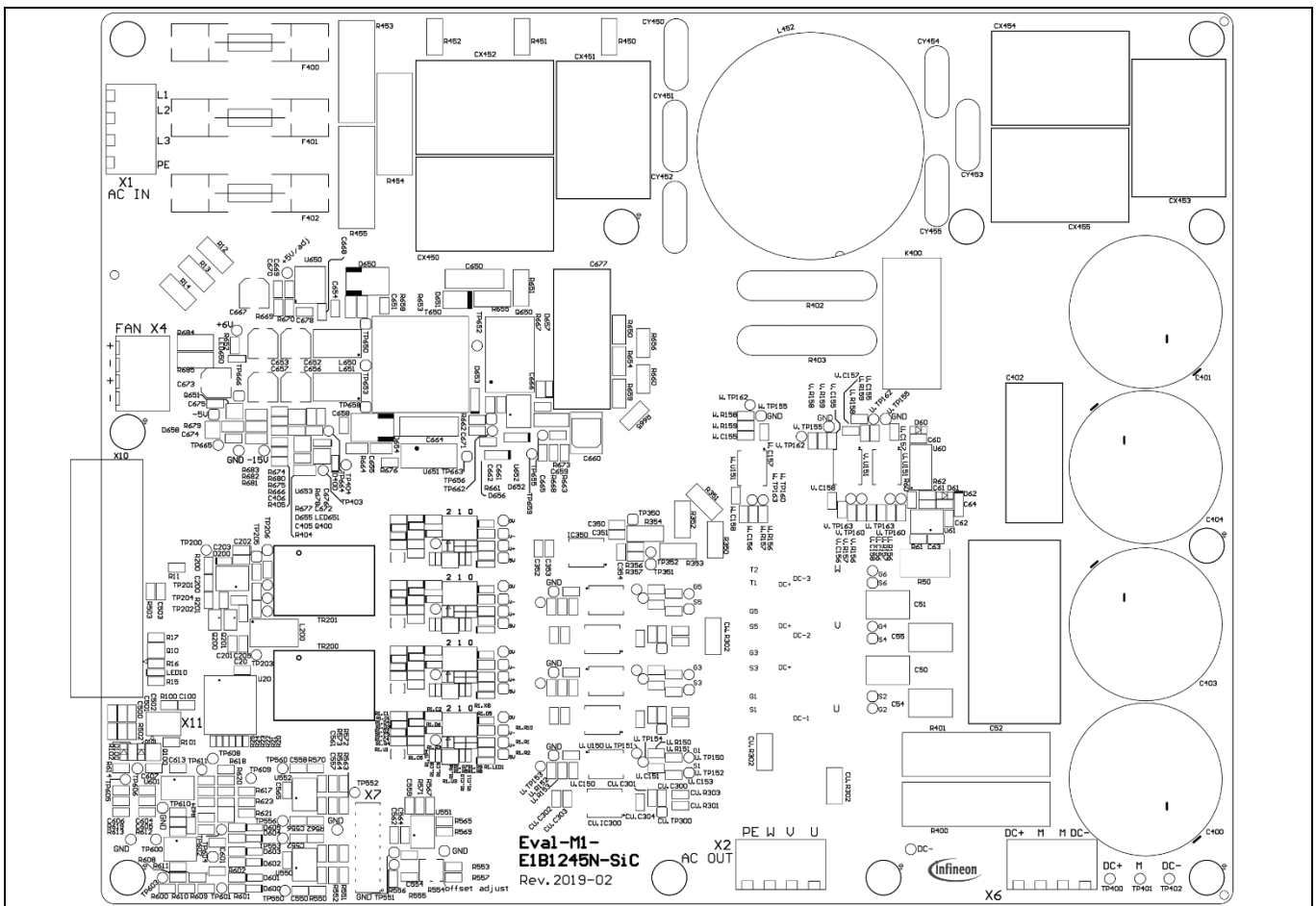

Figure 21 Top assembly print of the Eval-M5-E1B1245N-SiC evaluation board

Schematics and layout

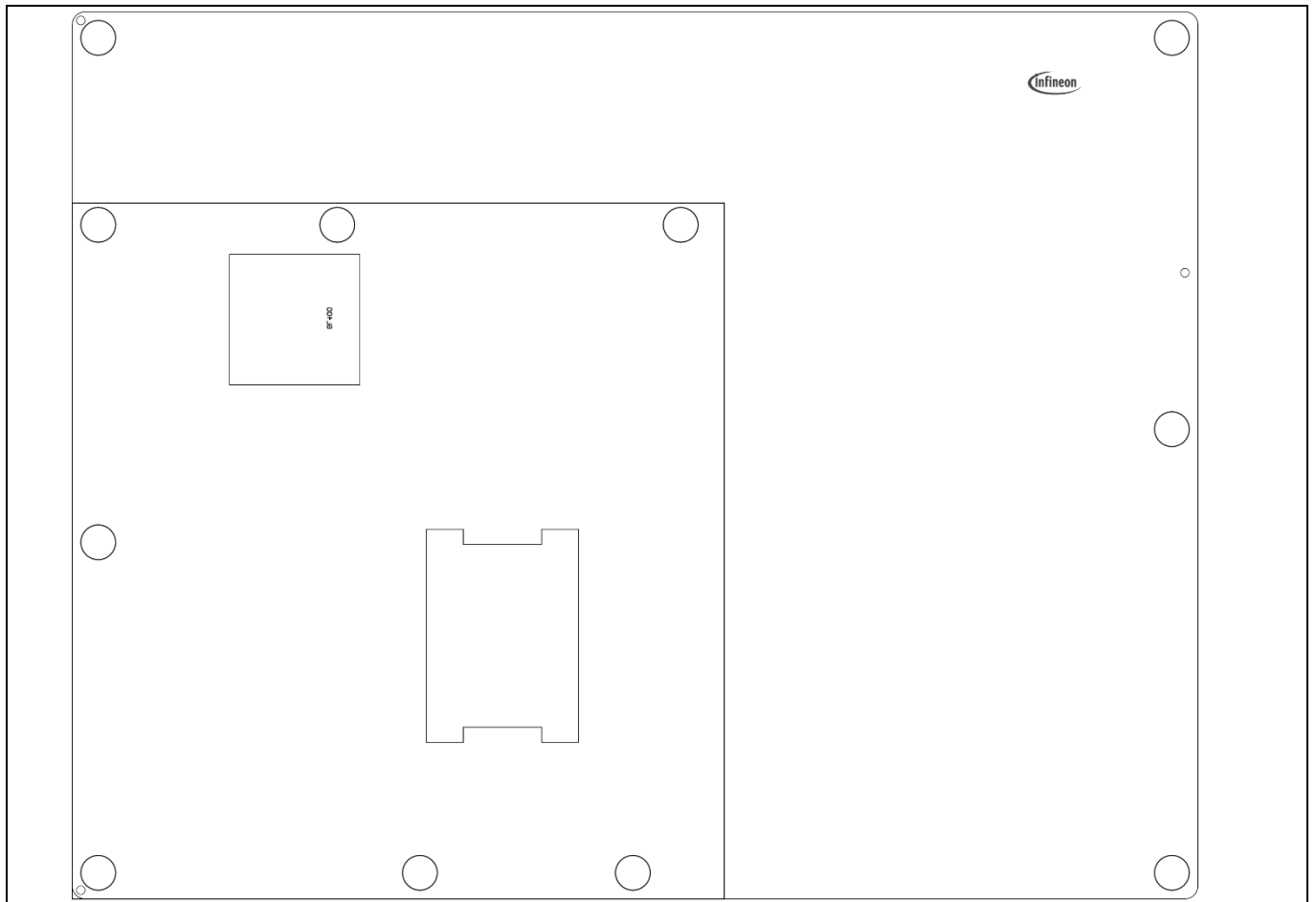

Figure 22 Bottom assembly print of the Eval-M5-E1B1245N-SiC evaluation board

Bill of material

5 Bill of material

Table 11 Bill of material

No.	Qty.	Part description	Designator	Part number	Manufacturer
1	11	SCREW M3: ZYK ISK / 6mm / ST8,8 vz bp	SCREW1, SCREW2, SCREW3, SCREW4, SCREW5, SCREW6, SCREW7, SCREW8, SCREW9, SCREW10, SCREW11		
2	1	SCREW M4: ZYK ISK / 10mm / ST8,8 vz bp	SCREW16		
3	4	SCREW M4: ZYK ISK / 25mm / ST8,8 vz bp	SCREW12, SCREW13, SCREW14, SCREW15		
4	2	SCREW M5: ZYK ISK / 20mm / ST8,8 vz bp	SCREW17, SCREW18		
5	2	WASHER: 4,3mm / ST vz bp	WASHER1, WASHER2		
6	1	WASHER: 5,3mm / ST vz bp	WASHER3		
7	2	SCREW LOCK: M4 / Tellerform gerippt / ST vn	BOLTLOCK1, BOLTLOCK2		
8	1	SCREW LOCK: M5 / Tellerform gerippt / ST vn	BOLTLOCK3		
9	11	SPACER BOLT: M3 / M3 / 12mm / STvz / SW 5,5mm / Freistich	SPACER1, SPACER2, SPACER3, SPACER4, SPACER5, SPACER6, SPACER7, SPACER8, SPACER9, SPACER10, SPACER11	05.13.121	ETTINGER GmbH
10	4	SPACER BOLT: M3 / M3 / 40mm / STvz / SW 6mm	SPACER12, SPACER13, SPACER14, SPACER15	DISTIN3060S-40	Disrelec
11	1	DIODE ZENER: BZV55-C18	D62	BZV55-C18	
12	1	DIODE ZENER: BZV55-B22	D653	BZV55-B22	
13	2	DIODE ZENER: BZX84-C5V6	D655, D658	BZX84-C5V6	
14	27	DIODE SCHOTTKY: BAT165	D60, D61, D100, D101, D200, D400, D657, R1.D1, R1.D2, R1.D3, R1.D4, R1.D6, R2.D1, R2.D2, R2.D3, R2.D4, R2.D6, R3.D1, R3.D2, R3.D3, R3.D4, R3.D6, R4.D1, R4.D2, R4.D3, R4.D4, R4.D6	BAT165	Infineon
15	6	DIODE SCHOTTKY: BAT60A	D600, D601, D602, D603, D604, D605	BAT60AE6327HT SA1	Infineon

Bill of material

No.	Qty.	Part description	Designator	Part number	Manufacturer
16	4	DIODE STANDARD: 1N4148WS	R1.D5, R2.D5, R3.D5, R4.D5	1N4148WS	
17	2	DIODE STANDARD: EGL34D-E3	D652, D656	EGL34D-E3	Vishay
18	1	DIODE STANDARD: CMR1U-13M	D651	CMR1U-13M	Central Semiconductor Corp.
19	2	DIODE STANDARD: MURS320T3G	D650, D654	MURS320T3G	ON Semiconductor
20	1	RECT BRIDGE: SBR2512W	GL400	SBR2512W	Multicomp
21	4	IC ADC: AMC1303M0520	CU.IC300, CV.IC300, CW.IC300, IC350	AMC1303M0520	Texas Instruments
22	3	IC OPAMP: LM7322MA	U550, U551, U552	LM7322MA	Texas Instruments
23	1	IC OPAMP: LM7321MF	U602	LM7321MF	Texas Instruments
24	1	IC DRIVER: IR2085	U200	IR2085S	International Rectifier
25	6	IC DRIVER: 1EDI20H12AH	U.U150, U.U151, V.U150, V.U151, W.U150, W.U151	1EDI20H12AH	Infineon
26	1	IC DRIVER: 1ED44176N01F	U61	1ED44176N01F	Infineon
27	1	IC VOLT REG: TL431AFDT	U653	TL431AFDT	NXP
28	1	IC PWM REG: ICE5QSAG	U652	ICE5QSAG	Infineon
29	1	IC VOLT REG: IFX1117ME V	U650	IFX1117ME V	Infineon
30	4	IC VOLT REG: IFX20001MBV50HTSA1	R1.U1, R2.U1, R3.U1, R4.U1	IFX20001MBV50H TSA1	Infineon
31	4	IC VOLT REG: TPS72301DBVTG4	R1.U3, R2.U3, R3.U3, R4.U3	TPS72301DBVTG 4	Texas Instruments
32	2	IC COMPARATOR: LM393D	U600, U601	LM393D	Texas Instruments
33	1	IC LOGIC: 74HCT7541D	U20	74HCT7541D	NXP
34	1	IC OPTOCOUPLE: SFH6156-4T	U651	SFH6156-4T	Vishay
35	1	IC OPTOCOUPLE: TLP2748	U60	TLP2748	Toshiba
36	7	LED: SMD / 0805 / gn	LED10, LED650, LED651, R1.LED1, R2.LED1, R3.LED1, R4.LED1	SMD-G0805-02	Sloan AG
37	3	TRANS NPN: BC847C	Q10, Q100, Q400	BC847C	Infineon
38	1	TRANS PNP: BC857C	Q651	BC857C	Infineon
39	2	MOSFET: BSL302SN	Q200, Q201	BSL302SN	Infineon
40	1	MOSFET: 2SK4177	Q650	2SK4177	ON Semiconductor
41	1	MOSFET-MODULE Easy 1b	M50	FS45MR12W1M1_ B11	Infineon

Bill of material

No.	Qty.	Part description	Designator	Part number	Manufacturer
42	6	RES SMD 0805: 0R0 / 1% / 0,125W	R11, R555, R556, R611, R617, R653		
43	1	RES SMD 0805: 2R2 / 1% / 0,125W	R200		
44	4	RES SMD 0805: 3R3 / 1% / 0,125W	R1.R4, R2.R4, R3.R4, R4.R4		
45	24	RES SMD 0805: 10R / 1% / 0,125W	R62, R101, R201, R203, R357, R667, U.R150, U.R151, U.R152, U.R156, U.R157, U.R158, V.R150, V.R151, V.R152, V.R156, V.R157, V.R158, W.R150, W.R151, W.R152, W.R156, W.R157, W.R158		
46	1	RES SMD 0805: 20R / 1% / 0,125W	R356		
47	6	RES SMD 0805: 22R / 1% / 0,125W	CU.R301, CU.R303, CV.R301, CV.R303, CW.R301, CW.R303		
48	2	RES SMD 0805: 27R / 1% / 0,125W	R662, R663		
49	11	RES SMD 0805: 100R / 1% / 0,125W	R500, R501, R502, R503, R601, R602, R603, R604, R605, R606, R618		
50	1	RES SMD 0805: 680R / 1% / 0,125W	R614		
51	6	RES SMD 0805: 1k0 / 1% / 0,125W	R16, R100, R204, R607, R609, R622		
52	2	RES SMD 0805: 1k2 / 1% / 0,125W	R674, R676		
53	2	RES SMD 0805: 1k3 / 1% / 0,125W	R610, R624		
54	1	RES SMD 0805: 2k2 / 1% / 0,125W	R60		
55	2	RES SMD 0805: 2k7 / 1% / 0,125W	R15, R677		
56	2	RES SMD 0805: 3k3 / 1% / 0,125W	R405, R669		
57	2	RES SMD 0805: 4k7 / 1% / 0,125W	R17, R61		
58	3	RES SMD 0805: 5k6 / 1% / 0,125W	R567, R572, R652		
59	1	RES SMD 0805: 6k8 / 1% / 0,125W	R678		
60	1	RES SMD 0805: 8k2 / 1% / 0,125W	R670		
61	13	RES SMD 0805: 10k / 1% / 0,125W	R102, R613, R615, R619, R621, R623, R680, U.R153, U.R159, V.R153, V.R159, W.R153, W.R159		
62	2	RES SMD 0805: 13k / 1% / 0,125W	R570, R571		
63	1	RES SMD 0805: 15k / 1% / 0,125W	R666		
64	1	RES SMD 0805: 22k / 1% / 0,125W	R616		

Bill of material

No.	Qty.	Part description	Designator	Part number	Manufacturer
65	6	RES SMD 0805: 27k / 1% / 0,125W	R550, R551, R558, R559, R562, R563		
66	5	RES SMD 0805: 33k / 1% / 0,125W	R1.R2, R2.R2, R3.R2, R4.R2, R661		
67	1	RES SMD 0805: 39k / 1% / 0,125W	R573		
68	1	RES SMD 0805: 47k / 1% / 0,125W	R675		
69	3	RES SMD 0805: 56k / 1% / 0,125W	R552, R560, R564		
70	1	RES SMD 0805: 68k / 1% / 0,125W	R202		
71	1	RES SMD 0805: 220k / 1% / 0,125W	R612		
72	6	RES SMD 0805: 10k / 0,1% / 0,125W	R553, R557, R565, R569, R600, R608		
73	1	RES SMD 0805: 14k / 0,1% / 0,125W	R668		
74	9	RES SMD 0805: 0R15 / 1% / 0,125W	R1.R1, R1.R10, R2.R1, R2.R10, R3.R1, R3.R10, R4.R1, R4.R10, R205		
75	2	RES SMD 1206: 22R / 1% / 0,25W	R658, R664		
76	1	RES SMD 1206: 82R / 1% / 0,25W	R404		
77	3	RES SMD 1206: 1k0 / 1% / 0,25W	R681, R682, R683		
78	1	RES SMD 1206: 2k2 / 1% / 0,25W	R679		
79	1	RES SMD Melf: 2R2 / 1% / 0,4W	R673		
80	2	RES THT: PO591-0 5T 56K	R400, R401	PO591-0 5T 56K	VITROHM
81	3	VARISTOR: 510V RMS 20MM MOV- 20D821K	R453, R454, R455	MOV-20D821K	Bourns
82	2	RES NTC: SL32 5R020	R402, R403	SL32 5R020	Ametherm
83	1	RES VAR: 1k / 250mW / SMD	R554	23BR1KLFTR	BI Technologies
84	5	RES SMD 2512: 68k / 1% / 1W	R350, R351, R352, R353, R354		
85	3	RES SMD 2512: 0R0 / 1W	R12, R13, R14		
86	2	RES SMD 2512: 8R2 / 1% / 3W	R684, R685	35228R2JT	TE Connectivity
87	2	RES SMD 2512: 10k / 1% / 1W	R651, R655		
88	3	RES SMD 2512: 220k / 1% / 2W	R450, R451, R452		
89	3	RES SMD 2512: 0R002 / 1% / 3W	CU.R302, CV.R302, CW.R302	CRE2512-FZ- R002E-3	Bourns
90	4	RES SMD 0603: 8k2 / 1% / 0,1W	R1.R5, R2.R5, R3.R5, R4.R5		
91	22	RES SMD 0603: 10k / 1% / 0,1W	R1.R3, R1.R7, R1.R8, R1.R9, R2.R3, R2.R7, R2.R8, R2.R9, R3.R3, R3.R7, R3.R8, R3.R9, R4.R3, R4.R7, R4.R8,		

Bill of material

No.	Qty.	Part description	Designator	Part number	Manufacturer
			R4.R9, R20, R21, R22, R23, R24, R25		
92	4	RES SMD 0603: 20k / 1% / 0,1W	R1.R6, R2.R6, R3.R6, R4.R6		
93	3	RES SMD 2010: 10M / 1% / 0,75W	R650, R654, R659		
94	3	RES SMD 2010: 3M3 / 5% / 0,75W	R656, R660, R665		
95	1	RES SMD: 0R003 / 1% / 5W	R50	CSS2H-3920K- 3L00F	Bourns
96	1	CAP CER 0805: 47p / 50V / X7R	C100		
97	8	CAP CER 0805: 100p / 50V / X7R	C206, C666, U.C150, U.C155, V.C150, V.C155, W.C150, W.C155		
98	5	CAP CER 0805: 220p / 50V / X7R	C63, C550, C552, C556, C558		
99	6	CAP CER 0805: 470p / 50V / X7R	C600, C601, C602, C606, C607, C608		
100	3	CAP CER 0805: 680p / 50V / X7R	C551, C555, C557		
101	4	CAP CER 0805: 1n / 50V / X7R	C207, C665, C671, C678		
102	1	CAP CER 0805: 2n2 / 50V / X7R	C561		
103	4	CAP CER 0805: 4n7 / 50V / X7R	C354, CU.C304, CV.C304, CW.C304		
104	1	CAP CER 0805: 6n8 / 50V / X7R	C676		
105	4	CAP CER 0805: 10n / 50V / X7R	C500, C501, C502, C503		
106	30	CAP CER 0805: 100n / 50V / X7R	C20, C60, C61, C200, C351, C353, C563, C564, C565, C603, C604, C605, C610, C611, C612, C613, C662, C670, CU.C301, CU.C303, CV.C301, CV.C303, CW.C301, CW.C303, U.C152, U.C157, V.C152, V.C157, W.C152, W.C157		
107	1	CAP CER 0805: 680n / 50V / X7R	C672		
108	1	CAP CER 0805: 1u / 50V / X7R	C62		
109	2	CAP CER 0805: 2u2 / 50V / X7R	C554, C559		
110	57	CAP CER 0805: 4u7 / 35V / X5R	C64, C201, C202, C203, C204, C205, C350, C352, C405, C406, C562, C609, C654, C658, C661, C668, C669, C674, C675, CU.C300, CU.C302, CV.C300, CV.C302, CW.C300, CW.C302,		

Bill of material

No.	Qty.	Part description	Designator	Part number	Manufacturer
			R1.C1, R1.C2, R1.C3, R1.C4, R1.C5, R2.C1, R2.C2, R2.C3, R2.C4, R2.C5, R3.C1, R3.C2, R3.C3, R3.C4, R3.C5, R4.C1, R4.C2, R4.C3, R4.C4, R4.C5, U.C151, U.C153, U.C156, U.C158, V.C151, V.C153, V.C156, V.C158, W.C151, W.C153, W.C156, W.C158		
111	1	CAP CER 0805: 18p / 50V / X7R	C659		
112	2	CAP CER 1206: 470p / 200V / X7R	C651, C655		
113	6	CAP CER: VY1472M61Y5UC63V0	CY450, CY451, CY452, CY453, CY454, CY455	VY1472M61Y5UC 63V0	Vishay
114	4	CAP CER: 47n / 1,5kV / X7R	C50, C51, C54, C55	2220SC473KAT1A	AVX
115	1	CAP FILM: B32021A3102M	C664	B32021A3102M28 9	TDK
116	1	CAP FILM: B32021A3222M189	C650	B32021A3222M18 9	TDK
117	6	CAP FILM: 1u / 480V / X1	CX450, CX451, CX452, CX453, CX454, CX455	F339X151048KKI 2B0	Vishay
118	1	CAP FILM: MKP 20u 800VDC DC- Link 4Pin	C52	DCP4L052007GD 4K*SD	WIMA
119	2	CAP FILM: B32674D1105K000	C402, C677	B32674D1105K00 0	TDK
120	1	CAP ALUM: NACZ100M50V6,3X6,3	C660	NACZ100M50V6.3 X6.3	NIC Components
121	6	CAP ALUM: 16SVPF180M	C652, C653, C656, C657, C667, C673	16SVPF180M	Panasonic
122	4	CAP ALUM: 1200u/400V	C400, C401, C403, C404	B43630A9128M00 0	TDK
123	16	CAP CER 0603: 2u2 / 16V / X5R	R1.C8, R1.C9, R1.C10, R1.C11, R2.C8, R2.C9, R2.C10, R2.C11, R3.C8, R3.C9, R3.C10, R3.C11, R4.C8, R4.C9, R4.C10, R4.C11		
124	1	IND CM MODE: 744227	L200	744227	Würth Elektronik
125	2	IND CM MODE: 744221	L650, L651	744221	Würth Elektronik
126	1	IND CM MODE: T60405-S6123- X317	L452	T60405-S6123- X317	VACUUMSCHMEL ZE
127	2	TRANSFORMER: T60403-F5046- X007	TR200, TR201	T60403-F5046- X007	VACUUMSCHMEL ZE

Bill of material

No.	Qty.	Part description	Designator	Part number	Manufacturer
128	3	FUSE: D6,3x32mm / 16A	F400, F401, F402		
129	6	FUSE CLIP: 6,3mm	X401, X402, X403, X404, X405, X406	80.400.001	Schurter
130	1	RELAY: RTS3L012	K400	1-1415898-9	TE Connectivity / Schrack
131	1	CON MULTIPOLE: 2x16	X10	09 27 232 6801	Harting
132	5	CON: pinheader 2x3	R1.X8, R2.X8, R3.X8, R4.X8, X11	826632-3	TE Connectivity
133	1	CON: pin header 2x8	X7	TSM-108-01-T-DV	Samtec
134	3	CON TERM BLOCK: MKDS 3/ 4- 5,08	X1, X2, X6	1712805	PHOENIX CONTACT
135	1	CON TERM BLOCK: SPTA 1,5/ 4- 3,81	X4	1751493	PHOENIX CONTACT
136	2	FAN: EB40201S2-0000-999	FAN1, FAN2	EB40201S2-0000- 999	Sunon
137	1	TRANSFORMER: Flyback	T650	ÜP615694	Pikatron GmbH
138	1	HEATSINK: FISCHER_SK 85/150	HS1	SK 85/150 SA	Fischer Elektronik

Measurements

6 Measurements

The following chapter provides some typical measurements made with the Eval-M5-E1B1245N-SiC evaluation board. The board is supplied by a 400 V grid and is connected at the output to a symmetrical RL-load illustrated in Figure 23.

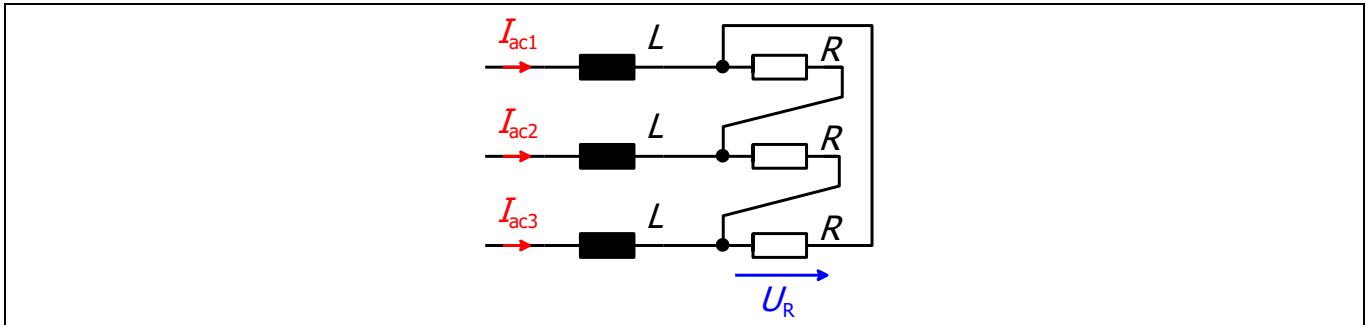

Figure 23 Test load

The value of the inductance is 1.5 mH and the value of the resistor is 23 Ohm. With a nominal output current of 16 A_{RMS}, the output power is about 5.9 kW. The switching frequency was set to 18 kHz. The following screenshot shows the related measurement.

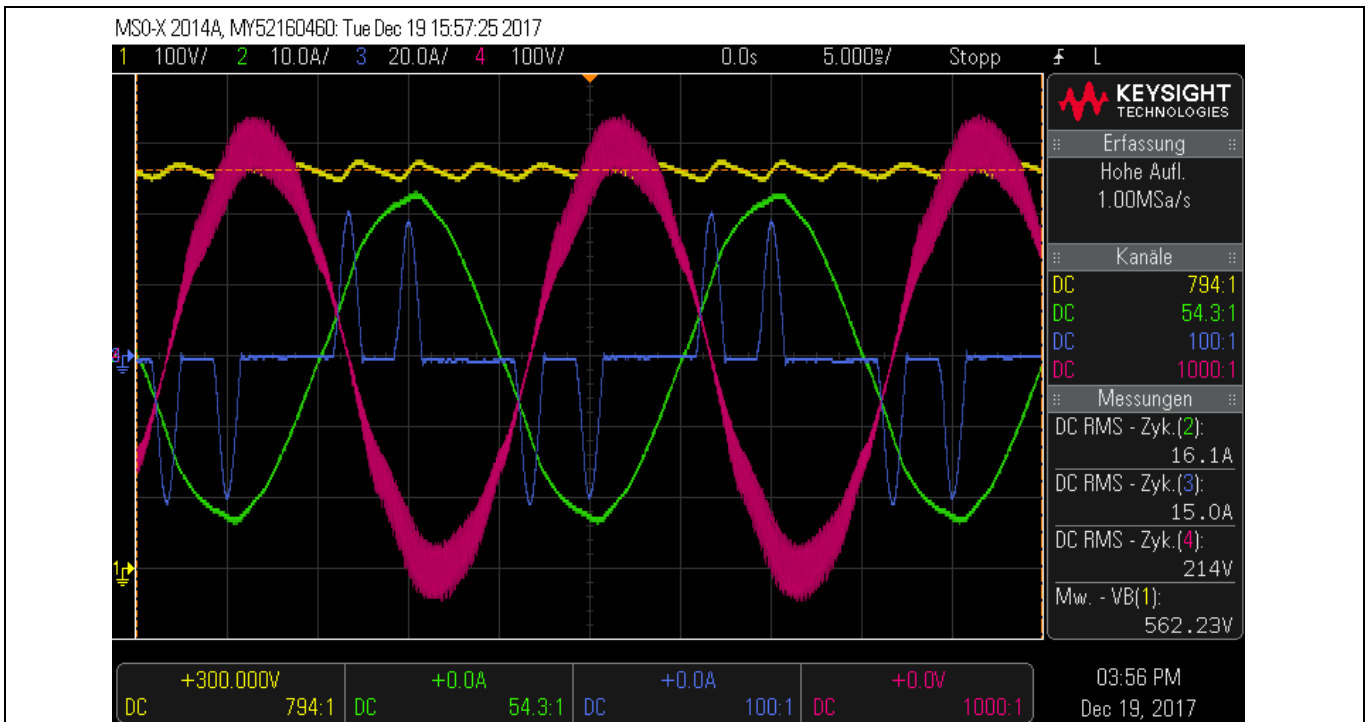

Figure 24 Measurement waveforms with test load

The output phase current (green) and the resistor voltage (red) are almost sinusoidal, whereas the input line current (blue) shows the typical waveform of a capacitor charging current. Due to its high crest factor, the rms-value is as high as 15 A, even at only 6 kW input power. The yellow signal shows the rectified DC-bus voltage of about 562 V.

Measurements

6.1 Thermal measurements

After the board was powered for over an hour at the above-mentioned load conditions, the following thermal images were made. At the same time, the NTC temperature was measured with $T_{Modul} \approx 92\text{ °C}$.



Figure 25 Thermal image of evaluation board at 18 kHz switching frequency

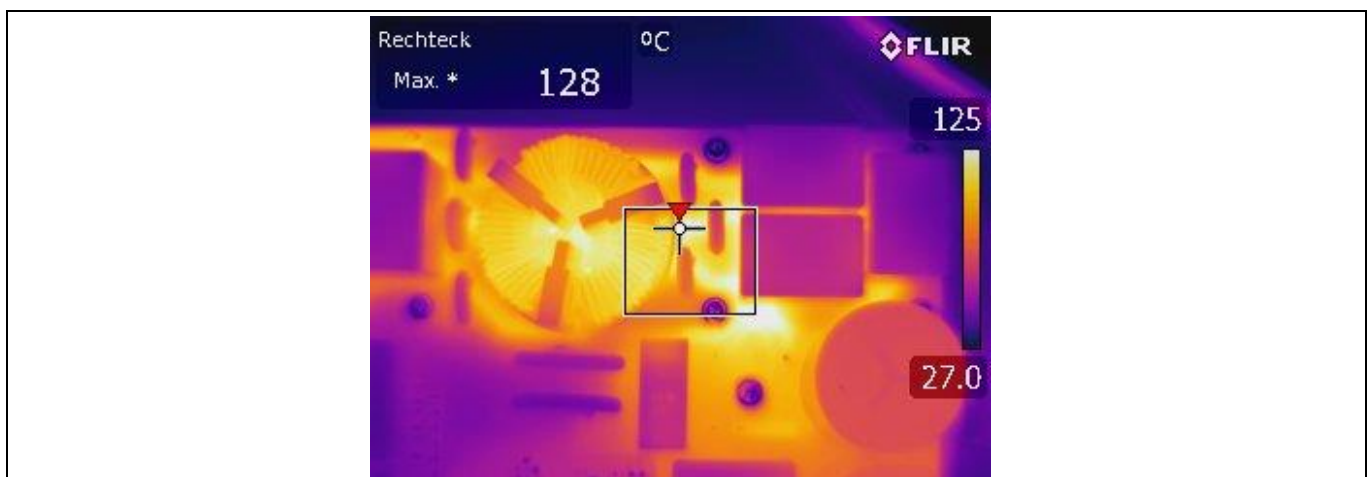

Figure 26 Thermal image of input area

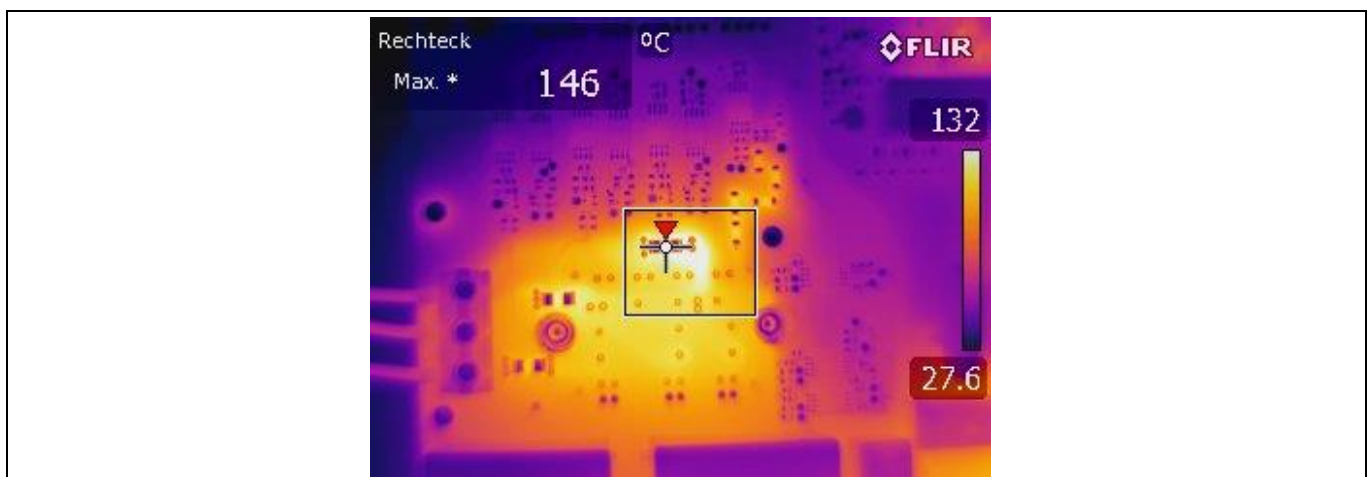

Figure 27 Thermal image of power module area

Measurements

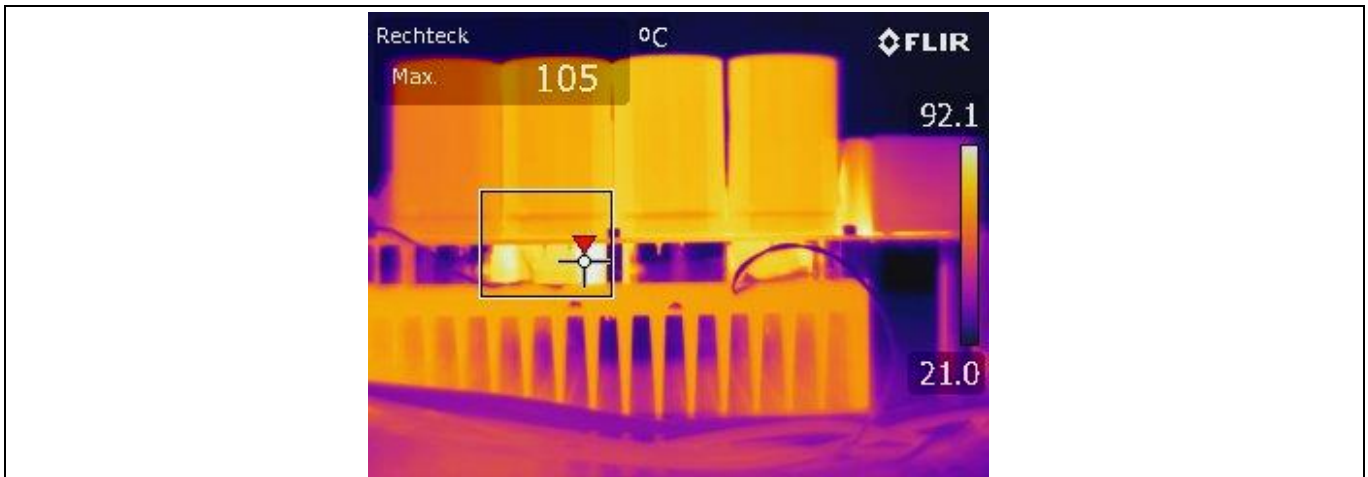

Figure 28 Thermal image of power module and rectifier (side view)

To evaluate the thermal behavior of the Eval-M5-E1B1245N-SiC evaluation board at 100 kHz switching frequency, the current was reduced until the same module temperature of $T_{\text{Modul}} \approx 92\text{ °C}$ was measured. This point was reached at 8 ARMS output current. Figure 29 shows the thermal image at this operating point.



Figure 29 Thermal image of evaluation board at 100 kHz switching frequency

6.2 EMI measurements

The conducted EMI emission of the evaluation board was measured according DIN EN 55011, connected to the grid via a 32 A – LISN. In Figure 30, the emission and the threshold limits for industrial use (DIN EN 55011, class A, group 1, $\leq 20\text{ kVA}$) can be found. As one can see, the limits have almost been reached.

Measurements

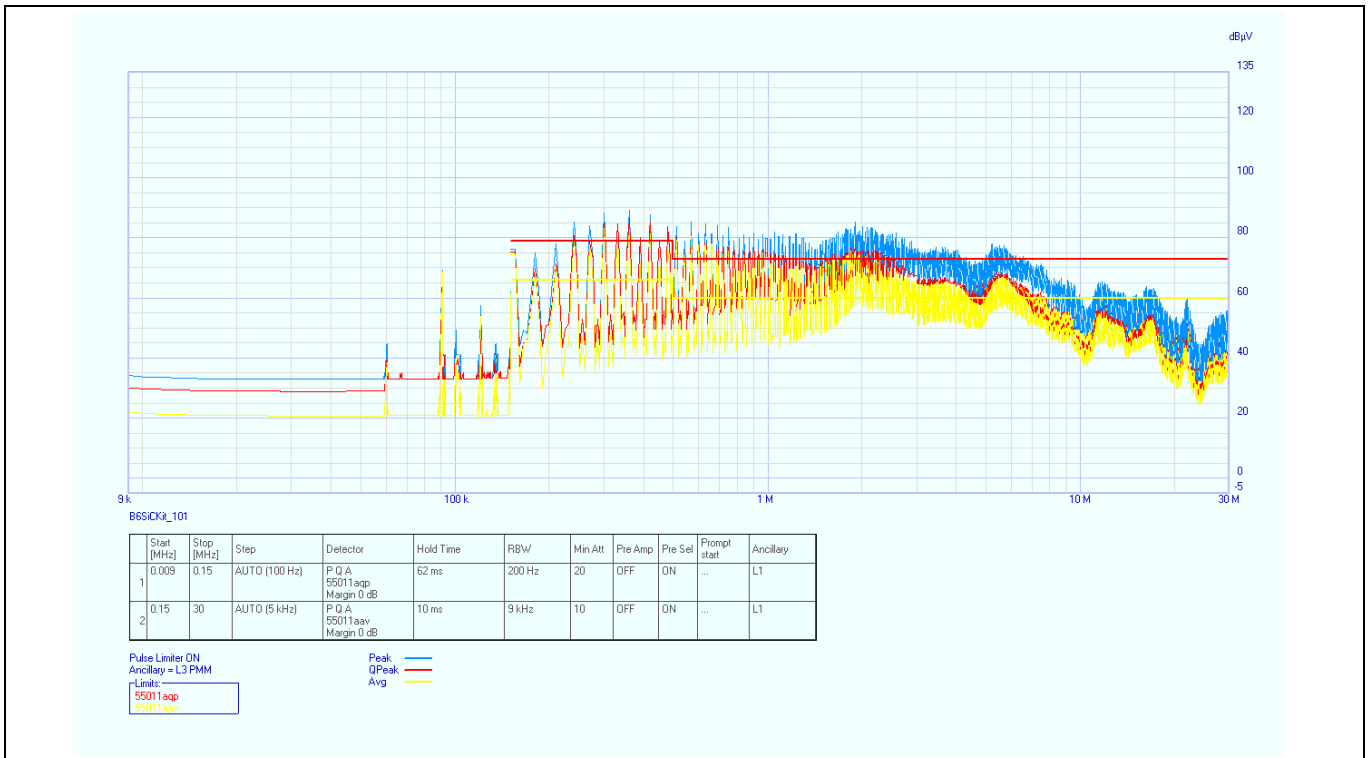

Figure 30 Conducted EMI emission

The emissions can be damped under the limits by using a small external common mode choke. The next figure shows the result using a Vacuumschmelze W 424-53 choke with three turns.

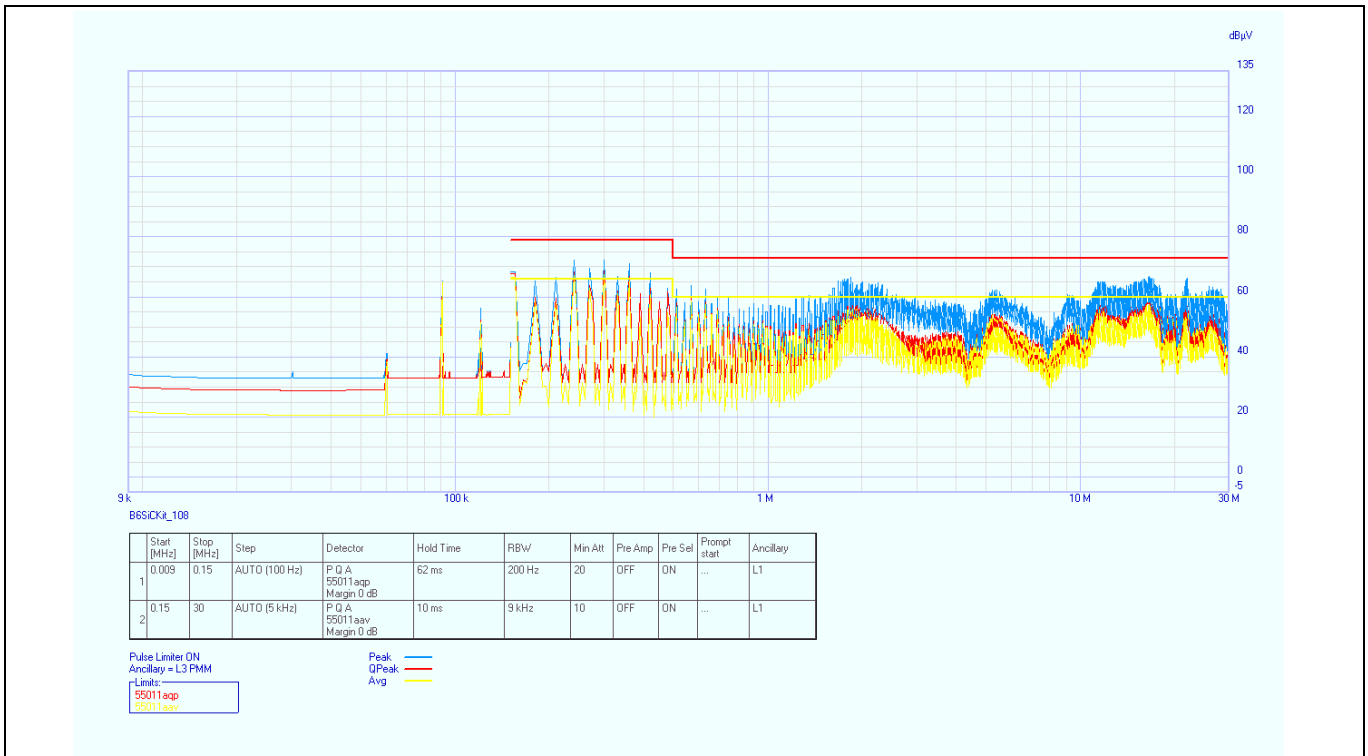

Figure 31 Conducted EMI emission with small external common mode choke

References

7 References

- [1] [Datasheet Infineon FS45MR12W1M1 B11](#)
- [2] [Datasheet of Infineon Eice-Driver 1EDI20H12AH](#)
- [3] [Datasheet of Texas Instruments isolated \$\Delta\Sigma\$ -Modulator AMC1303M2520](#)

References

Revision History

Major changes since the last revision

Page or Reference	Description of change
1.0	Initial version

Trademarks

All referenced product or service names and trademarks are the property of their respective owners.

Edition <yyyy-mm-dd>

Published by

Infineon Technologies AG

81726 Munich, Germany

© 2019 Infineon Technologies AG.

All Rights Reserved.

Do you have a question about this document?

Email: erratum@infineon.com

Document reference

AppNote Number - AN2019-25

IMPORTANT NOTICE

The information contained in this application note is given as a hint for the implementation of the product only and shall in no event be regarded as a description or warranty of a certain functionality, condition or quality of the product. Before implementation of the product, the recipient of this application note must verify any function and other technical information given herein in the real application. Infineon Technologies hereby disclaims any and all warranties and liabilities of any kind (including without limitation warranties of non-infringement of intellectual property rights of any third party) with respect to any and all information given in this application note.

The data contained in this document is exclusively intended for technically trained staff. It is the responsibility of customer's technical departments to evaluate the suitability of the product for the intended application and the completeness of the product information given in this document with respect to such application.

For further information on the product, technology delivery terms and conditions and prices please contact your nearest Infineon Technologies office (www.infineon.com).

WARNINGS

Due to technical requirements products may contain dangerous substances. For information on the types in question please contact your nearest Infineon Technologies office.

Except as otherwise explicitly approved by Infineon Technologies in a written document signed by authorized representatives of Infineon Technologies, Infineon Technologies' products may not be used in any applications where a failure of the product or any consequences of the use thereof can reasonably be expected to result in personal injury.

Looking for pricing, stock, or lifecycle information?

Click below to explore more details on WIN SOURCE:

- ⊖ [View EVALM5E1B1245NSICTOBO1 on WIN SOURCE](#)
- ⊖ [Infineon Technologies Information](#)

Optimize Your Supply Chain with WIN SOURCE Solutions

- ✓ Global Sourcing Solution
- ✓ Obsolete Management
- ✓ Cost Control Management
- ✓ Shortage Management
- ✓ Alternative Solution
- ✓ Excess Inventory Management