



**THE DATASHEET OF
MAX33046ESHLD#**



Evaluates: MAX33045E/MAX33046E

MAX33046E Evaluation Kit

General Description

The MAX33046E is a fully assembled and tested printed circuit board (PCB) that demonstrates the functionality of the MAX33046E half-duplex RS-485 transceiver with $\pm 25V$ fault protection, extended $-7V$ to $+12V$ common-mode range, and $\pm 40kV$ ESD Human Body Model (HBM) for A/B data lines. The shield features a digital isolator which is used as a level translator between the RS-485 transceiver and the controller interface.

Features

- Easy Evaluation of the MAX33046E/MAX33045E
- I/O Interface Compatibility from 1.71V to 5.5V
- Proven PCB Layout
- Arduino®/Arm® Mbed™ Platform Compatible
- Fully Assembled and Tested

Quick Start

Required Equipment

- MAX33046E Shield
- 3.3V (or 5V), 500mA DC power supply
- Signal/function generator that can generate a 10MHz square wave signal
- Oscilloscope

[Ordering Information](#) appears at end of data sheet.

EV Kit Photo with Jumpers and Test Point Positions

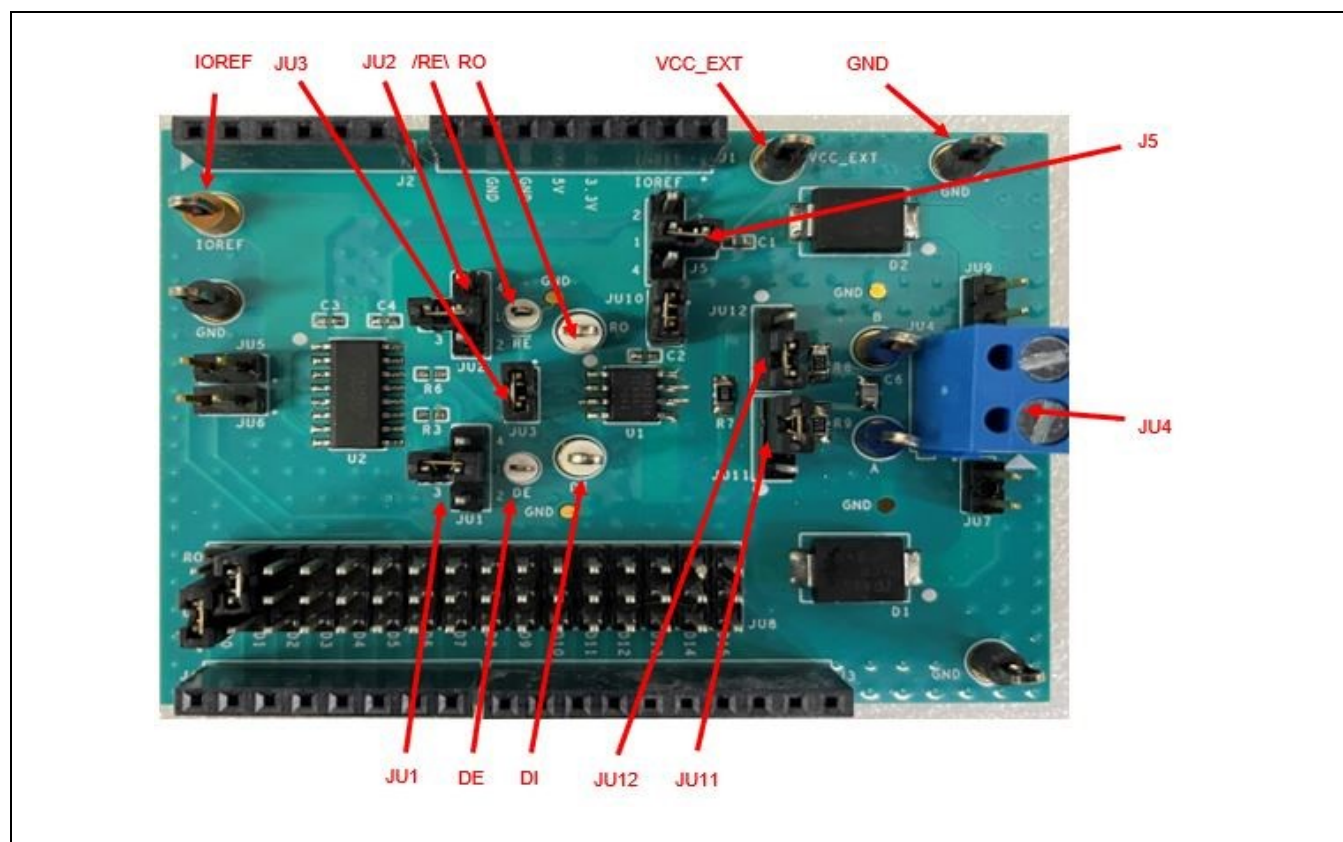

Procedure

1. Place the MAX33046E Shield on a nonconductive surface to ensure that nothing on the PCB gets shorted to the workspace.
2. Set all jumpers to their default position as shown in [Table 1](#).
3. With the 3.3V (or 5V) power supply disabled, connect the positive terminal to VCC_EXT and IOREF test points. Connect the negative terminal to a GND test point.
4. Connect the positive terminal of the function generator to DI and the negative terminal to any GND test point on the shield.
5. Set the function generator to output a 10MHz square wave between 0V and 3.3V (or 5V), then enable function generator output.
6. Turn on the 3.3V (or 5V) DC power supply.
7. Connect an oscilloscope probe to DI and verify that the output signal at RO matches the DI input signal (DI).

Detailed Description of Hardware

The MAX33046E Shield is a fully assembled and tested circuit board for evaluating the MAX33046E fault-protected half-duplex RS-485 transceiver (U1) with $\pm 25V$ of fault protection. The Shield is designed to evaluate MAX33046E alone or in a RS-485 system. The MAX33046E Shield can also enable the Arduino or Mbed platform to communicate on a RS-485 bus. The MAX14931 digital isolator is used as a level translator with a 1.71V to 5.5V supply range. Remove the 0Ω resistor R6 to apply the transmitter input signal directly on the DI test point. Likewise, remove the 0Ω resistor R3 to measure the receiver output signal directly on the RO test point.

The shield also features an option for TVS diodes (D1 and D2) that can be connected to the A and B lines using JU7 and JU9 respectively if external protection is desired beyond the device's built-in protection.

Powering the Board

The MAX33046E Shield requires two power supplies—one 3V to 5.5V supply for the MAX33046E (U1) transceiver applied at the VCC_EXT test point and one 1.71V to 5.5V supply for the microcontroller domain applied at the IOREF test point. When the shield board is used with an Arduino/Mbed board, the power supply for U1 can also come from the Arduino/Mbed board's 3.3V or 5V rail. Place the shunt on 1-3 position of J5 to connect V_{CC} to VCC_EXT pin. Place the shunt of J5 on the 1-2 position or the 1-4 position to connect the V_{CC} of U1 to the Arduino/Mbed board's 3.3V or 5V supply rail. In this scenario, IOREF is directly taken from the Arduino/Mbed header.

On-Board Termination

A properly terminated RS-485 bus is terminated at each end with the characteristic impedance of the cable. For CAT5 or CAT6 cables, this is typically 120 Ω on each end for a 54 Ω load on the RS-485 driver. The MAX33046E Shield features a selectable 54 Ω or 120 Ω load circuit between the A and B driver outputs. If the board is evaluated in a system and connected at the end of the cable, select 120 Ω termination. The termination resistors on the MAX33046E Shield should be changed to 54 Ω with a 100pF load to simulate a complete system load during evaluation.

DI and RO Configuration

Digital channels for DI and RO are selected through JU8, which consists of three columns and 16 rows. The columns labeled DI and RO are connected to MAX33046E through the digital isolator (MAX14931FASE+ (U2)). The middle column contains the digital I/O pins D0 to D15 from the Arduino/Mbed header. This provides flexibility for the user to select different resources on the microcontroller to transmit and receive signals to and from the RS-485 transceiver. [Table 2](#) shows the list of JU8 jumper options. For single-channel performance verification, driver input can connect to test point DI and probe to test point RO directly.

Flexible Interface Options

The MAX33046E Shield allows multiple points of connection to the MAX33046E transceiver. The shield board can be placed on an Arduino/Mbed compatible board to connect all the digital pins (DI, DE, RO, POL) through the J3 and J4 headers. These signals can also be connected directly at their respective test points on the board, bypassing the digital isolator (U2). The A/B signals are connected to a terminal block (JU4) to easily connect to a twisted pair cable. Alternately, the A/B test points may be used.

PCB Layout for Thermal Dissipation

PCB layout can affect the performance of the transceiver in conditions with a high common-mode voltage at high ambient temperatures. The layout of the MAX33046E Shield is designed to maximize thermal performance in such cases. The GND pad is connected to a large copper plane on the top layer, with vias throughout the plane connecting to the GND plane on the bottom layer. A thick trace from the V_{CC} pad to JU10 allows for greater heat dissipation at the V_{CC} pin.

Table 1. Jumper Settings

JUMPER	SHUNT POSITION	DESCRIPTION
JU1	1-2	DE is connected to level shifter output
	1-3*	DE is shorted to V_{CC}
	1-4	DE is shorted to GND
	Open	DE is open
JU2	1-2	\overline{RE} is connected to level shifter output
	1-3	\overline{RE} is shorted to V_{CC}
	1-4*	\overline{RE} is shorted to GND
	Open	\overline{RE} is open
JU3	1	\overline{RE} input when JU2 is open
	2	DE input when JU2 is open
JU4	1	Driver output A
	2	Driver output B
JU5	1-2*	Connects \overline{RE} to D6 of J4
	Open	Disconnects \overline{RE} from D6 of J4
JU6	1-2*	Connects DE to D7 of J4
	Open	Disconnects DE from D7 of J4
JU7	1-2	TVS Diode connected to A
	Open*	TVS Diode disconnected from A
JU9	1-2	TVS Diode connected to B
	Open*	TVS Diode disconnected from B
JU10	1-2*	Connects V_{CC} pin of U1 to supply rail
	Open	Disconnects V_{CC} pin of U1 from supply rail
JU11 & JU12	1-2	Connects 120 Ω between A and B
	2-3*	Connects 54 Ω between A and B
	Open	No load is connected between A and B
J5	1-2	V_{CC} connects to onboard 3.3V
	1-3*	V_{CC} connects to V_{CC_EXT}
	1-4	V_{CC} connects to on-board 5.0V
	Open	\overline{RE} is open

* Indicates default jumper state.

Table 2. DI and RO Jumper Settings

JUMPER	SHUNT POSITION	DESCRIPTION
JU8	1-2*	Connects DI to D0
	4-5	Connects DI to D1
	7-8	Connects DI to D2
	10-11	Connects DI to D3
	13-14	Connects DI to D4
	16-17	Connects DI to D5
	19-20	Connects DI to D6
	22-23	Connects DI to D7
	25-26	Connects DI to D8
	28-29	Connects DI to D9
	31-32	Connects DI to D10
	34-35	Connects DI to D11
	37-38	Connects DI to D12
	40-41	Connects DI to D13
	43-44	Connects DI to D14
	46-47	Connects DI to D15
	2-3	Connects RO to D0
	5-6*	Connects RO to D1
	8-9	Connects RO to D2
	11-12	Connects RO to D3
	14-15	Connects RO to D4
	17-18	Connects RO to D5
	20-21	Connects RO to D6
	23-24	Connects RO to D7
	26-27	Connects RO to D8
	29-30	Connects RO to D9
	32-33	Connects RO to D10
	35-36	Connects RO to D11
	38-39	Connects RO to D12
	41-42	Connects RO to D13
	44-45	Connects RO to D14
	47-48	Connects RO to D15

* Indicates default jumper state.

Ordering Information

PART	TYPE
MAX33046ESHLD#	EV Kit

#Denotes RoHS-compliant.

MAX33046E EV Kit Bill of Materials

ITEM	QTY	REF DES	MFG PART #	MANUFACTURER	VALUE	DESCRIPTION
1	2	A, B	5127	KEYSTONE	N/A	TEST POINT; PIN DIA=0.125IN; TOTAL LENGTH=0.445IN; BOARD HOLE=0.063IN; BLUE; PHOSPHOR BRONZE WIRE SILVER PLATE FINISH
2	1	C1	GRM155R60J106 ME44; GRM155R60J106 ME47; C1005X5R0J106M050BC	MURATA;MURATA;TDK;SAMSUNG ELECTRONICS;KEMET	10UF	CAPACITOR; SMT (0402); CERAMIC CHIP; 10UF; 6.3V; TOL=20%; TG=-55 DEGC TO +85 DEGC; TC=X5R
3	3	C2-C4	C0402C104J4RAC ;GCM155R71C104JA55	KEMET;MURATA	0.1UF	CAPACITOR; SMT (0402); CERAMIC CHIP; 0.1UF; 16V; TOL=5%; MODEL=; TG=-55 DEGC TO +125 DEGC; TC=X7R
4	1	C6	08051A500FAT2A	AVX	50PF	CAP; SMT (0805); 50PF; 1%; 100V; C0G; CERAMIC CHIP
5	2	D1, D2	SM15T30CA	ST MICROELECTRONICS	25.6V	DIODE; TVS; SMC (DO-214AB); VRM=25.6V; IPP=36A
6	2	DE, RE	5002	KEYSTONE	N/A	TEST POINT; PIN DIA=0.1IN; TOTAL LENGTH=0.3IN; BOARD HOLE=0.04IN; WHITE; PHOSPHOR BRONZE WIRE SILVER
7	2	DI, RO	5012	KEYSTONE	N/A	TEST POINT; PIN DIA=0.125IN; TOTAL LENGTH=0.445IN; BOARD HOLE=0.063IN; WHITE; PHOSPHOR BRONZE WIRE SILVER PLATE FINISH
8	1	IOR EF	5125	KEYSTONE	N/A	TEST POINT; PIN DIA=0.125IN; TOTAL LENGTH=0.445IN; BOARD HOLE=0.063IN; BROWN; PHOSPHOR BRONZE WIRE SILVER PLATE FINISH
9	2	J1, J4	SSQ-108-24-G-S	SAMTEC	SSQ-108-24-G-S	CONNECTOR; FEMALE; THROUGH HOLE; .025INCH SQ POST SOCKET; STRAIGHT; 8PINS ;NOTE:PURCHASE DIRECT FROM THE MANUFACTURER

ITEM	QTY	REF DES	MFG PART #	MANUFACTURER	VALUE	DESCRIPTION
10	1	J2	SSQ-106-24-G-S	SAMTEC	SSQ-106-24-G-S	CONNECTOR; FEMALE; THROUGH HOLE; .025INCH SQ POST SOCKET; STRAIGHT; 6PINS ;NOTE:PURCHASE DIRECT FROM THE MANUFACTURER
11	1	J3	SSQ-110-24-G-S	SAMTEC	SSQ-110-24-G-S	CONNECTOR; FEMALE; THROUGH HOLE; .025INCH SQ POST SOCKET; STRAIGHT; 10PINS ;NOTE:PURCHASE DIRECT FROM THE MANUFACTURER
12	3	J5, JU1, JU2	PEC04SAAN	SULLINS ELECTRONICS CORP.	PEC04SAAN	CONNECTOR; MALE; THROUGH HOLE; BREAKAWAY; STRAIGHT; 4PINS
13	6	JU3, JU5- JU7, JU9, JU10	PCC02SAAN	SULLINS	PCC02SAAN	CONNECTOR; MALE; THROUGH HOLE; BREAKAWAY; STRAIGHT THROUGH; 2PINS; -65 DEGC TO +125 DEGC
14	1	JU4	OSTTA024163	ON-SHORE TECHNOLOGY INC.	OSTTA024163	CONNECTOR; FEMALE; THROUGH HOLE; 5.08MM TERM BLOCK CONNECTOR; STRAIGHT; 2PINS; -30 DEGC TO +105 DEGC
15	1	JU8	TSW-116-07-T-T	SAMTEC	TSW-116-07-T-T	CONNECTOR; MALE; THROUGH HOLE; 0.025IN SQ POST HEADER; STRAIGHT; 48PINS
16	2	JU11, JU12	PEC03SAAN	SULLINS	PEC03SAAN	CONNECTOR; MALE; THROUGH HOLE; BREAKAWAY; STRAIGHT; 3PINS
17	2	R3, R6	ERJ-2GE0R00	PANASONIC	0	RESISTOR; 0402; 0 OHM; 0%; JUMPER; 0.10W; THICK FILM
18	1	R7	CRCW0805120RFK	VISHAY DALE	120	RESISTOR; 0805; 120 OHM; 1%; 100PPM; 0.125W; THICK FILM
19	2	R8, R9	ERA-6AHD270	PANASONIC	27	RES; SMT (0805); 27; 0.5%; +/- 50PPM/DEGC; 0.125W
20	8	SU1, SU2, SU5, SU8- SU12	2SN-BK-G	SAMTEC	2SN-BK-G	TEST POINT; JUMPER; STR; TOTAL LENGTH=0.175IN; BLACK; INSULATION=PBT;PHOSPHOR BRONZE CONTACT=GOLD PLATED

ITEM	QTY	REF DES	MFG PART #	MANUFACTURER	VALUE	DESCRIPTION
21	3	TP18 - TP20	5011	KEYSTONE	N/A	TEST POINT; PIN DIA=0.125IN; TOTAL LENGTH=0.445IN; BOARD HOLE=0.063IN; BLACK; PHOSPHOR BRONZE WIRE SILVER PLATE FINISH
22	1	U1	MAX33046EASA+	MAXIM	MAX33046EASA+	EVKIT PART - IC; MAX33046EASA+; HALF-DUPLEX RS-485/422 TRANSCEIVER; PACKAGE OUTLINE DRAWING: 21-0041; LAND PATTERN DRAWING: 90-0096; NSOIC8
23	1	U2	MAX14931CASE+	MAXIM	MAX14931CASE+	IC; DISO; 3/1 CHANNEL; 150MBPS; DEFAULT LOW; 2.75KVRMS DIGITAL ISOLATOR; NSOIC16
24	1	VCC _EX T	5010	KEYSTONE	N/A	TEST POINT; PIN DIA=0.125IN; TOTAL LENGTH=0.445IN; BOARD HOLE=0.063IN; RED; PHOSPHOR BRONZE WIRE SIL
25	1	PCB	MAX33046ESHIELD	MAXIM	PCB	PCB:MAX33046ESHIELD

**If MAX33045E needs to be evaluated, change U1 IC to MAX33045E.*

MAX33046E EV Kit PCB Layout

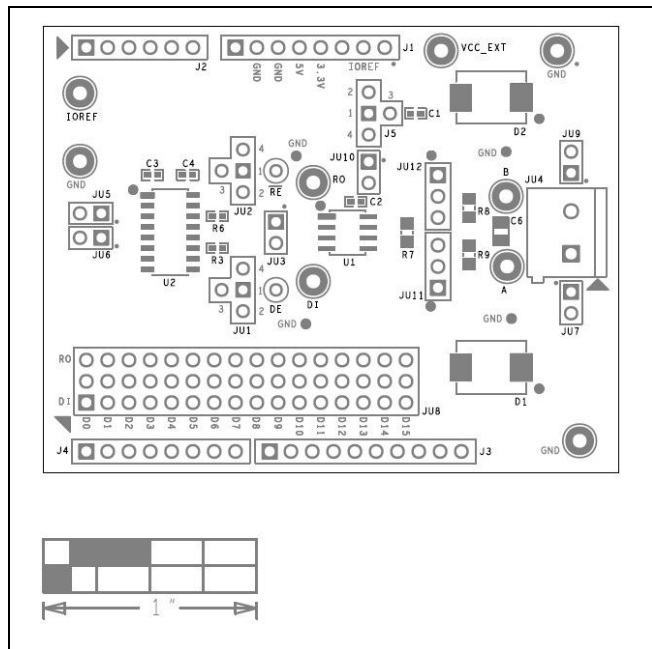

MAX33046E EV Kit PCB Layout—Top Silkscreen

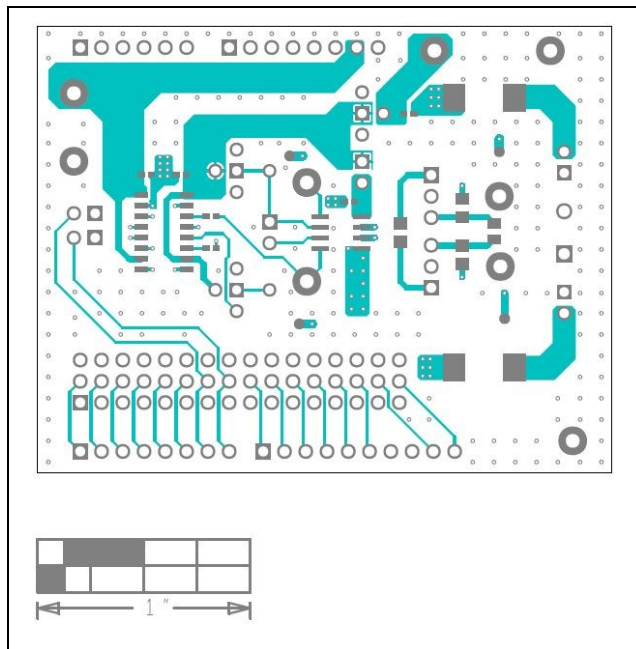

MAX33046E EV Kit PCB Layout—Top Layer

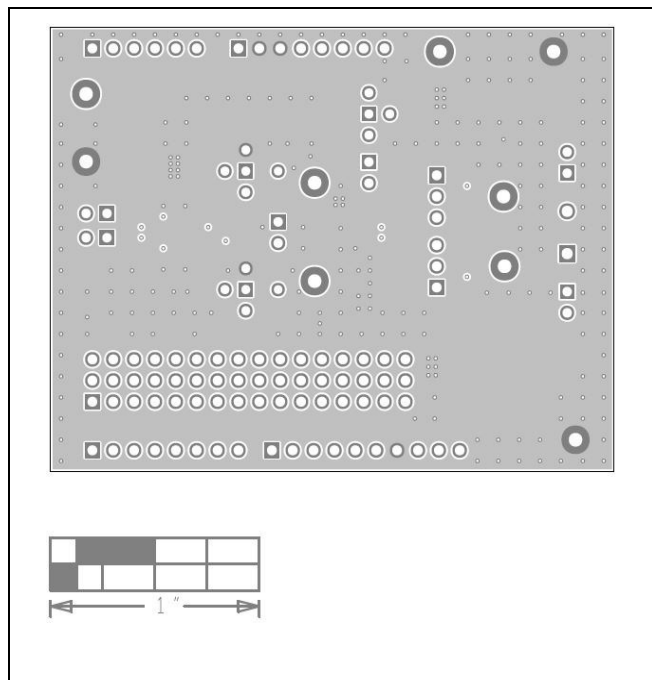

MAX33046E EV Kit PCB Layout—Second Layer

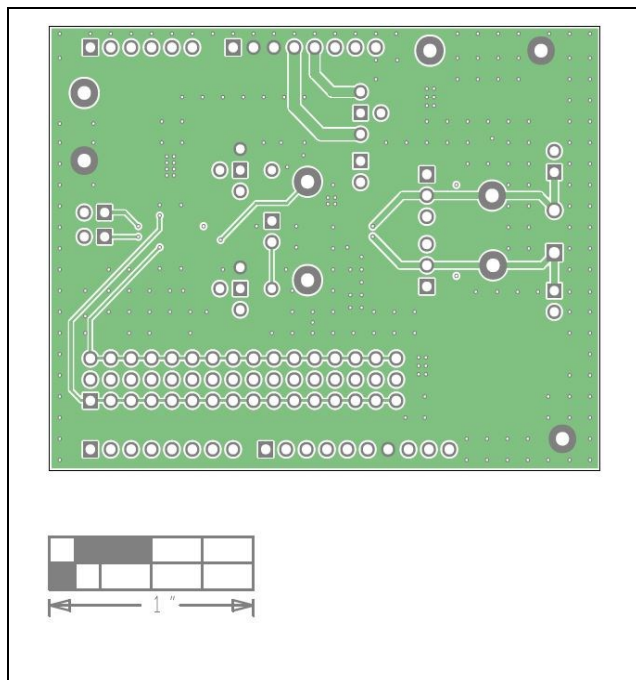

MAX33046E EV Kit PCB Layout—Third Layer

MAX33046 EV Kit PCB Layouts (continued)

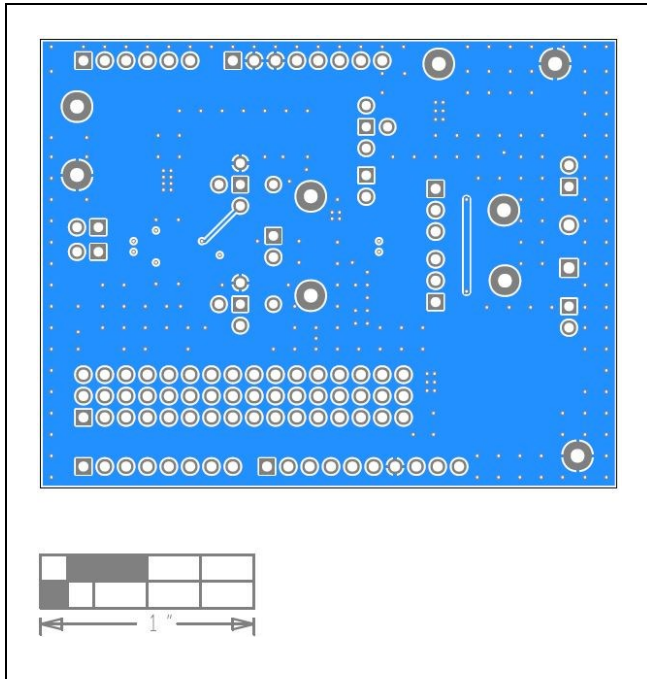

MAX33046E EV Kit PCB Layout—Bottom Layer

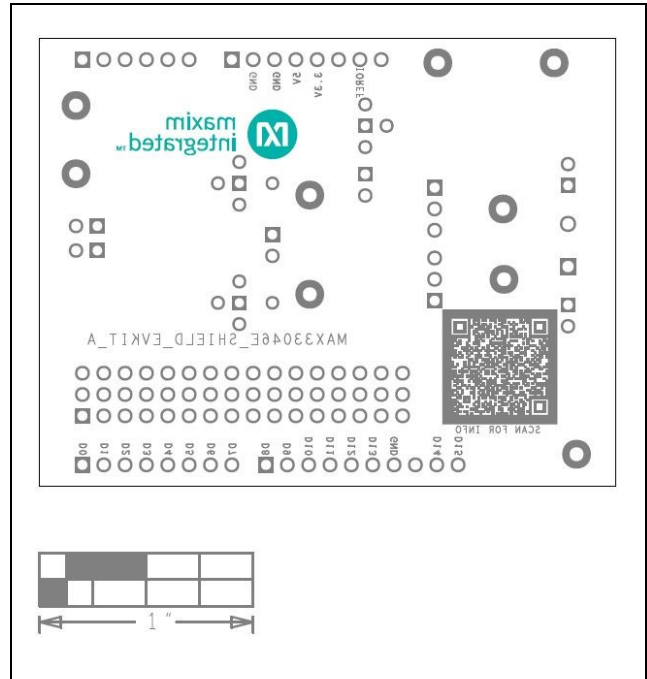

MAX33046E EV Kit PCB Layout—Bottom Silkscreen

Revision History

REVISION NUMBER	REVISION DATE	DESCRIPTION	PAGES CHANGED
0	3/21	Initial release	—
1	7/22	Updated part number in header and added comment in BOM section	All Pages

Arduino® is a trademark of Arduino SA

Arm and Mbed are registered trademarks or trademarks of Arm Limited (or its subsidiaries) in the US and/or elsewhere.



Looking for pricing, stock, or lifecycle information?

Click below to explore more details on WIN SOURCE:

- ⊖ [View MAX33046ESHLD# on WIN SOURCE](#)
- ⊖ [Maxim Integrated Information](#)

Optimize Your Supply Chain with WIN SOURCE Solutions

- ✓ Global Sourcing Solution
- ✓ Obsolete Management
- ✓ Cost Control Management
- ✓ Shortage Management
- ✓ Alternative Solution
- ✓ Excess Inventory Management