



**THE DATASHEET OF
EVAL-ADM3252EEBZ**



Evaluating the **ADM3252E** Isolated, Dual Channel, RS-232 Line Driver/Receiver

FEATURES

- 2.5 kV fully isolated (power and data) RS-232 transceiver**
- Convenient connections for power and signal via screw terminal blocks**
- 3.3 V or 5 V operation**
- Test points for measuring all signals**
- All external components required included for correct operation**

EVALUATION KIT CONTENTS

ADM3252E evaluation board

GENERAL DESCRIPTION

The **EVAL-ADM3252EEBZ** evaluation board can be used for easy evaluation of the **ADM3252E** isolated RS-232 transceiver. Screw terminal blocks provide convenient connections for the power and signal connections. Test points are included on the power and signal lines on both sides of the isolation barrier. All required external components are included on the evaluation board.

RADIATED EMISSIONS

The **EVAL-ADM3252EEBZ** shown in Figure 1 uses some of the techniques described in the **AN-0971 Application Note, Recommendations for Control of Radiated Emissions with isoPower Devices**, to reduce radiated emissions. These emissions are generated by the high frequency switching elements used by the **isoPower**® technology to transfer power through its transformer. The evaluation board is designed to meet the EN55022 Class B emission standard. See the Radiated Emissions Results section for more details.

EVAL-ADM3252EEBZ EVALUATION BOARD

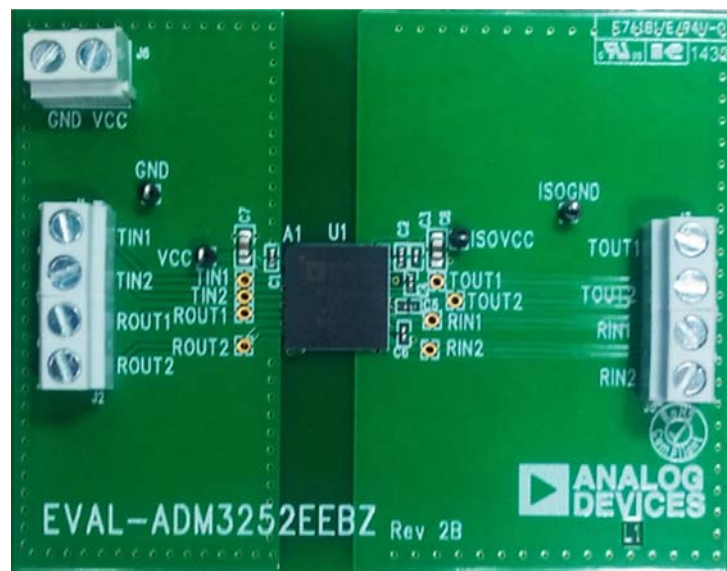

Figure 1.

TABLE OF CONTENTS

Features	1	Connector and Test Point Functions	3
Evaluation Kit Contents.....	1	Evaluation Board Schematics and Artwork.....	4
General Description	1	Radiated Emissions Results.....	8
Radiated Emissions	1	Ordering Information.....	9
EVAL-ADM3252EEBZ Evaluation Board.....	1	Bill of Materials.....	9
Revision History	2		
Evaluation Board Hardware.....	3		

REVISION HISTORY

11/15—Rev. 0 to Rev. A

Changes to Figure 1 and Radiated Emissions Section.....	1
Deleted Figure 4; Renumbered Sequentially.....	5
Changes to Figure 3 and Figure 4.....	5
Changes to Figure 5 and Figure 6.....	6
Changes to Figure 7.....	7
Added Radiated Emissions Results Section, Table 3, Figure 8, and Figure 9; Renumbered Sequentially.....	8
Added Table 4.....	9

7/12—Revision 0: Initial Version

EVALUATION BOARD HARDWARE

CONNECTOR AND TEST POINT FUNCTIONS

Table 1. Connector Functions

Connector	Name	Function
J6	Power connector	J6-1 (VCC) connects positive supply of bench supply to the V _{CC} plane J6-2 (GND) connects ground terminal of bench supply to the GND plane
J1	Signal connector	J1-1 (TIN1) connects to T _{IN1} pin of ADM3252E J1-2 (TIN2) connects to T _{IN2} pin of ADM3252E
J2	Signal connector	J2-1 (ROUT1) connects to R _{OUT1} pin of ADM3252E J2-2 (ROUT2) connects to R _{OUT2} pin of ADM3252E
J3	Signal connector	J3-1 (TOUT1) connects to T _{OUT1} pin of ADM3252E J3-2 (TOUT2) connects to T _{OUT2} pin of ADM3252E
J5	Signal connector	J5-1 (RIN1) connects to R _{IN1} pin of ADM3252E J5-2 (RIN2) connects to R _{IN2} pin of ADM3252E

Table 2. Test Point Functions

Test Point	Function
GND	Connects to GND plane at logic side
VCC	Connects to V _{CC} plane at logic side
TIN1	Connects to T _{IN1} pin of ADM3252E
TIN2	Connects to T _{IN2} pin of ADM3252E
ROUT1	Connects to R _{OUT1} pin of ADM3252E
ROUT2	Connects to R _{OUT2} pin of ADM3252E
ISOVCC	Connects to V _{ISO} plane at RS-232 side
ISOGND	Connects to GND plane at RS-232 side
TOUT1	Connects to T _{OUT1} pin of ADM3252E
TOUT2	Connects to T _{OUT2} pin of ADM3252E
RIN1	Connects to R _{IN1} pin of ADM3252E
RIN2	Connects to R _{IN2} pin of ADM3252E

EVALUATION BOARD SCHEMATICS AND ARTWORK

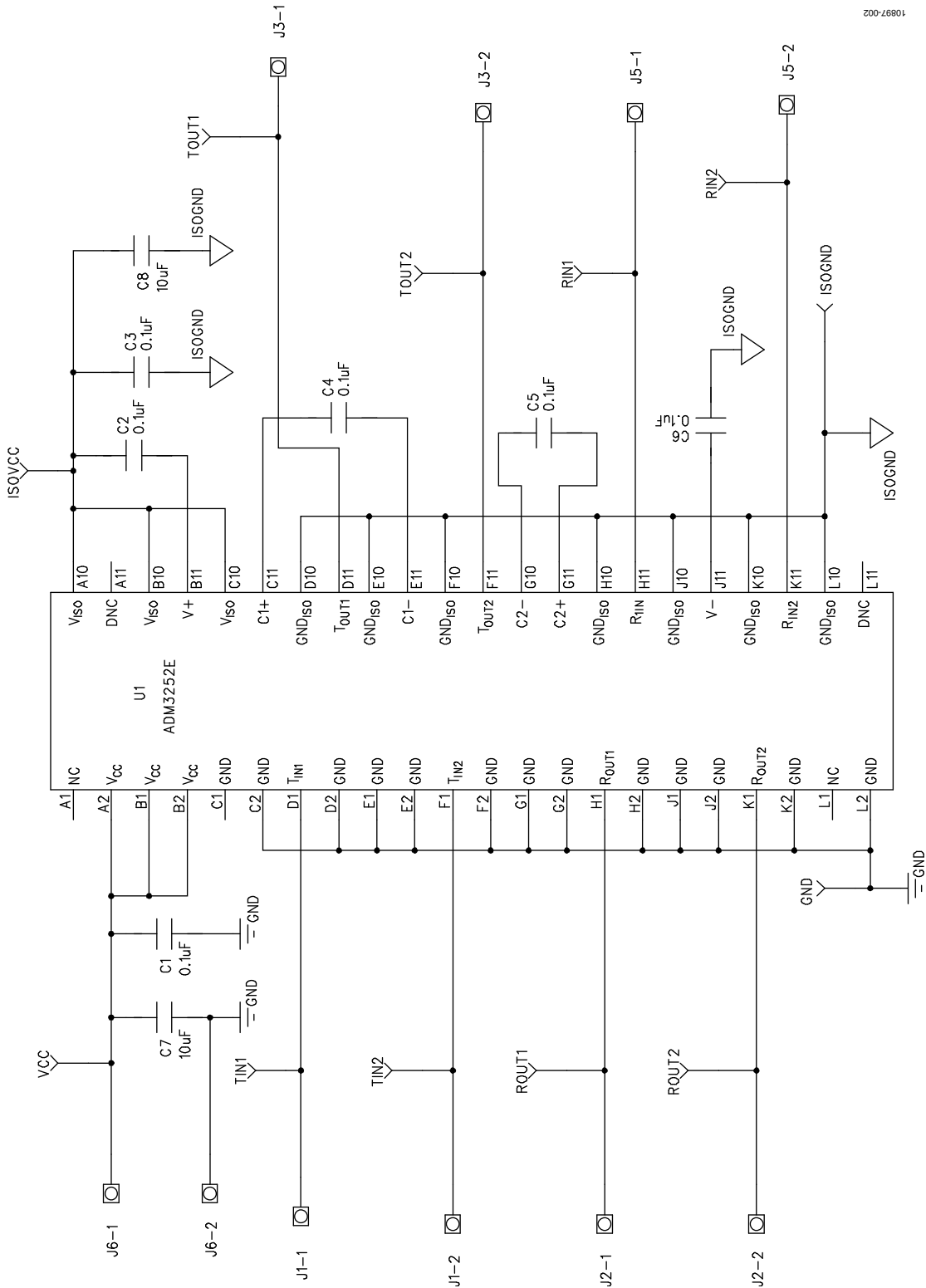

10987-002

Figure 2. ADM3252E Evaluation Board Schematic

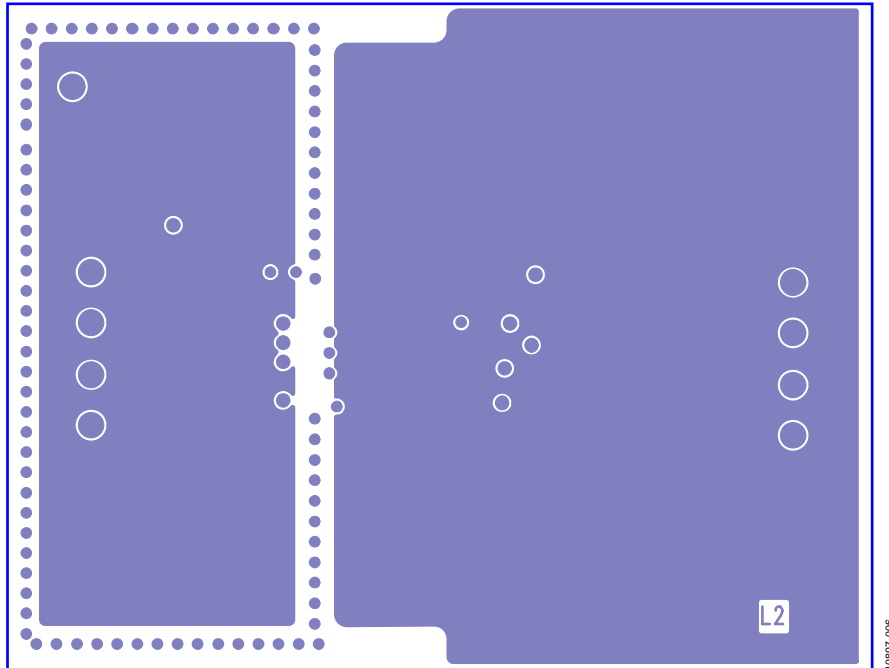

10887-006

Figure 5. EVAL-ADM3252EEBZ Internal Layer 2

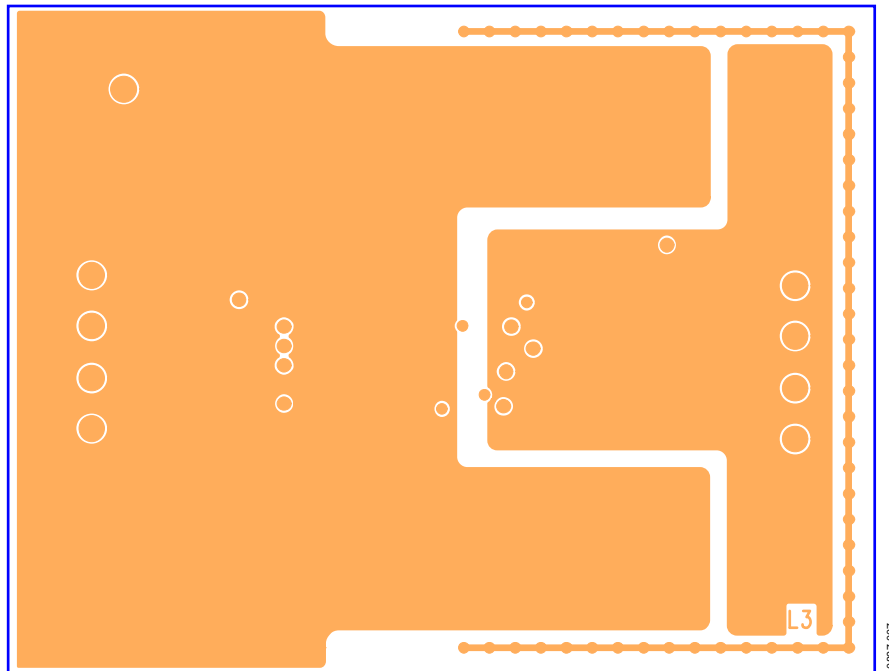

10887-007

Figure 6. EVAL-ADM3252EEBZ Internal Layer 3

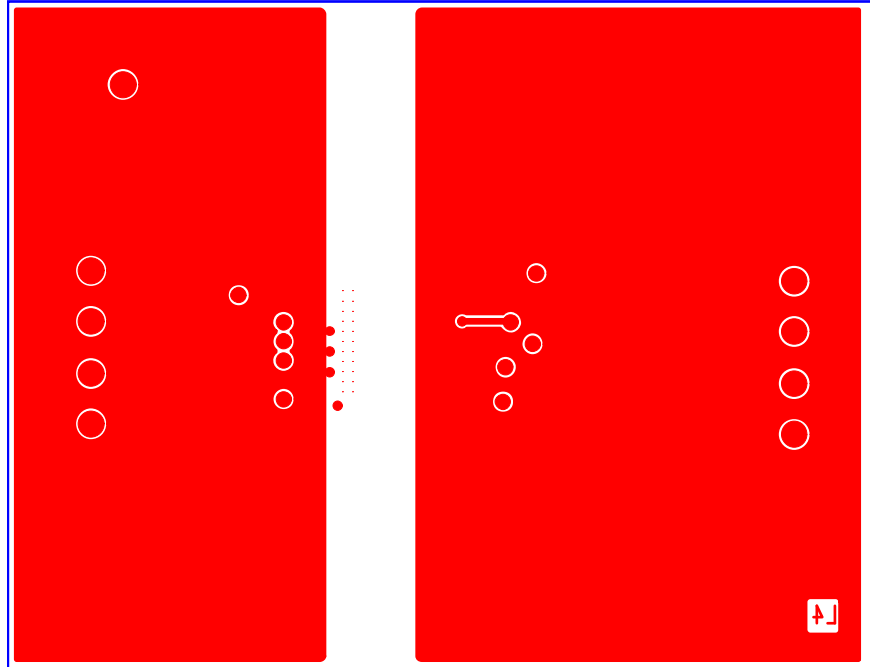

Figure 7. EVAL-ADM3252EEBZ Bottom Layer

10837-008

RADIATED EMISSIONS RESULTS

The EVAL-ADM3252EEBZ evaluation board was tested to EN55022: 2010 (radiated emissions standard). The device was configured and tested with a 3 V, 3.3 V, and 5.5 V dc supply at a data rate of 460 kbps. Each T_{OUTx} pin was loaded with 500 nF of load capacitance and 5 kΩ of load resistance.

Measurements were carried out in an anechoic chamber at 10 m from 30 MHz to 2 GHz. Table 3 shows the list of test equipment used. Figure 8 and Figure 9 show the results of the horizontal and vertical scans. Table 4 shows the tabulated results. There were no emissions detected above 1 GHz.

Table 3. Radiated Emissions Test Equipment

Instrument	Manufacturer	Model
Measuring Receiver	Rohde & Schwarz	ESVS30
Bilog Antenna	Chase	Not applicable
Spectrum Analyzer	Agilent	E4408B
Horn Antenna	EMCO	EMCO 3115

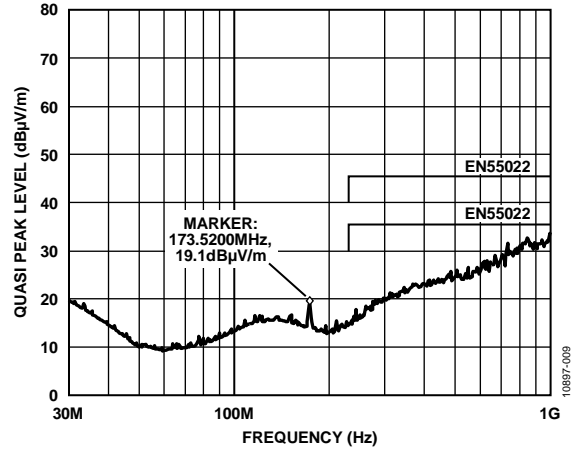

Figure 8. Horizontal Scan from 30 MHz to 1000 MHz

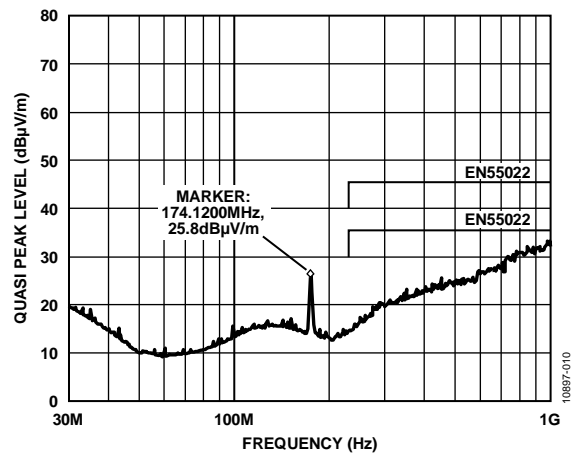

Figure 9. Vertical Scan from 30 MHz to 1000 MHz

Table 4. Radiated Emissions, Class B Limits—Anechoic Chamber at 10 m

V _{CC} (V)	Frequency (MHz)	Quasi Peak Level (µV/m)	EN55022 Class B (µV/m)	Antenna Polarity	Antenna Height (m)	Pass/Fail
3.3	173.672	16.6	30	Vertical	3.3	Pass
3.3	173.500	23.3	30	Horizontal	4.0	Pass
3.0	172.588	15.5	30	Vertical	2.7	Pass
3.0	172.848	28.1	30	Horizontal	4.0	Pass
5.5	174.656	10.6	30	Vertical	1.0	Pass
5.5	190.476	10.6	30	Vertical	1.0	Pass
5.5	190.476	18.1	30	Horizontal	4.0	Pass

ORDERING INFORMATION
BILL OF MATERIALS

Table 5.

Reference Designator	Description	Supplier Part Number
C1, C2, C3, C4, C5, C6	Capacitor, 0.1 μF, 16 V, 0402	Farnell 1288252
C7, C8	Capacitor, 10 μF, 35 V, 0805	Farnell 146-3361
GND, ISOGND, ISOVCC	Test point, black	Farnell 240-333
J1, J2, J3, J5, J6	2-pin terminal block (5 mm pitch)	Farnell 151789
U1	ADM3252E , 44-ball CSP_BGA	Analog Devices, Inc., ADM3252E



ESD Caution

ESD (electrostatic discharge) sensitive device. Charged devices and circuit boards can discharge without detection. Although this product features patented or proprietary protection circuitry, damage may occur on devices subjected to high energy ESD. Therefore, proper ESD precautions should be taken to avoid performance degradation or loss of functionality.

Legal Terms and Conditions

By using the evaluation board discussed herein (together with any tools, components documentation or support materials, the "Evaluation Board"), you are agreeing to be bound by the terms and conditions set forth below ("Agreement") unless you have purchased the Evaluation Board, in which case the Analog Devices Standard Terms and Conditions of Sale shall govern. Do not use the Evaluation Board until you have read and agreed to the Agreement. Your use of the Evaluation Board shall signify your acceptance of the Agreement. This Agreement is made by and between you ("Customer") and Analog Devices, Inc. ("ADI"), with its principal place of business at One Technology Way, Norwood, MA 02062, USA. Subject to the terms and conditions of the Agreement, ADI hereby grants to Customer a free, limited, personal, temporary, non-exclusive, non-sublicensable, non-transferable license to use the Evaluation Board FOR EVALUATION PURPOSES ONLY. Customer understands and agrees that the Evaluation Board is provided for the sole and exclusive purpose referenced above, and agrees not to use the Evaluation Board for any other purpose. Furthermore, the license granted is expressly made subject to the following additional limitations: Customer shall not (i) rent, lease, display, sell, transfer, assign, sublicense, or distribute the Evaluation Board; and (ii) permit any Third Party to access the Evaluation Board. As used herein, the term "Third Party" includes any entity other than ADI, Customer, their employees, affiliates and in-house consultants. The Evaluation Board is NOT sold to Customer; all rights not expressly granted herein, including ownership of the Evaluation Board, are reserved by ADI. CONFIDENTIALITY. This Agreement and the Evaluation Board shall all be considered the confidential and proprietary information of ADI. Customer may not disclose or transfer any portion of the Evaluation Board to any other party for any reason. Upon discontinuation of use of the Evaluation Board or termination of this Agreement, Customer agrees to promptly return the Evaluation Board to ADI. ADDITIONAL RESTRICTIONS. Customer may not disassemble, decompile or reverse engineer chips on the Evaluation Board. Customer shall inform ADI of any occurred damages or any modifications or alterations it makes to the Evaluation Board, including but not limited to soldering or any other activity that affects the material content of the Evaluation Board. Modifications to the Evaluation Board must comply with applicable law, including but not limited to the RoHS Directive. TERMINATION. ADI may terminate this Agreement at any time upon giving written notice to Customer. Customer agrees to return to ADI the Evaluation Board at that time. LIMITATION OF LIABILITY. THE EVALUATION BOARD PROVIDED HEREUNDER IS PROVIDED "AS IS" AND ADI MAKES NO WARRANTIES OR REPRESENTATIONS OF ANY KIND WITH RESPECT TO IT. ADI SPECIFICALLY DISCLAIMS ANY REPRESENTATIONS, ENDORSEMENTS, GUARANTEES, OR WARRANTIES, EXPRESS OR IMPLIED, RELATED TO THE EVALUATION BOARD INCLUDING, BUT NOT LIMITED TO, THE IMPLIED WARRANTY OF MERCHANTABILITY, TITLE, FITNESS FOR A PARTICULAR PURPOSE OR NON-INFRINGEMENT OF INTELLECTUAL PROPERTY RIGHTS. IN NO EVENT WILL ADI AND ITS LICENSORS BE LIABLE FOR ANY INCIDENTAL, SPECIAL, INDIRECT, OR CONSEQUENTIAL DAMAGES RESULTING FROM CUSTOMER'S POSSESSION OR USE OF THE EVALUATION BOARD, INCLUDING BUT NOT LIMITED TO LOST PROFITS, DELAY COSTS, LABOR COSTS OR LOSS OF GOODWILL. ADI'S TOTAL LIABILITY FROM ANY AND ALL CAUSES SHALL BE LIMITED TO THE AMOUNT OF ONE HUNDRED US DOLLARS (\$100.00). EXPORT. Customer agrees that it will not directly or indirectly export the Evaluation Board to another country, and that it will comply with all applicable United States federal laws and regulations relating to exports. GOVERNING LAW. This Agreement shall be governed by and construed in accordance with the substantive laws of the Commonwealth of Massachusetts (excluding conflict of law rules). Any legal action regarding this Agreement will be heard in the state or federal courts having jurisdiction in Suffolk County, Massachusetts, and Customer hereby submits to the personal jurisdiction and venue of such courts. The United Nations Convention on Contracts for the International Sale of Goods shall not apply to this Agreement and is expressly disclaimed.

©2012–2015 Analog Devices, Inc. All rights reserved. Trademarks and registered trademarks are the property of their respective owners.
UG10897-0-11/15(A)



www.analog.com

Looking for pricing, stock, or lifecycle information?

Click below to explore more details on WIN SOURCE:

- ⊖ [View EVAL-ADM3252EEBZ on WIN SOURCE](#)
- ⊖ [Analog Devices Inc. Information](#)

Optimize Your Supply Chain with WIN SOURCE Solutions

- ✓ Global Sourcing Solution
- ✓ Obsolete Management
- ✓ Cost Control Management
- ✓ Shortage Management
- ✓ Alternative Solution
- ✓ Excess Inventory Management