

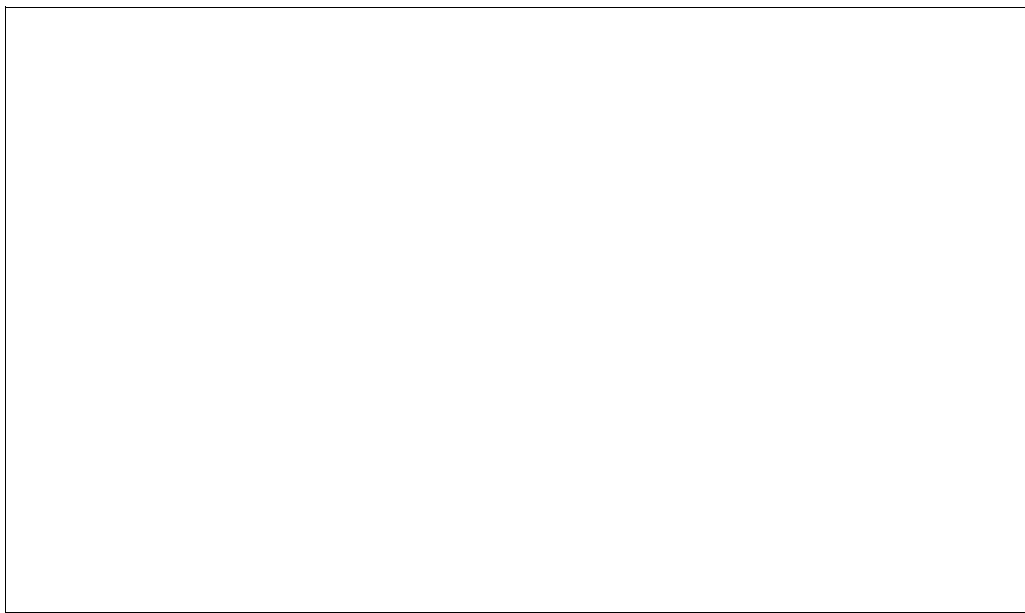

**THE DATASHEET OF  
PMB2201R-V12TR**



# SIEMENS



## ICs for Communications

Mixer DC - 2.5GHz and Vector Modulator 0.8 - 1.5GHz

PMB 2201 Version 1.2

Preliminary Data Sheet 08.97

#### **Edition 08.97**

**Published by Siemens AG,  
Bereich Halbleiter, Marketing-  
Kommunikation, Balanstraße 73,  
81541 München**

© Siemens AG 1995.  
All Rights Reserved.

#### **Attention please!**

As far as patents or other rights of third parties are concerned, liability is only assumed for components, not for applications, processes and circuits implemented within components or assemblies.

The information describes the type of component and shall not be considered as assured characteristics.

Terms of delivery and rights to change design reserved.

For questions on technology, delivery and prices please contact the Semiconductor Group Offices in Germany or the Siemens Companies and Representatives worldwide (see address list).

Due to technical requirements components may contain dangerous substances. For information on the types in question please contact your nearest Siemens Office, Semiconductor Group.

Siemens AG is an approved CECC manufacturer.

#### **Packing**

Please use the recycling operators known to you. We can also help you – get in touch with your nearest sales office. By agreement we will take packing material back, if it is sorted. You must bear the costs of transport.

For packing material that is returned to us unsorted or which we are not obliged to accept, we shall have to invoice you for any costs incurred.

#### **Components used in life-support devices or systems must be expressly authorized for such purpose!**

Critical components<sup>1</sup> of the Semiconductor Group of Siemens AG, may only be used in life-support devices or systems<sup>2</sup> with the express written approval of the Semiconductor Group of Siemens AG.

- 1 A critical component is a component used in a life-support device or system whose failure can reasonably be expected to cause the failure of that life-support device or system, or to affect its safety or effectiveness of that device or system.
- 2 Life support devices or systems are intended (a) to be implanted in the human body, or (b) to support and/or maintain and sustain human life. If they fail, it is reasonable to assume that the health of the user may be endangered.

#### **Ausgabe 08.97**

**Herausgegeben von Siemens AG,  
Bereich Halbleiter, Marketing-  
Kommunikation, Balanstraße 73,  
81541 München**

© Siemens AG 1995.  
Alle Rechte vorbehalten.

#### **Wichtige Hinweise!**

Gewähr für die Freiheit von Rechten Dritter leisten wir nur für Bauelemente selbst, nicht für Anwendungen, Verfahren und für die in Bauelementen oder Baugruppen realisierten Schaltungen.

Mit den Angaben werden die Bauelemente spezifiziert, nicht Eigenschaften zugesichert.

Liefermöglichkeiten und technische Änderungen vorbehalten.

Fragen über Technik, Preise und Liefermöglichkeiten richten Sie bitte an den Ihnen nächstgelegenen Vertrieb Halbleiter in Deutschland oder an unsere Landesgesellschaften im Ausland.

Bauelemente können aufgrund technischer Erfordernisse Gefahrstoffe enthalten. Auskünfte darüber bitten wir unter Angabe des betreffenden Typs ebenfalls über den Vertrieb Halbleiter einzuholen.

Die Siemens AG ist ein Hersteller von CECC-qualifizierten Produkten.

#### **Verpackung**

Bitte benutzen Sie die Ihnen bekannten Verwerter. Wir helfen Ihnen auch weiter – wenden Sie sich an Ihren für Sie zuständigen Vertrieb Halbleiter. Nach Rücksprache nehmen wir Verpackungsmaterial sortiert zurück. Die Transportkosten müssen Sie tragen.

Für Verpackungsmaterial, das unsortiert an uns zurückgeliefert wird oder für das wir keine Rücknahmepflicht haben, müssen wir Ihnen die anfallenden Kosten in Rechnung stellen.

#### **Bausteine in lebenserhaltenden Geräten oder Systemen müssen ausdrücklich dafür zugelassen sein!**

Kritische Bauelemente<sup>1</sup> des Bereichs Halbleiter der Siemens AG dürfen nur mit ausdrücklicher schriftlicher Genehmigung des Bereichs Halbleiter der Siemens AG in lebenserhaltenden Geräten oder Systemen<sup>2</sup> eingesetzt werden.

- 1 Ein kritisches Bauelement ist ein in einem lebenserhaltenden Gerät oder System eingesetztes Bauelement, bei dessen Ausfall berechtigter Grund zur Annahme besteht, daß das lebenserhaltende Gerät oder System ausfällt bzw. dessen Sicherheit oder Wirksamkeit beeinträchtigt wird.
- 2 Lebenserhaltende Geräte und Systeme sind (a) zur chirurgischen Einpflanzung in den menschlichen Körper gedacht, oder (b) unterstützen bzw. erhalten das menschliche Leben. Sollten sie ausfallen, besteht berechtigter Grund zur Annahme, daß die Gesundheit des Anwenders gefährdet werden kann.

## Revision History

#	Subject	Preliminary Data Sheet 5.95		Preliminary Data Sheet 8.97		Change
		Page	Item	Page	Item	
1	Thermal resistance	13	8	13	8	Revised
2	ESD integrity			13	9	Added
3	Supply current	15	1	15	1	Revised
4	External DC voltage at IF/IFX	15	4	15	4	Revised
5	Application Circuit	29		29		Revised

<b>Table of Contents</b>		<b>Page</b>
<b>1</b>	<b>Overview</b> .....	5
1.1	Features .....	5
1.2	Applications: .....	5
1.3	Functional Description .....	6
1.4	Pin Configuration .....	7
1.5	Pin Definitions and Functions .....	8
1.6	Functional Block Diagram .....	9
1.7	Circuit Description .....	10
1.8	Blocks with separate supply, ground and power down pins .....	11
1.9	Internal Input/Output Circuits .....	12
<b>2</b>	<b>Electrical Characteristics</b> .....	13
2.1	Absolute Maximum Ratings .....	13
2.2	Operational Range .....	14
2.3	AC/DC Characteristics .....	15
2.4	S-Parameters and Input/Output Impedances .....	19
2.4.1	Mixer Input RF/RFX .....	20
2.4.2	Mixer Input IF/IFX .....	21
2.4.3	Mixer Output MO/MOX .....	23
2.4.4	Modulator Input LO/LOX .....	24
2.4.5	Modulator Output E/EX .....	26
2.5	Circuits .....	28
2.5.1	Test Circuit .....	28
2.5.2	Application Circuit .....	29
<b>3</b>	<b>Package Outlines</b> .....	31

# SIEMENS

Mixer DC - 2.5GHz and Vector Modulator 0.8 - 1.5GHz

PMB 2201

Version 1.2

Bipolar IC

## 1 Overview

### 1.1 Features

- Direct quadrature modulator with separate additional double balanced active mixer
- Direct quadrature modulation
- LO frequency range from 800 MHz to 1.5 GHz
- Generation of orthogonal carriers without external elements and without trimming
- typ. 40 dB carrier rejection, typ. 44 dB SSB rejection
- typ. 43 dB rejection of third order products at 1 Vpp A/B drive level at  $f_{LO} = 1.5$  GHz
- 3 dBm output power with appropriate output power matching network and at 1Vpp A/B baseband drive level
- Double balanced Gilbert cell mixer
- RF and IF frequency range from DC to 2.5 GHz
- typ. 39 dB carrier rejection
- low noise
- Supply voltage range from 2.7 V to 4.5 V
- Power down mode
- P-TSSOP-24 package
- Temperature range  $-30^{\circ}$  to  $85^{\circ}$ C

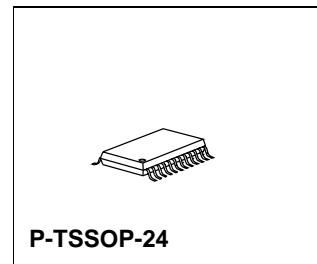

### 1.2 Applications:

- Vector modulated digital mobile cellular systems as GSM, PDC-800, PDC-1.5, DAMPS etc.
- Various modulation schemes, such as PM, PSK, FSK, QAM, QPSK, GMSK etc.
- Analog systems with FM and AM modulation
- Space and power saving optimizations of existing discrete transmitter circuits

Type	Ordering Code	Package
PMB 2201	Q67006-A6137 (T+R)	P-TSSOP-24

**1.3 Functional Description**

The PMB2201 is a modulator and mixer circuit with high integration level. It includes a direct quadrature modulator and a double balanced Gilbert cell mixer with according bias circuitry.

The up/down conversion mixer combines two external signals at the RF and IF inputs. The IF input is suited for the lower frequency signal because of its linear transfer function to the mixer output. The higher frequency signal is fed to the RF input to switch the Gilbert cell mixer. In a typical application the wanted mixer output product is bandpass filtered and then fed to the modulator LO input. The mixer may also be used to convert the modulator output signal from E/EX via the IF/IFX input by mixing with a local oscillator signal RF/RFX to higher frequencies up to 2.5 GHz.

The modulator generates two orthogonal carriers which are mixed with the baseband modulation signals A and B in Gilbert multipliers. The outputs of the Gilbert cells are added and amplified by a linear output stage. The modulated signal is available at the open collector output E,EX. The voltage TREF can be used for DC biasing of the modulation inputs A, AX, B, BX externally.

The modulator and the mixer have separate power supplies and grounds. They can be powered down independently. Due to the power down concept the modulator can be used without or in conjunction with the up/down conversion mixer part.

For applications in the frequency range from 1.4GHz to 2.5GHz the derivative PMB2202 is offered.

1.4 Pin Configuration  
(top view)

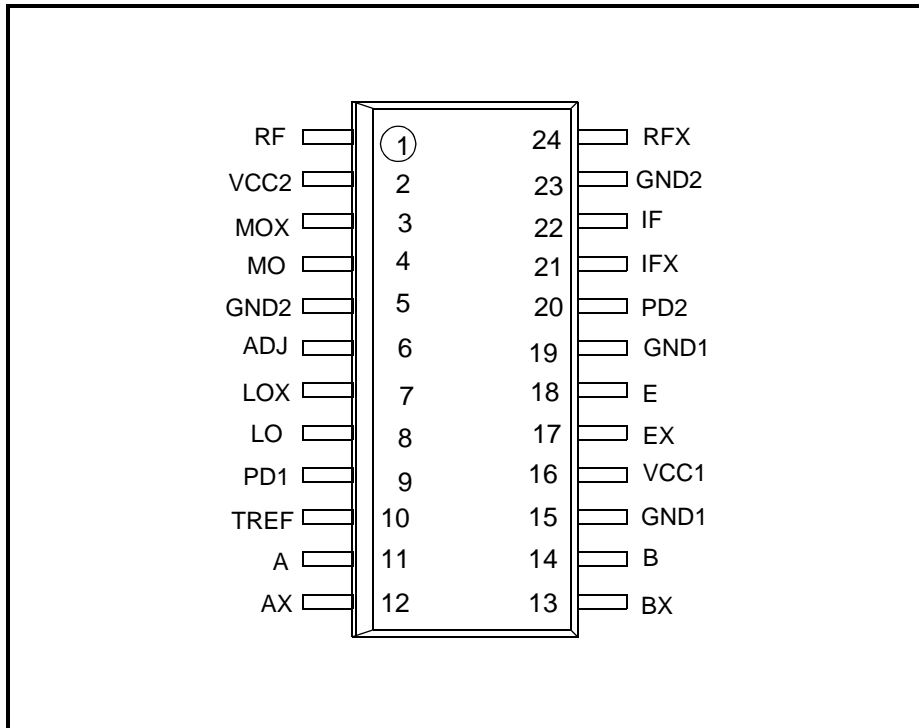

P-TSSOP-24

**1.5 Pin Definitions and Functions**

<b>Pin No.</b>	<b>Symbol</b>	<b>Function</b>
1	RF	RF input, base input
2	VCC2	Supply voltage for mixer
3	MOX	Mixer output inverted, open collector
4	MO	Mixer output, open collector
5,23	GND2	Ground for mixer
6	ADJ	Phase adjust input
7	LOX	Modulator LO input inverted
8	LO	Modulator LO input
9	PD1	Power down for modulator
10	TREF	DC bias voltage for modulation inputs A, AX, B, BX
11	A	Modulation input A
12	AX	Modulation input A inverted
13	BX	Modulation input B inverted
14	B	Modulation input B
15, 19	GND1	Ground for modulator
16	VCC1	Supply voltage for modulator
17	EX	Modulator output inverted, open collector
18	E	Modulator output, open collector
20	PD2	Power down for mixer
21	IFX	IF input inverted, emitter input
22	IF	IF input, emitter input
24	RFX	RF input inverted, base input

1.6 Functional Block Diagram

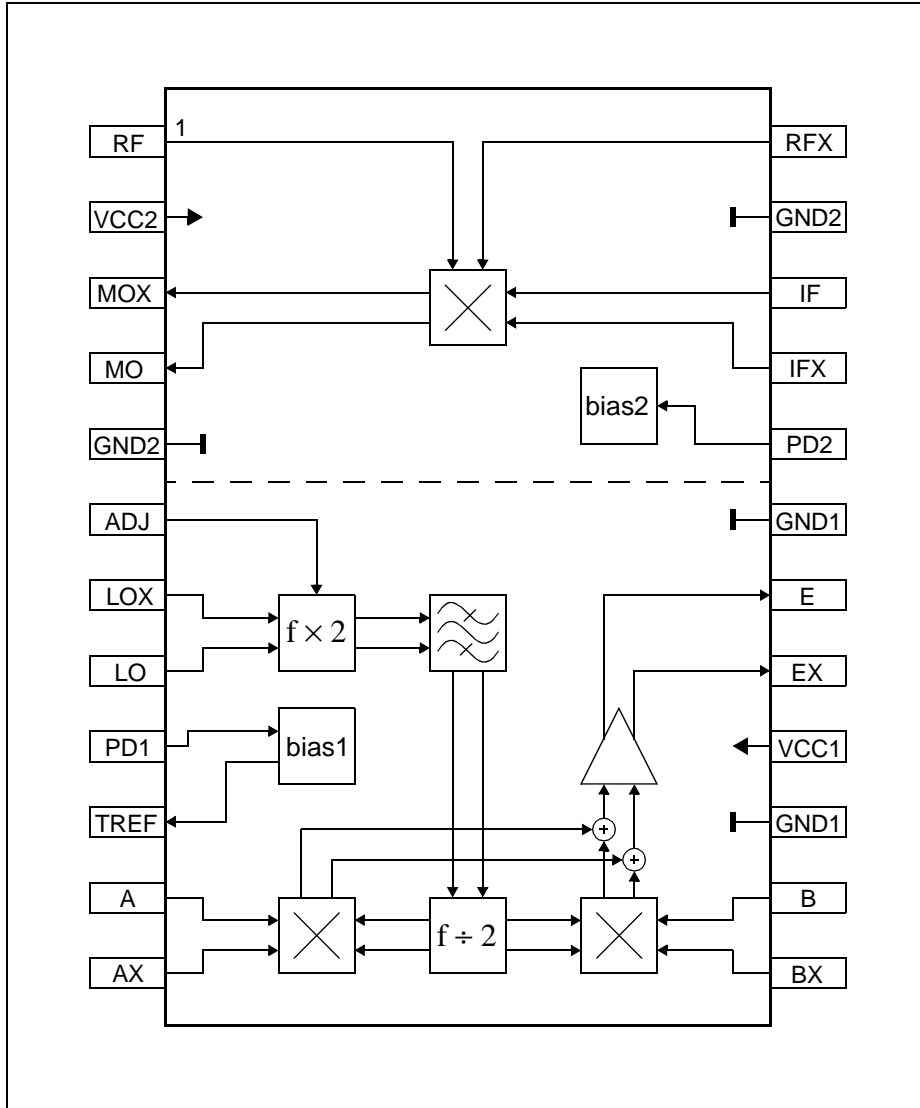

## 1.7 Circuit Description

### Block Level Description

The PMB2201 includes an up/down conversion mixer and a direct quadrature modulator on one chip.

The mixer is a fully balanced Gilbert cell. The IF, IFX pins are low impedance inputs. The transfer function from this input to the mixer output is linear for input levels below the 1dB compression point. For improved intermodulation the mixer current can be increased with external resistors to GND2 at IF, IFX. The RF, RFX pins are high impedance inputs and are DC connected to the bases of the transistors in the Gilbert cell. The input level at RF, RFX should be high enough to ensure proper switching of the differential transistor pairs. The mixer output pins MO, MOX are high impedance open collector outputs. The wanted mixer output product can be band pass filtered and fed to the LO, LOX input of the modulator or to an external load.

The LO, LOX pins are the high impedance inputs of an emitter coupled differential pair. The LO signal is internally divided into two orthogonal carriers at the transmit frequency. The modulator has two Gilbert cell multipliers, in which the modulation signals A(t) and B(t) are mixed with the orthogonal carriers. The outputs of both Gilbert cells are added and amplified by a linear output stage. The modulated transmit signal is available at the high impedance open collector outputs E/EX and can be fed to a power amplifier.

At the output TREF a DC voltage for biasing the modulation inputs A, AX, B, BX is available, which should be capacitively decoupled to ground. The modulation inputs can be connected externally via bias resistors to TREF. Due to the low voltage concept a balanced drive of the differential modulator inputs is recommended to obtain the best second and third order spurious suppression.

The phase adjust input ADJ allows the single sideband suppression of the modulator to be optimized for a particular application. If the specified sideband suppression is sufficient, ADJ should only be capacitively decoupled to ground, in which case the voltage at ADJ is set internally to half the TREF voltage. If a higher suppression is required, the voltage at ADJ can be adjusted to the optimum value by a pull-up resistor to TREF, a pull-down resistor to GND1 or a potentiometer between TREF and GND1.

The modulator and the mixer have separate supply, ground and power down pins: VCC1, GND1, PD1 for the modulator and VCC2, GND2, PD2 for the mixer. Applying a logic LOW to PD1 or PD2 powers down the corresponding part of the chip, including its bias circuitry. Depending on the application the power down pins can be combined or separately fixed to supply rails.

1.8 Blocks with separate supply, ground and power down pins

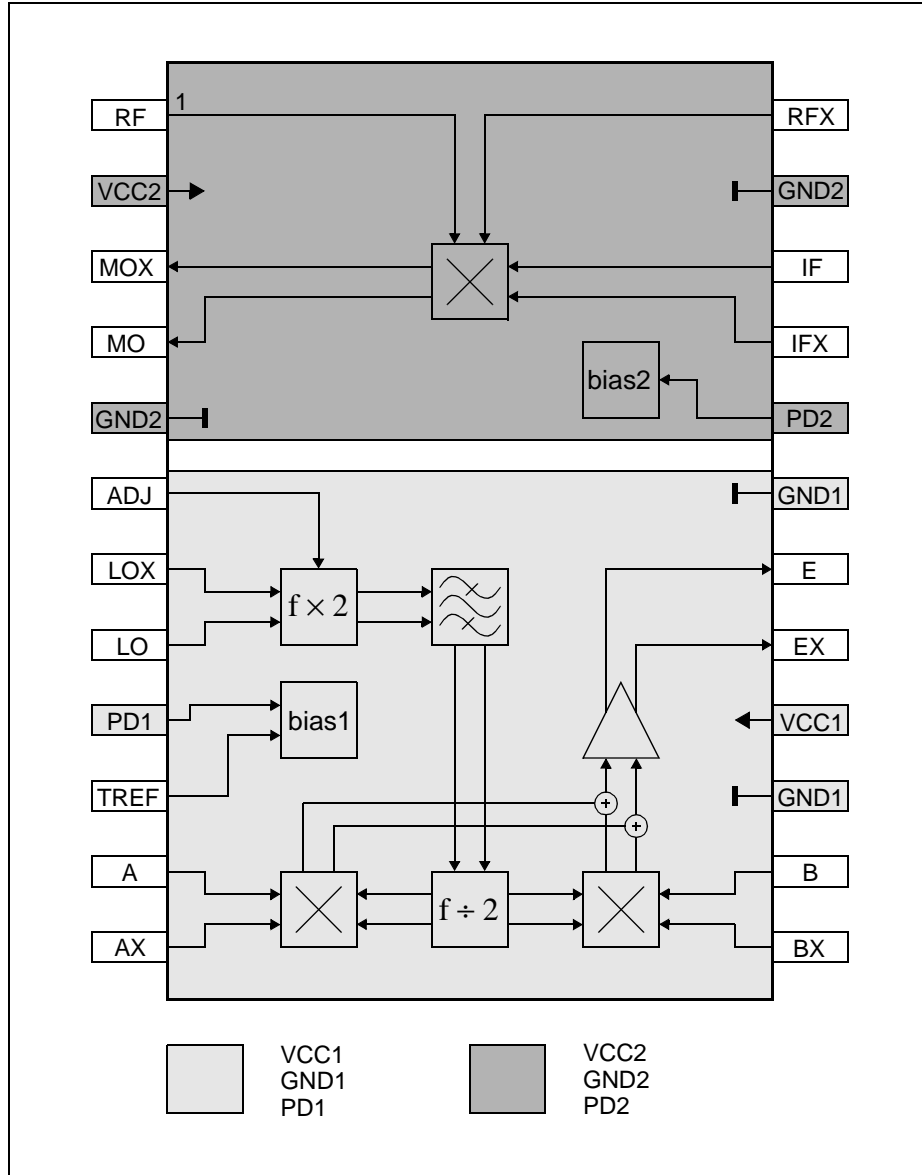

1.9 Internal Input/Output Circuits

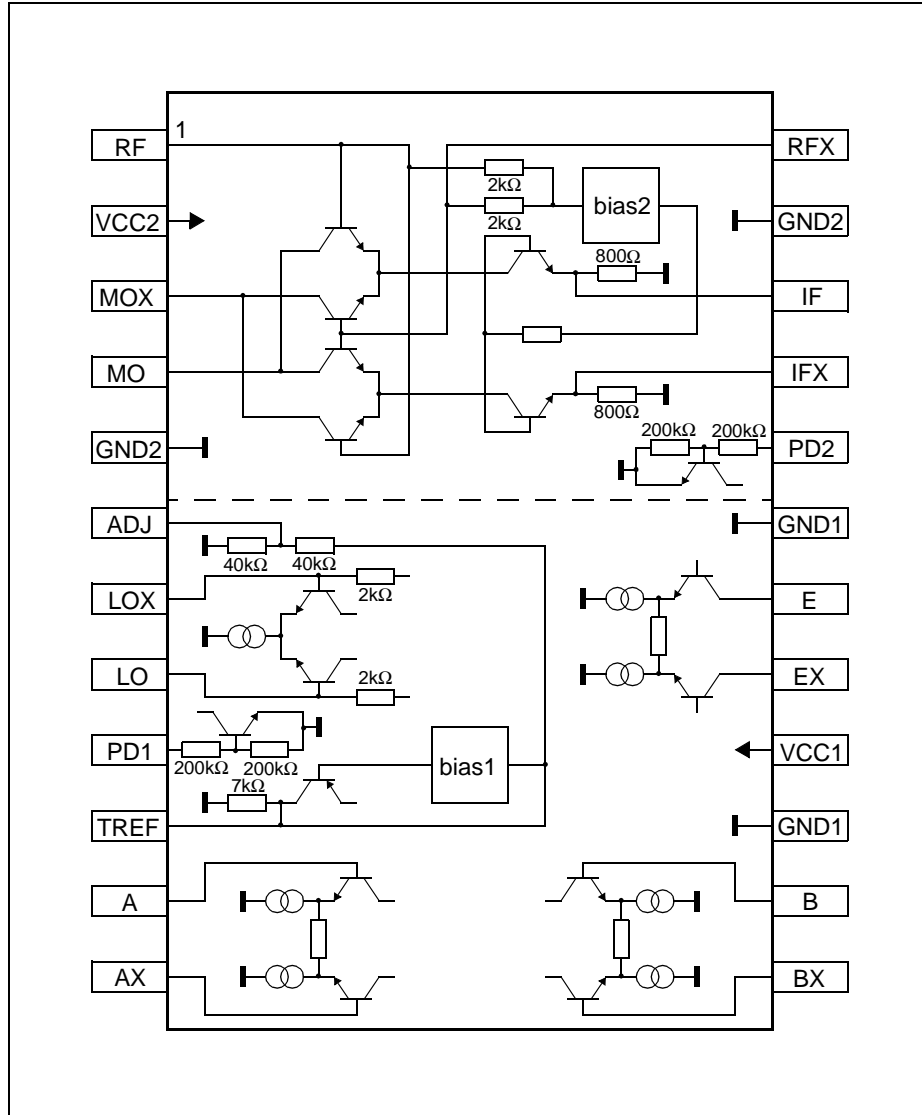

**2 Electrical Characteristics**

**2.1 Absolute Maximum Ratings**

The maximum ratings may not be exceeded under any circumstances, not even momentarily and individually, as permanent damage to the IC will result.

#	Parameter	Symbol	Limit Values		Units	Remarks
			Min	Max		
1	Supply Voltage	$V_{CC}$	-0,5	4.5	V	
2	Input Voltage	$V_{IO}$	-0.5	$V_{CC} + 0.5$	V	of PD1, PD2
3	Open Collector Output Voltage (MO, MOX, E, EX)	$V_{OC}$	-0.5	$V_{CC} + 0.5$	V	
4	Differential Input Voltage (any differential Input)	$V_I$	-2	2	V	
5	Input current (IF, IFX)	$I_{IF}$		10	mA	
6	Junction Temperature	$T_j$		125	°C	
7	Storage Temperature	$T_S$	-55	125	°C	
8	Thermal Resistance (junction to lead)	$R_{thJL}$		140	K/W	
9	ESD Integrity *	$V_{ESD}$	-1000	1000	V	according MIL-STD 883D, method 3015.7 and EOS/ESD assn. standard S5.1 - 1993

\* The RF pins 3,4,17 and 18 are not protected against voltage stress > 300V (versus VS or GND).

The high frequency performance prohibits the use of adequate protective structures.

**2.2 Operational Range**

Within the operational range the IC operates as described in the circuit description. The AC/DC characteristic limits are not guaranteed.

Supply voltage  $V_{VCC} = 2.7V...4.5V$ , Ambient temperature  $T_{amb} = -30^{\circ}C...85^{\circ}C$

#	Parameter	Symbol	Limit Values		Units
			Min	Max	
1	VCC1, VCC2 Supply	$V_{CC1}, V_{CC2}$	2.7	4.5	V
2	PD-Signals Voltage-L	$V_{PDL}$	0	0.8	V
3	PD-Signals Voltage-H	$V_{PDH}$	2.1	$V_{CC}$	V

**Mixer section**

4	RF, RFX input frequency	$f_{RF}$	DC	2.5	GHz
5	RF, RFX input level	$P_{RF}$		0	dBm
6	IF, IFX input frequency	$f_{IF}$	DC	2.5	GHz
7	IF, IFX input level	$P_{IF}$		0	dBm
8	MO, MOX output frequency	$f_{MO}$	DC	2.5	GHz
9	Minimum resistive load R2, R3 at IF, IFX to GND	$R_2, R_3$ in Test Circuit 1	33		$\Omega$

**Modulator section**

10	LO, LOX input frequency	$f_{LO}$	800	1500	MHz
11	LO, LOX input level	$P_{LO}$	-15	0	dBm
12	A, AX, B, BX input frequency	$f_A, f_B$	DC	400	MHz
13	A, AX, B, BX input level	$V_A, V_{AX},$ $V_B, V_{BX}$	1.4	$V_{CC1}-0.6$	V
14	A-AX, B-BX differential input signal level	$V_{A-AX},$ $V_{B-BX}$		1	$V_{pp}$

*Note: Power levels refer to 50 Ohms impedance*

**2.3 AC/DC Characteristics**

AC/DC characteristics involve the spread of values guaranteed within the specified supply voltage and ambient temperature range. Typical characteristics are the median of the production.

Supply voltage  $V_{VCC} = 2.7V \dots 4.5V$ , Ambient temperature  $T_{amb} = +25^{\circ}C$

#	Parameter	Symbol	Limit Values			Unit	Test Conditions	Test-Circuit
			Min	Typ	Max			

**Supply Current**

1	Supply current with all powered up	$I_{VCC1}$	13	17	21	mA	PD1 & PD2 = H	1
		$I_E + I_{EX}$	9	12	15	mA		
		$I_{VCC2}$	0.3	0.6	1.0	mA		
		$I_{MO} + I_{MOX}^*$	5	7	9	mA		
2	Supply current with all powered down	$I_{VCC1}$			2	$\mu A$	PD1 & PD2 = L	1
		$I_E + I_{EX}$			2	$\mu A$		
		$I_{VCC2}$			2	$\mu A$		
		$I_{MO} + I_{MOX}$			2	$\mu A$		
3	Power up settling time **	$t_{PU}$		2		$\mu s$	1nF at TREF 100pF at ADJ Modulator inputs DC coupled	

**Mixer section**

**Mixer Input**

4	Internal DC voltage at IF/IFX ***	$V_{DCIF}$		0.30		V		1
5	Internal DC voltage at RF/RFX	$V_{DCRF}$		2.0		V		1

\* The mixer current decreases when no external resistors to ground are connected at IF and IFX as in the test circuit 1 from the preliminary data sheet 9.95. In this case the typical value of  $I_{MO} + I_{MOX}$  is 1mA.

\*\*  $t_{PU}$  is determined by the time needed to charge the external capacitors.

\*\*\* Note: There are external resistors (82 Ohms) at IF and IFX to ground.

**AC/DC Characteristics**

AC/DC characteristics involve the spread of values guaranteed within the specified supply voltage and ambient temperature range. Typical characteristics are the median of the production.

Supply voltage  $V_{VCC} = 2.7V$  to  $4.5V$ , Ambient temperature  $T_{amb} = +25^{\circ}$

#	Parameter	Symbol	Limit Values			Unit	Test Conditions	Test-Circuit
			Min	Typ	Max			

**Mixer Output MO/MOX:**

6	Power gain*	G		3		dB		Application Circuit
7	Output power**	$P_{MO}$	-12	-9	-6	dBm	$P_{RFIN} = -5dBm$ $f_{RFIN} = 1.4 GHz$ $P_{IFIN} = -5dBm$ $f_{IFIN} = 400 MHz$	1
8	1dB compression point*	$P_{IF1dB}$		-7		dBm	$P_{RFIN} > -4dBm$	Application Circuit
9	Noise figure*	$N_{IF}$		8		dB	DSB Noise, $f=1GHz$	
10	Carrier suppression**	$a_C$	25	39		dB	$P_{RFIN} = -5dBm$ $f_{RFIN} = 1.4 GHz$ $P_{IFIN} = -5dBm$ $f_{IFIN} = 400 MHz$	1

\* Design hint

\*\* These values changed compared to the preliminary data sheet 9.95 due to changes in the test circuit 1. The internal circuit of the mixer is the same.

**AC/DC Characteristics**

AC/DC characteristics involve the spread of values guaranteed within the specified supply voltage and ambient temperature range. Typical characteristics are the median of the production.

Supply voltage  $V_{VCC} = 2.7V \dots 4.5V$ , Ambient temperature  $T_{amb} = +25^{\circ}C$

#	Parameter	Sym- bol	Limit Values			Unit	Test Condition	Test Circuit
			min.	typ.	max.			

**Modulator section**

**Modulator LO Input at LO, LOX**

11	Internal DC voltage at LO, LOX	$V_{DCL0}$		$V_{CC1} - 0.7V$		V		1
----	--------------------------------	------------	--	------------------	--	---	--	---

**Modulator Inputs A/AX and B/BX**

12	Input DC current at A, AX, B, BX	$I_A, I_{AX}, I_B, I_{BX}$		5	10	$\mu A$	Differential input voltage = 0V	1
13	Differential input offset current	$I_{OSA}, I_{OSB}$	-1		1	$\mu A$		1
14	Differential input resistance*	$R_{A/AX}, R_{B/BX}$	125	250		$k\Omega$	$f_{A,B} = 100 \text{ kHz}$	
15	Differential input capacitance*	$C_{A/AX}, C_{B/BX}$		1		pF	$f_{A,B} = 100 \text{ kHz}$	

**DC bias TREF for A/AX and B/BX inputs**

16	Reference voltage for A, B modulating inputs	$V_{TREF}$	1.65	1.75	1.85	V		1
17	Minimum decoupling capacitance at TREF*	$C_{TREF}$	1			nF		
18	Maximum load current at TREF*	$I_{LMAX}$			1.0	mA		

\* Design hint

**AC/DC Characteristics**

AC/DC characteristics involve the spread of values guaranteed within the specified supply voltage and ambient temperature range. Typical characteristics are the median of the production.

Supply voltage  $V_{VCC} = 2.7V \dots 4.5V$ , Ambient temperature  $T_{amb} = +25^\circ C$

#	Parameter	Sym- bol	Limit Values			Unit	Test Condition	Test Circuit
			min.	typ.	max.			

**Phase adjust input ADJ**

19	Open circuit voltage	$V_{ADJ}$		880		mV		1
20	Input impedance	$R_{ADJ}$		20		k $\Omega$		

**Modulator output E/EX:  $f_{A,B}=10MHz$ ;  $V_{A,B}=1V_{pp}$ ;  $90^\circ$  phase shift;  $P_{LO}=-10dBm$**

21	Output power	$P_{E/EX}$	-6	-2	2	dBm		1
22	Output power for power matching *	$P_{E/EX}$		3		dBm	$f_{LO} = 1429MHz$	Appl. circuit
23	Carrier suppression **	$a_C$	32 30	47 40		dB dB	$f_{LO} = 800MHz$ $f_{LO} = 1500MHz$	1
24	Single sideband suppression ***	$a_{ssb}$	35	44		dB		1
25	Suppression of third order distortion products ****	$a_{IM3}$	28 35	32 43		dB dB	$f_{LO} = 800 MHz$ $f_{LO} = 1500 MHz$	1
26	Output noise floor *	$P_N$		-140		dBc /Hz	$f_{LO} = 915MHz-$ $f_{meas} = 935MHz$	

\* Application hint

\*\* The carrier suppression can be optimized for a particular application using offset voltages at the baseband inputs A/AX and B/BX. The optimum values can be found iteratively by adjusting the A/AX and B/BX offsets alternately until the carrier disappears into the noise floor. If the actual offset voltages differ from their optimum values by  $\Delta V_{OSA}$  and  $\Delta V_{OSB}$ , the carrier suppression in dB is given by

$$a_c = 20 \cdot \log_{10} \left[ \frac{V_m}{\sqrt{(\Delta V_{OSA})^2 + (\Delta V_{OSB})^2}} \right]$$

where  $V_m$  is the peak value of the signal voltage at A/AX and B/BX.

\*\*\* Phase adjust pin ADJ not used.

\*\*\*\*  $a_{IM3}$  can be increased by reducing the amplitude of the modulator inputs  $V_{A-AX}$  and  $V_{B-BX}$ .

**2.4 S-Parameters and Input/Output Impedances**

The S-parameters provided in this section are based on measurements at the supply voltage of  $VCC = 3.6V$ . Via the internal bias tees of the NWA the capacitive coupling is done and the open collector pins are connected to VCC.

The S-parameters have to be considered as application hints.

Test	Frequency [MHz]	Port 1	Port 2	Output levels
RF-Input impedance	25 - 2500	RF	RFX	-5 dBm
IF-Input impedance	25 - 2500	IF	IFX	-30 dBm
MO-Output impedance	25 - 2500	MO	MOX	-30 dBm
LO-Input impedance	800 - 1500	LO	LOX	-5 dBm
E-Output impedances	800 - 1500	E	EX	-30 dBm

The input/output impedances are calculated from these parameters. The impedances are given as equivalent circuit with lumped elements for differential and single ended in-/outputs.

As equivalent circuit for these in-/outputs a resistor  $R_p$  parallel to a capacitance  $C_p$  is derived:

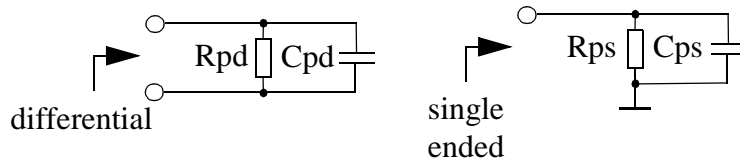

The IF-Input impedance is given as a equivalent circuit of a resistor  $R_s$  serial to a inductivity  $L_s$ .

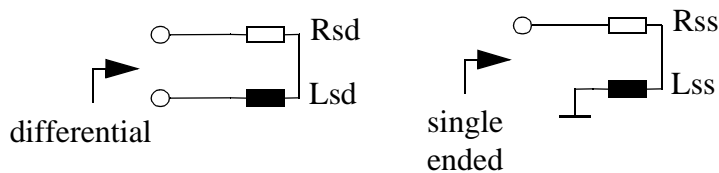

2.4.1 Mixer Input RF/RFX

Circuit for measurement:

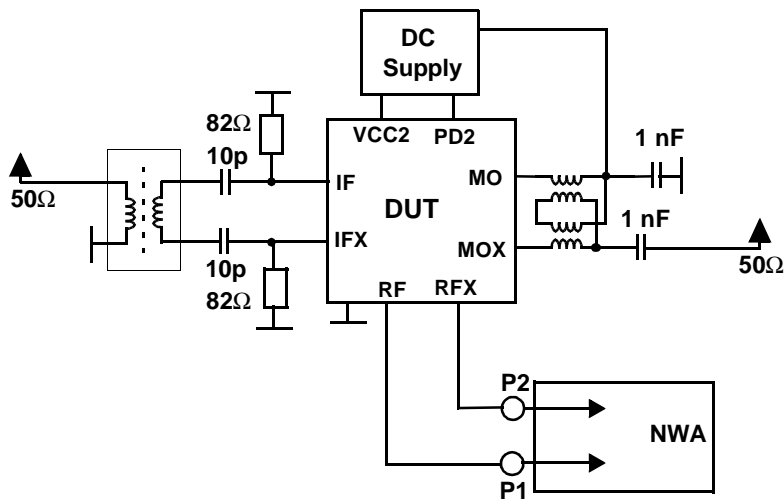

Mixer Input RF/RFX S-Parameters:

f	S11		S21		S12		S22	
MHz	MAG	ANG	MAG	ANG	MAG	ANG	MAG	ANG
25	0.953	-0.7	0.025	8.6	0.025	8.8	0.953	-0.7
250	0.942	-7.5	0.032	47.1	0.029	43.7	0.942	-7.8
500	0.922	-15.2	0.060	62.1	0.055	65.0	0.926	-15.6
750	0.902	-23.3	0.091	59.0	0.085	64.2	0.910	-23.7
1000	0.872	-32.5	0.123	50.7	0.119	57.0	0.887	-32.7
1250	0.836	-41.5	0.145	44.6	0.144	52.4	0.867	-41.4
1500	0.787	-50.1	0.171	37.5	0.177	46.5	0.840	-50.5
1750	0.738	-58.0	0.196	31.1	0.207	40.5	0.808	-59.7
2000	0.688	-66.0	0.233	22.5	0.253	30.9	0.769	-69.6
2250	0.635	-77.1	0.261	12.1	0.290	20.4	0.715	-82.5
2500	0.567	-92.0	0.276	1.1	0.321	9.7	0.636	-98.7

Mixer Input RF/RFX Impedances:

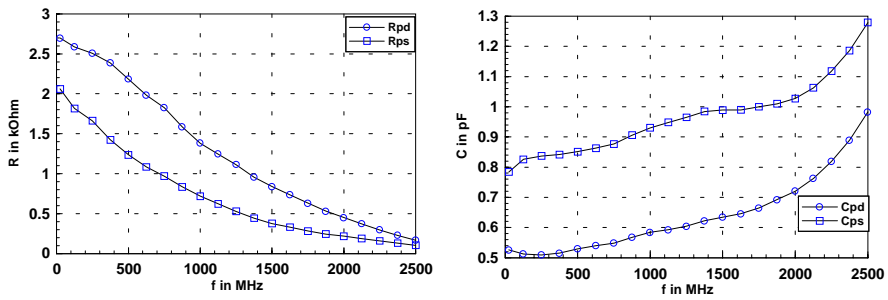

2.4.2 Mixer Input IF/IFX

Circuit for measurement:

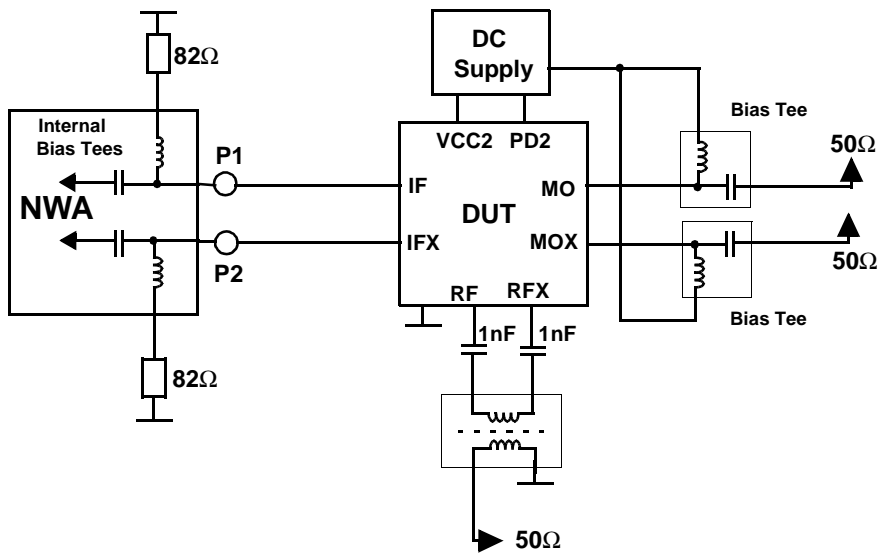

Mixer Input IF/IFX S-Parameters:

f	S11		S21		S12		S22	
MHz	MAG	ANG	MAG	ANG	MAG	ANG	MAG	ANG
25	0.445	174.3	0.248	7.5	0.247	7.9	0.444	174.3
250	0.314	150.0	0.408	8.7	0.410	9.3	0.314	149.9
500	0.280	144.9	0.426	-2.3	0.428	-1.8	0.279	145.3
750	0.285	139.6	0.417	-9.1	0.420	-8.6	0.287	141.1
1000	0.303	134.4	0.397	-14.7	0.402	-13.9	0.308	136.7
1250	0.327	128.8	0.372	-18.7	0.378	-18.4	0.335	131.0
1500	0.361	122.6	0.347	-21.6	0.353	-21.1	0.358	123.9
1750	0.401	115.0	0.322	-23.9	0.329	-23.0	0.383	116.1
2000	0.446	106.6	0.296	-24.8	0.307	-23.8	0.417	107.5
2250	0.501	98.0	0.275	-22.3	0.292	-22.3	0.461	97.4
2500	0.549	88.2	0.287	-19.1	0.305	-21.8	0.501	85.3

Mixer Input IF/IFX Impedances:

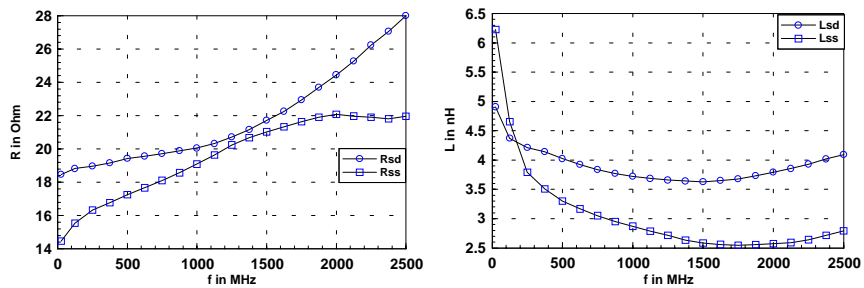

2.4.3 Mixer Output MO/MOX

Circuit for measurement:

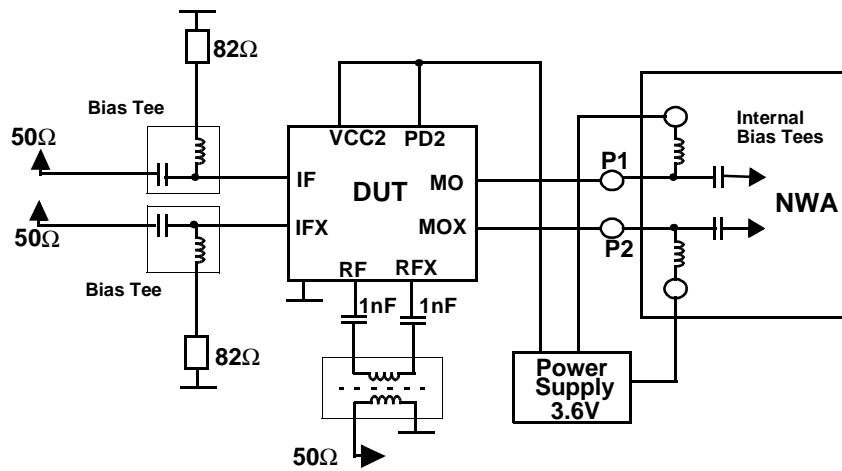

Mixer Output MO/MOX S-Parameters:

f	S11		S21		S12		S22	
MHz	MAG	ANG	MAG	ANG	MAG	ANG	MAG	ANG
25	0.995	-0.7	0.005	2.4	0.005	-2.7	0.997	-0.7
250	0.987	-6.7	0.013	115.8	0.013	119.2	0.984	-7.5
500	0.975	-13.4	0.040	100.7	0.040	103.1	0.970	-14.8
750	0.957	-20.4	0.062	89.2	0.063	91.0	0.952	-23.0
1000	0.935	-27.3	0.080	82.4	0.080	84.4	0.931	-31.8
1250	0.911	-34.2	0.095	78.4	0.096	81.4	0.895	-40.7
1500	0.890	-40.8	0.108	72.5	0.113	75.8	0.870	-48.7
1750	0.871	-47.3	0.106	68.2	0.115	70.2	0.857	-56.6
2000	0.847	-54.1	0.099	73.2	0.108	74.1	0.834	-65.1
2250	0.814	-61.7	0.097	85.2	0.110	82.9	0.797	-73.8
2500	0.775	-71.6	0.115	106.5	0.125	97.0	0.751	-84.2

Mixer Output MO/MOX Impedances:

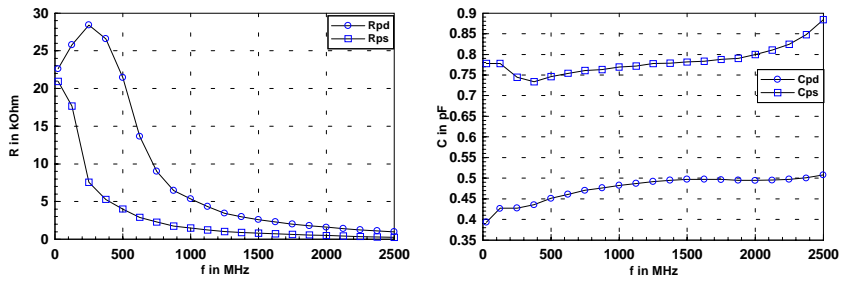

2.4.4 Modulator Input LO/LOX

Circuit for measurement:

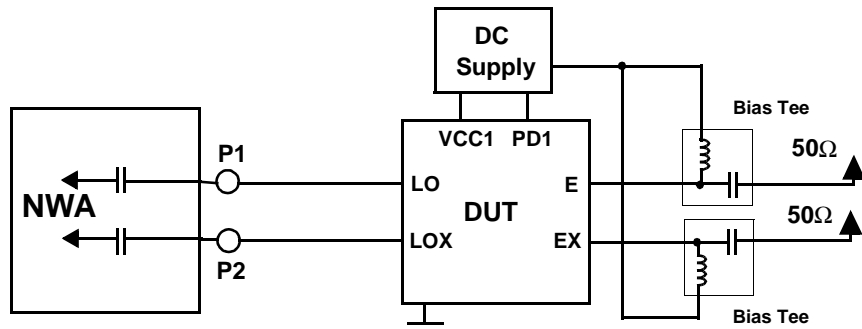

Modulator Input LO/LOX S-Parameters:

f	S11		S21		S12		S22	
	MAG	ANG	MAG	ANG	MAG	ANG	MAG	ANG
800	0.940	-20.1	0.041	63.8	0.041	63.8	0.937	-17.3
850	0.934	-21.4	0.043	67.5	0.043	67.5	0.931	-18.5
900	0.928	-22.7	0.047	70.2	0.047	70.3	0.925	-19.6
950	0.923	-24.0	0.051	71.6	0.051	71.5	0.919	-20.7
1000	0.919	-25.2	0.055	71.9	0.055	71.9	0.914	-21.9
1050	0.914	-26.6	0.058	72.0	0.058	72.0	0.909	-23.1
1100	0.910	-27.9	0.061	72.4	0.061	72.4	0.904	-24.2
1150	0.905	-29.1	0.065	72.6	0.064	72.7	0.898	-25.3
1200	0.900	-30.4	0.069	72.4	0.069	72.4	0.893	-26.4
1250	0.896	-31.5	0.073	71.3	0.073	71.4	0.889	-27.5
1300	0.893	-32.7	0.076	69.4	0.076	69.5	0.887	-28.5
1350	0.891	-33.9	0.078	67.3	0.078	67.4	0.885	-29.6
1400	0.888	-35.1	0.079	65.2	0.079	65.3	0.883	-30.8
1450	0.886	-36.4	0.079	63.6	0.079	63.6	0.881	-32.0
1500	0.884	-37.7	0.078	62.3	0.078	62.3	0.878	-33.3

Modulator Input LO/LOX Impedances:

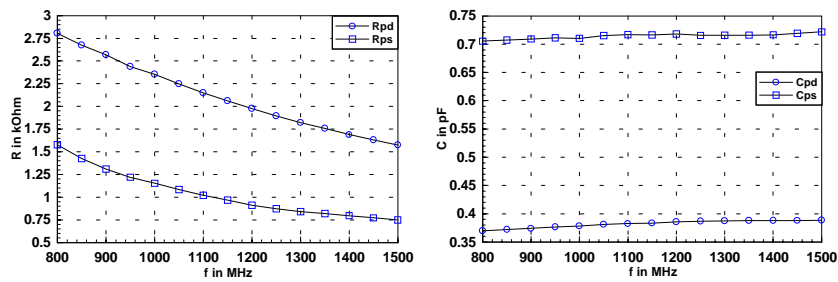

2.4.5 Modulator Output E/EX

Circuit for measurement:

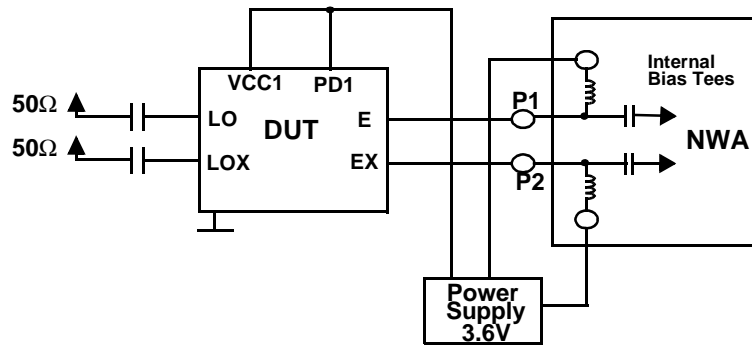

Modulator Output E/EX S-Parameters:

f	S11		S21		S12		S22	
MHz	MAG	ANG	MAG	ANG	MAG	ANG	MAG	ANG
800	0.978	-22.7	0.095	66.7	0.110	68.1	0.975	-22.5
850	0.976	-24.5	0.101	64.3	0.117	66.6	0.977	-24.2
900	0.975	-26.3	0.106	61.6	0.124	63.5	0.977	-25.7
950	0.970	-28.0	0.107	59.2	0.127	61.0	0.976	-27.7
1000	0.969	-29.6	0.109	58.9	0.130	58.4	0.971	-29.5
1050	0.965	-31.5	0.112	57.1	0.135	55.5	0.969	-31.4
1100	0.963	-33.4	0.114	57.7	0.135	52.4	0.966	-33.4
1150	0.960	-35.2	0.118	56.5	0.137	51.0	0.960	-35.1
1200	0.953	-37.1	0.123	55.7	0.136	49.0	0.956	-36.7
1250	0.950	-38.9	0.124	53.2	0.138	47.5	0.953	-38.6
1300	0.942	-40.6	0.128	52.2	0.138	47.0	0.950	-40.3
1350	0.935	-42.5	0.130	50.1	0.139	45.8	0.947	-42.2
1400	0.933	-44.1	0.132	48.5	0.142	44.0	0.945	-44.1
1450	0.927	-45.8	0.133	47.3	0.143	43.4	0.943	-45.9
1500	0.920	-47.7	0.136	46.0	0.145	41.4	0.941	-47.8

Modulator Output E/EX Impedances:

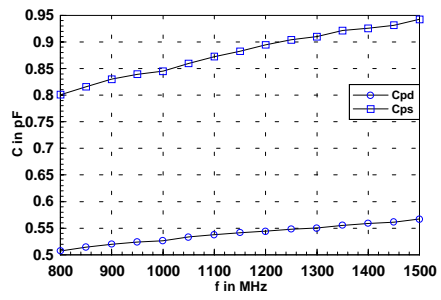
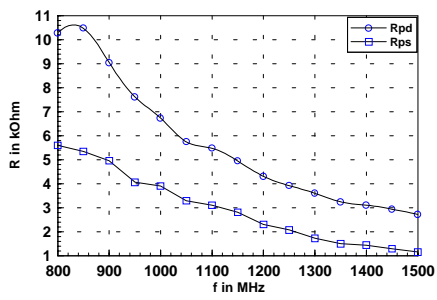

2.5 Circuits

2.5.1 Test Circuit 1

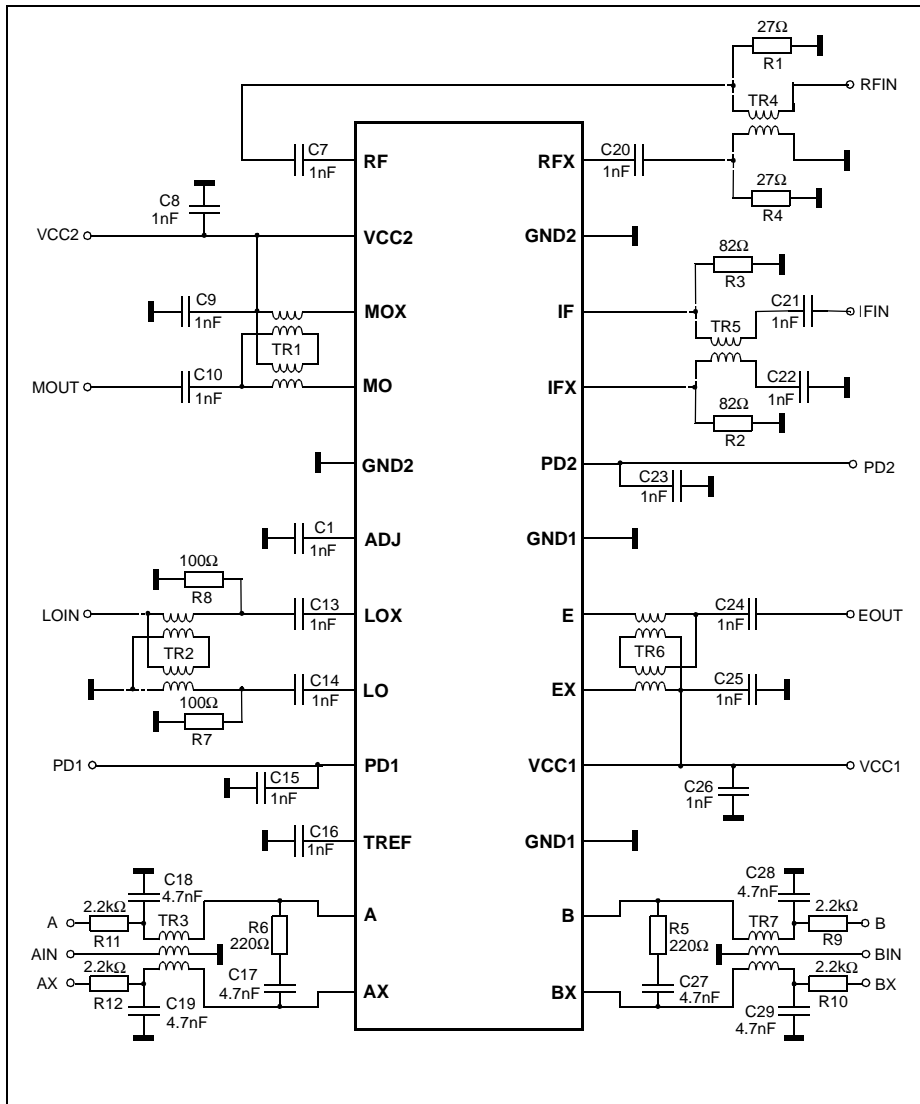

2.5.2 Application Circuit

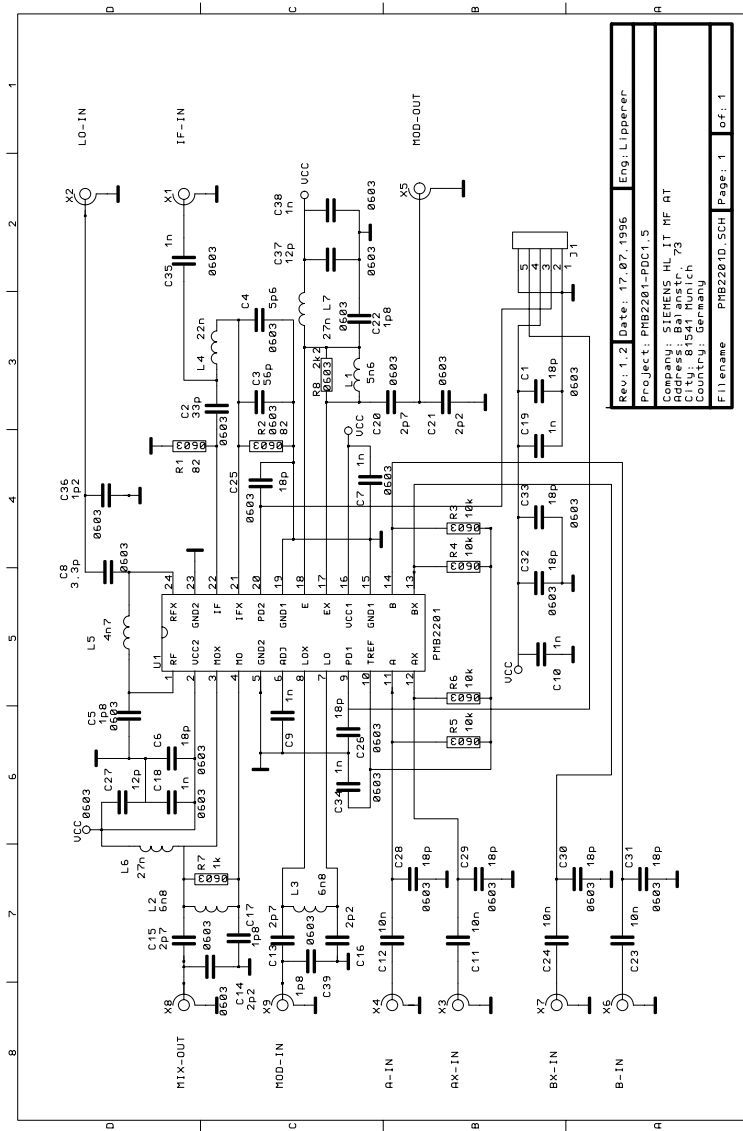

Rev: 1.2	Date: 17.07.1996	Eng. L. J. Pappeler
Project: PHB2201-PDC1.5		
Company: SIEMENS HL IT HF AT		
Address: Balanstr. 73		
D-91051 Erlangen		
Country: Germany		
Filename: PHB2201D_SCH	Page: 1	of: 1

The application circuit is designed for the following frequencies:

**Mixer section:**

$f_{\text{IF-IN}}$  : 178 MHz

$f_{\text{LO-IN}}$  : 1607 MHz - 1631 MHz

$f_{\text{MIX-OUT}}$  : 1429 MHz - 1453 MHz

**Modulator section:**

$f_{\text{MOD-IN}}$  = 1429MHz - 1453MHz

$f_{\text{MOD-OUT}}$  = 1429MHz - 1453MHz



## Looking for pricing, stock, or lifecycle information?

Click below to explore more details on WIN SOURCE:

- ⊖ [View PMB2201R-V12TR on WIN SOURCE](#)
- ⊖ [Infineon Technologies Information](#)

## Optimize Your Supply Chain with WIN SOURCE Solutions

- ✓ Global Sourcing Solution
- ✓ Obsolete Management
- ✓ Cost Control Management
- ✓ Shortage Management
- ✓ Alternative Solution
- ✓ Excess Inventory Management