



**THE DATASHEET OF
SG1536T**



High-Voltage Operational Amplifier

Description

The SG1536 series of monolithic amplifiers is designed specifically for use in high voltage applications up to ± 40 V and where high common-mode input ranges, high output voltage swings, and low input currents are required. These devices are internally compensated and are pin compatible with industry standard operational amplifiers.

Features

- High Supply Voltage Capability
- High Output Voltage Swing
- High Common-mode Voltage Range
- Internal Frequency Compensation
- Input Current 35 nA Maximum Over Temperature

High Reliability Features

- Available to MIL-STD – 883, 1.2.1
- MSC-AMS level “S” Processing Available
- Available to DSCC

Circuit Schematic

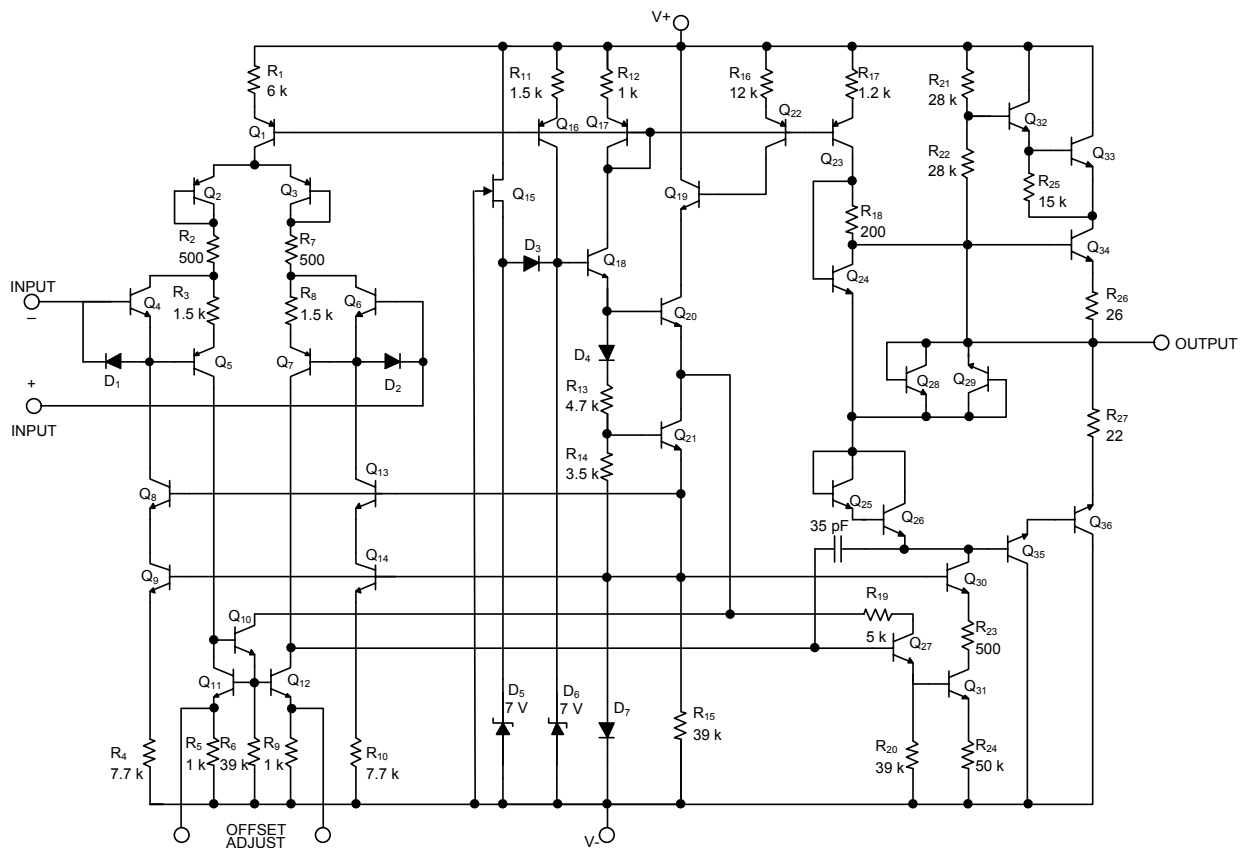

Figure 1 · Circuit Schematic

Connection Diagrams and Ordering Information

Ambient Temperature	Type	Package	Part Number	Packaging Type	Connection Diagram
-55°C to 125°C	T	8-pin metal can	SG1536T-883B	TO-99	
			SG1536T-DESC		
			SG1536T		
-55°C to 125°C	Y	8-pin ceramic DUAL INLINE PACKAGING	SG1536Y-883B	CERDIP	
			SG1536Y-DESC		
			SG1536Y		
Notes: <ol style="list-style-type: none"> Contact factory for DESC product availability. All packages are viewed from the top. Hermetic Packages T, & Y use Sn63/ Pb37 hot solder lead finish, contact factory for availability of RoHS versions. 					

Absolute Maximum Ratings

Parameter	Value	Units
Supply Voltage	±40	V
Differential Input Signal	$\pm(V^+ + V^- - 3)$	V
Common-Mode Input Swing	$+V^+, -(V^- - 3)$	V
Output Short Circuit Duration ($V^+ = V^- = 28\text{ V}$, $V_O = 0\text{ V}$)	5	s
Operating Junction Temperature		
Hermetic (T, Y Packages)	150	°C
Storage Temperature Range	-65 to 150	°C
Lead Temperature (Soldering, 10 seconds)	300	°C
Note: Exceeding these ratings could cause damage to the device.		

Thermal Data

Parameter	Value	Units
T Package		
Thermal Resistance-Junction to Case, θ_{JC}	25	$^{\circ}C/W$
Thermal Resistance-Junction to Ambient, θ_{JA}	130	$^{\circ}C/W$
Y Package		
Thermal Resistance-Junction to Case, θ_{JC}	50	$^{\circ}C/W$
Thermal Resistance-Junction to Ambient, θ_{JA}	130	$^{\circ}C/W$
Notes: 1. Junction Temperature Calculation: $T_J = T_A + (P_D \times \theta_{JA})$. 2. The above numbers for θ_{JC} are maximums for the limiting thermal resistance of the package in a standard mounting configuration. The θ_{JA} numbers are meant to be guidelines for the thermal performance of the device/pc-board system. All of the above assume no ambient airflow.		

Recommended Operating Conditions

Parameter	Value	Units
Supply Voltage Range		
SG1536	± 12 to ± 36	V
Operating Ambient Temperature Range		
SG1536	-55 to 125	$^{\circ}C$
Note: Range over which the device is functional.		

Electrical Characteristics

Unless otherwise specified, these specifications apply over the operating ambient $T_A = 25^\circ\text{C}$ and $V_S = \pm 28\text{ V}$. Low duty cycle pulse testing techniques are used that maintains junction and case temperatures equal to the ambient temperature.

Parameter	Test Conditions	SG1536			Units
		Min	Typ	Max	
Input Offset Voltage			2.0	5.0	mV
	$T_A = T_{\text{MIN}}$ to T_{MAX}			7.0	mV
Input Offset Current			1.0	3.0	nA
	$T_A = T_{\text{MIN}}$			7.0	nA
	$T_A = T_{\text{MAX}}$			4.5	nA
Input Bias Current			8.0	20	nA
	$T_A = T_{\text{MIN}}$ to T_{MAX}			35	nA
Differential Input Impedance	Open loop, $\leq 5.0\text{ Hz}$		10		$\text{M}\Omega$
Common-Mode Input Impedance	$f \leq 5.0\text{ Hz}$		250		$\text{M}\Omega$
Common-Mode Input Voltage Range (Peak)		± 24	± 25		V
Common-Mode Rejection Ratio		80	110		dB
Large Signal Voltage Gain	$R_L = 10\text{ k}\Omega$, $V_O = \pm 10\text{ V}$		200 k		V/V
	$R_L = 100\text{ k}\Omega$, $V_O = \pm 10\text{ V}$	100 k	500 k		V/V
	$T_A = T_{\text{MIN}}$ to T_{MAX}	50 k			V/V
Power Supply Rejection Ratio	V^- constant, $R_S \leq 10\text{ k}\Omega$		15	100	$\mu\text{V/V}$
	V^+ constant, $R_S \leq 10\text{ k}\Omega$		15	100	$\mu\text{V/V}$
Output Impedance	$f \leq 5.0\text{ Hz}$		1.0		$\text{k}\Omega$
Short Circuit Output Current			± 17		mA
Output Voltage Swing (Peak)	$R_L = 5.0\text{ k}\Omega$, $V_S = \pm 28\text{ V}$	± 22			V
	$R_L = 5.0\text{ k}\Omega$, $V_S = \pm 36\text{ V}$	± 30			V
Power Bandwidth	$A = +1$, $R_L = 5\text{ k}\Omega$, THD $\leq 5\%$, $V_O = 40\text{ V}_{\text{p-p}}$		23		kHz
Unity Gain Crossover Frequency	Open loop		1.0		MHz
Slew Rate	Unity gain		2.0		V/ μs
Phase Margin	Open loop, unity gain		50		deg
Gain Margin			18		dB

Electrical Characteristics (continued)

Parameter	Test Conditions	SG1536			Units
		Min	Typ	Max	
Equivalent Input Noise	$A_v = 100$, $R_s = 10\text{ k}\Omega$, $f = 1.0\text{ kHz}$, $BW = 1.0\text{ Hz}$		50		nV/ $\sqrt{\text{Hz}}$
Power Supply Current	(Note)		2.2	4.0	mA
Power Consumption	$V_o = 0$, $V_s = \pm 36\text{ V}$		124	224	mW

Note: $V_{CC} = V_{EE} = 36\text{ V}$ for SG1536. $V_{CC} = V_{EE} = 28\text{ V}$ for SG1436.

Characteristic Curves

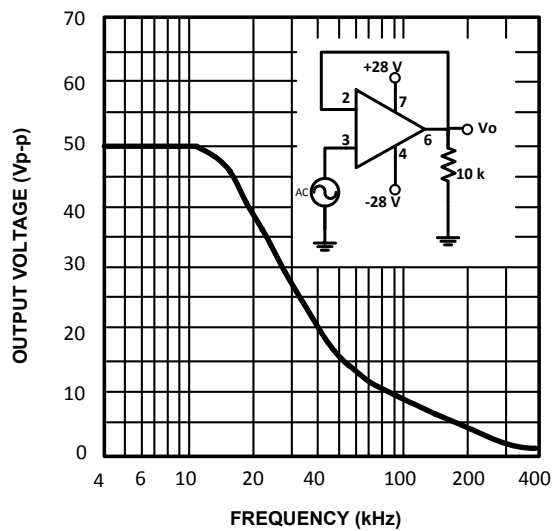

Figure 2 · Power Bandwidth

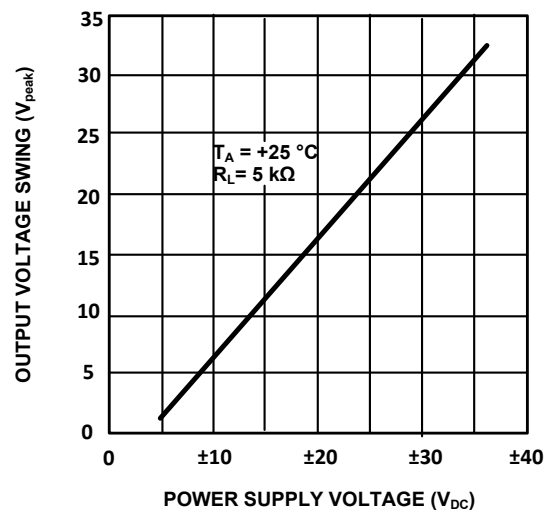

Figure 3 · Peak Output Voltage Swing vs. Power Supply Voltage

Characteristic Curves (continued)

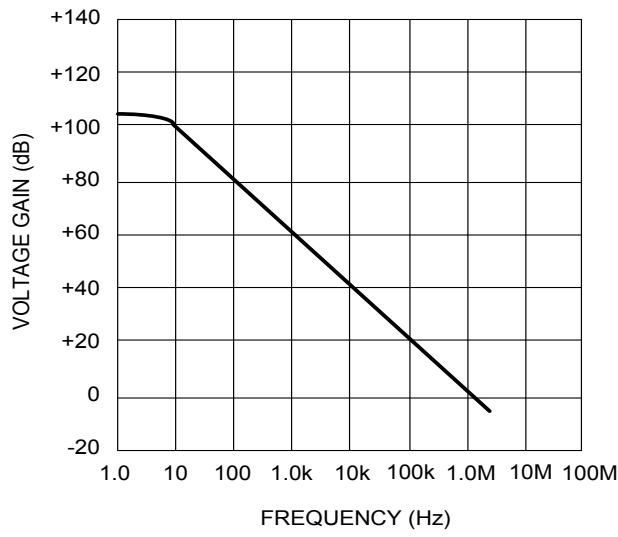

Figure 4 · Open-loop Frequency Response

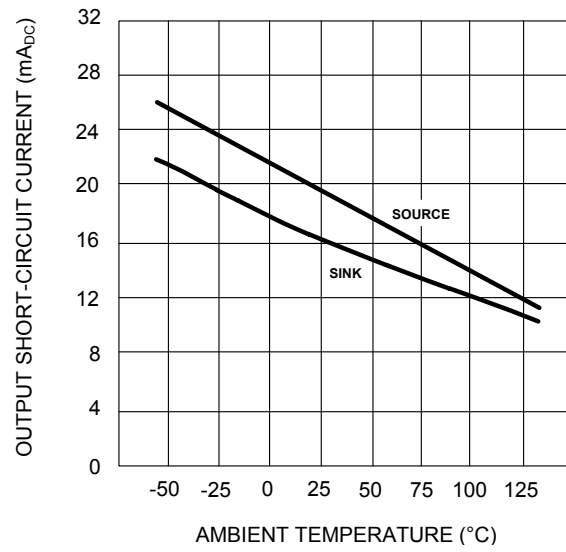

Figure 5 · Output Short-Circuit Current vs. Temperature

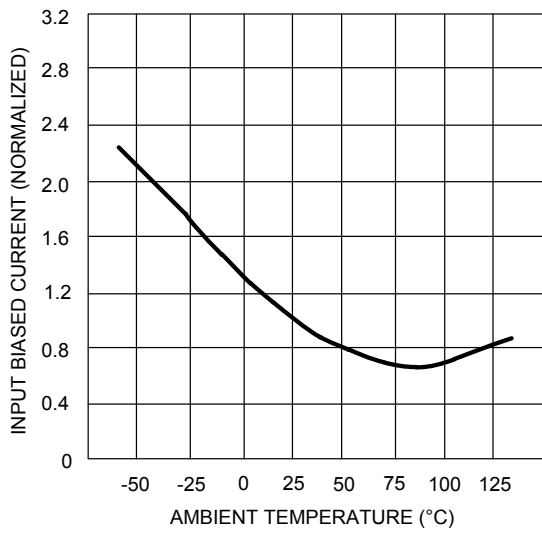

Figure 6 · Input Bias Current vs. Temperature

Application Information

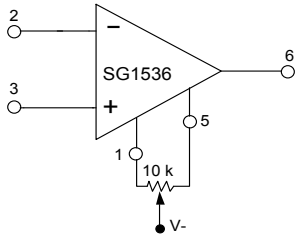

Figure 7 · Voltage Offset Null Circuit

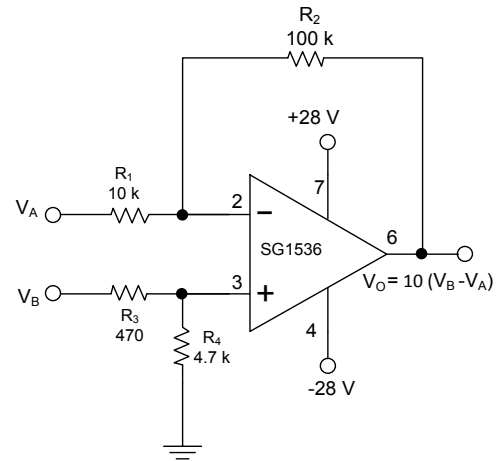

Figure 8 · Differential Amplifier With ± 20 V Common-Mode Input Voltage Range

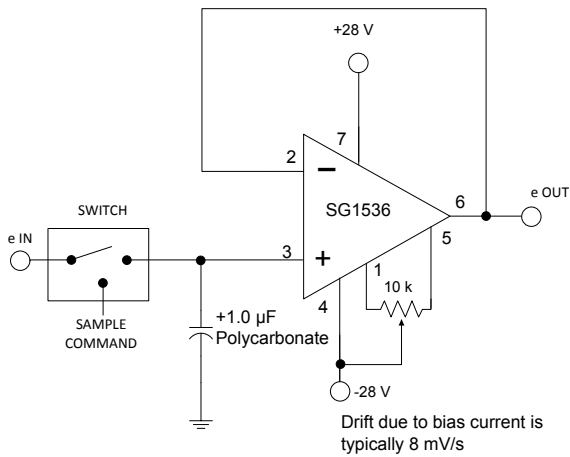

Figure 9 · Low-Drift Sample and Hold

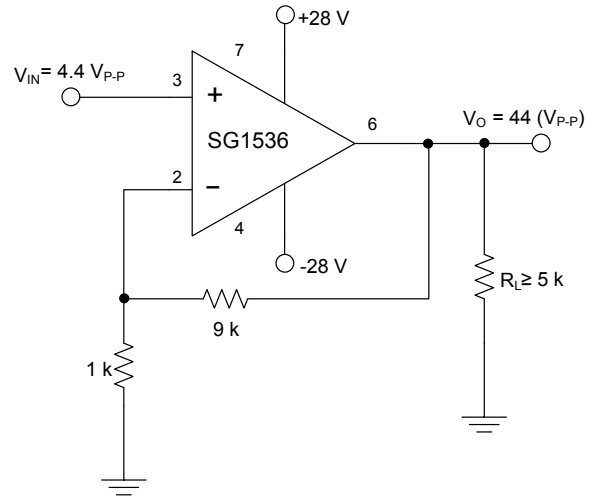

Figure 10 · Typical Non-inverting $\times 10$ Voltage Amplifier

Application Information (continued)

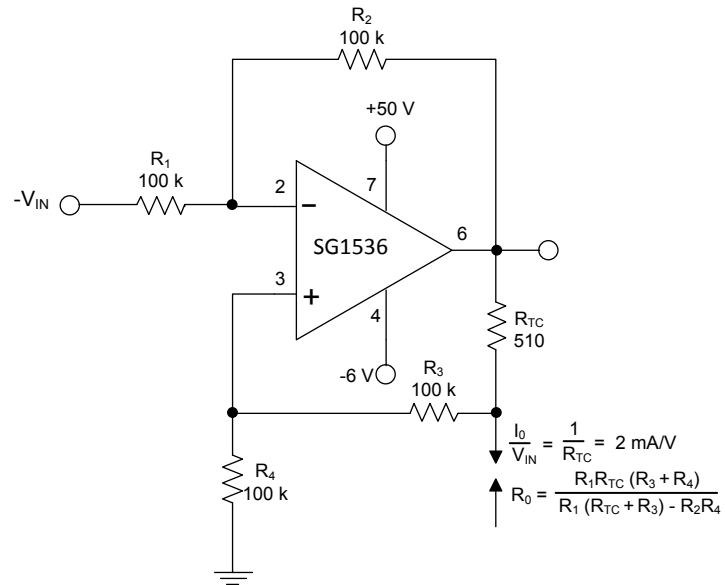
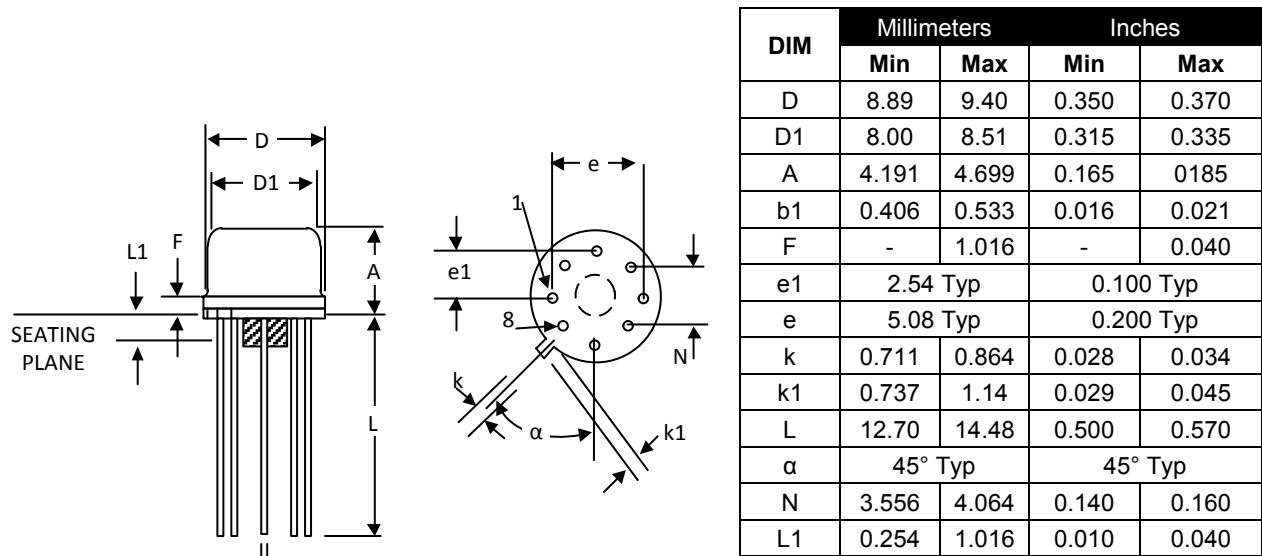

Figure 11 · Voltage Controlled Current Source or Trans-conductance Amplifier with 0 V to 40 V Compliance

Package Outline Dimensions



Note:
 Dimensions do not include protrusions; these shall not exceed 0.155 mm (0.006") on any side. Lead dimension shall not include solder coverage.

Figure 12 · T 8-Pin Metal Can TO-99

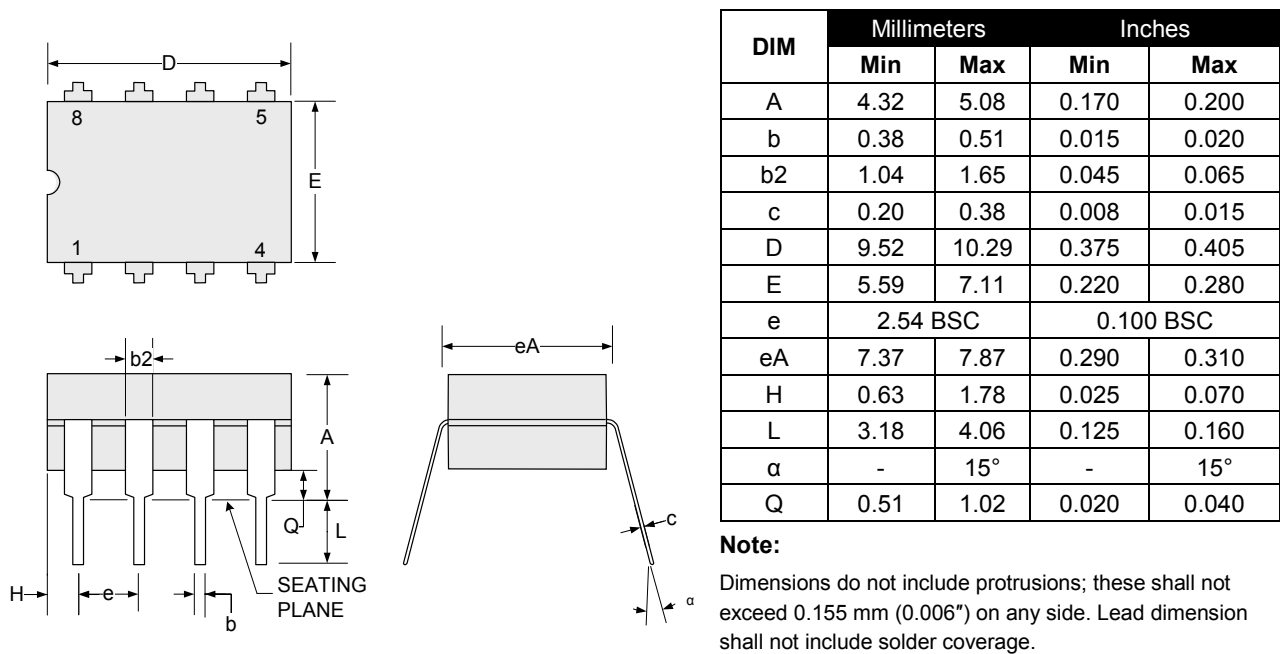

Note:
 Dimensions do not include protrusions; these shall not exceed 0.155 mm (0.006") on any side. Lead dimension shall not include solder coverage.

Figure 13 · Y 8-Pin Cerdip Package Dimensions



Microsemi Corporate Headquarters
One Enterprise, Aliso Viejo,
CA 92656 USA

Within the USA: +1 (800) 713-4113
Outside the USA: +1 (949) 380-6100
Sales: +1 (949) 380-6136
Fax: +1 (949) 215-4996

E-mail: sales.support@microsemi.com

© 2015 Microsemi Corporation. All rights reserved. Microsemi and the Microsemi logo are trademarks of Microsemi Corporation. All other trademarks and service marks are the property of their respective owners.

Microsemi Corporation (MSCC) offers a comprehensive portfolio of semiconductor and system solutions for communications, defense & security, aerospace and industrial markets. Products include high-performance and radiation-hardened analog mixed-signal integrated circuits, FPGAs, SoCs and ASICs; power management products; timing and synchronization devices and precise time solutions, setting the world's standard for time; voice processing devices; RF solutions; discrete components; security technologies and scalable anti-tamper products; Ethernet solutions; Power-over-Ethernet ICs and midspans; as well as custom design capabilities and services. Microsemi is headquartered in Aliso Viejo, Calif., and has approximately 3,600 employees globally. Learn more at www.microsemi.com.

Microsemi makes no warranty, representation, or guarantee regarding the information contained herein or the suitability of its products and services for any particular purpose, nor does Microsemi assume any liability whatsoever arising out of the application or use of any product or circuit. The products sold hereunder and any other products sold by Microsemi have been subject to limited testing and should not be used in conjunction with mission-critical equipment or applications. Any performance specifications are believed to be reliable but are not verified, and Buyer must conduct and complete all performance and other testing of the products, alone and together with, or installed in, any end-products. Buyer shall not rely on any data and performance specifications or parameters provided by Microsemi. It is the Buyer's responsibility to independently determine suitability of any products and to test and verify the same. The information provided by Microsemi hereunder is provided "as is, where is" and with all faults, and the entire risk associated with such information is entirely with the Buyer. Microsemi does not grant, explicitly or implicitly, to any party any patent rights, licenses, or any other IP rights, whether with regard to such information itself or anything described by such information. Information provided in this document is proprietary to Microsemi, and Microsemi reserves the right to make any changes to the information in this document or to any products and services at any time without notice.

Looking for pricing, stock, or lifecycle information?

Click below to explore more details on WIN SOURCE:

- ⊖ [View SG1536T on WIN SOURCE](#)
- ⊖ [Microchip Technology](#) Information

Optimize Your Supply Chain with WIN SOURCE Solutions

- ✓ Global Sourcing Solution
- ✓ Obsolete Management
- ✓ Cost Control Management
- ✓ Shortage Management
- ✓ Alternative Solution
- ✓ Excess Inventory Management