

Gallium Arsenide PHEMT

RF Power Field Effect Transistor

Designed for WiMAX and WLL base station applications that have a 200 MHz BW requirement in the 2300–3800 MHz frequency range. Suitable for TDMA and CDMA amplifier applications. To be used in Class AB applications.

- Typical WiMAX Performance: $V_{DD} = 12$ Volts, $I_{DQ} = 300$ mA, $P_{out} = 2$ Watts Avg., $f = 3500$ MHz, 802.16d, 64 QAM $3/4$, 4 bursts, 7 MHz Channel Bandwidth, Input Signal PAR = 9.5 dB @ 0.01% Probability on CCDF.
 - Power Gain — 11.5 dB
 - Drain Efficiency — 22%
 - RCE — -33 dB
 - Meets ETSI Type G Mask
- 20 Watts P1dB @ 3500 MHz, CW

Features

- Supports up to 28 MHz Bandwidth OFDM Signals
- Internally Input Matched for Ease of Use
- High Gain, High Efficiency and High Linearity
- Excellent Thermal Stability
- RoHS Compliant
- In Tape and Reel. R1 Suffix = 500 Units per 32 mm, 13 inch Reel.

MRFG35020AR1

**3.5 GHz, 20 W, 12 V
WiMAX
POWER FET
GaAs PHEMT**

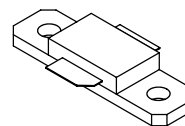

**CASE 360E-01, STYLE 2
NI-360 SHORT LEAD**

Table 1. Maximum Ratings

Rating	Symbol	Value	Unit
Drain-Source Voltage	V_{DSS}	15	Vdc
Gate-Source Voltage	V_{GS}	-5	Vdc
RF Input Power	P_{in}	34	dBm
Storage Temperature Range	T_{stg}	-40 to +150	°C
Channel Temperature (1)	T_{ch}	175	°C

Table 2. Thermal Characteristics

Characteristic	Symbol	Value (2)	Unit
Thermal Resistance, Junction to Case	$R_{\theta JC}$	2.7	°C/W

1. For reliable operation, the operating channel temperature should not exceed 150°C. Exceeding 150°C channel operating temperature may result in device performance degradation.
2. Refer to AN1955, *Thermal Measurement Methodology of RF Power Amplifiers*. Go to <http://www.freescale.com/rf>. Select Documentation/Application Notes - AN1955.

LIFETIME BUY

LAST SHIP 30 JUN 12
LAST ORDER 1 JUL 11

Table 3. ESD Protection Characteristics

Test Methodology	Class
Human Body Model (per JESD22-A114)	2 (Minimum)
Machine Model (per EIA/JESD22-A115)	A (Minimum)
Charge Device Model (per JESD22-C101)	IV (Minimum)

Table 4. Electrical Characteristics ($T_C = 25^\circ\text{C}$ unless otherwise noted)

Characteristic	Symbol	Min	Typ	Max	Unit
DC Characteristics					
Off State Drain Current ($V_{DS} = 3.5\text{ Vdc}$, $V_{GS} = -2.2\text{ Vdc}$)	I_{DSO}	—	10	425	μAdc
Off State Current ($V_{DS} = 28.5\text{ Vdc}$, $V_{GS} = -2.5\text{ Vdc}$)	I_{DSX}	—	2	42.5	mAdc
Gate-Source Cut-off Voltage ($V_{DS} = 3.5\text{ Vdc}$, $I_{DS} = 42.5\text{ mA}$)	$V_{GS(th)}$	-1.2	-0.95	-0.7	Vdc

Functional Tests (In Freescale Test Fixture, 50 ohm system) ⁽¹⁾ $V_{DD} = 12\text{ Vdc}$, $I_{DQ} = 300\text{ mA}$, $P_{out} = 2\text{ W Avg.}$, $f = 3500\text{ MHz}$, Single-Carrier W-CDMA, 3.84 MHz Channel Bandwidth Carrier. ACPR measured in 3.84 MHz Channel Bandwidth @ $\pm 5\text{ MHz}$ Offset. PAR = 8.5 dB @ 0.01% Probability on CCDF.

Power Gain	G_{ps}	9.5	11.5	—	dB
Drain Efficiency	η_D	18	22	—	%
Adjacent Channel Power Ratio	ACPR	—	-43	-39	dBc

Typical RF Performance (In Freescale Test Fixture, 50 ohm system) $V_{DD} = 12\text{ Vdc}$, $I_{DQ} = 300\text{ mA}$, $f = 3500\text{ MHz}$

Output Power, 1 dB Compression Point, CW	P1dB	—	20	—	W
--	------	---	----	---	---

1. Measurements made with device in test fixture.

LIFETIME BUY

LAST ORDER 1 JUL 11 LAST SHIP 30 JUN 12

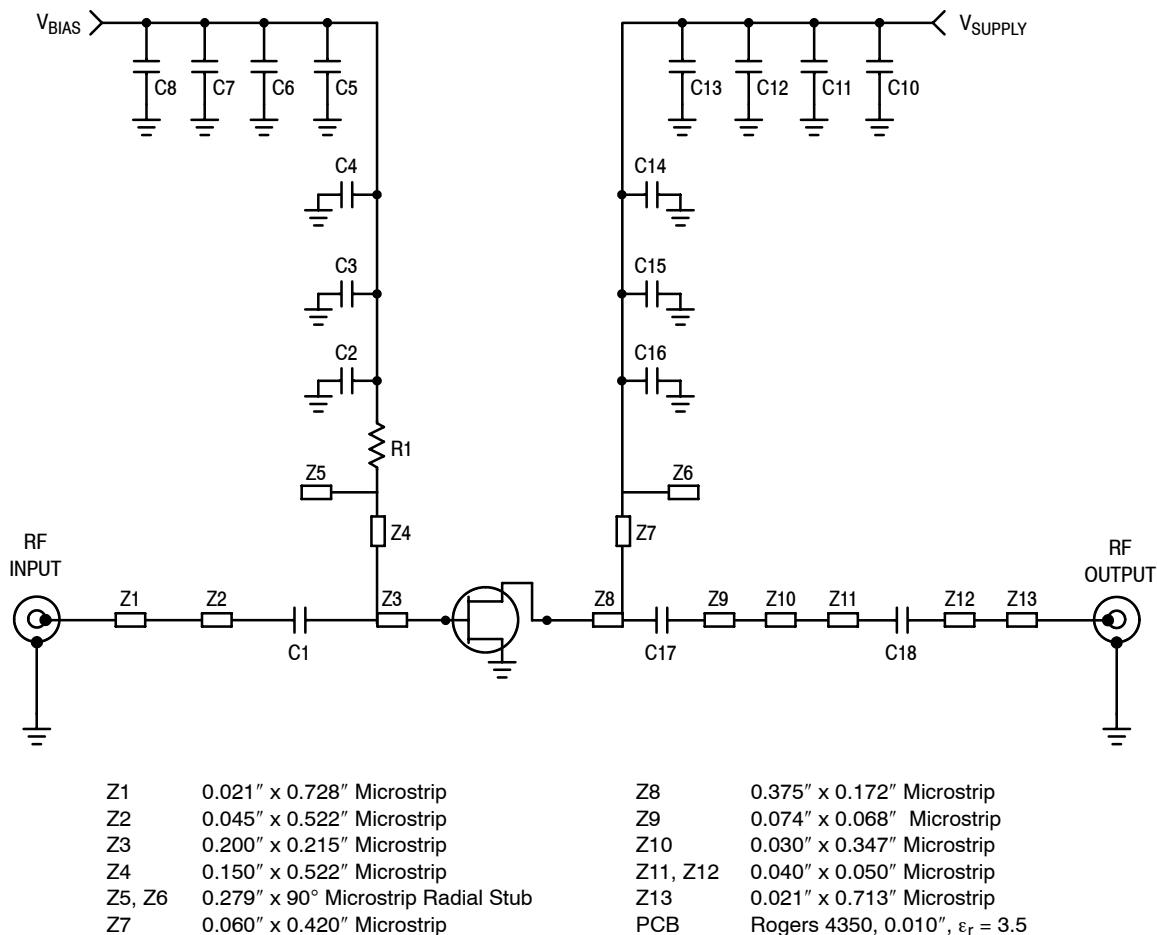

Figure 1. MRFG35020A Test Circuit Schematic

Table 5. MRFG35020A Test Circuit Component Designations and Values

Part	Description	Part Number	Manufacturer
C1	3.9 pF Chip Capacitor	08051J3R9BBS	AVX
C2, C16	10 pF Chip Capacitors	ATC100A100JT150XT	ATC
C3, C15	100 pF Chip Capacitors	ATC100A101JT150XT	ATC
C4, C14	100 pF Chip Capacitors	ATC100B101JT500XT	ATC
C5, C13	1000 pF Chip Capacitors	ATC100B102JT50XT	ATC
C6, C12	0.01 μ F Chip Capacitors	ATC200B103KT50XT	ATC
C7, C11	39K pF Chip Capacitors	ATC200B393KT50XT	ATC
C8, C10	10 μ F Chip Capacitors	GRM55DR61H106KA88B	Murata
C9	None		
C17	1.8 pF Chip Capacitors	08051J1R8BBS	AVX
C18	1.5 pF Chip Capacitor	08051J1R5BBS	AVX
R1	6.2 Ω , 1/4 W Chip Resistor	CRCW12066R20FKEA	Vishay

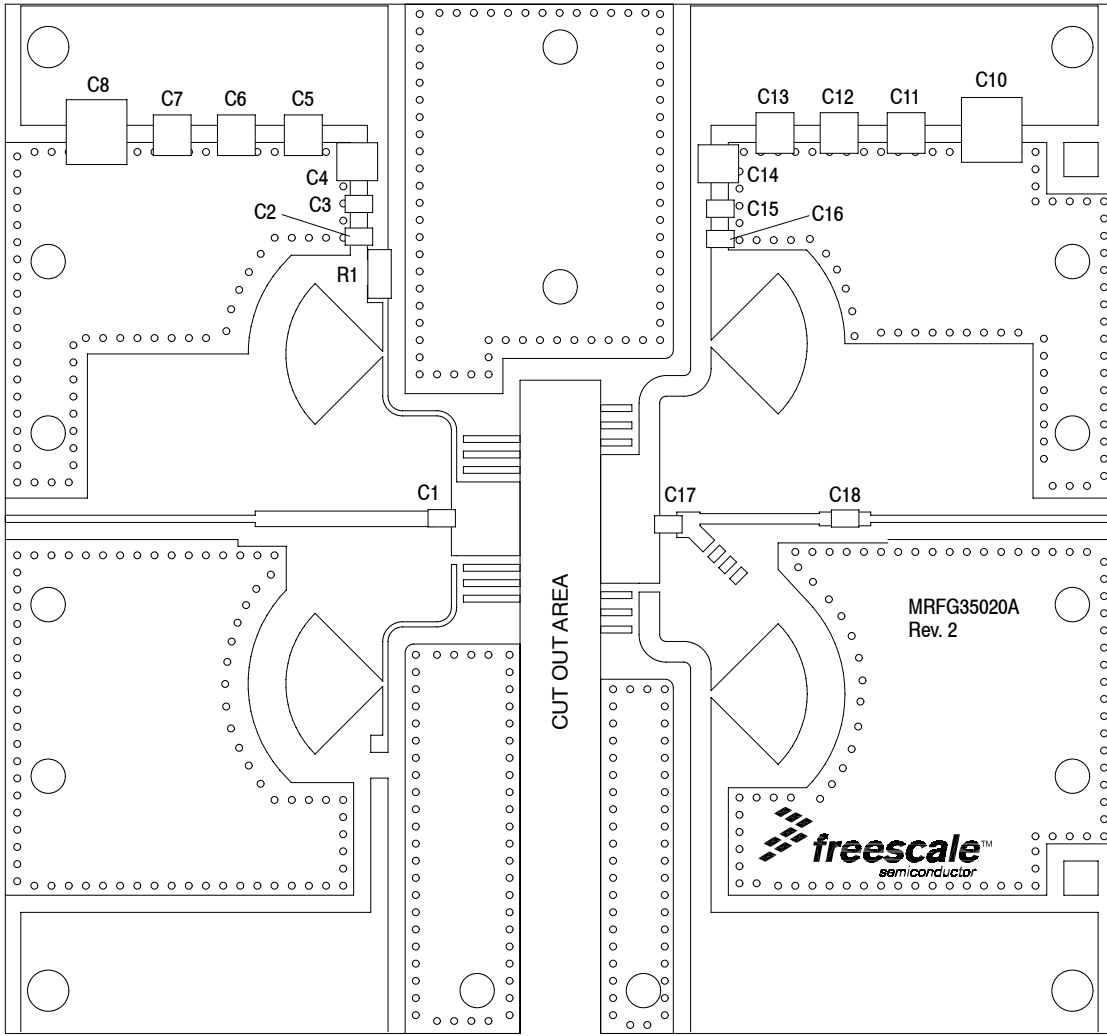

Figure 2. MRF35020A Test Circuit Component Layout

TYPICAL CHARACTERISTICS

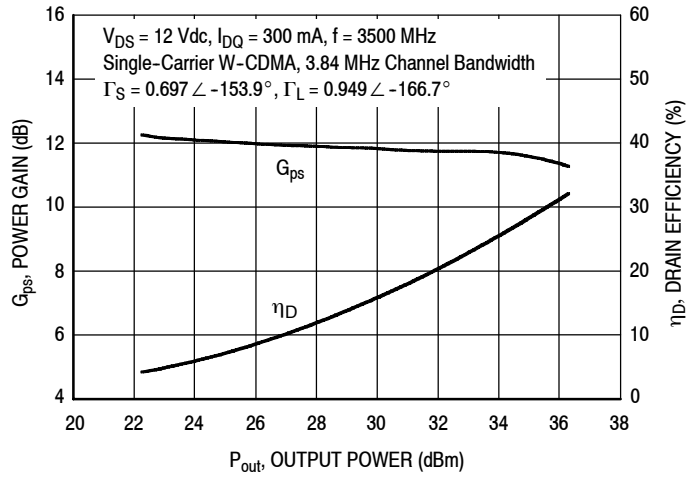

Figure 3. Single-Channel W-CDMA Power Gain and Drain Efficiency versus Output Power

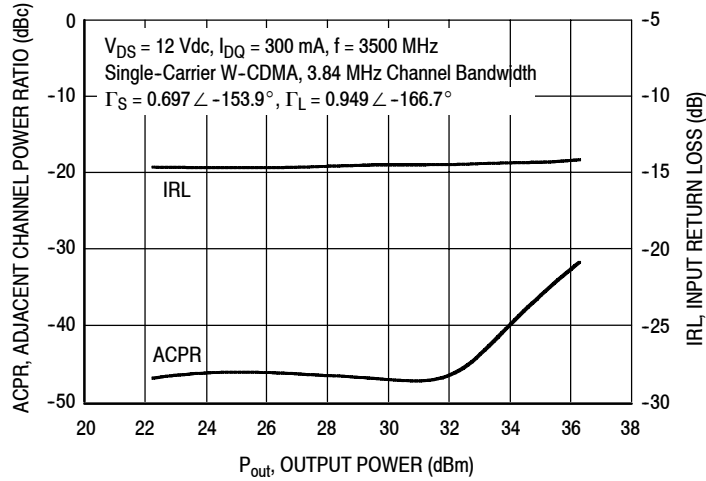

Figure 4. Single-Channel W-CDMA Adjacent Channel Power Ratio and IRL versus Output Power

NOTE: All data is referenced to package lead interface. Γ_S and Γ_L are the impedances presented to the DUT. All data is generated from load pull, not from the test circuit shown.

LIFETIME BUY

LAST ORDER 1 JUL 11 LAST SHIP 30 JUN 12

TYPICAL CHARACTERISTICS

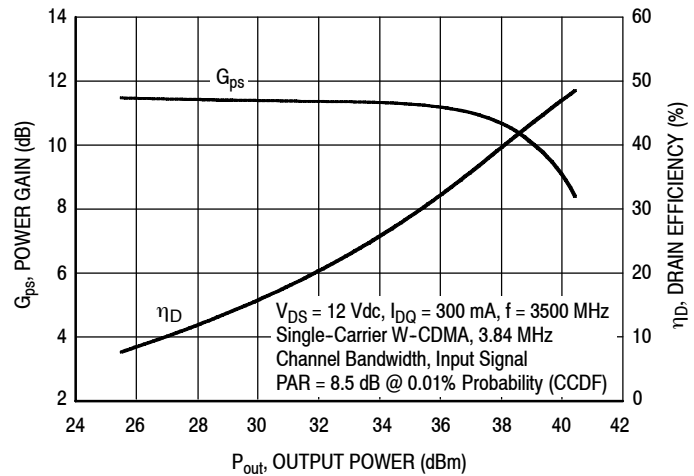

Figure 5. Single-Channel W-CDMA Power Gain and Drain Efficiency versus Output Power

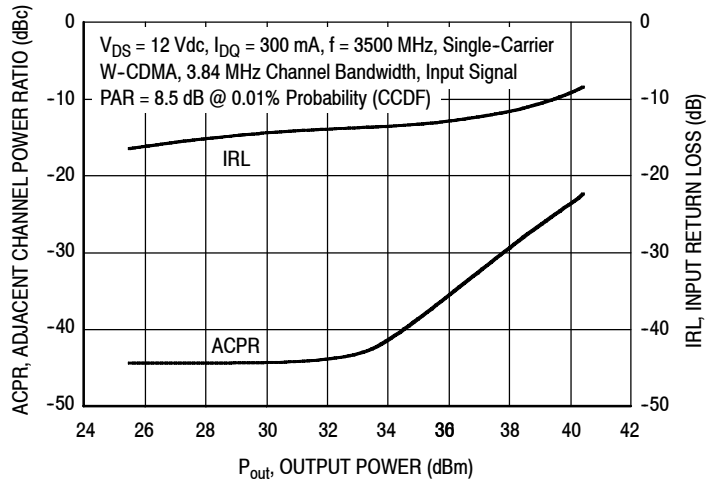

Figure 6. Single-Channel W-CDMA Adjacent Channel Power Ratio and IRL versus Output Power

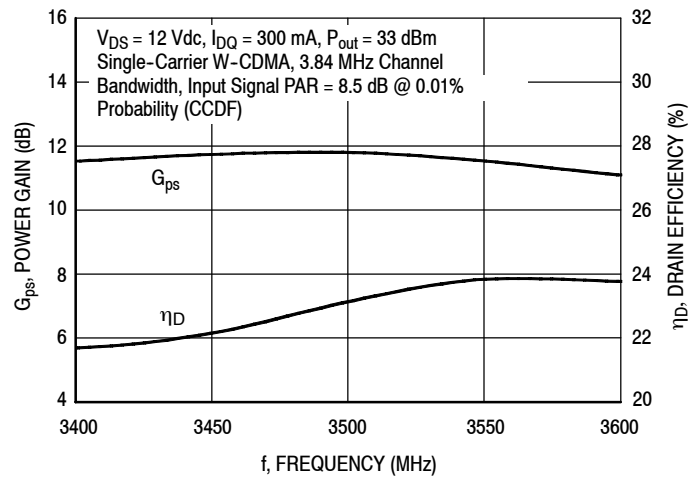

Figure 7. Single-Channel W-CDMA Power Gain and Drain Efficiency versus Frequency

NOTE: Data is generated from the test circuit shown.

TYPICAL CHARACTERISTICS

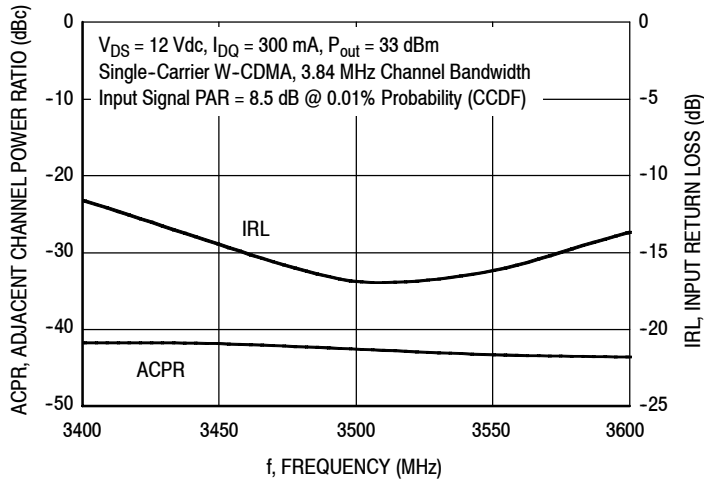

Figure 8. Single-Channel W-CDMA Adjacent Channel Power Ratio and IRL versus Frequency

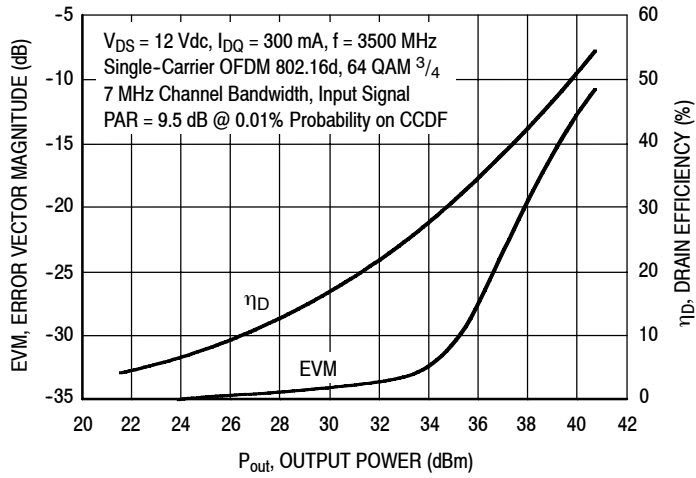
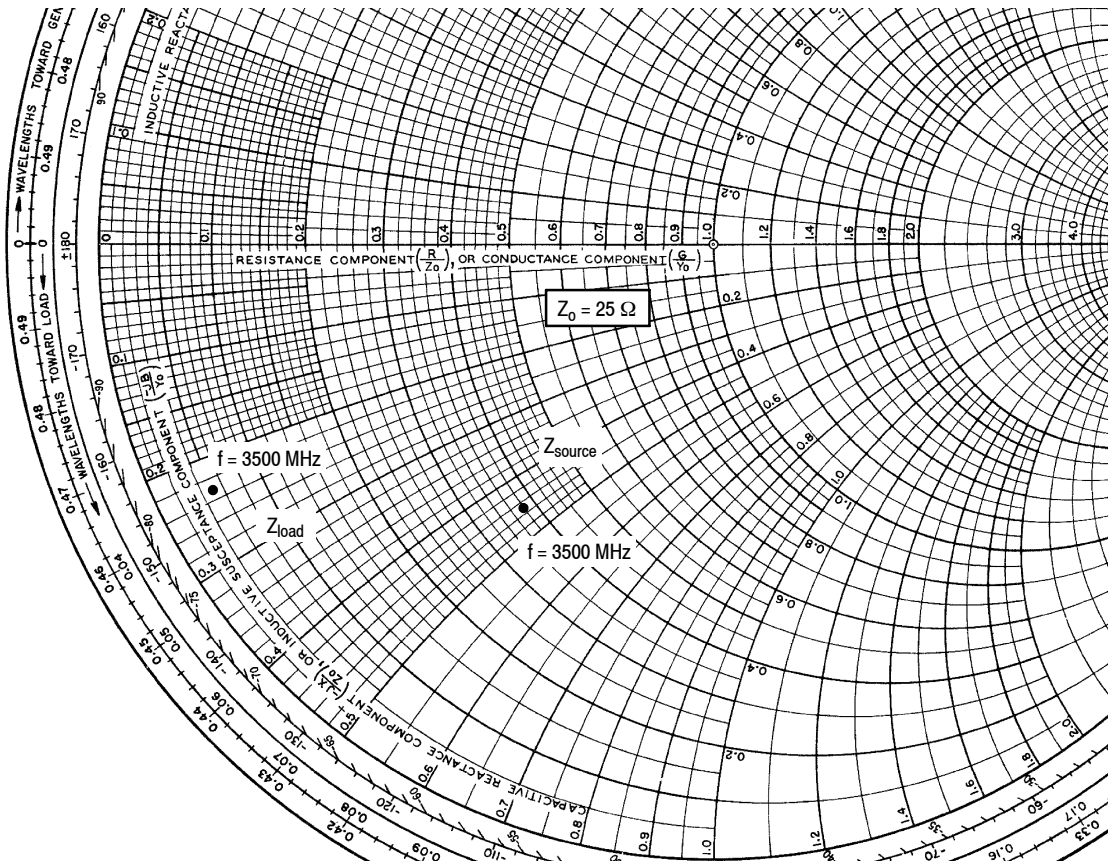

Figure 9. Single-Channel OFDM Error Vector Magnitude and Drain Efficiency versus Output Power

NOTE: Data is generated from the test circuit shown.

LIFETIME BUY

LAST ORDER 1 JUL 11 LAST SHIP 30 JUN 12



$V_{DD} = 12 \text{ Vdc}$, $I_{DQ} = 300 \text{ mA}$, $P_{out} = 2 \text{ W Avg.}$

f MHz	Z _{source} Ω	Z _{load} Ω
3500	9.4 - j11.2	1.3 - j5.8

Z_{source} = Test circuit impedance as measured from gate to ground.

Z_{load} = Test circuit impedance as measured from drain to ground.

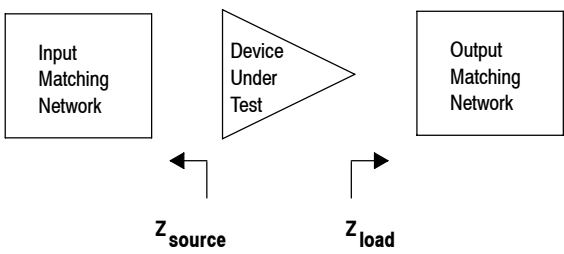
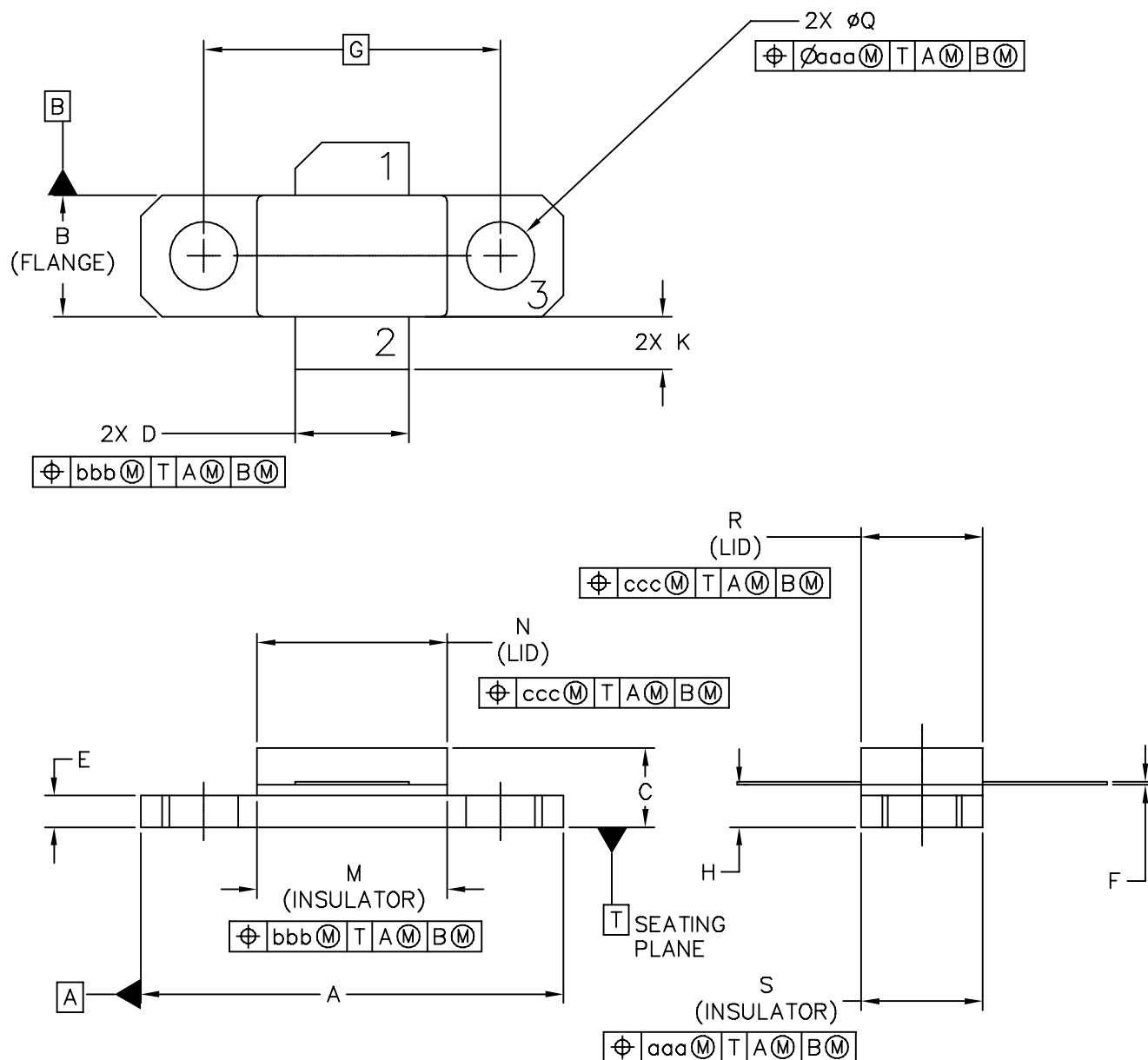

Figure 10. Series Equivalent Source and Load Impedance

PACKAGE DIMENSIONS



© FREESCALE SEMICONDUCTOR, INC. ALL RIGHTS RESERVED.	MECHANICAL OUTLINE	PRINT VERSION NOT TO SCALE	
TITLE: NI-360 SHORT LEAD	DOCUMENT NO: 98ASA10715D	REV: A	
	CASE NUMBER: 360E-01	03 APR 2006	
	STANDARD: NON-JEDEC		

NOTES:

1. INTERPRET DIMENSIONS AND TOLERANCES PER ASME Y14.5M-1994.
2. CONTROLLING DIMENSION: INCH
3. DIMENSION H IS MEASURED .030 AWAY FROM PACKAGE BODY

STYLE 1:

- PIN 1 - DRAIN
- 2 - GATE
- 3 - SOURCE

STYLE 2:

- PIN 1 - GATE
- 2 - DRAIN
- 3 - SOURCE

DIM	INCH		MILLIMETER		DIM	INCH		MILLIMETER	
	MIN	MAX	MIN	MAX		MIN	MAX	MIN	MAX
A	.795	.805	20.19	20.45	N	.357	.363	9.07	9.22
B	.225	.235	5.72	5.97	Q	.125	.135	3.18	3.43
C	.125	.175	3.18	4.45	R	.227	.233	5.77	5.92
D	.210	.220	5.33	5.59	S	.225	.235	5.72	5.97
E	.055	.065	1.40	1.65					
F	.004	.006	0.10	0.15	aaa		.005		0.13
G	.562 BSC		14.28 BSC		bbb		.010		0.25
H	.077	.087	1.96	2.21	ccc		.015		0.38
K	.085	.115	2.16	2.92					
M	.355	.365	9.02	9.27					
© FREESCALE SEMICONDUCTOR, INC. ALL RIGHTS RESERVED.			MECHANICAL OUTLINE			PRINT VERSION NOT TO SCALE			
TITLE: NI-360 SHORT LEAD					DOCUMENT NO: 98ASA10715D			REV: A	
					CASE NUMBER: 360E-01			03 APR 2006	
					STANDARD: NON-JEDEC				

PRODUCT DOCUMENTATION

Refer to the following documents to aid your design process.

Application Notes

- AN1955: Thermal Measurement Methodology of RF Power Amplifiers

REVISION HISTORY

The following table summarizes revisions to this document.

Revision	Date	Description
0	Jan. 2008	<ul style="list-style-type: none"> • Initial Release of Data Sheet
1	Dec. 2008	<ul style="list-style-type: none"> • Changed Storage Temperature Range in Max Ratings table from -65 to +175 to -65 to +150 for standardization across products, p. 1 • Removed "Operating Case Temperature Range" from Maximum Ratings table so that the maximum channel temperature rating is the limiting thermal design criteria and not the case temperature range, p. 1

LIFETIME BUY

LAST ORDER 1 JUL 11 LAST SHIP 30 JUN 12

How to Reach Us:

Home Page:

www.freescale.com

Web Support:

<http://www.freescale.com/support>

USA/Europe or Locations Not Listed:

Freescale Semiconductor, Inc.
Technical Information Center, EL516
2100 East Elliot Road
Tempe, Arizona 85284
1-800-521-6274 or +1-480-768-2130
www.freescale.com/support

Europe, Middle East, and Africa:

Freescale Halbleiter Deutschland GmbH
Technical Information Center
Schatzbogen 7
81829 Muenchen, Germany
+44 1296 380 456 (English)
+46 8 52200080 (English)
+49 89 92103 559 (German)
+33 1 69 35 48 48 (French)
www.freescale.com/support

Japan:

Freescale Semiconductor Japan Ltd.
Headquarters
ARCO Tower 15F
1-8-1, Shimo-Meguro, Meguro-ku,
Tokyo 153-0064
Japan
0120 191014 or +81 3 5437 9125
support.japan@freescale.com

Asia/Pacific:

Freescale Semiconductor China Ltd.
Exchange Building 23F
No. 118 Jianguo Road
Chaoyang District
Beijing 100022
China
+86 10 5879 8000
support.asia@freescale.com

For Literature Requests Only:

Freescale Semiconductor Literature Distribution Center
P.O. Box 5405
Denver, Colorado 80217
1-800-441-2447 or +1-303-675-2140
Fax: +1-303-675-2150
LDCForFreescaleSemiconductor@hibbertgroup.com

Information in this document is provided solely to enable system and software implementers to use Freescale Semiconductor products. There are no express or implied copyright licenses granted hereunder to design or fabricate any integrated circuits or integrated circuits based on the information in this document.

Freescale Semiconductor reserves the right to make changes without further notice to any products herein. Freescale Semiconductor makes no warranty, representation or guarantee regarding the suitability of its products for any particular purpose, nor does Freescale Semiconductor assume any liability arising out of the application or use of any product or circuit, and specifically disclaims any and all liability, including without limitation consequential or incidental damages. "Typical" parameters that may be provided in Freescale Semiconductor data sheets and/or specifications can and do vary in different applications and actual performance may vary over time. All operating parameters, including "Typicals", must be validated for each customer application by customer's technical experts. Freescale Semiconductor does not convey any license under its patent rights nor the rights of others. Freescale Semiconductor products are not designed, intended, or authorized for use as components in systems intended for surgical implant into the body, or other applications intended to support or sustain life, or for any other application in which the failure of the Freescale Semiconductor product could create a situation where personal injury or death may occur. Should Buyer purchase or use Freescale Semiconductor products for any such unintended or unauthorized application, Buyer shall indemnify and hold Freescale Semiconductor and its officers, employees, subsidiaries, affiliates, and distributors harmless against all claims, costs, damages, and expenses, and reasonable attorney fees arising out of, directly or indirectly, any claim of personal injury or death associated with such unintended or unauthorized use, even if such claim alleges that Freescale Semiconductor was negligent regarding the design or manufacture of the part.

Freescale™ and the Freescale logo are trademarks of Freescale Semiconductor, Inc. All other product or service names are the property of their respective owners.
© Freescale Semiconductor, Inc. 2008. All rights reserved.

Looking for pricing, stock, or lifecycle information?

Click below to explore more details on WIN SOURCE:

 [View MRFG35020AR1 on WIN SOURCE](#)

 [NXP / Nexperia Information](#)

Optimize Your Supply Chain with WIN SOURCE Solutions

-  Global Sourcing Solution
-  Obsolete Management
-  Cost Control Management
-  Shortage Management
-  Alternative Solution
-  Excess Inventory Management