



**THE DATASHEET OF  
EVAL-AD7124-4SDZ**



## Evaluation Board for the [AD7124-4](#) 4-Channel, Low Noise, Low Power, 24-Bit, Sigma-Delta ADC with In-Amp and Reference

### FEATURES

Full featured evaluation board for the [AD7124-4](#)  
PC control in conjunction with the Analog Devices, Inc.,  
System Demonstration Platform ([EVAL-SDP-CB1Z](#))  
PC software for control and data analysis (time domain)  
Standalone capability

### EVALUATION KIT CONTENTS

[EVAL-AD7124-4SDZ](#) evaluation board  
Evaluation software CD for the [AD7124-4](#)

### ONLINE RESOURCES

#### Documents Needed

[AD7124-4](#) data sheet  
[EVAL-AD7124-4SDZ](#) user guide

#### Required Software

[AD7124-4 EVAL+ Software](#)

### EQUIPMENT NEEDED

[EVAL-AD7124-4SDZ](#) evaluation board  
[EVAL-SDP-CB1Z](#) System Demonstration Platform  
DC signal source  
USB cable  
PC running Windows with USB 2.0 port

### GENERAL DESCRIPTION

The [EVAL-AD7124-4SDZ](#) evaluation kit features the [AD7124-4](#) 24-bit, low power, low noise analog-to-digital converter (ADC).

A 7 V to 9 V external supply is regulated to 3.3 V to supply the [AD7124-4](#) and to support all necessary components. The [EVAL-AD7124-4SDZ](#) board connects to the USB port of the PC via the connection to the [EVAL-SDP-CB1Z](#) motherboard.

The [AD7124-4 EVAL+ Software](#) fully configures the [AD7124-4](#) device register functionality and provides dc time domain analysis in the form of waveform graphs, histograms, and associated noise analysis for ADC performance evaluation.

The [EVAL-AD7124-4SDZ](#) is an evaluation board that allows the user to evaluate the features of the ADC. The user PC software executable controls the [AD7124-4](#) over the USB through the [EVAL-SDP-CB1Z](#) System Demonstration Platform (SDP) board.

Full specifications on the [AD7124-4](#) are available in the product data sheet, which should be consulted in conjunction with this user guide when working with the evaluation board.

**TABLE OF CONTENTS**

Features .....	1	Analog Inputs.....	7
Evaluation Kit Contents.....	1	Reference Options .....	8
Online Resources .....	1	Evaluation Board Setup Procedures .....	8
Equipment Needed.....	1	Evaluation Board Software.....	9
General Description .....	1	Software Installation Procedures.....	9
Revision History .....	2	Software Operation .....	12
EVAL-AD7124-4SDZ Block Diagram .....	3	Configuration Tab .....	12
EVAL-AD7124-4SDZ Quick Start Guide.....	4	Waveform Tab.....	14
Evaluation Board Hardware .....	5	Histogram Tab .....	16
Device Description.....	5	Register Map Tab.....	17
Hardware Link Options.....	5	Noise Test—Quick Start Demonstration .....	18
Power Supplies .....	7	Evaluation Board Schematics and Artwork.....	20
Serial Interface .....	7	Bill of Materials.....	27

**REVISION HISTORY**

7/15—Revision 0: Initial Version

**EVAL-AD7124-4SDZ BLOCK DIAGRAM**

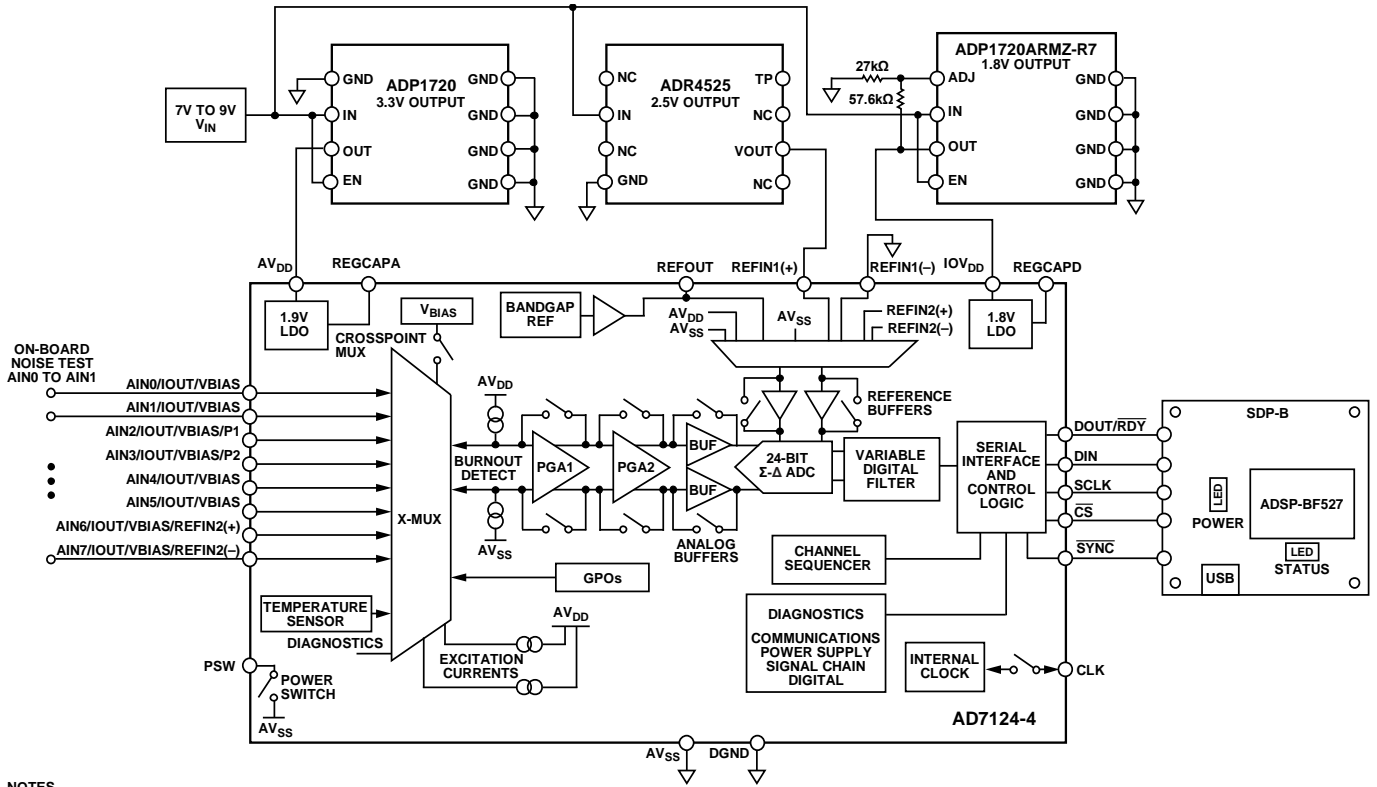

NOTES  
 1. FOR SIMPLICITY, DECOUPLING NOT SHOWN.

Figure 1.

13304-001

## EVAL-AD7124-4SDZ QUICK START GUIDE

To begin using the evaluation board, do the following:

1. With the [EVAL-SDP-CB1Z](#) board disconnected from the USB port of the PC, install the [AD7124-4 EVAL+ Software](#) (the software is included on the CD in the evaluation kit, or it can be downloaded from the Analog Devices website). The PC must be restarted after the software installation is complete. (For complete software installation instructions, see the Software Installation Procedures section.)
2. Connect the [EVAL-SDP-CB1Z](#) board to the [EVAL-AD7124-4SDZ](#) board.
3. Screw the two boards together using the plastic screw and washer set included in the evaluation board kit to ensure that the boards are connected firmly together.
4. Apply an external voltage in the range of 7 V to 9 V to the J3 or J5 connector of the [EVAL-AD7124-4SDZ](#) board. This provides the power supply for the board.
5. Connect the [EVAL-SDP-CB1Z](#) board to the PC using the supplied USB cable. If you are using Windows® XP, you may need to search for the [EVAL-SDP-CB1Z](#) drivers. Choose to automatically search for the drivers for the [EVAL-SDP-CB1Z](#) board if prompted by the operating system.
6. From the **Programs** menu, go to the **Analog Devices** subfolder, and click **AD7124 Eval+** to launch the [AD7124-4 EVAL+ Software](#) (see the Launching the Software section for further details).



Figure 2. Hardware Configuration, Setting Up the [EVAL-AD7124-4SDZ](#) Evaluation Board

13304-002

## EVALUATION BOARD HARDWARE

### DEVICE DESCRIPTION

The [AD7124-4](#) is a low power, low noise, complete analog front end for high precision measurement applications. It contains a low noise, 24-bit,  $\Sigma$ - $\Delta$  ADC. It can be configured to have four differential inputs or seven single-ended or pseudo differential inputs. The on-chip low noise instrumentation amplifier means that signals of small amplitude can be interfaced directly to the ADC. Other on-chip features include a low drift 2.5 V reference, excitation currents, reference buffers, multiple filter options, and many diagnostic features.

Complete specifications for the [AD7124-4](#) are provided in the product data sheet, which should be consulted in conjunction with this user guide when using the evaluation board. Full details about the [EVAL-SDP-CB1Z](#) are available on the Analog Devices website.

### HARDWARE LINK OPTIONS

Table 1 lists the default link options. By default, the board is configured to operate from a wall wart (dc plug) power supply via Connector J5. The supply required for the [AD7124-4](#) comes from the on-board [ADP1720](#) low dropout regulators (LDOs), which generate their voltage from J5.

**Table 1. Default Link and Solder Link Options**

Link No.	Default Option	Description
LK1	A	Connects the $AV_{DD}$ voltage to the power supply sequencer, <a href="#">ADM1185</a> . When $AV_{DD}$ equals 3.3 V, LK1 must be in Position A. When $AV_{DD}$ equals 1.8 V, LK1 must be in Position B.
LK2	B	Selects the connector for the external 7 V to 9 V power supply. In Position A, this link selects the external 7 V to 9 V power supply to come from Connector J3. In Position B, this link selects the external 7 V to 9 V power supply to come from Connector J5.
LK3	Inserted	Inserting this link connects $REFIN(-)$ to $AV_{SS}$ .
LK4	2.5 V	Selects the reference source for the ADC. In Position 2.5 V, $REFIN1(+)$ is connected to the external 2.5 V reference ( <a href="#">ADR4525</a> ). In Position INT REF, $REFIN1(+)$ is connected to the $REFOUT$ pin of the <a href="#">AD7124-4</a> . The internal reference of the <a href="#">AD7124-4</a> can be enabled and applied to the <a href="#">AD7124-4</a> external to the ADC.
LK5	Inserted	This link shorts $AIN0$ to $AIN1$ . This is useful for performing noise tests on the <a href="#">AD7124-4</a> . The internal bias can be enabled on $AIN0$ or $AIN1$ so that $AIN0$ and $AIN1$ are at an appropriate voltage for the noise test.
LK6	Inserted	LK6 can be used to connect the $AIN4$ and $AIN5$ channels to external components such as an external amplifier. The jumpers in Position A and Position B at LK6 must be opened to include the external component on the front end. Jumper A and Jumper B of this link can be used to connect the $AIN4$ and $AIN5$ channels to external components such as an external amplifier. For this, the jumpers must be open. Having Jumper A and Jumper B in place connects $AIN4$ and $AIN5$ to on-board thermistor used for cold junction measurements.
SL2	A	Sets the voltage applied to the $AV_{DD}$ pin. In Position A, this link sets the voltage applied to the $AV_{DD}$ pin to be a 3.3 V supply from the <a href="#">ADP1720-3.3</a> (U7) regulator or a 2.5 V supply from the <a href="#">ADP1720</a> (U4) regulator. In Position B, this link sets the voltage applied to the $AV_{DD}$ pin to be supplied from an external voltage source via Connector J9.
SL3, SL7	A, A	With SL3 and SL7 in Position A, $AV_{DD}$ is supplied with 3.3 V from the <a href="#">ADP1720-3.3</a> (U7) regulator. With SL3 and SL7 in Position B, $AV_{DD}$ is supplied with 1.8 V from the <a href="#">ADP1720</a> (U4) regulator.
SL5	B	With this link in Position A, the $IOV_{DD}$ supply is provided from an external source via Connector J9. With this link in Position B, the 3.3 V supply is generated by the <a href="#">ADP1720-3.3</a> (U10) regulator. The evaluation system operates with 3.3 V logic.
$AV_{SS}$ to AGND		When these links are inserted, $AV_{SS}$ is tied to AGND. When $AV_{SS}$ is set to $-1.8$ V, these links must be removed.

**On-Board Connectors**

Table 2 provides information about the external connectors on the [EVAL-AD7124-4SDZ](#).

**Table 2. On-Board Connectors**

Connector	Function
J1	A 120-pin connector that mates with the <a href="#">EVAL-SDP-CB1Z</a> (controller board).
J2	Straight PCB mount SMB/SMA jack for master clock (not inserted). The <a href="#">EVAL-AD7124-4SDZ</a> has the footprint to include an SMA/SMB connector, if an external clock source is being used to provide the master clock to the ADC.
J3	Bench top power supply voltage input. Apply 7 V to 9 V and GND (0 V) to this connector to power the evaluation board.
J5	Wall wart (dc plug) power supply voltage input. Apply 7 V to 9 V and GND (0 V) to this connector to power the evaluation board.
J6	Analog input connector. Connections to AIN0 to AIN5 are available along with REFIN1(±) connections. This connector can be used to connect an RTD to the <a href="#">AD7124-4</a> .
J9	Optional external connector, allowing external bench top or alternative supply for AV <sub>DD</sub> and IOV <sub>DD</sub> . When split supplies are used, AV <sub>SS</sub> is supplied externally via J9.
J11	Analog input connector. Connections to AIN6 to AIN7 are available along with REFIN1(±) and analog power supply connections. This connector can be used to connect a load cell to the <a href="#">AD7124-4</a> .
J12	6-pin connector. Provides an I <sup>2</sup> C interface to allow the SDP to interface to a digital temperature sensor. This is required if a thermocouple is interfaced to the <a href="#">AD7124-4</a> using Connector A2.
J13	7-pin connector that can be used to connect an external amplifier to Channel AIN4/Channel AIN5.
J14	7-pin connector that allows connection to the AIN4 and AIN5 pins.
A0	Straight PCB mount SMB/SMA jack. The footprint for an SMA/SMB connector is included on the evaluation board to provide the signal to the AIN4 analog input.
A1	Straight PCB mount SMB/SMA jack. The footprint for an SMA/SMB connector is included on the evaluation board to provide the signal to the AIN5 analog input.
A2	Thermocouple connector. This connector is required if a thermocouple is being interfaced to the evaluation board.
A5	Straight PCB mount SMB/SMA jack. The footprint for an SMA/SMB connector is included on the evaluation board to provide the REFIN1(+) signal.
A6	Straight PCB mount SMB/SMA jack. The footprint for an SMA/SMB connector is included on the evaluation board to provide the REFIN1(-) signal.

## POWER SUPPLIES

The evaluation board requires that an external power supply—either a bench top supply or a wall wart (dc plug) supply—be applied to J3 or J5 (see Table 3 for more information). Linear regulators generate the required power supply levels from the applied  $V_{IN}$  rail. The regulators used are the [ADP1720-3.3](#) (U7) and the [ADP1720](#) (U4), which supply 3.3 V and 1.8 V, respectively, to  $AV_{DD}$  of the ADC. The 3.3 V [ADP1720](#) (U10) delivers 3.3 V to the  $IOV_{DD}$  pin of the [AD7124-4](#).

When a split power supply is used, the  $AV_{SS}$  voltage must be applied from an external source via Connector J9.  $AV_{DD}$  and  $IOV_{DD}$  can also be provided via Connector J9. However, the 7 V to 9 V supply is still required because the on-board reference ([ADR4525](#)) is supplied from this power supply.

Each supply is decoupled at the point where it enters the board and again at the point where it connects to each device (see the schematics shown in Figure 26 to Figure 29 to identify decoupling points).

## SERIAL INTERFACE

The [EVAL-AD7124-4SDZ](#) evaluation board connects via the serial peripheral interface (SPI) to the Blackfin® [ADSP-BF527](#) on the [EVAL-SDP-CB1Z](#). There are four primary signals: CS, SCLK, DIN, and  $DOUT/\overline{RDY}$  (all are inputs, except for  $DOUT/\overline{RDY}$ , which is an output).

To operate the [EVAL-AD7124-4SDZ](#) in standalone mode, the [AD7124-4](#) serial interface lines can be disconnected from the 120-pin header by removing the 0  $\Omega$  links, R9 through R13. The test points can then be used to fly-wire the signals to an alternative digital capture setup.

## ANALOG INPUTS

The [EVAL-AD7124-4SDZ](#) primary analog inputs can be applied in two ways:

- Using J6 and J11, the green screw in terminal connectors
- Using the A0 and A1 SMB/SMA footprints on the evaluation board, which connect to the AIN4 and AIN5 analog inputs.

The [AD7124-4 EVAL+ Software](#) is set up to analyze dc inputs to the ADC.

**Table 3. Required External Power Supply<sup>1</sup>**

Power Supply ( $V_{IN}$ ) Applied To	Voltage Range	Function
J3	7 V to 9 V	Bench top supply to the evaluation board. Supplies LDOs that create the 3.3 V and 1.8 V rails. It also supplies the <a href="#">ADR4525</a> external reference. Ensure that LK2 is set to Position A when the external power supply is applied to this connector.
J5	7 V to 9 V	Wall wart (dc plug) supply to the evaluation board. Supplies LDOs that create the 3.3 V and 1.8 V rails. It also supplies the <a href="#">ADR4525</a> external reference. Ensure that LK2 is set to Position B when the external power supply is applied to this connector.

<sup>1</sup> Only a single supply is required, either J3 or J5. This supply can be selected using LK2.

**REFERENCE OPTIONS**

The EVAL-AD7124-4SDZ includes an external 2.5 V reference (the ADR4525) and an internal 2.5 V reference. The default operation is to use the external reference input, which is set to accept the 2.5 V ADR4525 on the evaluation board.

The reference used for a conversion is selected by choosing the reference in the configuration registers associated with Setup 0 to Setup 7. Switch between using the internal reference and external reference by accessing the AD7124-4 registers through the pop-up windows (discussed in more detail in the following sections) via the evaluation software. Figure 3 shows how to select the reference source for Setup 0 to Setup 7. Figure 4 shows the ADC\_CONTROL register setting that enables the internal reference.

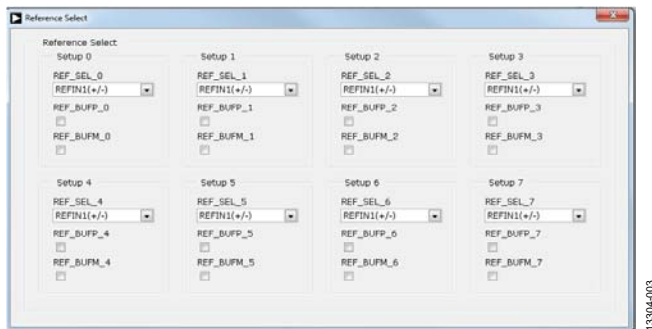

Figure 3. Selecting the Reference Source

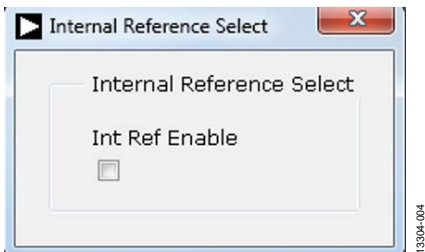

Figure 4. Enabling the Internal 2.5 V Reference

**EVALUATION BOARD SETUP PROCEDURES**

After following the instructions in the Software Installation Procedures section, set up the evaluation and SDP boards as detailed in this section.

**Warning**

The evaluation software and drivers must be installed before connecting the evaluation board and EVAL-SDP-CB1Z board to the USB port of the PC to ensure that the evaluation system is correctly recognized when it is connected to the PC.

**Configuring the Evaluation and SDP Boards**

1. Connect the EVAL-SDP-CB1Z board to Connector A or Connector B on the EVAL-AD7124-4SDZ board. Screw the two boards together using the plastic screw and washer set included in the evaluation board kit to ensure that the boards are connected firmly together.
2. Connect the power supplies to the EVAL-AD7124-4SDZ board. The EVAL-AD7124-4SDZ board, by default, uses the wall wart (dc plug) supply that accompanies the evaluation kit. Connect this supply to J5 on the EVAL-AD7124-4SDZ board. (For more information about the required connections and available options, see the Power Supplies section.)
3. Connect the EVAL-SDP-CB1Z board to the PC using the supplied USB cable.

## EVALUATION BOARD SOFTWARE SOFTWARE INSTALLATION PROCEDURES

The EVAL-AD7124-4SDZ evaluation kit includes a CD containing software to be installed on the PC before using the evaluation board.

There are two procedures in the installation:

- AD7124-4 EVAL+ Software installation
- EVAL-SDP-CB1Z SDP board drivers installation

### Warning

The evaluation software and drivers must be installed before connecting the evaluation board and EVAL-SDP-CB1Z board to the USB port of the PC to ensure that the evaluation system is correctly recognized when it is connected to the PC.

### Installing the AD7124-4 EVAL+ Software

To install the AD7124-4 EVAL+ Software, do the following:

1. With the EVAL-SDP-CB1Z board disconnected from the USB port of the PC, insert the installation CD into the CD-ROM drive.
2. Double-click the **setup.exe** file to begin the evaluation board software installation. The software installs to the following default location: **C:\Program Files\Analog Devices\AD7124 EVAL+**.
3. A dialog box appears asking for permission to allow the program to make changes to your PC. Click **Yes**.

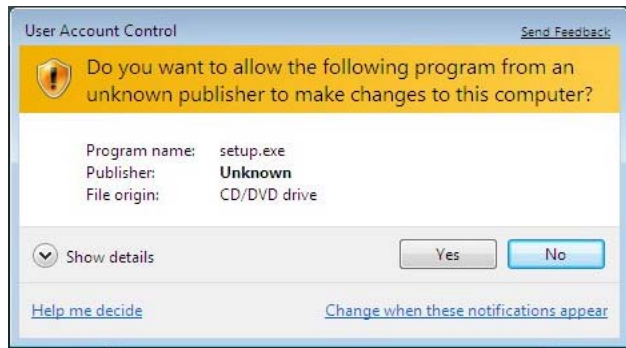

Figure 5. AD7124-4 EVAL+ Software Installation: Granting Permission for the Program to Make Changes to Your PC

4. Select the location to install the software, and then click **Next**. (Figure 6 shows the default locations, which are displayed when the window opens; you can select another location by clicking **Browse**.)



Figure 6. AD7124-4 EVAL+ Software Installation: Selecting the Location for Software Installation

5. A license agreement appears. Read the agreement, select **I accept the License Agreement**, and click **Next**.

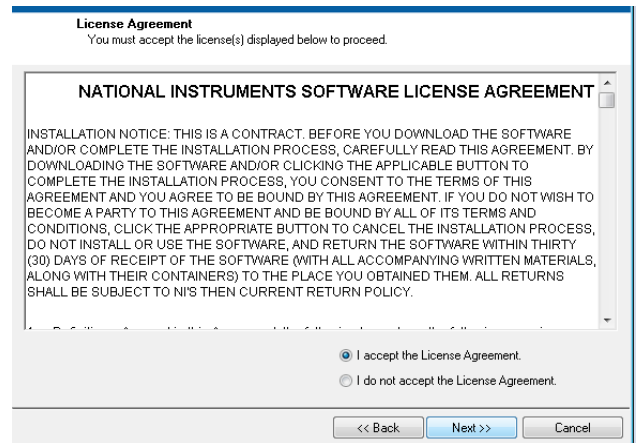

Figure 7. AD7124-4 EVAL+ Software Installation: Accepting the License Agreement

6. A summary of the installation displays. Click **Next** to continue.

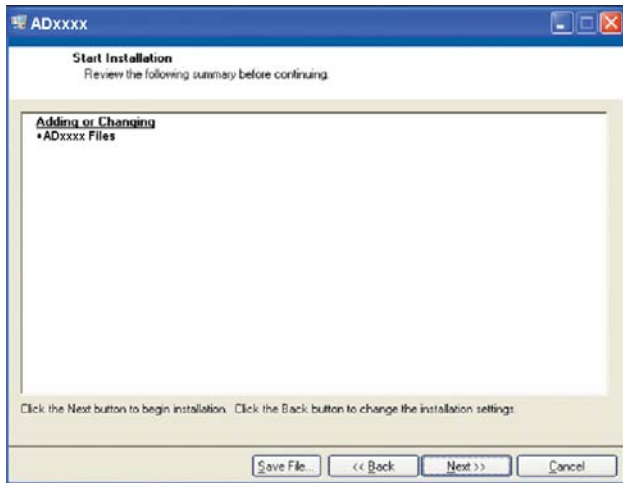

Figure 8. AD7124-4 EVAL+ Software Installation: Reviewing a Summary of the Installation

7. The message in Figure 9 appears when the installation is complete. Click **Next**.

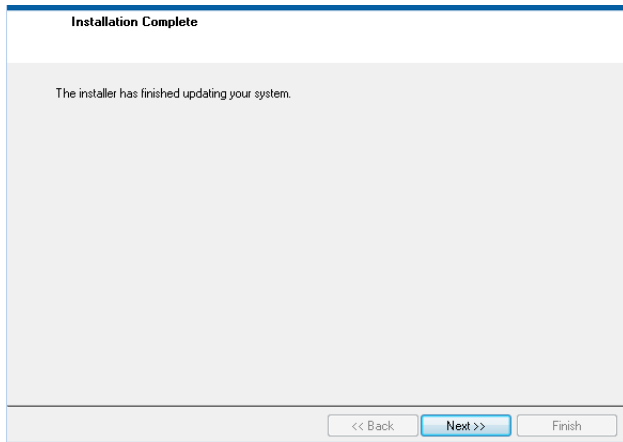

Figure 9. AD7124-4 EVAL+ Software Installation: Indicating When the Installation Is Complete

**Installing the EVAL-SDP-CB1Z System Demonstration Platform Board Drivers**

After the installation of the evaluation software is complete, a welcome window displays for the installation of the SDP board drivers.

1. With the EVAL-SDP-CB1Z board still disconnected from the USB port of the PC, make sure that all other applications are closed, and then click **Next**.

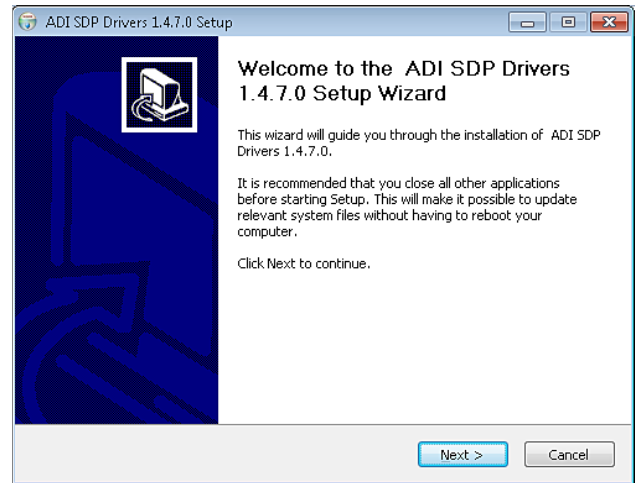

Figure 10. EVAL-SDP-CB1Z Drivers Setup: Beginning the Drivers Installation

2. Select the location to install the drivers, and then click **Next**.

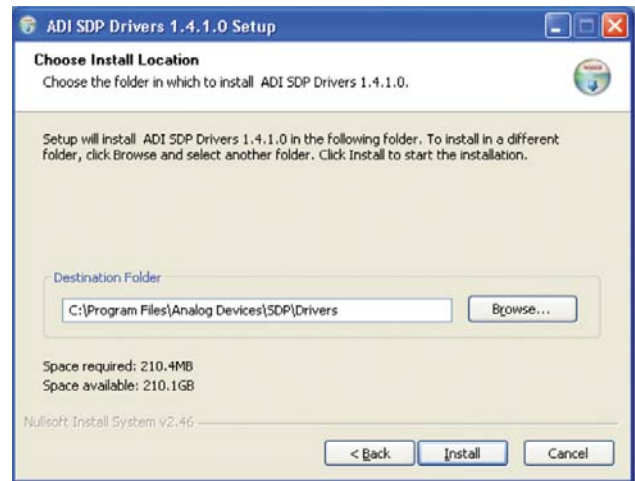

Figure 11. EVAL-SDP-CB1Z Drivers Setup: Selecting the Location for Drivers Installation

3. Click **Install** to confirm that you want to install the drivers.

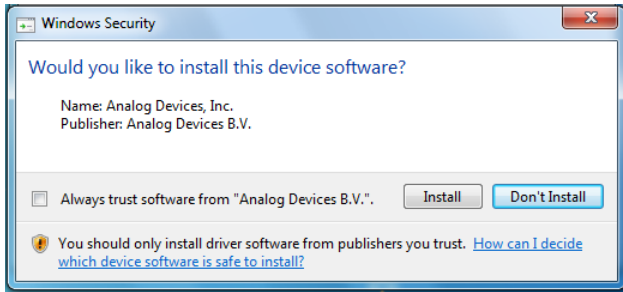

Figure 12. EVAL-SDP-CB1Z Drivers Setup: Granting Permission to Install Drivers

4. To complete the drivers installation, click **Finish**, which closes the setup wizard.

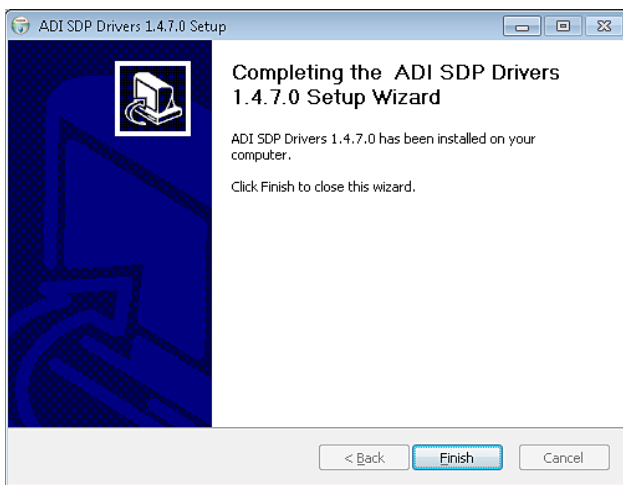

Figure 13. EVAL-SDP-CB1Z Drivers Setup: Completing the Drivers Setup Wizard

5. Before using the evaluation board, you must restart the PC.

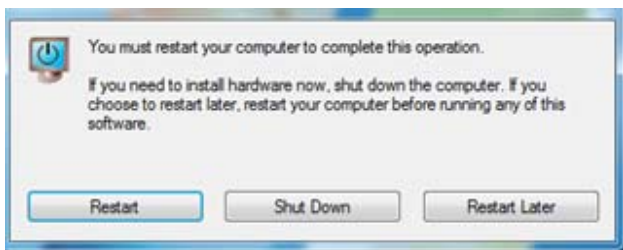

Figure 14. EVAL-SDP-CB1Z Drivers Setup: Restarting the PC

**Setting Up the System for Data Capture**

After completing the steps in the Software Installation Procedures and Evaluation Board Hardware sections, set up the system for data capture as follows:

1. Allow the **Found New Hardware Wizard** to run after the **EVAL-SDP-CB1Z** board is plugged into your PC. (If you are using Windows XP, you may need to search for the **EVAL-SDP-CB1Z** drivers. Choose to automatically search for the drivers for the **EVAL-SDP-CB1Z** board if prompted by the operating system.)
2. Check that the board is connecting to the PC correctly using the **Device Manager** of the PC.
3. Access the **Device Manager** as follows:
  - a. Right-click **My Computer** and then click **Manage**.
  - b. A dialog box appears asking for permission to allow the program to make changes to your PC. Click **Yes**.
  - c. The **Computer Management** window appears. From the list of **System Tools**, click **Device Manager** (see Figure 15).
  - d. The **EVAL-SDP-CB1Z** board should appear under **ADI Development Tools**, which indicates that the driver software is installed and that the board is connecting to the PC correctly.

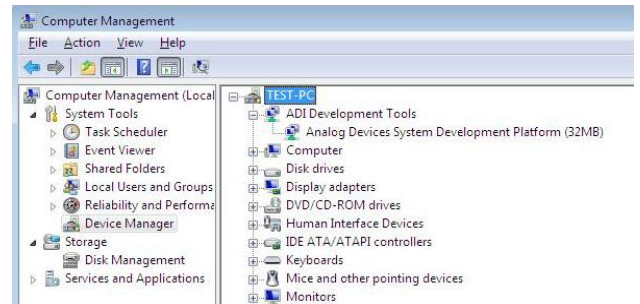

Figure 15. Device Manager: Checking that the Board Is Connected to the PC Correctly

**Launching the Software**

After completing the steps in the Setting Up the System for Data Capture section, launch the [AD7124-4 EVAL+ Software](#) as follows:

1. From the **Start** menu, click **Programs > Analog Devices > AD7124 Eval+ > AD7124 Eval+**. The dialog box in Figure 19 appears; select **EVAL-AD7124-4SDZ**, and the main window of the software then displays as shown in Figure 20.
2. If the [AD7124-4](#) evaluation system is not connected to the USB port via the [EVAL-SDP-CB1Z](#) when the software is launched, a connectivity error displays (see Figure 16). Connect the evaluation board to the USB port of the PC, wait a few seconds, click **Rescan**, and then follow the on-screen instructions.



Figure 16. Connectivity Error Alert

When the software starts running, it searches for hardware connected to the PC. A dialog box indicates when the generic SDP attached to the PC is detected, and then the main window appears (see Figure 20). Press the RESET button on the SDP board, as shown in Figure 17.



Figure 17. SDP Connectivity Board—RESET Button

Pressing the RESET button causes the software to rescan for a connected SDP board. If found, the message shown in Figure 18 displays.



Figure 18. Connectivity when SDP and Evaluation Boards are Found

**SOFTWARE OPERATION**

**Overview of the Main Window**

The evaluation software supports both the [AD7124-4](#) and the [AD7124-8](#) devices. On running the software, the user selects the evaluation board that is connected to the PC. For the [AD7124-4](#), select **EVAL-AD7124-4SDZ** from the drop-down list, as shown in Figure 19.

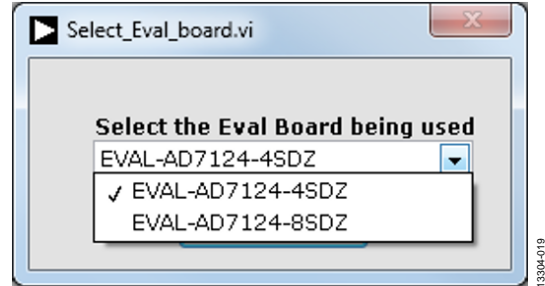

Figure 19. EVAL-AD7124-4SDZ Evaluation Board Selection

After selecting the [EVAL-AD7124-4SDZ](#) evaluation board, the main window of the evaluation software displays, as shown in Figure 20. Figure 20 shows the significant control buttons and analysis indicators of the [AD7124-4 EVAL+ Software](#). The main window of the [AD7124-4 EVAL+ Software](#) contains four tabs:

- Configuration
- Waveform
- Histogram
- Register Map

**CONFIGURATION TAB**

The **Configuration** tab shows a block diagram of the [AD7124-4](#). It allows the user to set up the ADC, reset the ADC, read the diagnostics to see errors present, as well as configure the device for different demo modes. Figure 20 shows the **Configuration** tab in more detail, and the following sections discuss the different elements on the **Configuration** tab of the software window.

**ADC Reset**

Click **ADC RESET** (Label 2) to perform a software reset of the [AD7124-4](#). There is no hardware reset pin on the [AD7124-4](#). A hard reset can be performed by removing power to the board. The software reset has the same effect as a hard reset.

**Selecting External Reference**

There are a number of different options that can be used when selecting the reference to the [AD7124-4](#). Two options are **AV<sub>DD</sub>** and **Refin1(+/-)** (Label 3). The **Refin1(+/-)** field sets the external reference voltage that is connected between **REFIN1(+)** and **REFIN1(-)**. Using the [EVAL-AD7124-4SDZ](#) evaluation board, the **AV<sub>DD</sub>** voltage is 3.3 V. Either of these can be used in calculating the results on the **Waveform** and **Histogram** tabs. The evaluation board has an external 2.5 V [ADR4525](#) reference, which can be bypassed; if bypassing the [ADR4525](#) on board, be sure to change the external reference voltage value in **Refin1(+/-)** to ensure correct calculation of results in the **Waveform** and **Histogram** tabs.

**Tutorial Button**

Clicking TUTORIAL (Label 4) opens a tutorial on using the software, which provides additional information on using the AD7124-4 EVAL+ Software.

**Functional Block Diagram**

The functional block diagram of the ADC (Label 5) shows each of the functional blocks within the ADC. Clicking a configuration button on this graph opens the configuration popup window for that block.

**Configuration Pop-Up Button**

Each configuration pop-up button (Label 6) opens a different window allowing configuration of the relevant functional block.

**CONFIG SUMMARY**

Clicking CONFIG SUMMARY (Label 7) displays the channel configuration, information on the individual setups, as well as information on any error present. These tabs can be used to quickly check how the ADC channels are configured, as well as any errors that are present.

**Demo Modes**

The AD7124-4 EVAL+ Software supports a number of demo modes (Label 8); these demo modes configure the AD7124-4 for each of the modes shown. A help file is available for each demo mode; to access this help file, click the question mark button.

**Status Bar**

The status bar (Label 9) displays status updates such as Analysis Completed, Reset Completed, and Configuring Demo Mode during software use, as well as the software version and the Busy indicator.

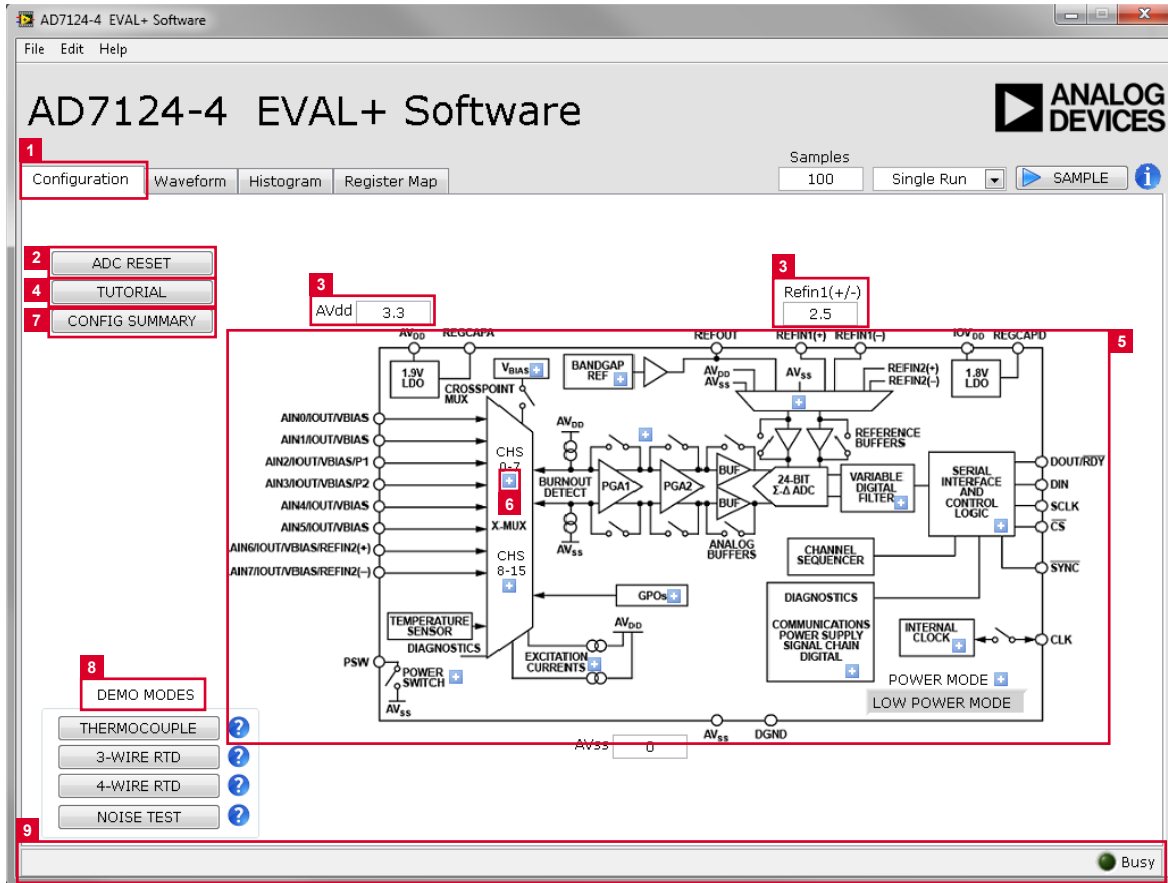

Figure 20. Configuration Tab of the AD7124-4 EVAL+ Software

## WAVEFORM TAB

The **Waveform** tab graphs the conversions and processes the data, calculating the p-p noise, rms noise, and resolution (see Figure 21).

### **Waveform Graph and Controls**

The data waveform graph (Label 1) shows each successive sample of the ADC output. Zoom in on the data using the control toolbar (Label 2) in the graph. Change the scales on the graph by typing values into the x-axis and y-axis.

### **Analysis Channel**

The **Noise Analysis** section and histogram graph show the analysis of the channel selected via the **Analysis Channel** control (Label 3).

### **Samples**

The **Samples** numeric control (Label 4) and batch control (Label 5) set the number of samples gathered per batch and whether a single batch or multiple batches of samples are gathered. This control is unrelated to the ADC mode. The user can capture a defined sample set or continuously gather batches of samples. In both cases, the number of samples set in the **Samples** numeric input dictates the number of samples.

### **Sample**

Click **SAMPLE** (Label 6) to start gathering ADC results. Results appear in the waveform graph (Label 1).

### **Channel Selection**

The channel selection control (Label 7) chooses which channels display on the data waveform, and also shows the analog inputs for the channel labeled next to the on and off controls. These controls only affect the display of the channels and have no effect on the channel settings in the ADC register map.

### **Display Units and Axis Controls**

Click the **Display Units** drop-down list (Label 8) to select whether the data graph displays in units of voltages or codes. This control affects both the waveform graph and the histogram graph. The axis controls can be switched between dynamic and fixed. When dynamic is selected, the axis automatically adjusts to show the entire range of the ADC results after each batch of sample. When fixed is selected, the user can program the axis ranges; the axis ranges do not automatically adjust after each batch of sample.

### **CRC Error and Overall Error**

The **CRC Error** LED indicator (Label 9) illuminates when a cyclic redundancy check (CRC) error is detected in the communications between the software and the [AD7124-4](#). The CRC functionality on the [AD7124-4](#) is disabled by default and must be enabled for this indicator to work. The **Error Present** LED indicates if an overall error is present in the diagnostics register. For this indicator to work, the check for the different diagnostic errors must be enabled in the Error\_EN register.

### **Noise Analysis**

The **Noise Analysis** section (Label 10) displays the results of the noise analysis for the selected analysis channel, which includes both noise and resolution measurements.

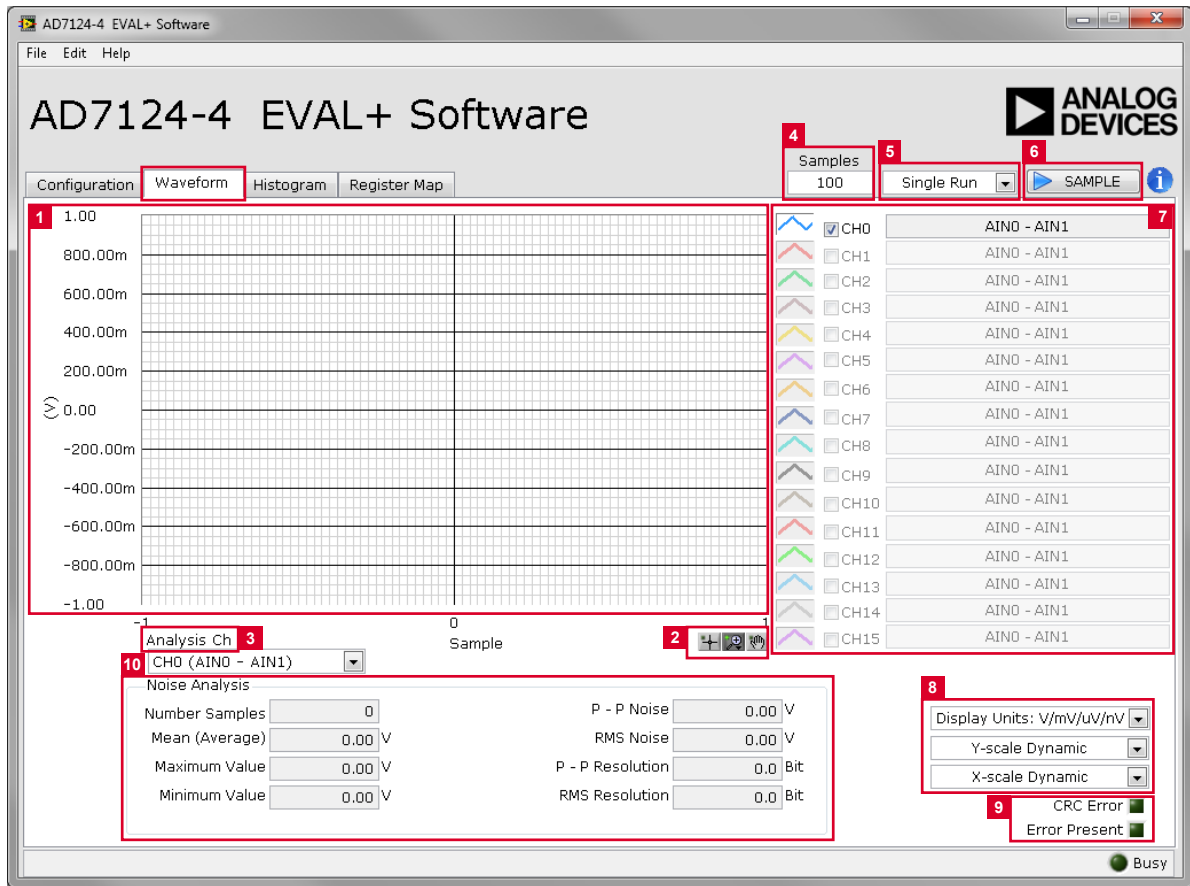

Figure 21. Waveform Tab of the AD7124-4 EVAL+ Software

**HISTOGRAM TAB**

The **Histogram** tab generates a histogram using the gathered samples and processes the data, calculating the peak-to-peak noise, rms noise, and resolution (see Figure 22).

**Histogram Graph and Controls**

The data histogram graph (Label 1) shows the number of times each sample of the ADC output occurs. Zoom in on the data using the control toolbar (Label 6) in the graph. Change the scales on the graph by typing values into the x-axis and y-axis.

**Analysis Channel**

The **Noise Analysis** section and histogram graph show the analysis of the channel selected via the **Analysis Channel** control (Label 2).

**Noise Analysis**

The **Noise Analysis** section (Label 3) displays the results of the noise analysis for the selected analysis channel, which includes both noise and resolution measurements.

**Display Units and Axis Controls**

Click the **Display Units** drop-down list (Label 4) to select whether the data graph displays in units of voltages or codes. This control affects both the waveform graph and the histogram graph. The axis controls can be switched between dynamic and fixed. When dynamic is selected, the axis automatically adjusts to show the entire range of the ADC results after each batch of sample. When fixed is selected, the user can program the axis ranges; the axis ranges do not automatically adjust after each batch of sample.

**CRC Error and Overall Error**

The **CRC Error** LED indicator (Label 5) illuminates when a cyclic redundancy check (CRC) error is detected, in the communications between the software and the AD7124-4. The CRC functionality on the AD7124-4 is disabled by default and must be enabled for this indicator to work. The **Error Present** LED (Label 5) indicates if an overall error is present in the diagnostics register. For this indicator to work, the check for the different diagnostic errors must be enabled in the Error\_EN register.

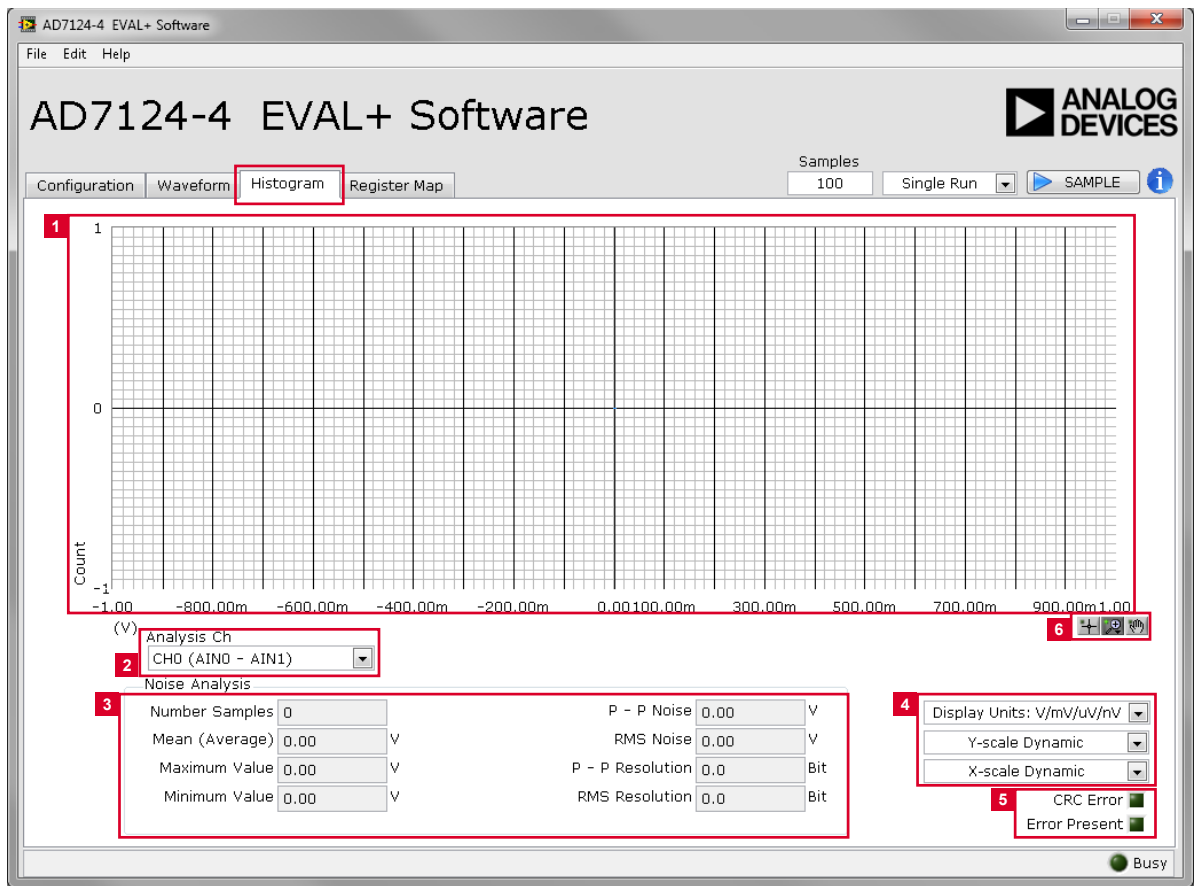

Figure 22. Histogram Tab of the AD7124-4 EVAL+ Software

**REGISTER MAP TAB**

Use the **Register Map** tab to access the registers of the [AD7124-4](#). Figure 23 shows the view when **Register Map** tab is selected. This tab can be used to quickly change register settings and also to obtain additional information about each of the bits in each of the individual registers.

**Register Map**

On the left-hand side of Figure 23 are the registers of the [AD7124-4](#). Click any register to read the register value. Each register of the [AD7124-4](#) can be accessed quickly using this register map (Label 1).

**Save and Load Buttons**

The **Save** and **Load** buttons (Label 2) in the **Register Map** tab allow the user to save and load register settings. Click **Save** to save all the current register settings to a file for use again later. Click **Load** to load a previously saved register map.

**Register**

The **Register** section (Label 3) shows the value that is currently set in the selected register. The value of the register can be

checked in this section by clicking the bits that are to be changed. Clicking any of the individual bit changes that bit from 1 to 0 or 0 to 1, depending on the initial state of the bit. The register value can also be changed by writing the hex value to the input field on the right-hand side of the individual bits.

**Bitfields**

The individual bitfields of the selected register are shown in the **Bitfields** section (Label 4). In this section, the register is broken by name into its bitfields, name of the bitfields, a description of each of each bitfield, as well as the access information. The options for the individual bitfields can be viewed by clicking the arrow next to the bitfield. Changing the bitfield value can also be done through this drop-down list. The value of the bitfield can also be changed by writing the appropriate hex value to the associated **Value** input field on the right-hand side of the bitfield.

**Documentation**

The **Documentation** section (Label 5) shows information relating to the different bit fields when selected from the register map section on the left. This information is the same information that is presented in the [AD7124-4](#) data sheet.

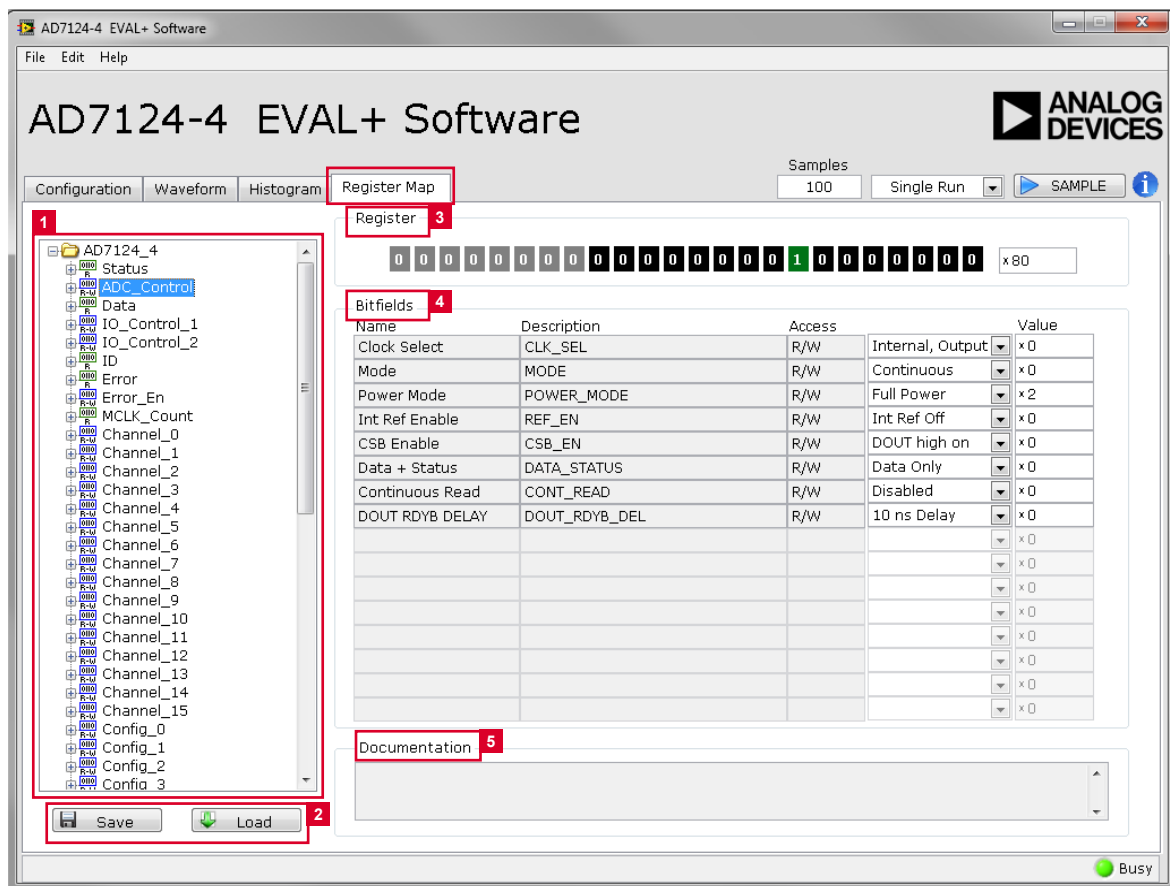

Figure 23. Register Map Tab of the AD7124-4 EVAL+ Software

**NOISE TEST—QUICK START DEMONSTRATION**

Click the **NOISE TEST** demo button to configure the device for the noise test. The **AD7124-4** is now configured for the noise test demo, where the output data rate is set to 9.38 SPS, with the sinc<sup>4</sup> digital filter, full power mode of operation, and the REF<sub>IN1</sub>(±) external reference selected. Gain and offset are the default factory values following a reset.

To gather samples, change the **Samples** field to the number of samples required value, then click **SAMPLE** to acquire the samples from the ADC. Figure 24 shows an example of the main window after running a noise test.

**Reading Samples from the ADC**

The evaluation board is set up to use the external 2.5 V on-board reference (**ADR4525**). To read samples from the ADC, take the following steps:

1. The value in the **Refin1(+/-)** field on the **Configuration** tab is set to 2.5 V by default to use the external 2.5 V on-board reference (**ADR4525**). If a different reference is used, set the value in the **Refin1(+/-)** field accordingly. The analysis results are based on the value set in this field.
  - a. When **Single Run** is selected from the drop-down list, a batch of samples is read when **SAMPLE** is clicked, with the batch size being set by the value in the **Samples** box.

- b. When the drop-down box is set to **Continuous Run**, the software performs a continuous capture from the ADC when **SAMPLE** is clicked.
  - c. Click **Stop** to stop streaming data.
2. Use the navigation tools within each graph to control the cursor, zooming, and panning.

**Waveform**

The waveforms resulting from the gathered samples are shown in this tab. The waveform graph shows each successive sample of the ADC output (input referred). The indicators beside this graph show the channels being converted. Navigation tools are provided to allow the user to control the cursor, zooming, and panning. The conversions can be displayed as codes or as volts.

Parameters such as peak-to-peak noise and rms noise are displayed below the graph in the **Analysis** section for the current batch of samples. If several analog input channels are enabled, each enabled channel can be selected and the conversions on that channel analyzed using **Analysis Channel**.

The conversion data can be saved in a text file from the **File** menu. To save the data into an Excel file, right-click the waveform graph and select **Export Data** from the drop-down list that appears. A **Save** dialog box displays, prompting the user to save the data to an appropriate folder location.

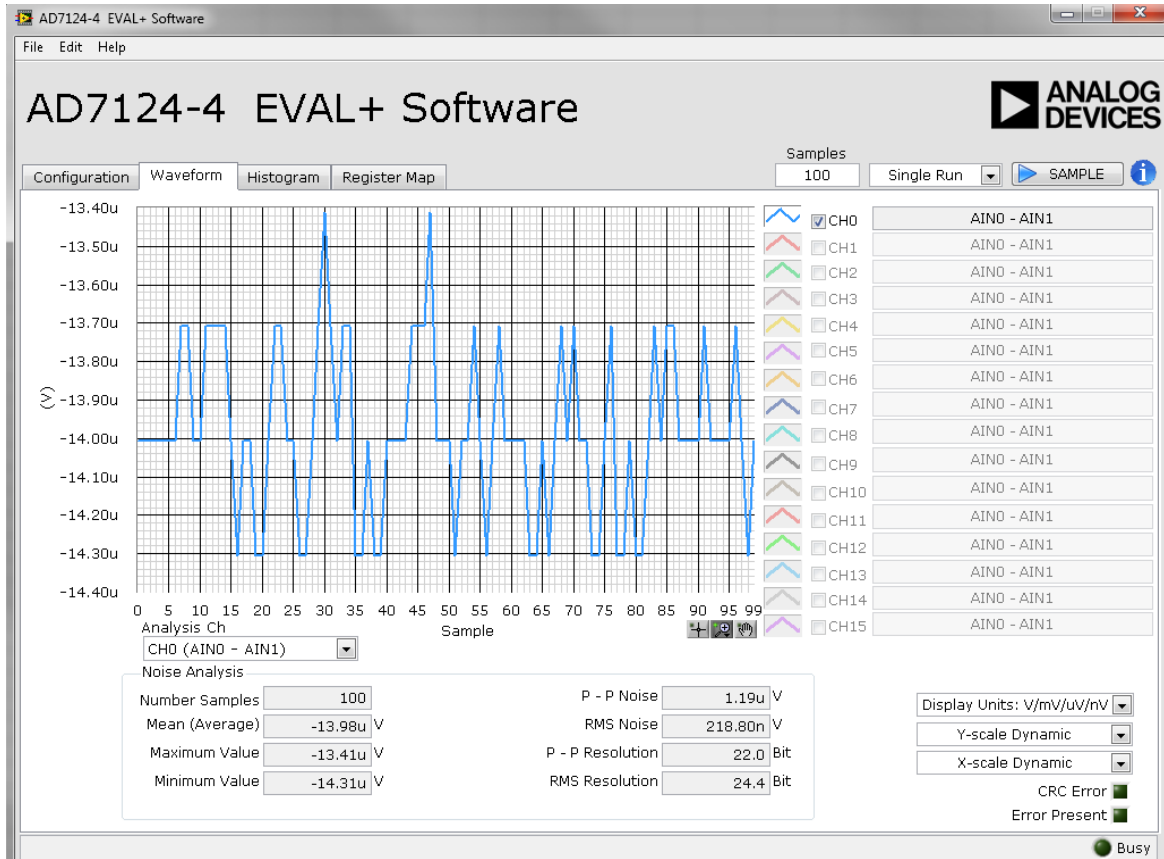

Figure 24. Example of the **Waveform** Tab After Running a Noise Test

**Histogram**

This tab shows the histogram analysis. The indicators beside this graph show the channels being converted. Navigation tools are provided to allow you to control the cursor, zooming, and panning. The conversions can be displayed as codes or as volts.

Parameters such as peak-to-peak noise and rms noise are displayed in the **Analysis Results** section for the current batch of samples.

The conversion data can be saved in a text file from the **File** at menu. To save the data into an Excel file, right-click the histogram graph and select **Export Data** from the drop-down list that appears. A **Save** dialog box displays, prompting the user to save the data to an appropriate folder location.

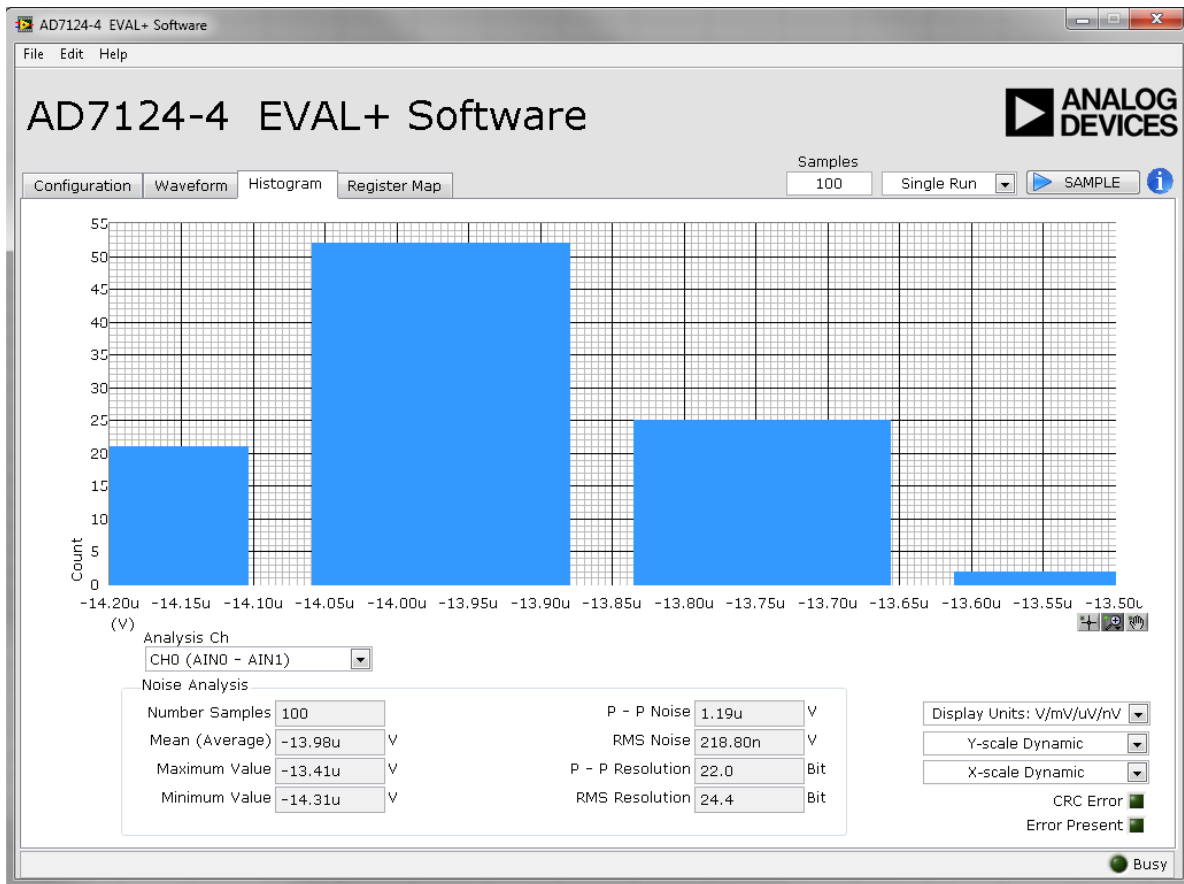

Figure 25. Example of the **Histogram** Tab After Running a Noise Test



13904-027

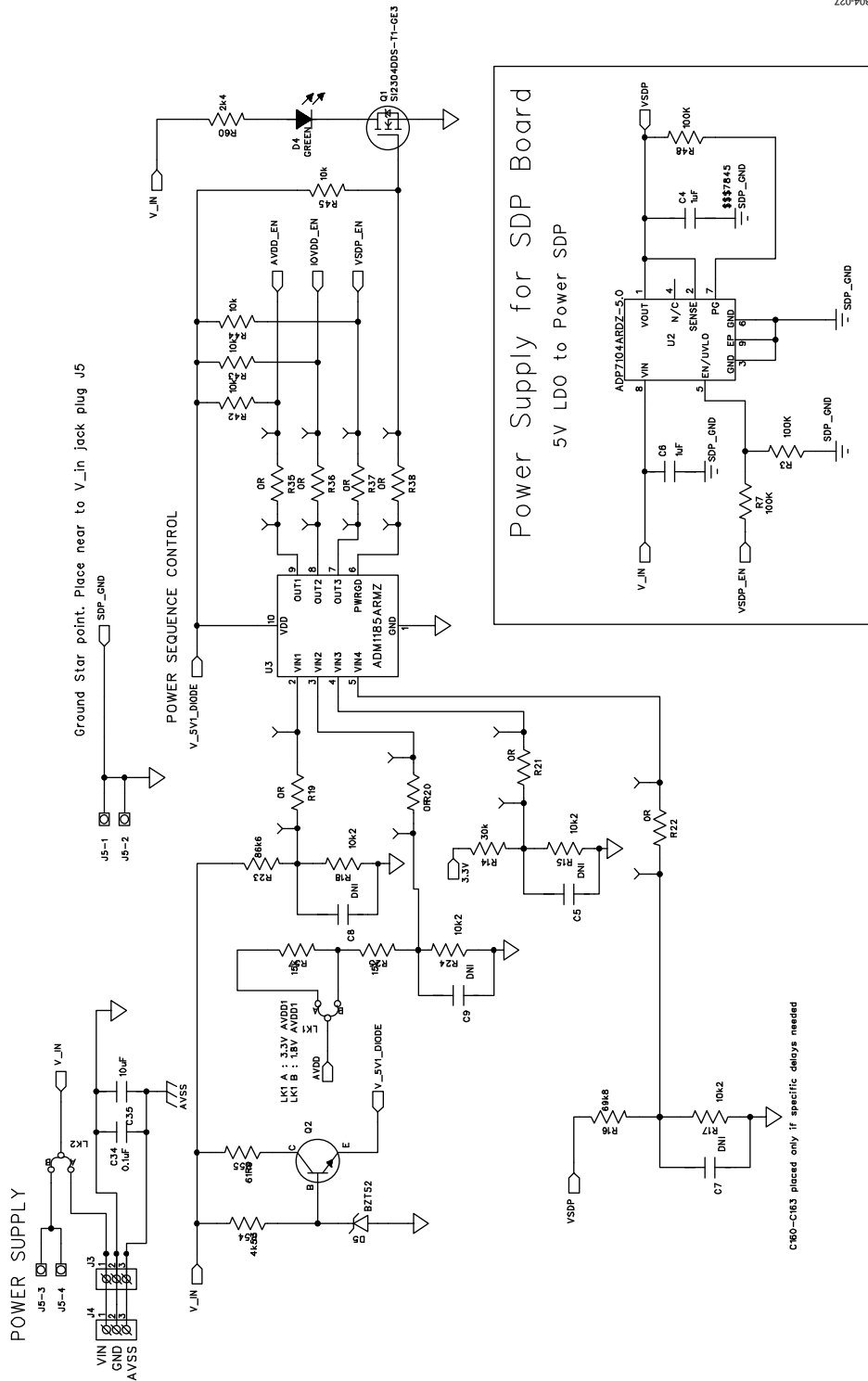

Figure 27. Schematic—Power Supply

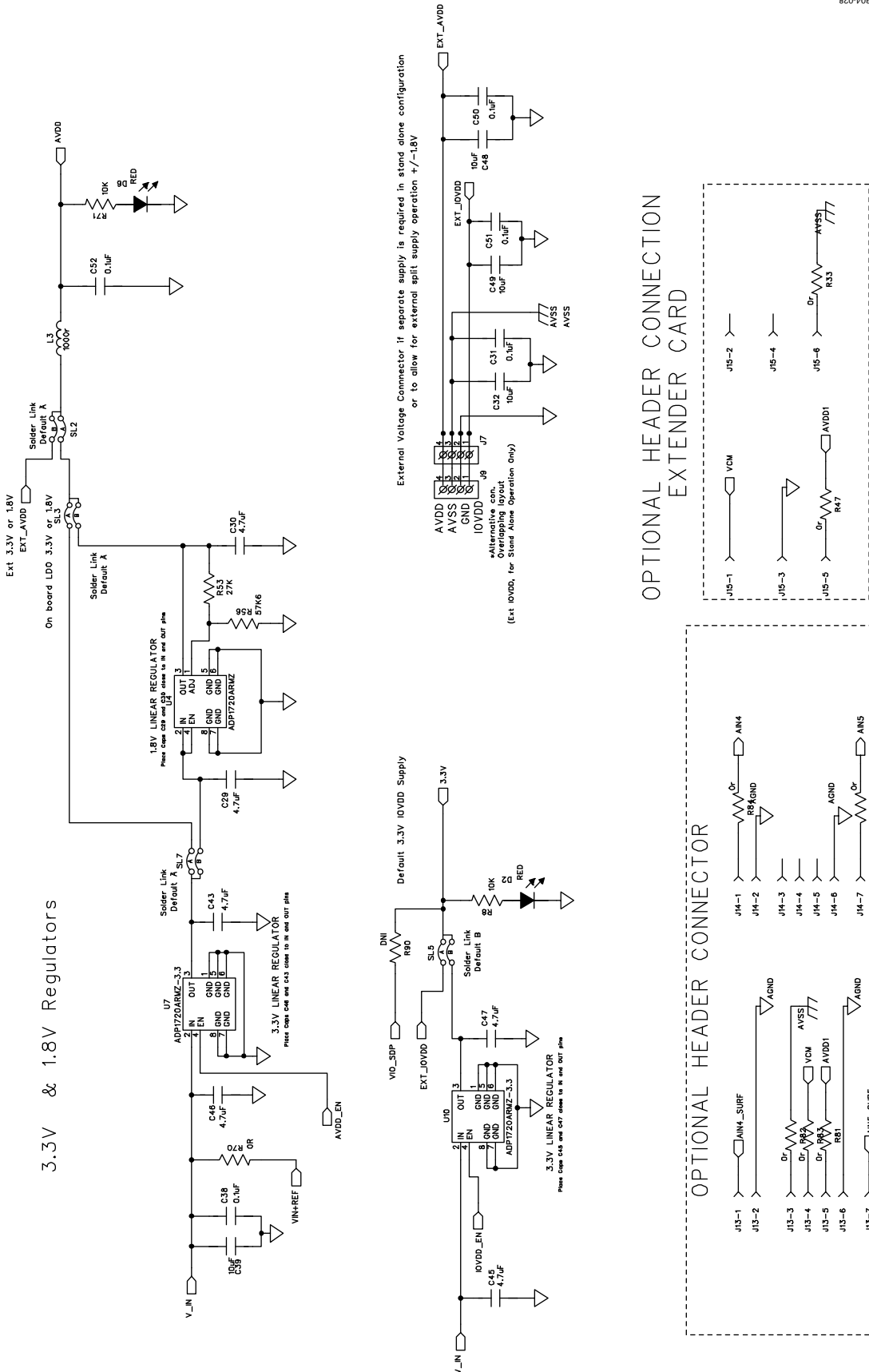

Figure 28. Schematic—Regulators

SDP CONNECTOR EEPROM-SW/USB ID

VIO: USE to set IO voltage max draw 20mA  
 VIN: Use this pin to power the SDP requires 4-7V 200mA  
 BMODE: Pull up with a 10K resistor to set SDP to boot from a SPI FLASH on the daughter board

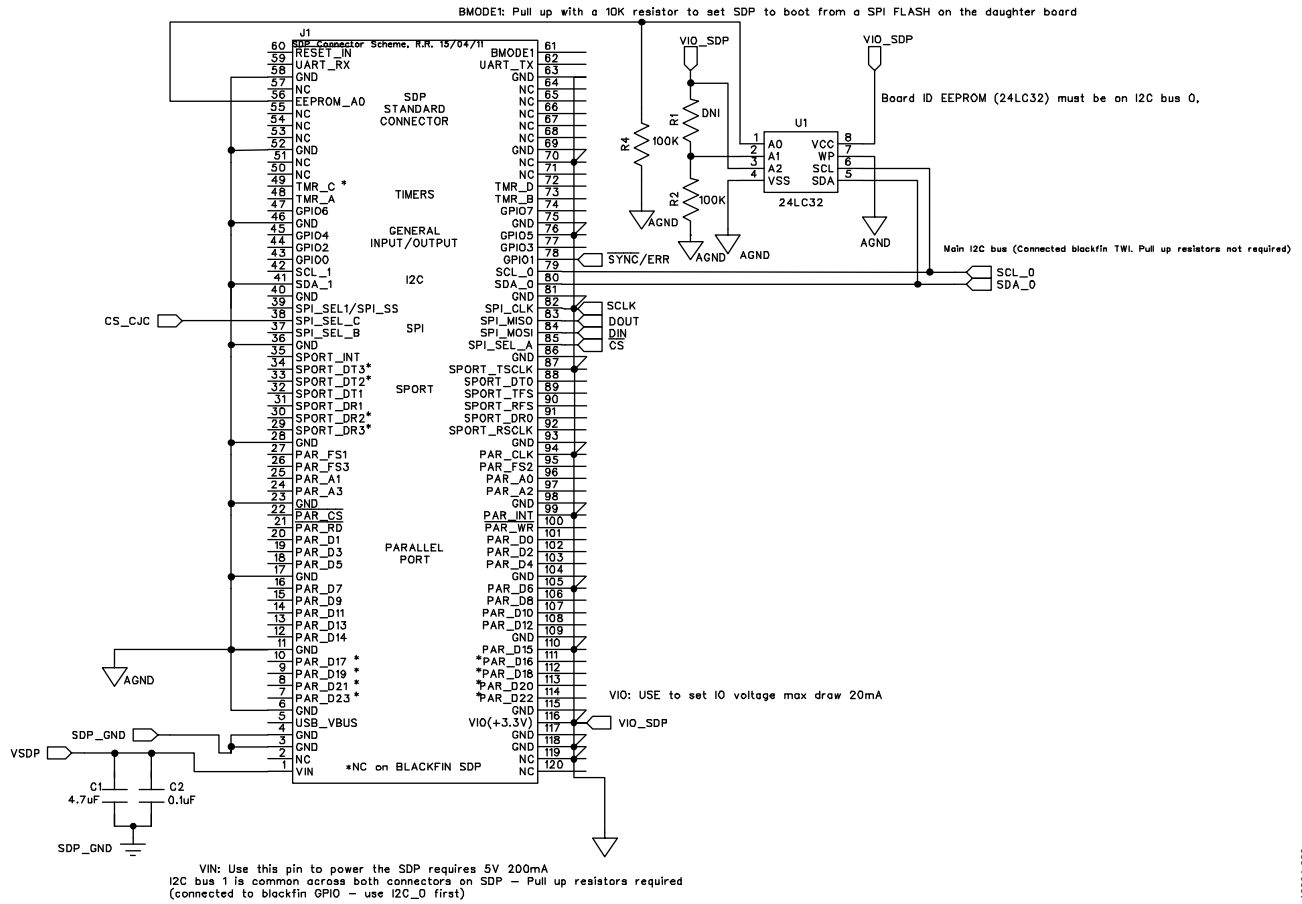

Figure 29. Schematic—SDP

13304-029

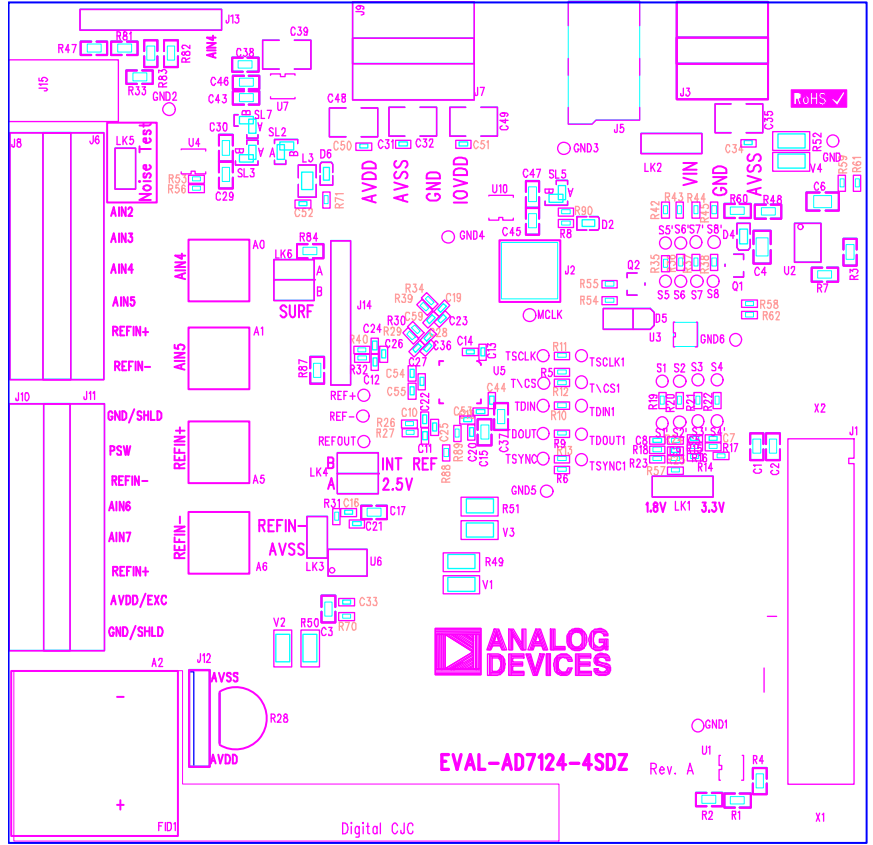

Figure 30. Top Printed Circuit Board (PCB) Silkscreen

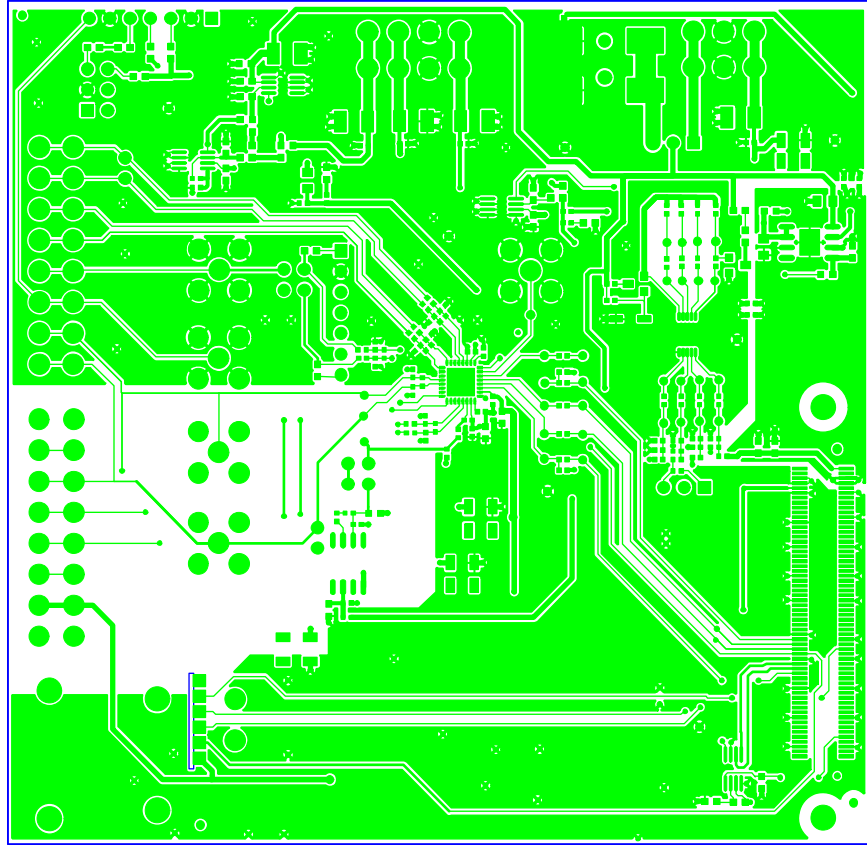

Figure 31. Layer 1—Component Side

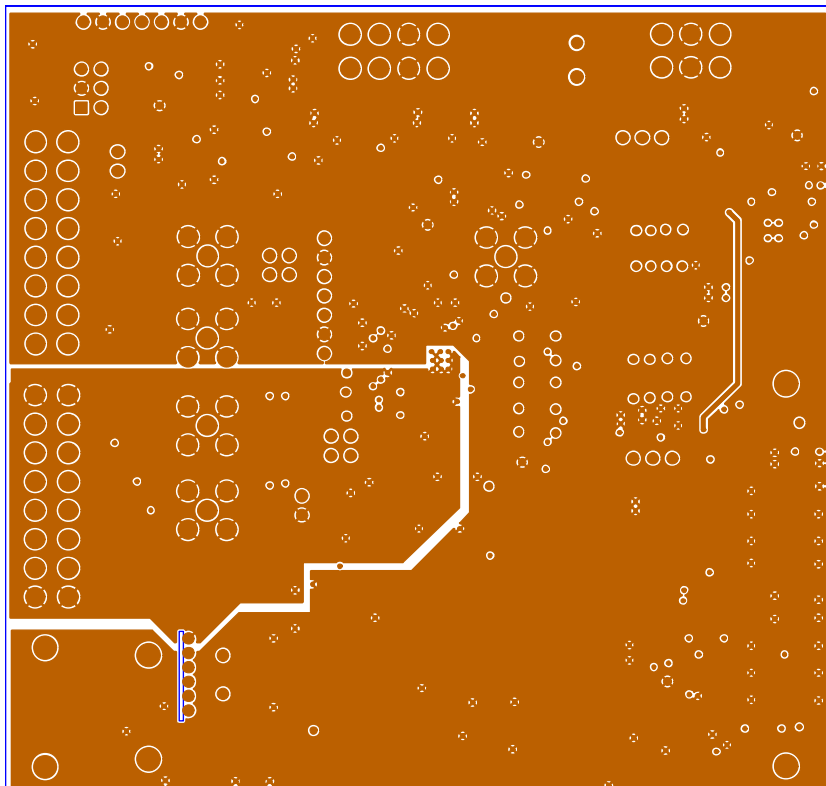

Figure 32. Layer 2—Ground Plane

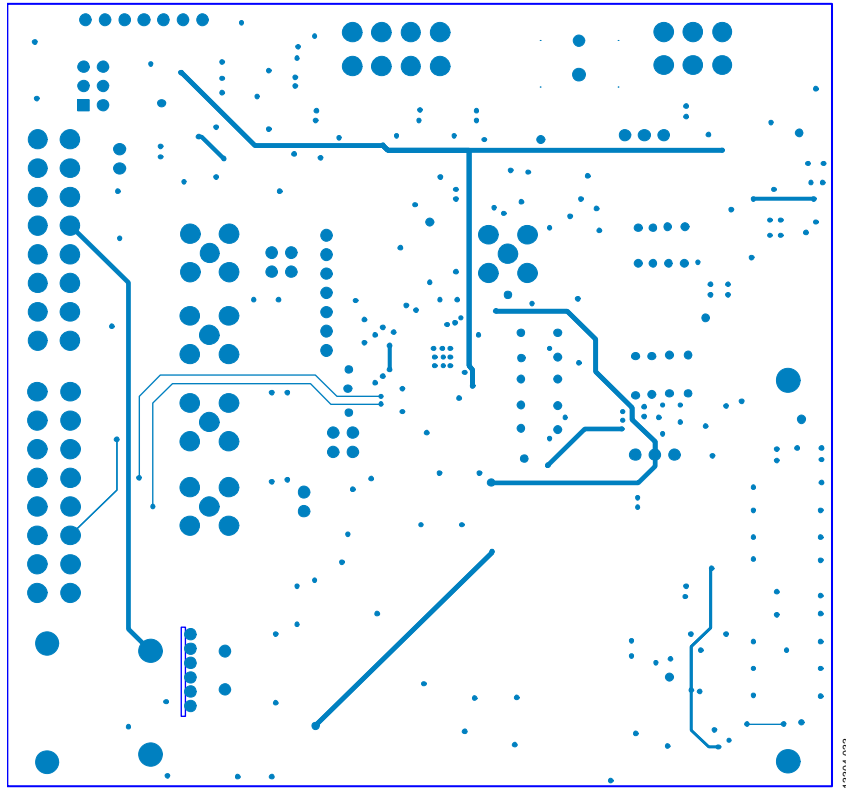

Figure 33. Layer 3—Power/Ground Plane

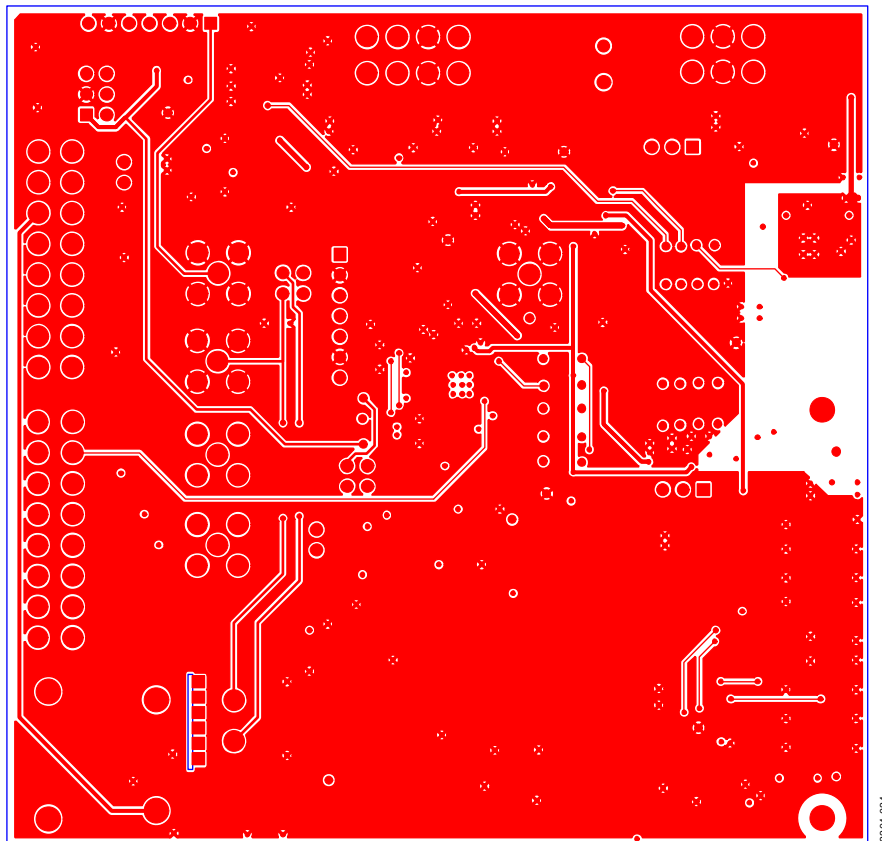

Figure 34. Layer 4—Component Side

## BILL OF MATERIALS

Table 4.

Reference Designator	Description	Manufacturer <sup>1</sup>	Part No. <sup>1</sup>	Stock Code
A0, A1, A5, A6, J2	Straight PCB mount SMB jack, keep hole clear of solder	Tyco	1-1337482-0	Do not insert
A2	Miniature thermocouple connector	Omega	PCC-SMP-U-50	Do not insert
C1, C17, C29, C30, C43, C47	Capacitor, ceramic, 6.3 V, X5R, 0603, 4.7 $\mu$ F, $\pm$ 10%	Murata	GRM188R60J475K	FEC 173-5527
C2, C22, C25, C26, C36, C38, C54, C55	Capacitor, ceramic, 50 V, X7R, 0603, 0.1 $\mu$ F, $\pm$ 10%	Murata	GRM188R71H104K	FEC 882-0023
C3, C45, C46	Capacitor, ceramic, 10 V, X5R, 0603, 4.7 $\mu$ F, $\pm$ 10%	Kemet	C0603C475K8PACTU	FEC 157-2625
C4, C6	Capacitor, 0805, 1 $\mu$ F, 50V, X7R, 1 $\mu$ F, $\pm$ 10%	Murata	GRM21BR71H105KA12L	FEC 173-5541
C5, C7, C8, C9, C16	Ceramic capacitor, not inserted, 0402	N/A	N/A	Do not insert
C10 to C12, C24, C27, C28	Ceramic capacitor, 50 V, NPO, 0603, 0.01 $\mu$ F	Phycomp	2238 586 15636	FEC 722-236
C13, C14, C18, C20, C21, C31, C33, C34, C44, C50 to C53	Capacitor, ceramic, 16 V, X7R, 0402, 0.1 $\mu$ F, $\pm$ 10%	Murata	GRM155R71C104K	FEC 881-9742
C15, C37	Capacitor, 6.3 V, 1 $\mu$ F, $\pm$ 10%	Murata	GRM188R70J105KA01D	FEC 184-5765
C19, C59	Ceramic capacitor, 25 V, NPO, 0603, 0.01 $\mu$ F	N/A	N/A	Do not insert
C23	Ceramic capacitor, 50 V, NPO, 0603, 0.1 $\mu$ F	N/A	N/A	Do not insert
C32, C35, C39, C48, C49	Capacitor, ceramic, 50 V, X5R, 1210, 10 $\mu$ F	Murata	GRM32ER61H106K	FEC 184-5764
D2, D6	Red LED, high intensity (>90 mCd), 0603	Avago Tech	HSMC-C191	FEC 855-8528
D4	LED, SMD, green	OSRAM	LGQ971	Digikey 475-1409-1-ND
D5	Diode, Zener, 0.5 W, 5.1 V, BZT52	Vishay	BZT52B5V1-V-GS08	FEC 161-7767
GND, GN1 to GND6, MCLK, REF+, REF-, REFOUT, S1 to S8, S1' to S8', TDIN, TDIN1, TDOUT, TDOUT1, TSCLK, TSCLK1, TSYNC, TSYNC1, TVCS, TVCS1	Test point, not inserted, keep hole clear of solder	N/A	N/A	Do not insert
J1	120-way connector, 0.6 mm pitch	Hirose	FX8-120S-SV(21)	FEC 132-4660
J3	Socket terminal block, 3.81 mm pitch	Phoenix Contact	MC 1.5/3-G-3.81	FEC 370-4737
J4	Screw terminal block, pitch 3.81 mm	Phoenix Contact	1727023	Do not insert
J5	DC power connectors, 2 mm, SMT, power jack	Kycon	KLDX-SMT2-0202-A	MOUSER 806-KLDX-SMT20202A
J6, J11	8-pin terminal header, pitch 3.81 mm, vertical	Phoenix Contact	MC 1,5/ 8-G-3,81	FEC 370-4774
J7	Connector, pitch 3.81 mm, right angle, 1 $\times$ 4-pin	Phoenix Contact	MC 1,5/ 4-G-3,81 and 180-3594	Do not insert
J8, J10	8-pin terminal header, pitch 3.81 mm, vertical	Phoenix Contact	1727078	Do not insert
J9	Screw terminal block, pitch 3.81 mm, 1 $\times$ 4-pin	Phoenix Contact	1727036	FEC 370-4592
J12	PCB pads, 6-way solder slot for Analog Devices PCB, 6-way	Aragorn	ADT7320-CJC-PCB	ADT7320-CJC-PCB
J13	7-way SSW, 2.54 mm vertical socket	Samtec	SSW-107-01-T-5	FEC 180-3478
J14	7-way sip, 2.54 mm, TH header	Samtec	TLW-107-05-G-5	FEC 166-8499
J15	Do not insert	N/A	N/A	Do not insert
L3	Ferrite bead, 0.3 $\Omega$ at dc, 1000 $\Omega$ at 100 MHz, 350 mA, 0805, 1000 $\Omega$	Tyco	BMB2A1000LN2	FEC 119-3421
LK1, LK2	3-pin (3 $\times$ 1), 0.1" header and shorting block in Position A	Harwin	M20-9990346 and M7566-05	FEC 102-2249 and 150-411

Reference Designator	Description	Manufacturer <sup>1</sup>	Part No. <sup>1</sup>	Stock Code
LK3, LK5	2-pin (0.1" pitch) header and shorting shunt	Harwin	M20-9990246	FEC 102-2247 and 150-411
LK4, LK6	4-pin (2x2) 0.1" header and shorting block	Harwin	M20-9983646 and M7566-05	FEC 1022244 and 150-411 (36-pin strip)
Q1	MOSFET transistor	Vishay Siliconix	SI2304DDS-T1-GE3	FEC 185-8939
Q2	Transistor, NPN, SOT-23	ON Semiconductor	MMBT3904LT1G	FEC 145-9100
R1	Resistor, not inserted, 0603	N/A	N/A	Do not insert
R2 to R4, R7, R48	SMD resistor, 100 k $\Omega$ , 1%	Multicomp	MC 0.063W 0603 1% 100K	FEC 933-0402
R5, R6, R8, R71	Resistor, 1%, 0402, 10 k $\Omega$	Phycomp	CRCW040210K0FKEAHP	FEC 173-8864
R9 to R13, R19 to R22, R35 to R38, R58, R59, R61, R62, R70	Resistor, 0402, 0 $\Omega$ , 1%	Vishay	CRCW04020000Z0ED	FEC 146-9661
R14	Resistor, 0402, 1%, 30 k $\Omega$	Multicomp	MC 0.0625W 0402 1% 30K	FEC 135-8082
R15, R17, R18, R24	SMD resistor, 10.2 k $\Omega$ , 1%	Multicomp	MC 0.0625W 0402 1% 10K2	FEC 180-3137
R16	Resistor, 0402, 1%, 69.8 k $\Omega$	Multicomp	MC 0.0625W 0402 1% 69K8	FEC 180-3735
R23	Resistor, 0402, 1%, 86.6 k $\Omega$	Multicomp	MC 0.0625W 0402 1% 86K6	FEC 180-3744
R25, R57	Resistor, 0402, 1%, 15 k $\Omega$	Multicomp	MC 0.0625W 0402 1% 15k	FEC 1358073
R26, R27, R29, R30, R32, R40	Resistor, 0603, 1 k $\Omega$ , 1%	Multicomp	MC 0.063W 0603 1% 1K	FEC 933-0380
R28	Thermistor, 1950 $\Omega$ to 1990 $\Omega$	Infineon	Q62705-K110	Philips (Arrow) KTY81/110
R31, R90	Resistor, not inserted, 0402	N/A	N/A	Do not insert
R33, R34, R39, R47, R81 to R84, R87, R89	Resistor, 0603, 0 $\Omega$ , 1%	Vishay Draloric	CRCW06030000Z0EA	FEC 146-9739
R42 to R45	Resistor, thick film, 10 k $\Omega$ , 62.5 mW, 5%	Yageo	RC0402JR-1310KL	FEC 179-9316
R49 to R52	Resistor, 1206, 0 $\Omega$ , 5%	Multicomp	MC 0.125W 1206 0R	FEC 933-6974
R53	Resistor, 0402, 27 k $\Omega$ , 1%	Multicomp	MC 0.0625W 0402 1% 27K	FEC 135-8081
R54	Resistor, thick film, 4.53 k $\Omega$ , 63 mW, 1%	Vishay Dale	CRCW04024K53FKED	FEC 115-1244
R55	Resistor, 0402, 1%, 61.9 $\Omega$	Multicomp	MC 0.0625W 0402 1% 61R9	FEC 180-2915
R56	Resistor, 0402, 57.6 k $\Omega$ , 1%	Multicomp	MC 0.0625W 0402 1% 57K6	FEC 185-1295
R60	Resistor, thick film, 2.4 k $\Omega$ , 0603, 100 mW, 1%	Yageo	RC0603FR-072K4L	FEC 179-9329
R88	Resistor, 0603, not inserted	N/A	N/A	Do not insert
SL2, SL3, SL7	2-way solder link (use 0 $\Omega$ , 0603 resistor)	N/A	Insert in Link Position A	FEC 933-1662
SL5	2-way solder link (use 0 $\Omega$ , 0603 resistor)	N/A	Insert in Link Position B	FEC 933-1662
STAR3	Ground link	N/A	N/A	N/A
U1	32k I <sup>2</sup> C serial EEPROM	Microchip	24LC32A-I/MS	FEC133-1330
U2	Linear regulator 5 V, 20 V, 500 mA, ultralow noise, CMOS	Analog Devices	<a href="#">ADP7104ARDZ-5.0</a>	<a href="#">ADP7104ARDZ-5.0</a>
U3	Quad voltage monitor and sequencer	Analog Devices	<a href="#">ADM1185ARMZ-1</a>	<a href="#">ADM1185ARMZ-1</a>
U4	50 mA, high voltage, micropower linear regulator, ADJ	Analog Devices	<a href="#">ADP1720ARMZ-R7</a>	<a href="#">ADP1720ARMZ-R7</a>
U5	4-channel, low power, low noise, $\Sigma$ - $\Delta$ ADC	Analog Devices	<a href="#">AD7124-4BCPZ</a>	<a href="#">AD7124-4BCPZ</a>
U6	2.5 V low noise reference	Analog Devices	<a href="#">ADR4525BRZ</a>	<a href="#">ADR4525BRZ</a>
U7, U10	50 mA, high voltage, micropower linear regulator, 3.3 V	Analog Devices	<a href="#">ADP1720ARMZ-3.3-R7</a>	<a href="#">ADP1720ARMZ-3.3-R7</a>
V1 to V4	1206, place holder	N/A	N/A	Do not insert

<sup>1</sup> N/A means not applicable.

NOTES

I<sup>2</sup>C refers to a communications protocol originally developed by Philips Semiconductors (now NXP Semiconductors).



**ESD Caution**

**ESD (electrostatic discharge) sensitive device.** Charged devices and circuit boards can discharge without detection. Although this product features patented or proprietary protection circuitry, damage may occur on devices subjected to high energy ESD. Therefore, proper ESD precautions should be taken to avoid performance degradation or loss of functionality.

**Legal Terms and Conditions**

By using the evaluation board discussed herein (together with any tools, components documentation or support materials, the "Evaluation Board"), you are agreeing to be bound by the terms and conditions set forth below ("Agreement") unless you have purchased the Evaluation Board, in which case the Analog Devices Standard Terms and Conditions of Sale shall govern. Do not use the Evaluation Board until you have read and agreed to the Agreement. Your use of the Evaluation Board shall signify your acceptance of the Agreement. This Agreement is made by and between you ("Customer") and Analog Devices, Inc. ("ADI"), with its principal place of business at One Technology Way, Norwood, MA 02062, USA. Subject to the terms and conditions of the Agreement, ADI hereby grants to Customer a free, limited, personal, temporary, non-exclusive, non-sublicensable, non-transferable license to use the Evaluation Board FOR EVALUATION PURPOSES ONLY. Customer understands and agrees that the Evaluation Board is provided for the sole and exclusive purpose referenced above, and agrees not to use the Evaluation Board for any other purpose. Furthermore, the license granted is expressly made subject to the following additional limitations: Customer shall not (i) rent, lease, display, sell, transfer, assign, sublicense, or distribute the Evaluation Board; and (ii) permit any Third Party to access the Evaluation Board. As used herein, the term "Third Party" includes any entity other than ADI, Customer, their employees, affiliates and in-house consultants. The Evaluation Board is NOT sold to Customer; all rights not expressly granted herein, including ownership of the Evaluation Board, are reserved by ADI. CONFIDENTIALITY. This Agreement and the Evaluation Board shall all be considered the confidential and proprietary information of ADI. Customer may not disclose or transfer any portion of the Evaluation Board to any other party for any reason. Upon discontinuation of use of the Evaluation Board or termination of this Agreement, Customer agrees to promptly return the Evaluation Board to ADI. ADDITIONAL RESTRICTIONS. Customer may not disassemble, decompile or reverse engineer chips on the Evaluation Board. Customer shall inform ADI of any occurred damages or any modifications or alterations it makes to the Evaluation Board, including but not limited to soldering or any other activity that affects the material content of the Evaluation Board. Modifications to the Evaluation Board must comply with applicable law, including but not limited to the RoHS Directive. TERMINATION. ADI may terminate this Agreement at any time upon giving written notice to Customer. Customer agrees to return to ADI the Evaluation Board at that time. LIMITATION OF LIABILITY. THE EVALUATION BOARD PROVIDED HEREUNDER IS PROVIDED "AS IS" AND ADI MAKES NO WARRANTIES OR REPRESENTATIONS OF ANY KIND WITH RESPECT TO IT. ADI SPECIFICALLY DISCLAIMS ANY REPRESENTATIONS, ENDORSEMENTS, GUARANTEES, OR WARRANTIES, EXPRESS OR IMPLIED, RELATED TO THE EVALUATION BOARD INCLUDING, BUT NOT LIMITED TO, THE IMPLIED WARRANTY OF MERCHANTABILITY, TITLE, FITNESS FOR A PARTICULAR PURPOSE OR NON-INFRINGEMENT OF INTELLECTUAL PROPERTY RIGHTS. IN NO EVENT WILL ADI AND ITS LICENSORS BE LIABLE FOR ANY INCIDENTAL, SPECIAL, INDIRECT, OR CONSEQUENTIAL DAMAGES RESULTING FROM CUSTOMER'S POSSESSION OR USE OF THE EVALUATION BOARD, INCLUDING BUT NOT LIMITED TO LOST PROFITS, DELAY COSTS, LABOR COSTS OR LOSS OF GOODWILL. ADI'S TOTAL LIABILITY FROM ANY AND ALL CAUSES SHALL BE LIMITED TO THE AMOUNT OF ONE HUNDRED US DOLLARS (\$100.00). EXPORT. Customer agrees that it will not directly or indirectly export the Evaluation Board to another country, and that it will comply with all applicable United States federal laws and regulations relating to exports. GOVERNING LAW. This Agreement shall be governed by and construed in accordance with the substantive laws of the Commonwealth of Massachusetts (excluding conflict of law rules). Any legal action regarding this Agreement will be heard in the state or federal courts having jurisdiction in Suffolk County, Massachusetts, and Customer hereby submits to the personal jurisdiction and venue of such courts. The United Nations Convention on Contracts for the International Sale of Goods shall not apply to this Agreement and is expressly disclaimed.

©2015 Analog Devices, Inc. All rights reserved. Trademarks and registered trademarks are the property of their respective owners.  
UG13304-0-7/15(0)



www.analog.com

## Looking for pricing, stock, or lifecycle information?

Click below to explore more details on WIN SOURCE:

- ⊖ [View EVAL-AD7124-4SDZ on WIN SOURCE](#)
- ⊖ [Analog Devices Inc. Information](#)

## Optimize Your Supply Chain with WIN SOURCE Solutions

- ✓ Global Sourcing Solution
- ✓ Obsolete Management
- ✓ Cost Control Management
- ✓ Shortage Management
- ✓ Alternative Solution
- ✓ Excess Inventory Management