



THE DATASHEET OF CA3059



FEATURES AND APPLICATIONS OF INTEGRATED CIRCUIT ZERO-VOLTAGE SWITCHES (CA3059 AND CA3079)

Authors: A.C.N. Sheng, G.J. Granieri, J. Yellin, and T. McNulty

CA3059 and CA3079 zero-voltage switches are monolithic integrated circuits designed primarily for use as trigger circuits for thyristors in many highly diverse AC power control and power switching applications. These integrated circuit switches operate from an AC input voltage of 24, 120, 208 to 230, or 277V at 50, 60, or 400Hz.

The CA3059 and CA3079 are supplied in a 14 terminal dual-in-line plastic package.

Zero-voltage switches (ZVS) are particularly well suited for use as thyristor trigger circuits. These switches trigger the thyristors at zero-voltage points in the supply voltage cycle. Consequently, transient load current surges and radio frequency interference (RFI) are substantially reduced. In addition, use of the zero-voltage switches also reduces the rate of change of on state current (di/dt) in the thyristor being triggered, an important consideration in the operation of thyristors. These switches can be adapted for use in a variety of control functions by use of an internal differential comparator to detect the difference between two externally developed voltages. In addition, the availability of numerous terminal connections to internal circuit points greatly increases circuit flexibility and further expands the types of AC power control applications to which these integrated circuits may be adapted. The excellent versatility of the zero-voltage switches is demonstrated by the fact that these circuits have been used to provide transient free temperature control in self cleaning ovens, to control gun muzzle temperature in low temperature environments, to provide sequential switching of heating elements in warm air furnaces, to switch traffic signal lights at street intersections, and to effect other widely different AC power control functions.

Functional Description

Zero-voltage switches are multistage circuits that employ a diode limiter, a zero crossing (threshold) detector, an on/off sensing amplifier (differential comparator), and a Darlington output driver (thyristor gating circuit) to provide the basic switching action. The DC operating voltages for these stages is provided by an internal power supply that has sufficient current capability to drive external circuit elements, such as transistors and other integrated circuits. An important feature of the zero-voltage switches is that the output trigger pulses can be applied directly to the gate of a triac or a silicon controlled rectifier (SCR). The CA3059 features an interlock (protection) circuit

that inhibits the application of these pulses to the thyristor in the event that the external sensor should be inadvertently opened or shorted. An external inhibit connection (terminal No. 1) is also available so that an external signal can be used to inhibit the output drive. This feature is not included in the CA3079; otherwise, the three integrated circuit zero-voltage switches are electrically identical.

Overall Circuit Operation

Figure 1 shows the functional interrelation of the zero-voltage switch, the external sensor, the thyristor being triggered, and the load elements in an on/off type of AC power control system. As shown, each of the zero-voltage switches incorporates four functional blocks as follows:

Limiter Power Supply - Permits operation directly from an AC line.

Differential On/Off Sensing Amplifier - Tests the condition of external sensors or command signals. Hysteresis or proportional control capability may easily be implemented in this section.

Zero Crossing Detector - Synchronizes the output pulses of the circuit at the time when the AC cycle is at a zero-voltage point and thereby eliminates radio frequency interference (RFI) when used with resistive loads.

Triac Gating Circuit - Provides high current pulses to the gate of the power controlling thyristor.

In addition, the CA3059 provides the following important auxiliary functions (shown in Figure 1):

1. A built-in protection circuit that may be actuated to remove drive from the triac if the sensor opens or shorts.
2. Thyristor firing may be inhibited through the action of an internal diode gate connected to terminal 1.
3. High power DC comparator operation is provided by overriding the action of the zero crossing detector. This override is accomplished by connecting terminal 12 to terminal 7. Gate current to the thyristor is continuous when terminal 13 is positive with respect to terminal 9.

Figure 2 shows the detailed circuit diagram for the integrated circuit zero-voltage switches. (The diagrams shown in Figures 1 and 2 are representative of all three zero-voltage switches, i.e., the CA3059 and CA3079; the shaded areas indicate the circuitry that is not included in the CA3079.)

Application Note 6182

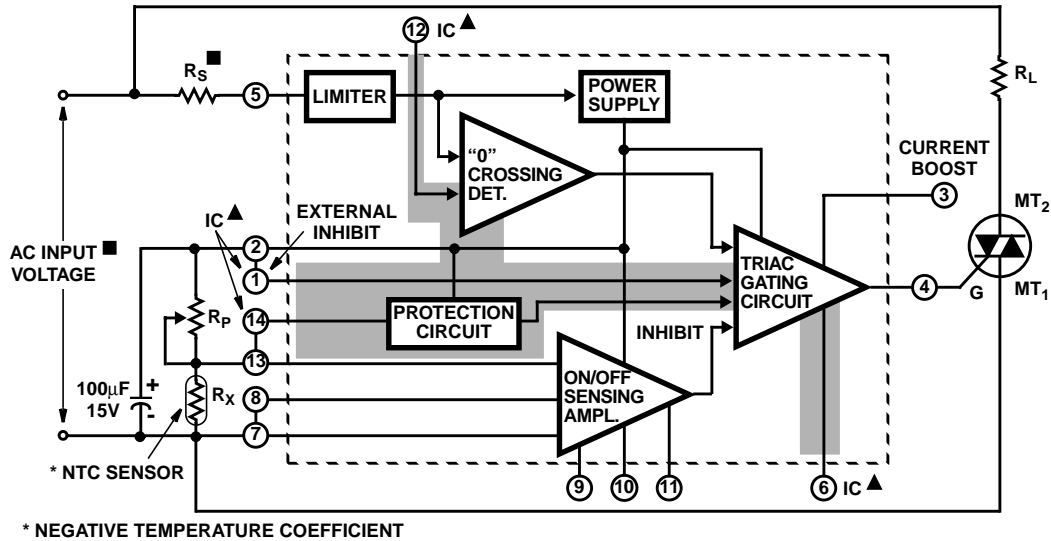

AC INPUT VOLTAGE (50/60 OR 400Hz) (V AC)	INPUT SERIES RESISTOR (R _S) (kΩ)	DISSIPATION RATING FOR R _S (W)
24	2	0.5
120	10	2
208/230	20	4
277	25	5

NOTE: Circuitry within shaded areas, not included in CA3079

■ See chart

▲ IC = Internal connection - DO NOT USE (CA3079 only)

FIGURE 1. FUNCTIONAL BLOCK DIAGRAMS OF THE ZERO-VOLTAGE SWITCHES CA3059 AND CA3079

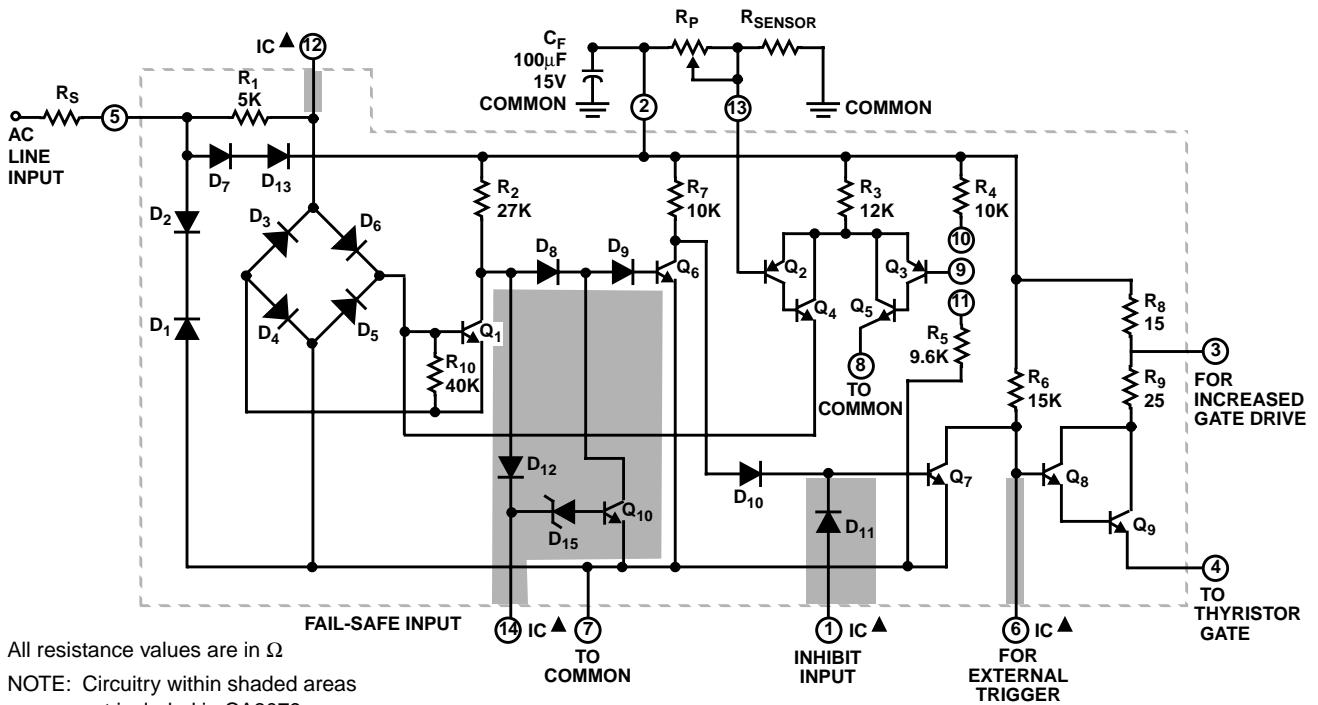

FIGURE 2. SCHEMATIC DIAGRAM OF ZERO-VOLTAGE SWITCHES CA3059 AND CA3079

The limiter stage of the zero-voltage switch clips the incoming AC line voltage to approximately $\pm 8V$. This signal is then applied to the zero-voltage crossing detector, which generates an output pulse each time the line voltage passes through zero. The limiter output is also applied to a rectifying diode and an external capacitor, C_F , that comprise the DC power supply. The power supply provides approximately 6V as the V_{CC} supply to the other stages of the zero-voltage switch. The on/off sensing amplifier is basically a differential comparator. The thyristor gating circuit contains a driver for direct triac triggering. The gating circuit is enabled when all the inputs are at a "high" voltage, i.e., the line voltage must be approximately zero volts, the sensing amplifier output must be "high", the external voltage to terminal 1 must be a logical "0", and, for the CA3059, the output of the fail-safe circuit must be "high". Under these conditions, the thyristor (triac or SCR) is triggered when the line voltage is essentially zero volts.

Thyristor Triggering Circuits

The diodes D_1 and D_2 in Figure 2 form a symmetrical clamp that limits the voltages on the chip to $\pm 8V$; the diodes D_7 and D_{13} form a half-wave rectifier that develops a positive voltage on the external storage capacitor, C_F .

The output pulses used to trigger the power switching thyristor are actually developed by the zero crossing detector and the thyristor gating circuit. The zero crossing detector consists of diodes D_2 and through D_6 , transistor Q_1 , and the associated resistors shown in Figure 2. Transistors Q_1 and Q_6 through Q_9 and the associated resistors comprise the thyristor gating circuit and output driver. These circuits generate the output pulses when the AC input is at a zero-voltage point so that RFI is virtually eliminated when the zero-voltage switch and thyristor are used with resistive loads.

The operation of the zero crossing detector and thyristor gating circuit can be explained more easily if the on state (i.e., the operating state in which current is being delivered to the thyristor gate through terminal 4) is considered as the operating condition of the gating circuit. Other circuit elements in the zero-voltage switch inhibit the gating circuit unless certain conditions are met, as explained later.

In the on state of the thyristor gating circuit, transistors Q_8 and Q_9 are conducting, transistor Q_7 is off, and transistor Q_6 is on. Any action that turns on transistor Q_7 removes the drive from transistor Q_8 and thereby turns off the thyristor. Transistor Q_7 may be turned on directly by application of a minimum of $\pm 1.2V$ at $10\mu A$ to the external inhibit input, terminal 1. (If a voltage of more than 1.5V is available, an external resistance must be added in series with terminal 1 to limit the current to 1mA.) Diode D_{10} isolates the base of transistor Q_7 from other signals when an external inhibit signal is applied so that this signal is the highest priority command for normal operation. (Although grounding of terminal 6 creates a higher priority inhibit function, this level is not compatible with normal DTL or TTL logic levels.) Transistor Q_7 may also be activated by turning off transistor Q_6 to allow current flow from the power supply through resistor R_7 and diode D_{10} into the base of Q_7 . Transistor Q_6 is normally maintained in con-

duction by current that flows into its base through resistor R_2 and diodes D_8 and D_9 when transistor Q_1 is off.

Transistor Q_1 is a portion of the zero crossing detector. When the voltage at terminal 5 is greater than +3V, current can flow through resistor R_1 , diode D_6 , the base-to-emitter junction of transistor Q_1 , and diode D_4 to terminal 7 to turn on Q_1 . This action inhibits the delivery of a gate-drive output signal at terminal 4. For negative voltages at terminal 5 that have magnitudes greater than 3V, the current flows through diode D_5 , the emitter-to-base junction of transistor Q_1 , diode D_3 , and resistor R_1 , and again turns on transistor Q_1 . Transistor Q_1 is off only when the voltage at terminal 5 is less than the threshold voltage of approximately $\pm 2V$. When the integrated circuit zero-voltage switch is connected as shown in Figure 2, therefore, the output is a narrow pulse which is approximately centered about the zero-voltage time in the cycle, as shown in Figure 3. In some applications, however, particularly those that use either slightly inductive or low power loads, the thyristor load current does not reach the latching current value† by the end of this pulse. An external capacitor C_X connected between terminal 5 and 7, as shown in Figure 4, can be used to delay the pulse to accommodate such loads. The amount of pulse stretching and delay is shown in Figures 5(a) and 5(b).

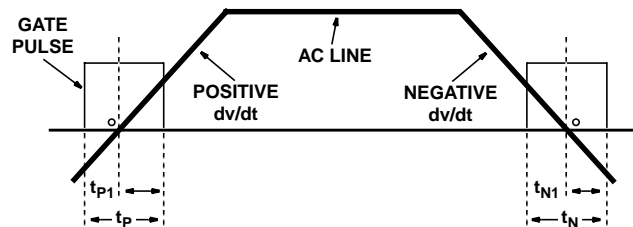

FIGURE 3. WAVEFORM SHOWING OUTPUT PULSE DURATION OF THE ZERO-VOLTAGE SWITCH.

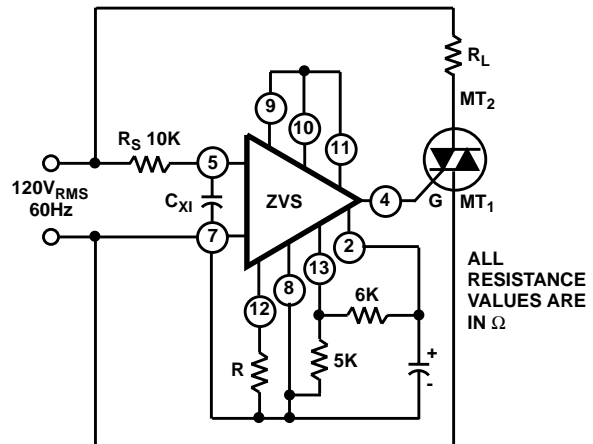

FIGURE 4. USE OF A CAPACITOR BETWEEN TERMINALS 5 AND 7 TO DELAY THE OUTPUT PULSE OF THE ZERO-VOLTAGE SWITCH

† The latching current is the minimum current required to sustain conduction immediately after the thyristor is switched from the off to the on state and the gate signal is removed.

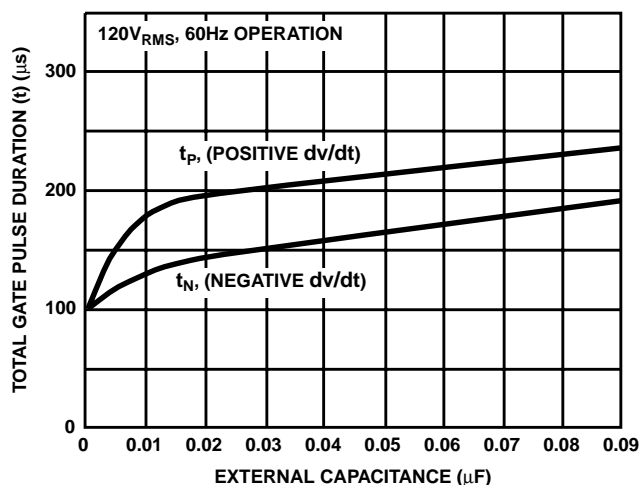

FIGURE 5A.

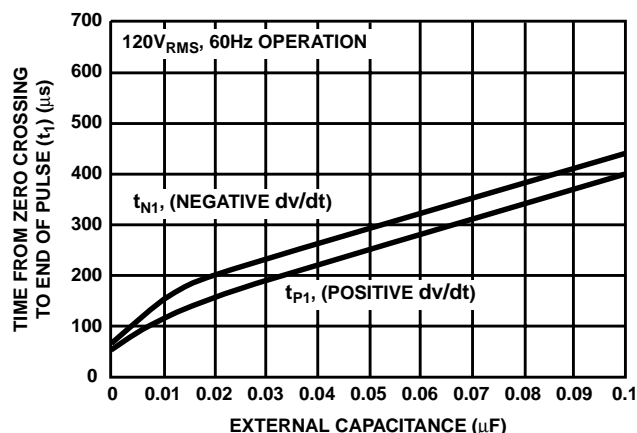

FIGURE 5B.

FIGURE 5. CURVES SHOWING EFFECT OF EXTERNAL CAPACITANCE ON A. THE TOTAL OUTPUT PULSE DURATION, AND B. THE TIME FROM ZERO CROSSING TO THE END OF THE PULSE

Continuous gate current can be obtained if terminal 12 is connected to terminal 7 to disable the zero crossing detector. In this mode, transistor Q_1 is always off. This mode of operation is useful when comparator operation is desired or when inductive loads must be switched. (If the capacitance in the load circuit is low, most RFI is eliminated.) Care must be taken to avoid overloading of the internal power supply in this mode. A sensitive gate thyristor should be used, and a resistor should be placed between terminal 4 and the gate of the thyristor to limit the current, as pointed out later under Special Application Considerations.

Special Application Considerations

Figure 6 indicates the timing relationship between the line voltage and the zero-voltage switch output pulses. At 60Hz, the pulse is typically $100\mu\text{s}$ wide; at 400Hz, the pulse width is typically $12\mu\text{s}$. In the basic circuit shown, when the DC logic signal is "high", the output is disabled; when it is "low", the gate pulses are enabled.

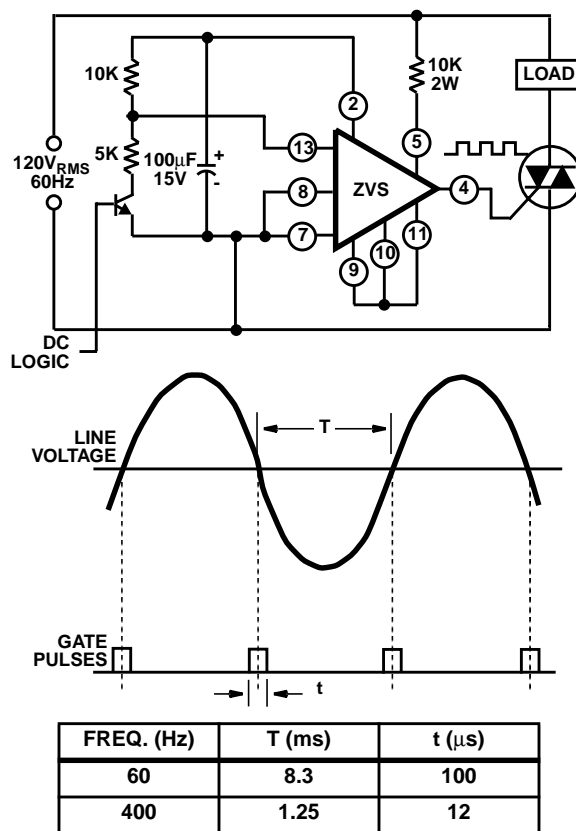

FIGURE 6. TIMING RELATIONSHIP BETWEEN THE OUTPUT PULSES OF THE ZERO-VOLTAGE SWITCH AND THE AC LINE VOLTAGE

On/Off Sensing Amplifier

The discussion thus far has considered only cases in which pulses are present all the time or not at all. The differential sense amplifier consisting of transistors Q_2 , Q_3 , Q_4 , and Q_5 (shown in Figure 2) makes the zero-voltage switch a flexible power control circuit. The transistor pairs Q_2 - Q_4 and Q_3 - Q_5 form a high beta composite p-n-p transistors in which the emitters of transistors Q_4 and Q_5 act as the collectors of the composite devices. These two composite transistors are connected as a differential amplifier with resistor R_3 acting as a constant current source. The relative current flow in the two "collectors" is a function of the difference in voltage between the bases of transistors Q_2 and Q_3 . Therefore, when terminal 13 is more positive than terminal 9, little or no current flows in the "collector" of the transistor pair Q_2 - Q_4 . When terminal 13 is negative with respect to terminal 9, most of the current flows through that path, and none in terminal 8. When current flows in the transistor pair Q_2 - Q_4 , through the base emitter junction of transistor Q_1 , and finally through the diode D_4 to terminal 7. Therefore, when V_{13} is equal to or more negative than V_9 , transistor Q_1 is on, and the output is inhibited.

In the circuit shown in Figure 1, the voltage at terminal 9 is derived from the supply by connection of terminals 10 and 11 to form a precision voltage divider. This divider forms one side of a transducer bridge, and the potentiometer R_p and the negative temperature coefficient (NTC) sensor form the other side. At

Application Note 6182

low temperatures, the high resistance of the sensor causes terminal 13 to be positive with respect to terminal 9 so that the thyristor fires on every half cycle, and power is applied to the load. As the temperature increases, the sensor resistance decreases until a balance is reached, and V_{13} approaches V_9 . At this point, the transistor pair Q_2 - Q_4 turns on and inhibits any further pulses. The controlled temperature is adjusted by variation of the value of the potentiometer R_P . For cooling service, either the positions of R_P and the sensor may be reversed or terminals 9 and 13 may be interchanged.

The low bias current of the sensing amplifier permits operation with sensor impedances of up to $0.1M\Omega$ at balance without introduction of substantial error (i.e., greater than 5 percent). The error may be reduced if the internal bridge elements, resistors R_4 and R_5 , are not used, but are replaced with resistances which equal the sensor impedance. The minimum value of sensor impedance is restricted by the current drain on the internal power supply. Operation of the zero-voltage switch with low impedance sensors is discussed later under Special Application Considerations. The voltage applied to terminal 13 must be greater than 1.8V at all times to assure proper operation.

Protection Circuit

A special feature of the CA3059 zero-voltage switch is the inclusion of an interlock type of circuit. This circuit removes power from the load by interrupting the thyristor gate drive if the sensor either shorts or opens. However, use of this circuit places certain constraints upon the user. Specifically, effective protection circuit operation is dependent upon the following conditions:

1. The circuit configuration of Figure 1 is used, with an internal supply, no external load on the supply, and terminal 14 connected to terminal 13.
2. The value of potentiometer R_P and of the sensor resistance must be between 2000Ω and $0.1M\Omega$.
3. The ratio of sensor resistance and R_P must be greater than 0.33 and less than 3.0 for all normal conditions. (If either of these ratios is not met with an unmodified sensor, a series resistor or a shunt resistor must be added to avoid undesired activation of the circuit.)

The protective feature may be applied to other systems when operation of the circuit is understood. The protection circuit consists of diodes D_{12} and D_{15} and transistor Q_{10} . Diode D_1 activates the protection circuit if the sensor shown in Figure 1 shorts or its resistance drops too low in value, as follows: Transistor Q_6 is on during an output pulse so that the junction of diodes D_8 and D_{12} is 3 diode drops (approximately 2V) above terminal 7. As long as V_{14} is more positive or only 0.15 volt negative with respect to that point, diode D_{12} does not conduct, and the circuit operates normally. If the voltage at terminal 14 drops to 1 volt, the anode of diode D_8 can have a potential of only 1.6 to 1.7V, and current does not flow through diodes D_8 and D_9 and transistor Q_6 . The thyristor then turns off.

The actual threshold is approximately 1.2V at room temperature, but decreases 4mV per degree C at higher

temperatures. As the sensor resistance increases, the voltage at terminal 14 rises toward the supply voltage. At a voltage of approximately 6V, the zener diode D_{15} breaks down and turns on transistor Q_{10} , which then turns off transistor Q_6 and the thyristor. If the supply voltage is not at least 0.2 volt more positive than the breakdown voltage of diode D_{15} , activation of the protection circuit is not possible. For this reason, loading the internal supply may cause this circuit to malfunction, as may the selection of the wrong external supply voltage. Figure 7 shows a guide for the proper operation of the protection circuit when an external supply is used with a typical integrated circuit zero-voltage switch.

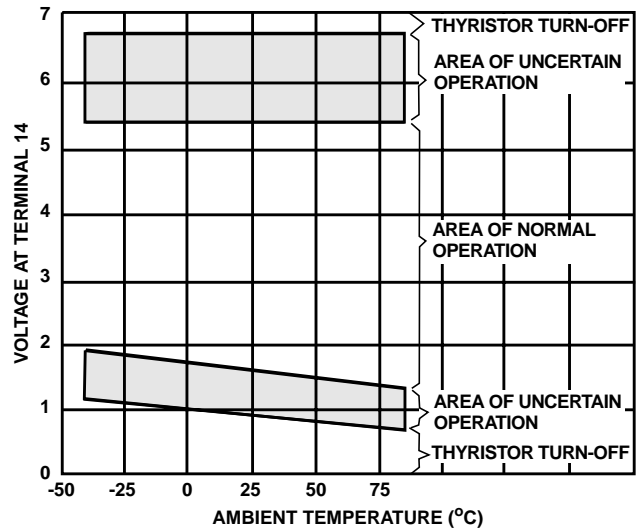

FIGURE 7. OPERATING REGIONS FOR BUILT-IN PROTECTION CIRCUITS OF A TYPICAL ZERO-VOLTAGE SWITCH.

Special Application Considerations

As pointed out previously, the Intersil integrated circuit zero-voltage switches (CA3059 and CA3079) are exceptionally versatile units than can be adapted for use in a wide variety of power control applications. Full advantage of this versatility can be realized, however, only if the user has a basic understanding of several fundamental considerations that apply to certain types of applications of the zero-voltage switches.

Operating Power Options

Power to the zero-voltage switch may be derived directly from the AC line, as shown in Figure 1, or from an external DC power supply connected between terminals 2 and 7, as shown in Figure 8. When the zero-voltage switch is operated directly from the AC line, a dropping resistor R_S of $5,000\Omega$ to $10,000\Omega$ must be connected in series with terminal 5 to limit the current in the switch circuit. The optimum value for this resistor is a function of the average current drawn from the internal DC power supply, either by external circuit elements or by the thyristor trigger circuits, as shown in Figure 9. The chart shown in Figure 1 indicates the value and dissipation rating of the resistor R_S for AC line voltages 24, 120, 208 to 230, and 277V.

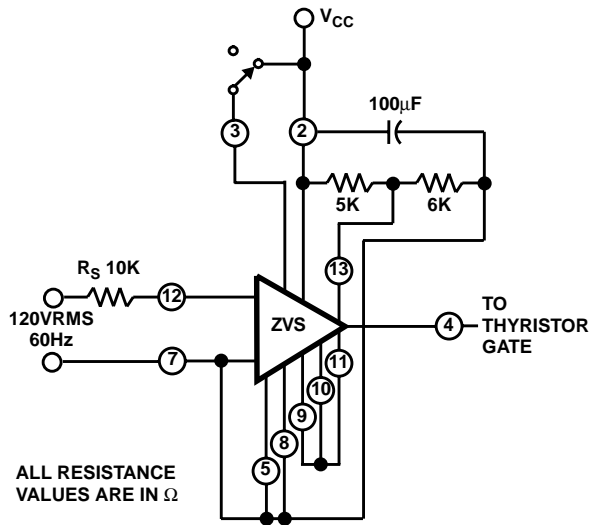

FIGURE 8. OPERATION OF THE ZERO-VOLTAGE SWITCH FROM AN EXTERNAL DC POWER SUPPLY CONNECTED BETWEEN TERMINALS 2 AND 7.

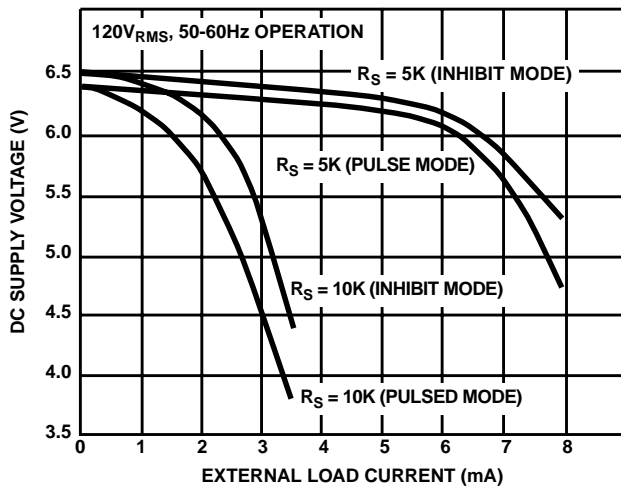

FIGURE 9. DC SUPPLY VOLTAGE AS A FUNCTION OF EXTERNAL LOAD CURRENT FOR SEVERAL VALUES

Half Cycling Effect

The method by which the zero-voltage switch senses the zero crossing of the AC power results in a half cycling phenomenon at the control point. Figure 10 illustrates this phenomenon. The zero-voltage switch senses the zero-voltage crossing every half cycle, and an output, for example pulse No. 4, is produced to indicate the zero crossing. During the remaining 8.3ms, however, the differential amplifier in the zero-voltage switch may change state and inhibit any further output pulses. The uncertainty region of the differential amplifier, therefore, prevents pulse No. 5 from triggering the triac during the negative excursion of the AC line voltage.

When a sensor with low sensitivity is used in the circuit, the zero-voltage switch is very likely to operate in the linear

mode. In this mode, the output trigger current may be sufficient to trigger the triac on the positive going cycle, but insufficient to trigger the device on the negative going cycle of the triac supply voltage. This effect introduces a half cycling phenomenon, i.e., the triac is turned on during the positive half cycle and turned off during the negative half cycle.

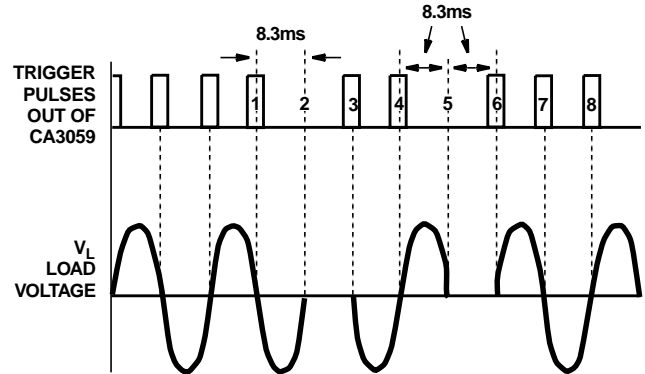
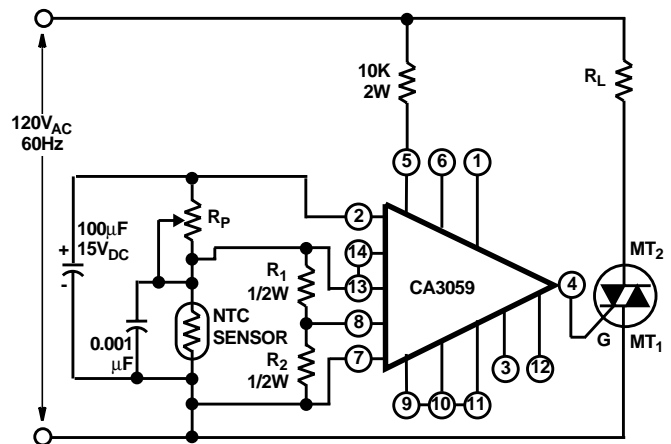

FIGURE 10. HALF CYCLING PHENOMENON IN THE ZERO-VOLTAGE SWITCH

Several techniques may be used to cope with the half cycling phenomenon. If the user can tolerate some hysteresis in the control, then positive feedback can be added around the differential amplifier. Figure 11 illustrates this technique. The tabular data in the figure lists the recommended values of resistors R1 and R2 for different sensor impedances at the control point.



THERMISTOR →

NTC	R1	R2
5K	12K	12K
12K	68K	12K
100K	200K	18K

FIGURE 11. CA3059 ON-OFF CONTROLLER WITH HYSTERESIS

If a significant amount (greater than ±10%) of controlled hysteresis is required, then the circuit shown in Figure 12 may be employed. In this configuration, external transistor Q1 can be used to provide an auxiliary timed delay function.

Application Note 6182

TROLLED HYSTERESIS

For applications that require complete elimination of half cycling without the addition of hysteresis, the circuit shown in Figure 13 may be employed. This circuit uses a CA3098E integrated circuit programmable comparator with a zero-voltage switch. A block diagram of CA3098E is shown in Figure 14. Because the CA3098E contains an integral flip-flop, its output will be in either a "0" or "1" state. Consequently the zero-voltage switch cannot operate in the linear mode, and spurious half cycling operation is prevented. When the signal input voltage at terminal 8 of the CA3098E is equal to or less than the "low" reference voltage (LR), current flows from the power supply through resistor R_1 and R_2 , and a logic "0" is applied to terminal 13 of the zero-voltage switch. This condition turns off the triac. The triac remains off until the signal input voltage rises to or exceeds the "high" reference voltage (HR), thereby effecting a change in the state of the flip-flop so that a logic "1" is

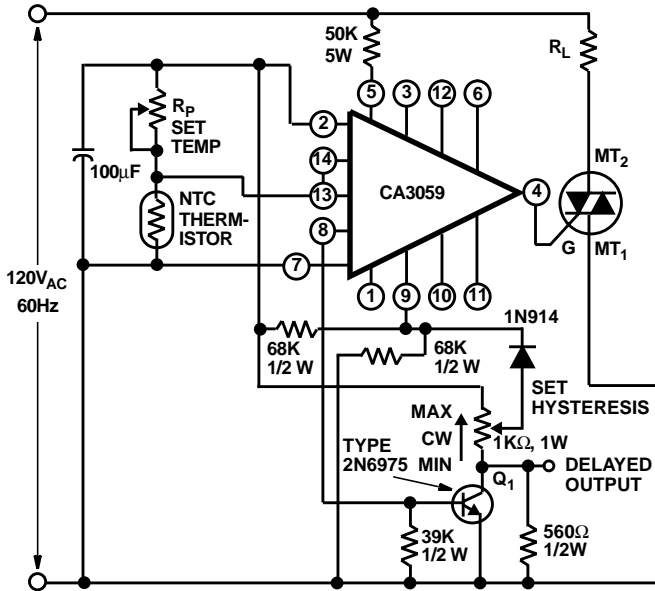

FIGURE 12. CA3059 ON/OFF CONTROLLER WITH CON-

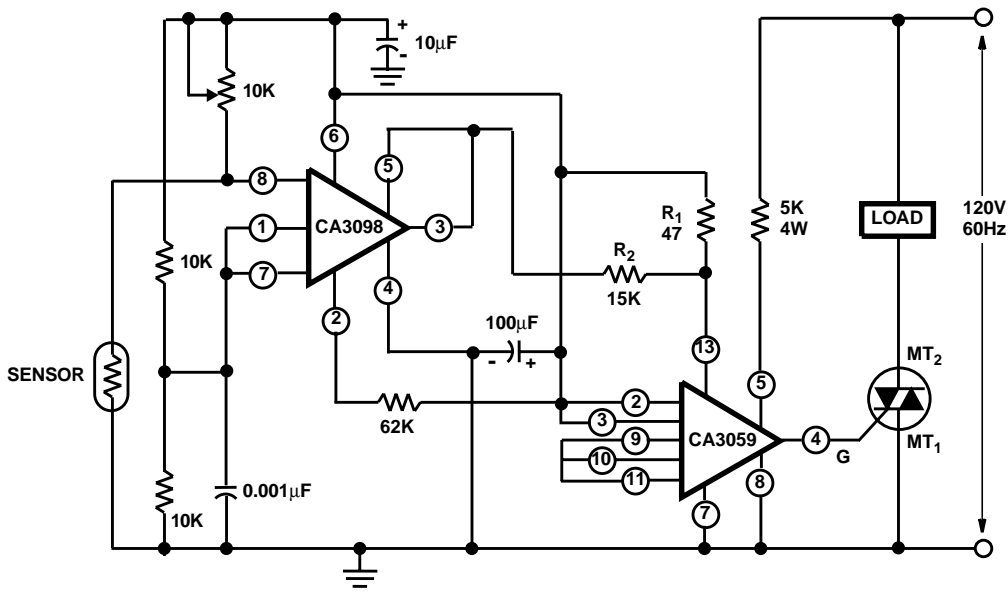
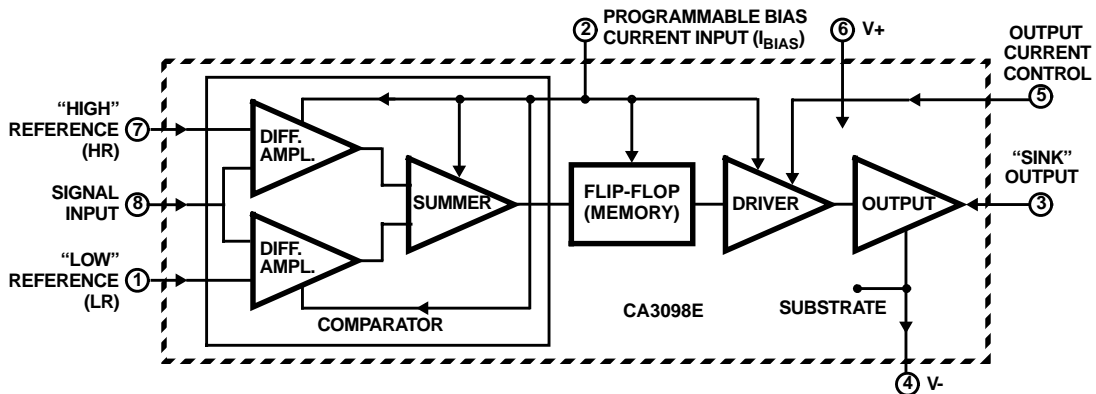

FIGURE 13. SENSITIVE TEMPERATURE CONTROL



applied to terminal 13 of the zero-voltage switch, and triggers the triac on.

“Proportional Control” Systems

The on/off nature of the control shown in Figure 1 causes some overshoot that leads to a definite steady state error. The addition of hysteresis adds further to this error factor. However, the connections shown in Figure 15A. can be used to add proportional control to the system. In this circuit, the sense amplifier is connected as a free running multivibrator. At balance, the voltage at terminal 13 is much less than the voltage at terminal 9. The output will be inhibited at all times until the voltage at terminal 13 rises to the design differential voltage between terminals 13 and 9; then proportional control resumes. The voltage at terminal 13 is as shown in Figure 15B). When this voltage is more positive than the threshold, power is applied to the load so that the duty cycle is approximately 50 percent. With a 0.1MΩ sensor and values of $R_P = 0.1M\Omega$, $R_2 = 10,000\Omega$, and $C_{EXT} = 10\mu F$, a period greater than 3 seconds is achieved. This period should be much shorter than the thermal time constant of the system. A change in the value of any of these elements changes the period, as shown in Figure 16. As the resistance of the sensor changes, the voltage on terminal 13 moves relative to V_9 . A cooling sensor moves V_{13} in a positive direction. The triac is on for a larger portion of the pulse cycle and increases the average power to the load.

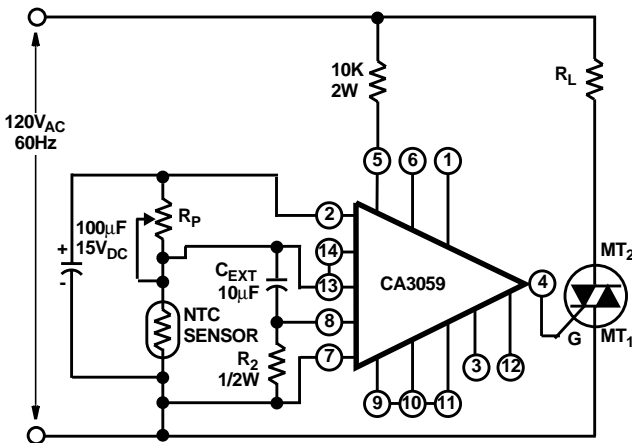

FIGURE 15A.

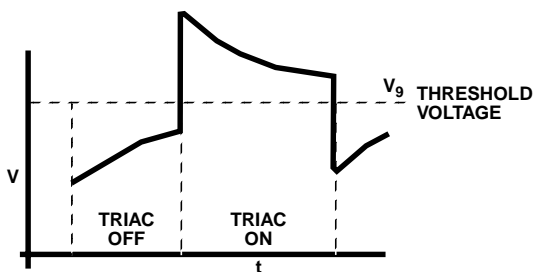
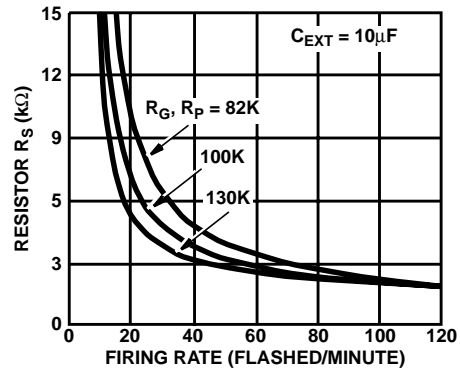

FIGURE 15B.

FIGURE 15. USE OF THE CA3059 IN A TYPICAL HEATING CONTROL WITH PROPORTIONAL CONTROL: A.



SCHMATIC DIAGRAM, AND B. WAVEFORM OF VOLTAGE AT ERMINAL 13

FIGURE 16. EFFECT OF VARIATIONS IN TIME CONSTANT ELEMENTS ON PERIOD

As in the case of the hysteresis circuitry described earlier, some special applications may require more sophisticated systems to achieve either very precise regions of control or very long periods.

Zero-voltage switching control can be extended to applications in which it is desirable to have constant control of the temperature and a minimization of system hysteresis. A closed loop top burner control in which the temperature of the cooking utensil is sensed and maintained at a particular value is a good example of such an application; the circuit for this control is shown in Figure 17. In this circuit, a unijunction oscillator is outboarded from the basic control by means of the internal power supply of the zero-voltage switch. The output of this ramp generator is applied to terminal 9 of the zero-voltage switch and establishes a varied reference to the differential amplifier. Therefore, gate pulses are applied to the triac whenever the voltage at terminal 13 is greater than the voltage at terminal 9. A varying duty cycle is established in which the load is predominantly on with a cold sensor and predominantly off with a hot sensor. For precise temperature regulation, the time base of the ramp should be shorter than the thermal time constant of the system but longer than the period of the 60Hz line. Figure 18, which contains various waveforms for the system of Figure 17, indicates that a typical variance of $\pm 0.5^{\circ}C$ might be expected at the sensor contact to the utensil. Overshoot of the set temperature is minimized with approach,

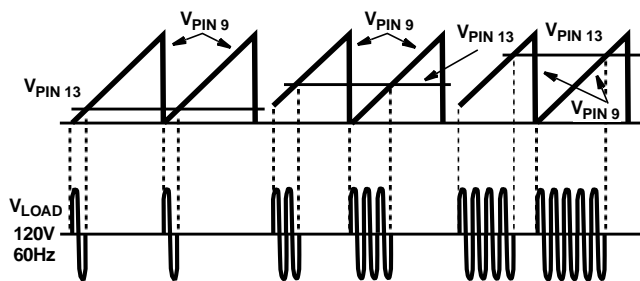

and scorching of any type is minimized.

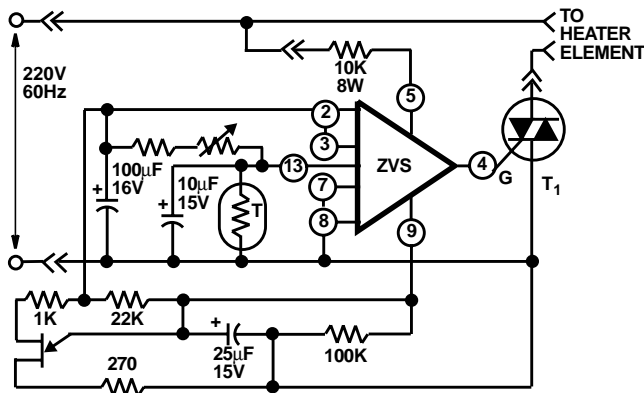

FIGURE 17. SCHEMATIC DIAGRAM OF PROPORTIONAL ZERO-VOLTAGE SWITCHING CONTROL

FIGURE 18. WAVEFORMS FOR THE CIRCUIT OF FIGURE 17.

Effect of Thyristor Load Characteristics

The zero-voltage switch is designed primarily to gate a thyristor that switches a resistive load. Because the output pulse supplied by the switch is of short duration, the latching current of the triac becomes a significant factor in determining whether other types of loads can be switched. (The latching current value determines whether the triac will remain in conduction after the gate pulse is removed.) Provisions are included in the zero-voltage switch to accommodate inductive loads and low power loads. For example, for loads that are less than approximately $4A_{rms}$ or that are slightly inductive, it is possible to retard the output pulse with respect to the zero-voltage crossing by insertion of the capacitor C_X from terminal 5 to terminal 7. The insertion of capacitor C_X permits switching of triac loads that have a slight inductive component and that are greater than approximately 200W (for operation from an AC line voltage of $120V_{rms}$). However, for loads less than 200W (for example, 70W), it is recommended that the user employ sensitive gate triacs with the zero-voltage switch because of the low latching current requirement of this triac.

For loads that have a low power factor, such as a solenoid valve, the user may operate the zero-voltage switch in the DC mode. In this mode, terminal 12 is connected to terminal 7, and the zero crossing detector is inhibited. Whether a "high" or "low" voltage is produced at terminal 4 is then dependent only upon the state of the differential comparator

within the integrated circuit zero-voltage switch, and not upon the zero crossing of the incoming line voltage. Of course, in this mode of operation, the zero-voltage switch no longer operates as a zero-voltage switch. However, for many applications that involve the switching of low current inductive loads, the amount of RFI generated can frequently be tolerated.

For switching of high current inductive loads, which must be turned on at zero line current, the triggering technique employed in the dual output over-temperature controller and the transient free switch controller described subsequently in this Note is recommended.

Switching of Inductive Loads

For proper driving of a thyristor in full cycle operation, gate drive must be applied soon after the voltage across the device reverses. When resistive loads are used, this reversal occurs as the line voltage reverses. With loads of other power factors, however, it occurs as the current through the load becomes zero and reverses.

There are several methods for switching an inductive load at the proper time. If the power factor of the load is high (i.e., if the load is only slightly inductive), the pulse may be delayed by addition of a suitable capacitor between terminals 5 and 7, as described previously. For highly inductive loads, however, this method is not suitable, and different techniques must be used.

If gate current is continuous, the triac automatically commutates because drive is always present when the voltage reverses. This mode is established by connection of terminals 7 and 12. The zero crossing detector is then disabled so that current is supplied to the triac gate whenever called for by the sensing amplifier. Although the RFI eliminating function of the zero-voltage switch is inhibited when the zero crossing detector is disabled, there is no problem if the load is highly inductive because the current in the load cannot change abruptly.

Circuits that use a sensitive gate triac to shift the firing point of the power triac by approximately 90 degrees have been designed. If the primary load is inductive, this phase shift corresponds to firing at zero current in the load. However, changes in the power factor of the load or tolerances of components will cause errors in this firing time.

The circuit shown in Figure 19 uses a CA3086 integrated circuit transistor array to detect the absence of load current by sensing the voltage across the triac. The internal zero crossing detector is disabled by connection of terminal 12 to terminal 7, and control of the output is made through the external inhibit input, terminal 1. The circuit permits an output only when the voltage at point A exceeds two V_{BE} drops, or 1.3V. When A is positive, transistors Q_3 and Q_4 conduct and reduce the voltage at terminal 1 below the inhibit state. When A is negative, transistors Q_1 and Q_2 conduct. When the voltage at point A is less than $\pm 1.3V$, neither of the transistor pairs conducts; terminal 1 is then pulled positive by the current in resistor R_3 , and the output is inhibited.

Application Note 6182

The circuit shown in Figure 19 forms a pulse of gate current and can supply high peak drive to power triacs with low average current drain on the internal supply. The gate pulse will always last just long enough to latch the thyristor so that there is no problem with delaying the pulse to an optimum time. As in other circuits of this type, RFI results if the load is not suitable inductive because the zero crossing detector is disabled and initial turn on occurs at random.

The gate pulse forms because the voltage at point A when the thyristor is on is less than 1.3V; therefore, the output of the zero-voltage switch is inhibited, as described above. The resistor divider R_1 and R_2 should be selected to assure this condition. When the triac is on, the voltage at point A is approximately one third of the instantaneous on state voltage (V_T) of the thyristor. For most thyristors, V_T (max) is less than 2V, and the divider shown is a conservative one. When the load current passes through zero, the triac commutates and turns off. Because the circuit is still being driven by the line voltage, the current in the load attempts to reverse, and voltage increases rapidly across the "turned-off" triac. When this voltage exceeds 4V, one portion of the CA3086 conducts and removes the inhibit signal to permit application of gate drive. Turning the triac on causes the voltage across it to drop and thus ends the gate pulse. If the latching current has not been attained, another gate pulse forms, but no discontinuity in the load current occurs.

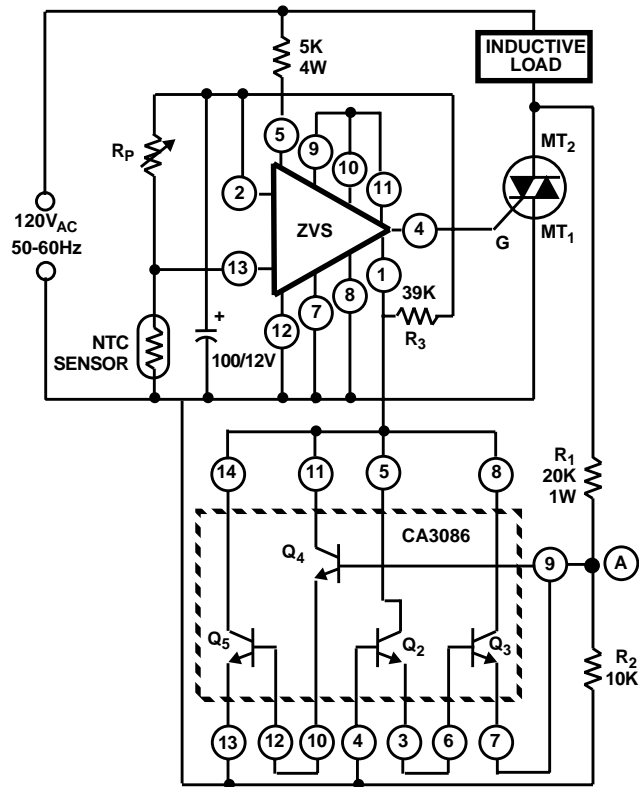
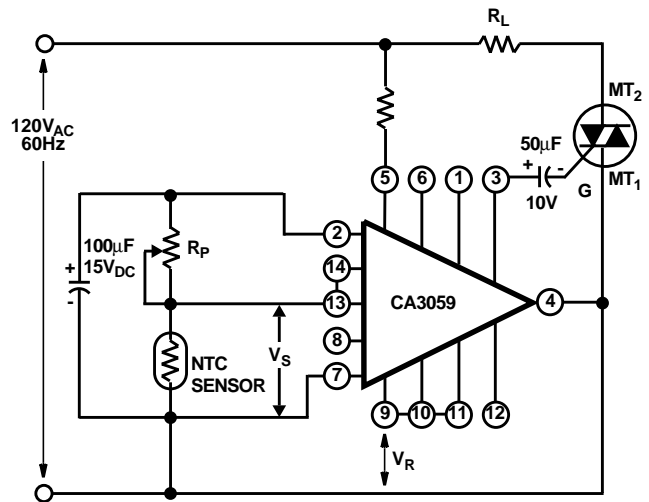

FIGURE 19. USE OF THE CA3059 TOGETHER WITH 3086 FOR SWITCHING INDUCTIVE LOADS



Provision of Negative Gate Current

Triacs trigger with optimum sensitivity when the polarity of the gate voltage and the voltage at the main terminal 2 are similar (I+ and II- modes). Sensitivity is degraded when the polarities are opposite (I- and III+ modes). Although Intersil triacs are designed and specified to have the same sensitivity in both I- and III+ modes, some other types have very poor sensitivity in the III+ condition. Because the zero-voltage switch supplies positive gate pulses, it may not directly drive some high current triacs of these other types.

The circuit shown in Figure 20A. uses the negative going voltage at terminal 3 of the zero-voltage switch to supply a negative gate pulse through a capacitor. The curve in Figure 20B. shows the approximate peak gate current as a function of gate voltage V_G . Pulse width is approximately 80µs.

FIGURE 20A.

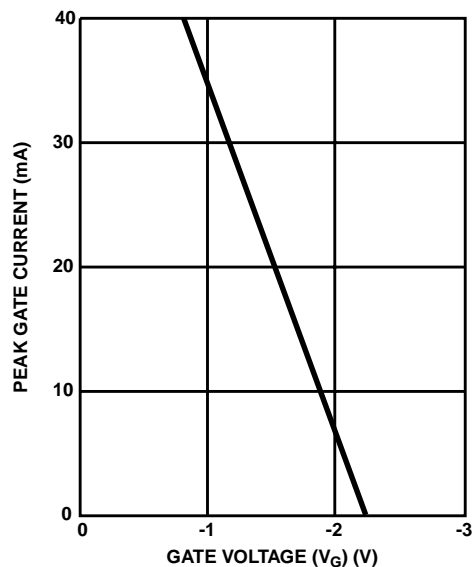

FIGURE 20B.

FIGURE 20. USE OF THE CA3059 TO PROVIDE NEGATIVE

GATE PULSES: A. SCHEMATIC DIAGRAM; B. PEAK GATE CURRENT (FAT TERMINAL 3) AS A FUNCTION OF GATE VOLTAGE

Operation with Low Impedance Sensors

Although the zero-voltage switch can operate satisfactorily with a wide range of sensors, sensitivity is reduced when sensors with impedances greater than $20,000\Omega$ are used. Typical sensitivity is one percent for a 5000Ω sensor and increases to three percent for a $0.1M\Omega$ sensor.

Low impedance sensors present a different problem. The sensor bridge is connected across the internal power supply and causes a current drain. A 5000Ω sensor with its associated 5000Ω series resistor draws less than 1mA. On the other hand, a 300Ω sensor draws a current of 8 to 10mA from the power supply.

Figure 21 shows the 600Ω load line of a 300Ω sensor on a redrawn power supply regulation curve for the zero-voltage switch. When a $10,000\Omega$ series resistor is used, the voltage across the circuit is less than 3V and both sensitivity and output current are significantly reduced. When a 5000Ω series resistor is used, the supply voltage is nearly 5V, and operation is approximately normal. For more consistent operation, however, a 4000Ω series resistor is recommended.

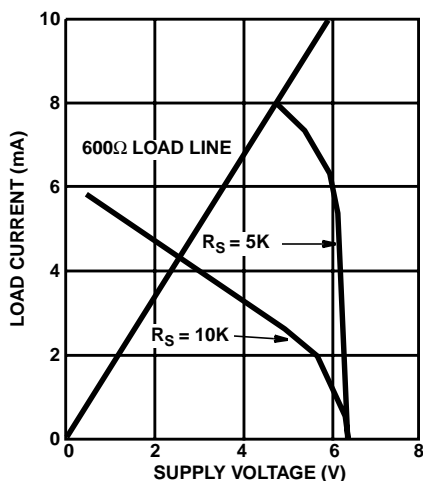
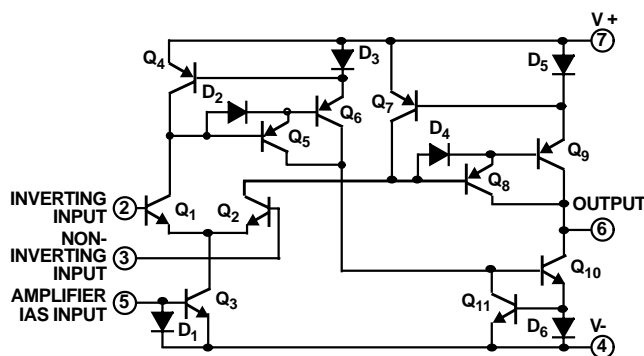

FIGURE 21. POWER SUPPLY REGULATION OF THE CA3059 WITH A 300Ω SENSOR (600Ω LOAD) FOR TWO VALUES OF SERIES RESISTOR.

Although positive temperature coefficient (PTC) sensors rated at $5k\Omega$ are available, the existing sensors in ovens are usually of a much lower value. The circuit shown in Figure 22 is offered to accommodate these inexpensive metal wound sensors. A schematic diagram of the CA3080 integrated circuit operation transconductance amplifier used in Figure 22, is shown in Figure 23. With an amplifier bias current, I_{ABC} , of $100\mu A$, a forward transconductance of $2m\Omega$ is achieved in this configuration. The CA3080 switches when the voltage at terminal 2 exceeds the voltage at terminal 3. This action allows the sink current, I_S , to flow from terminal 13 of the zero-voltage switch (the input impedance to terminal 13 of the zero-voltage switch is approximately $50k\Omega$); gate pulses are no longer applied to the triac because Q_2 of the zero-voltage switch is on. Hence, if the PTC sensor is cold, i.e., in the low resistance state, the load is energized. When the temperature of the PTC sensor increases to the desired temperature, the sensor enters the high resistance state, the voltage on



terminal 2 becomes greater than that on terminal 3, and the triac switches the load off.

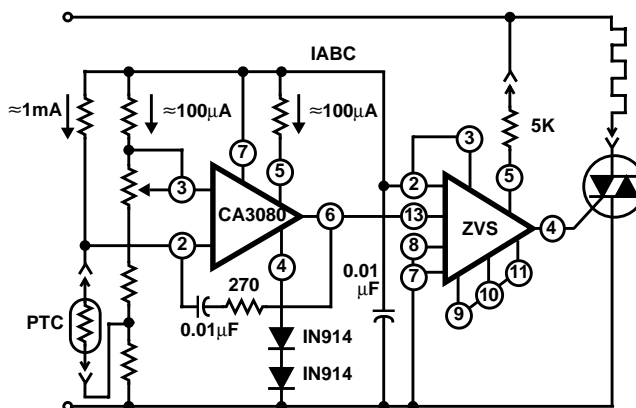

FIGURE 22. SCHEMATIC DIAGRAM OF CIRCUIT FOR USE WITH LOW RESISTANCE SENSOR

FIGURE 23. SCHEMATIC DIAGRAM OF THE CA3080

Further cycling depends on the voltage across the sensor. Hence, very low values of sensor and potentiometer resistance can be used in conjunction with the zero-voltage switch power supply without causing adverse loading effects and impairing system performance.

Interfacing Techniques

Figure 24 shows a system diagram that illustrates the role of the zero-voltage switch and thyristor as an interface between the logic circuitry and the load. There are several basic interfacing techniques. Figure 25A. shows the direct input technique. When the logic output transistor is switched from the on state (saturated) to the off state, the load will be turned on at the next zero-voltage crossing by means of the interfacing zero-voltage switch and the triac. When the logic output transistor is switched back to the on state, zero crossing pulses from the zero-voltage switch to the triac gate will immediately cease. Therefore, the load will be turned off when the triac commutates off as the sine wave load current goes through zero. In this manner, both the turn-on and turn-off conditions

Application Note 6182

for the load are controlled.

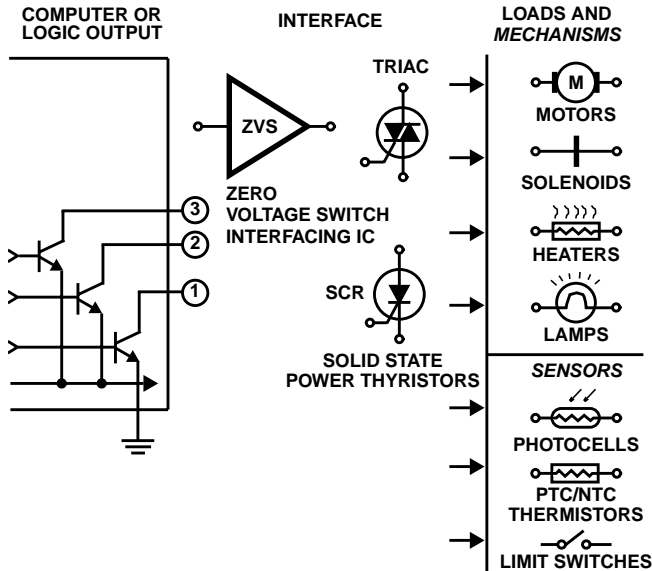

FIGURE 24. THE ZERO-VOLTAGE SWITCH AND THYRISTOR AS AN INTERFACE

When electrical isolation between the logic circuit and the load is necessary, the **isolated-input** technique shown in Figure 25B. is used. In the technique shown, optical coupling is used to achieve the necessary isolation. The logic output transistor switches the light source portion of the isolator. The light sensor portion changes when the logic output transistor is switched from off to on. The light sensor is connected to the differential amplifier input of the zero-voltage switch, which senses the change of impedance at

a threshold level and switches the load on as in Figure 25A.

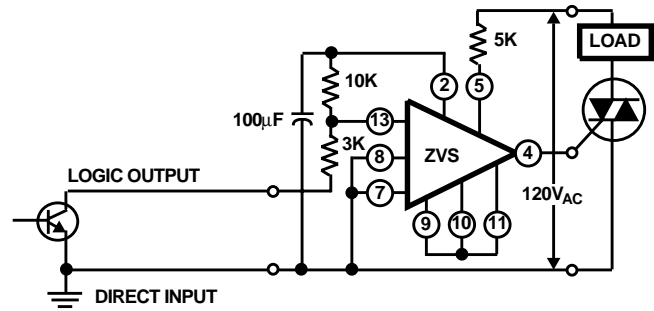

FIGURE 25A.

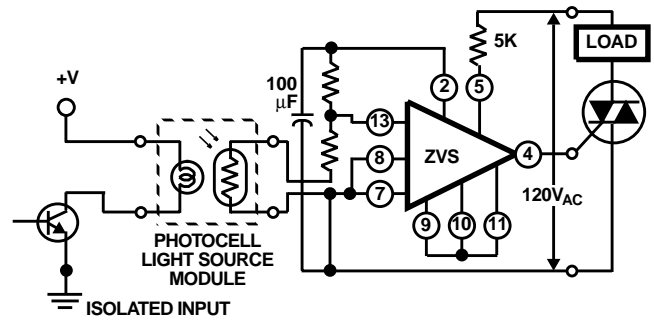

FIGURE 25B.

FIGURE 25. BASIC INTERFACING TECHNIQUES: A. DIRECT INPUT; B. ISOLATED INPUT

Sensor Isolation

In many applications, electrical isolation of the sensor from the AC input line is desirable. Several isolation techniques are shown in Figures 26, 27, and 28.

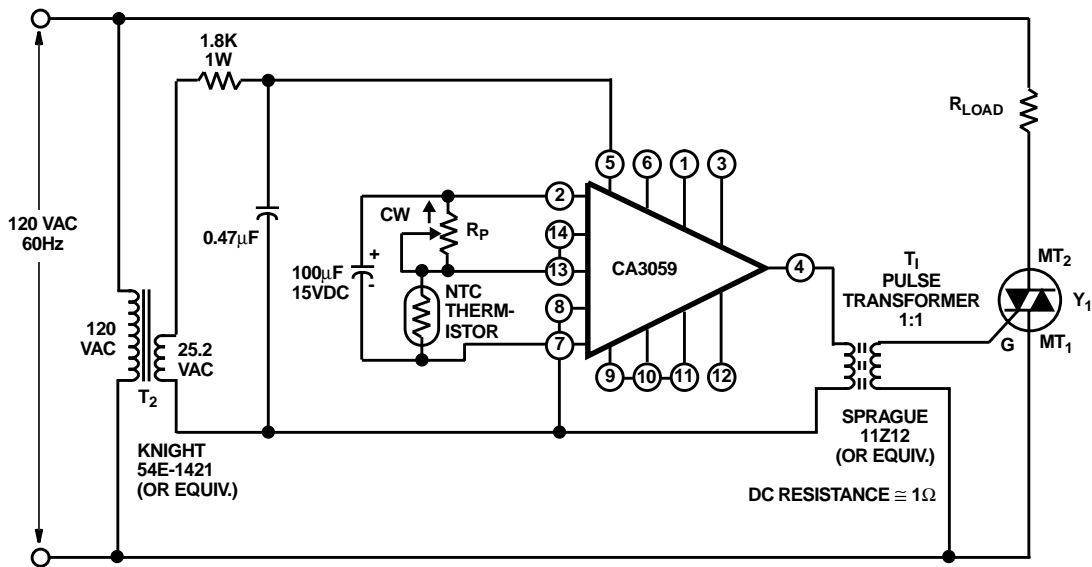

FIGURE 26. ZERO-VOLTAGE SWITCH, ON/OFF CONTROLLER WITH AN ISOLATED SENSOR

Application Note 6182

Transformer Isolation - In Figure 26, a pulse transformer is used to provide electrical isolation of the sensor from incoming AC power lines. The pulse transformer T_1 isolates the sensor from terminal No. 1 of the triac Y_1 , and transformer T_2 isolates the CA3059 from the power lines. Capacitor C_1 shifts the phase of the output pulse at terminal No. 4 in order to retard the gate pulse delivered to triac Y_1 to compensate for the small phase shift introduced by transformer T_1 .

Many applications require line isolation but not zero-voltage switching. A line isolated temperature controller for use with inductive or resistive loads that does not include zero-voltage switching is shown in Figure 27.

In temperature monitoring or control applications the sensor

may be a temperature dependent element such as a resistor, thermistor, or diode. The load may be a lamp, bell, horn, recorder or other appropriate device connected in a feedback relationship to the sensor.

For the purpose of the following explanation, assume that the sensor is a resistor having a negative temperature coefficient and that the load is a heater thermally coupled to the sensor, the object being to maintain the thermal coupling medium at a desired reference temperature. Assume initially that the temperature at the coupling medium is low.

The operating potentials applied to the bridge circuit produce a common mode potential, V_{CM} , at the input terminals of the CA3094. Assuming the bridge to have been initially bal-

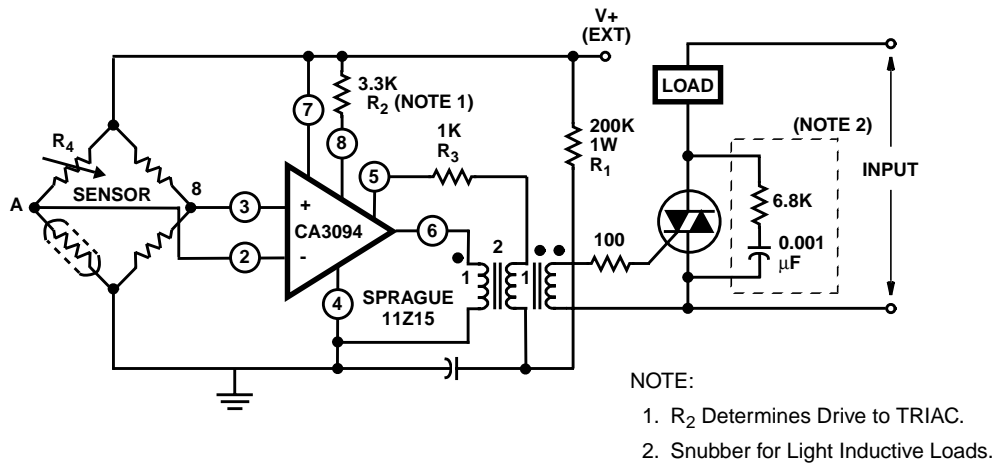
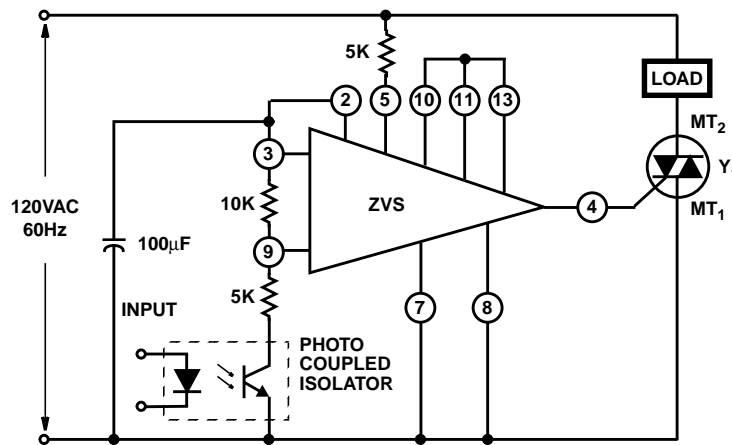

FIGURE 27. A LINE ISOLATED TEMPERATURE CONTROLLER FOR USE WITH INDUCTIVE OR RESISTIVE LOADS; THIS CONTROLLER DOES NOT INCLUDE ZERO-VOLTAGE SWITCHING.



Application Note 6182

anced (by adjustment of R_4), the potential at point A will increase when temperature is low since it was assumed that the sensor has a negative temperature coefficient. The potential at the noninverting terminal, being greater than that at the inverting terminal at the amplifier, causes the multivibrator to oscillate at approximately 10kHz. The oscillations are transformer coupled through a current limiting resistor to the gate of the thyristor, and trigger it into conduction.

When the thyristor conducts, the load receives AC input power, which tends to increase the temperature of the sensor. This temperature increase decreases the potential at point A to a value below that at point B and the multivibrator is disabled, which action, in turn, turns off the thyristor. The temperature is thus controlled in an of/off fashion.

Capacitor C_1 is used to provide a low impedance path to ground for feedback induced signals at terminal No. 5 while blocking the direct current bias provided by resistor R_1 . Resistor R_2 provides current limiting. Resistor R_3 limits the secondary current of the transformer to prevent excessive current flow to the control terminal of the CA3094.

Photocoupler Isolation - In Figure 28, a photocoupler provides electrical isolation of the sensor logic from the incoming AC power lines. When a logic "1" is applied at the input of the photocoupler, the triac controlling the load will be turned on whenever the line voltage passes through zero. When a logic "0" is applied to the photocoupler, the triac will turn off and remain off until a logic "1" appears at the input of the photocoupler.

Temperature Controllers

Figure 29 shows a triac used in an of/off temperature controller configuration. The triac is turned on at zero-voltage whenever the voltage V_S exceeds the reference voltage V_R . The transfer characteristic of this system, shown in Figure 30A., indicates significant thermal overshoots and undershoots, a well known characteristic of such a system. The differential or hysteresis of this system, however, can be further increased, if desired, by the addition of positive feedback.

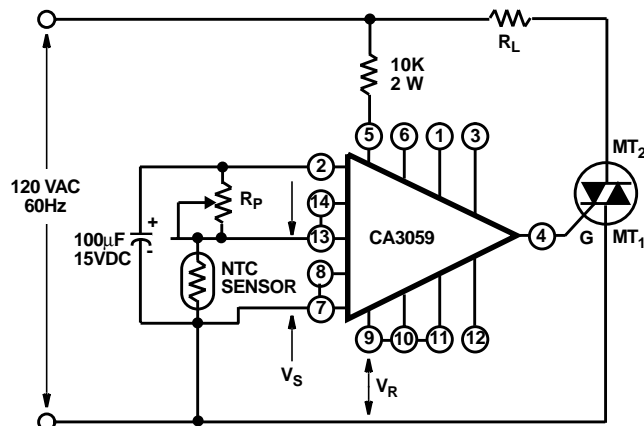

FIGURE 29. CA3059 ON/OFF TEMP. CONTROLLER

For precise temperature control applications, the proportional control technique with synchronous switching is employed. The transfer curve for this type of controller is shown in Figure 30B. In this case, the duty cycle of the power supplied to the load is varied with the demand for heat required and the thermal time constant (inertia) of the system. For example, when the temperature setting is increased in an of/off type of controller, full power (100 percent duty cycle) is supplied to the system. This effect results in significant temperature excursions because there is no anticipatory circuit to reduce the power gradually before the actual set temperature is achieved. However, in a proportional control technique, less power is supplied to the load (reduced duty cycle) as the error signal is reduced (sensed temperature approaches the set temperature).

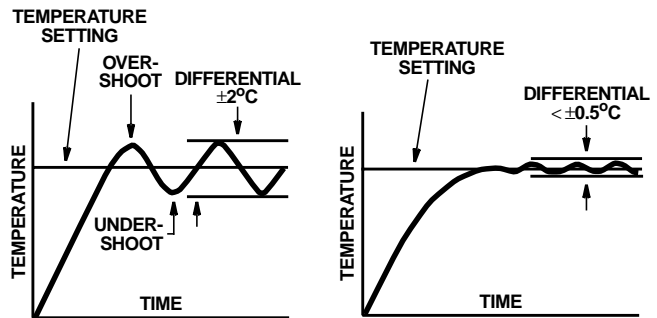

FIGURE 30A.

FIGURE 30B.

FIGURE 30. TRANSFER CHARACTERISTICS OF A. ON/OFF AND B. PROPORTIONAL CONTROL SYSTEMS

Before such a system is implemented, a time base is chosen so that the on time of the triac is varied within this time base. The ratio of the on-to-off time of the triac within this time interval depends on the thermal time constant of the system and the selected temperature setting. Figure 31 illustrates the principle of proportional control. For this operation, power is supplied to the load until the ramp voltage reaches a value greater than the DC control signal supplied to the opposite side of the differential amplifier. The triac then remains off for the remainder of the time base period. As a result, power is "proportioned" to the load in a direct relation to the heat demanded by the system.

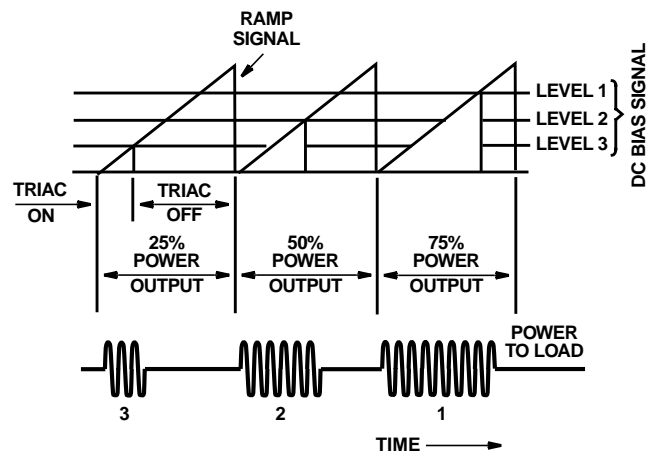

FIGURE 31. PRINCIPLES OF PROPORTIONAL CONTROL

Application Note 6182

For this application, a simple ramp generator can be realized with a minimum number of active and passive components. A ramp having good linearity is not required for proportional operation because of the nonlinearity of the thermal system and the closed loop type of control. In the circuit shown in Figure 32, the ramp voltage is generated when the capacitor C_1 charges through resistors R_0 and R_1 . The time base of the ramp is determined by resistors R_2 and R_3 , capacitor C_2 ,

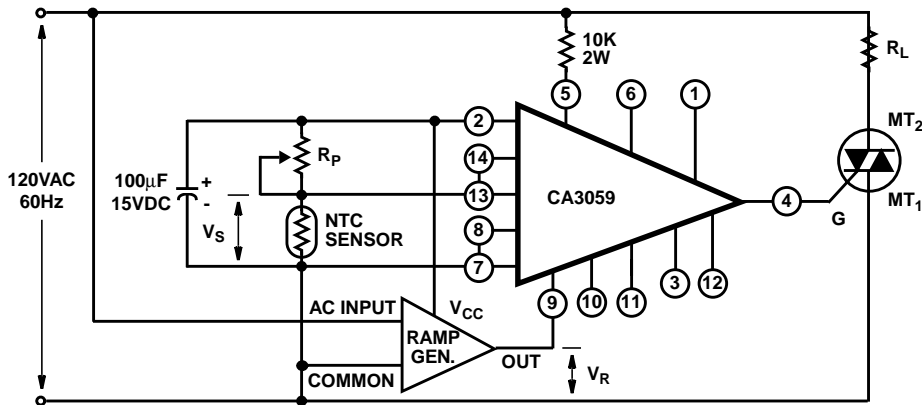
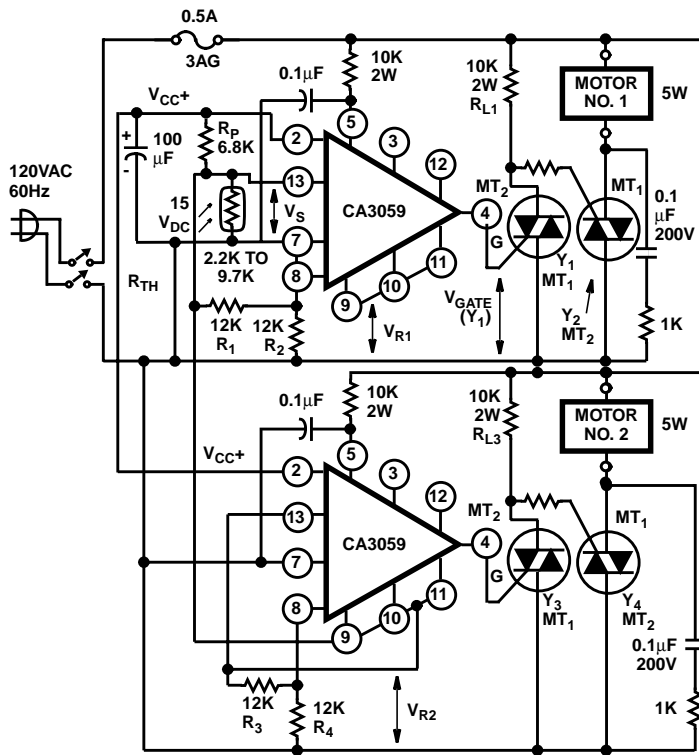
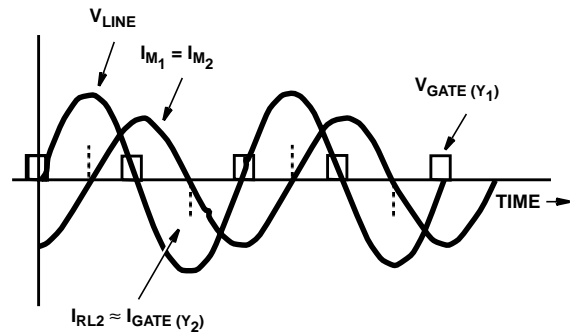

FIGURE 33. CA3059 PROPORTIONAL TEMPERATURE CONTROLLER



(a)

(b)



Application Note 6182

and the breakover voltage of the Teccor HT-32 diac.

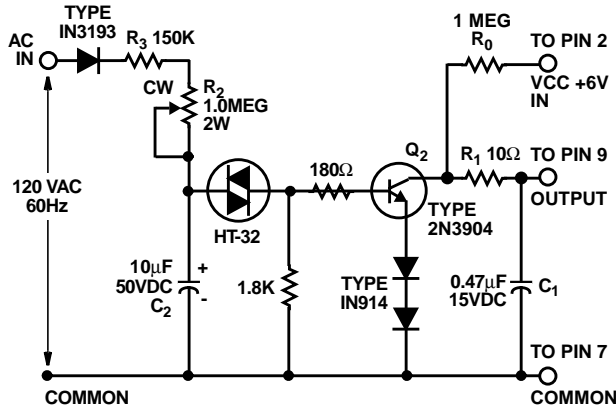

All Resistors 1/2 Watt
Unless Otherwise Specified

Pin Connections Refer to
the CA3059

FIGURE 32. RAMP GENERATOR

When the voltage across C_2 reaches approximately 32V, the diac switches and turns on the 2N3904 transistor and 1N914 diodes.

The capacitor C_1 then discharges through the collector-to-emitter junction of the transistor. This discharge time is the retrace or fly-back time of the ramp. The circuit shown can generate ramp times ranging from 0.3 to 2.0 seconds through adjustment of R_2 . For precise temperature regulation, the time base of the ramp should be shorter than the thermal time constant of the system, but long with respect to the period of the 60Hz line voltage. Figure 33 shows a triac connected for the proportional mode.

Figure 34(a) shows a dual output temperature controller that drives two triacs. When the voltage V_S developed across the temperature sensing network exceeds the reference voltage V_{R1} , motor No. 1 turns on. When the voltage across the network drops below the reference voltage V_{R2} , motor No. 2 turns on. Because the motors are inductive, the currents I_{M1} lag the incoming line voltage. The motors, however, are switched by the triacs at zero current, as shown in Figure 34(b).

The problem of driving inductive loads such as these motors by the narrow pulses generated by the zero-voltage switch is solved by use of the sensitive gate triac. The high sensitivity of this device (3mA maximum) and low latching current (approximately 9mA) permit synchronous operation of the temperature controller circuit. In Figure 34(a), it is apparent

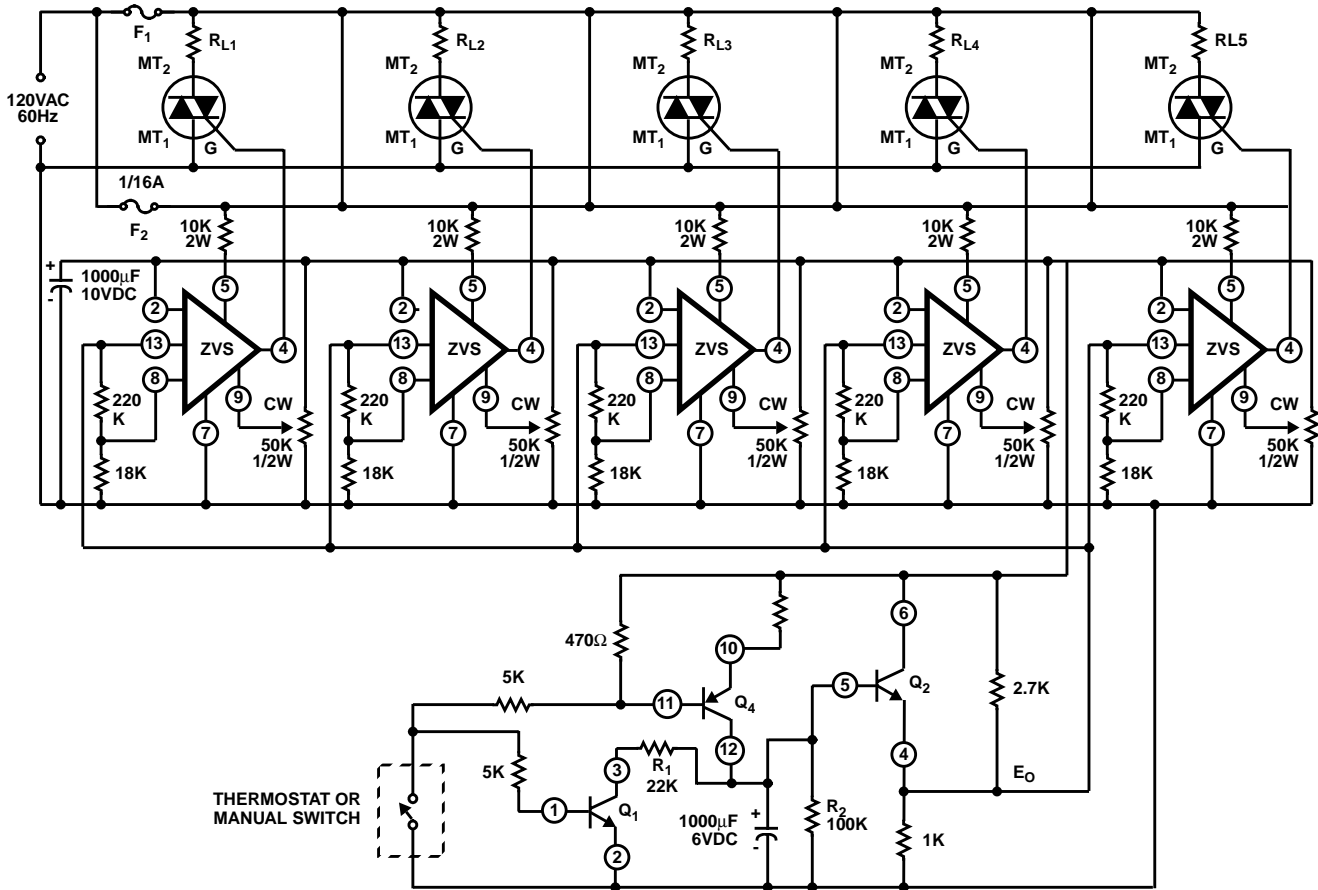

All Resistors 1/2W, Unless Otherwise Specified.
Transistors Q_1 , Q_2 and Q_4 are Part of CA3096E
Integrated Circuit N-P-N/P-N-P Transistor Array.

FIGURE 35. SYNCHRONOUS SWITCHING HEAT STAGING CONTROLLER USING A SERIES OF ZERO-VOLTAGE SWITCHES

that, though the gate pulse V_G of triac Y_1 has elapsed, triac Y_2 is switched on by the current through R_{L1} . The low latching current of the sensitive gate triac results in dissipation of only 2W in R_{L1} , as opposed to 10 to 20W when devices that have high latching currents are used.

Electric Heat Application

For electric heating applications, the 40A triac and the zero-voltage switch constitute an optimum pair. Such a combination provides synchronous switching and effectively replaces the heavy-duty contactors which easily degrade as a result of pitting and wear-out from the switching transients. The salient features of the 40A triac are as follows:

1. 300A single surge capability (for operation at 60Hz).
2. A typical gate sensitivity of 20mA in the I(+) and III(+) modes.
3. Low on state voltage of 1.5V maximum at 40A.
4. Available V_{DROM} equal to 600V.

Figure 35 shows the circuit diagram of a synchronous switching heat staging controller that is used for electric heating systems. Loads as heavy as 5kW are switched sequentially at zero-voltage to eliminate RFI and prevent a dip in line voltage that would occur if the full 25kW were to be switched simultaneously.

Transistor Q_1 and Q_4 are used as a constant current source to charge capacitor C in a linear manner. Transistor Q_2 acts as a buffer stage. When the thermostat is closed, a ramp voltage is provided at output E_O . At approximately 3 second intervals, each 5kW heating element is switched onto the power system by its respective triac. When there is no further demand for heat, the thermostat opens, and capacitor C discharges through R1 and R2 to cause each triac to turn off in the reverse heating sequence. It should be noted that some half cycling occurs before the heating element is switched fully on. This condition can be attributed to the inherent dissymmetry of the triac and is further aggravated by the slow rising ramp voltage applied to one of the inputs. The timing diagram in Figure 36 shows the turn-on and turn-off sequence of the heating system being controlled.

Seemingly, the basic method shown in Figure 35 could be modified to provide proportional control in which the number of heating elements switched into the system, under any given thermal load, would be a function of the BTU's required by the system or the temperature differential between an indoor and outdoor sensor within the total system environment. That is, the closing of the thermostat would not switch in all the heating elements within a short time interval, which inevitable results in undesired temperature excursions, but would switch in only the number of heating elements required to satisfy the actual heat load.

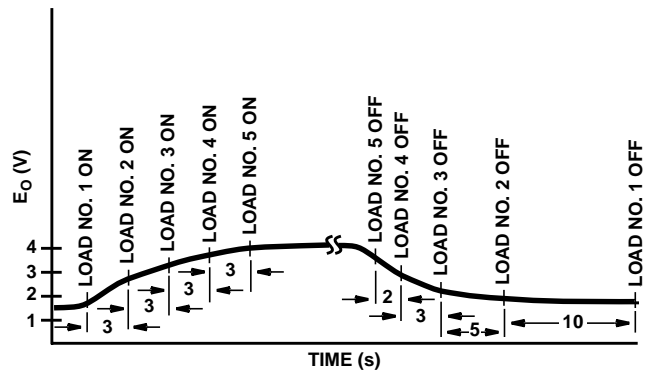

FIGURE 36. RAMP VOLTAGE WAVEFORM FOR THE HEAT STAGING CONTROLLER

Oven/Broiler Control

Zero-voltage switching is demonstrated in the oven control circuit shown in Figure 37. In this circuit, a sensor element is included in the oven to provide a closed loop system for accurate control of the oven temperature.

As shown in Figure 37, the temperature of the oven can be adjusted by means of potentiometer R_1 , which acts, together with the sensor, as a voltage divider at terminal 13. The voltage at terminal 13 is compared to the fixed bias at terminal 9 which is set by internal resistors R_4 and R_5 . When the oven is cold and the resistance of the sensor is high, transistors Q_2 and Q_4 are off, a pulse of gate current is applied to the triac, and heat is applied to the oven. Conversely, as the desired temperature is reached, the bias at terminal 13 turns the triac off. The closed loop feature then cycles the oven element on and off to maintain the desired temperature to approximately $\pm 2^\circ\text{C}$ of the set value. Also, as has been noted, external resistors between terminals 13 and 8, and 7 and 8, can be used to vary this temperature and provide hysteresis. In Figure 11, a circuit that provides approximately 10 percent hysteresis is demonstrated.

In addition to allowing the selection of a hysteresis value, the flexibility of the control circuit permits incorporation of other features. A PTC sensor is readily used by interchanging terminals 9 and 13 of the circuit shown in Figure 37 and substituting the PTC for the NTC sensor. In both cases, the sensor element is directly returned to the system ground or common, as is often desired. Terminal 9 can be connected by external resistors to provide for a variety of biasing, e.g., to match a lower resistance sensor for which the switching point voltage has been reduced to maintain the same sensor current.

To accommodate the self-cleaning feature, external switching, which enables both broiler and oven units to be paralleled, can easily be incorporated in the design. Of course, the potentiometer must be capable of a setting such that the sensor, which must be characterized for the high, self-clean temperature, can monitor and establish control of the high temperature, self-clean mode. The ease with which this self-clean mode can be added makes the overall solid state systems cost competitive with electromechanical sys-

Application Note 6182

tems of comparable capability. In addition, the system easily calibrated, and containing less costly system wiring. incorporates solid-state reliability while being neater, more

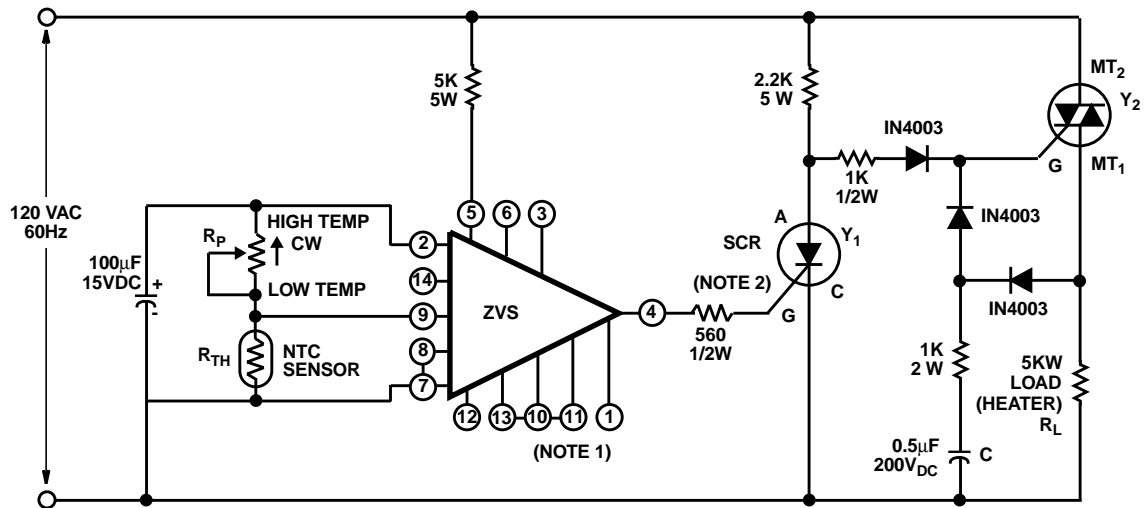

NOTE:

1. For proportional operation open terminals 10, 11 and 13, and connect positive ramp voltage to terminal 13.
2. SCR selected for $I_{GT} = 6\text{mA}$ maximum.

FIGURE 38. INTEGRAL CYCLE TEMPERATURE CONTROLLER IN WHICH HALF CYCLING EFFECT IS ELIMINATED

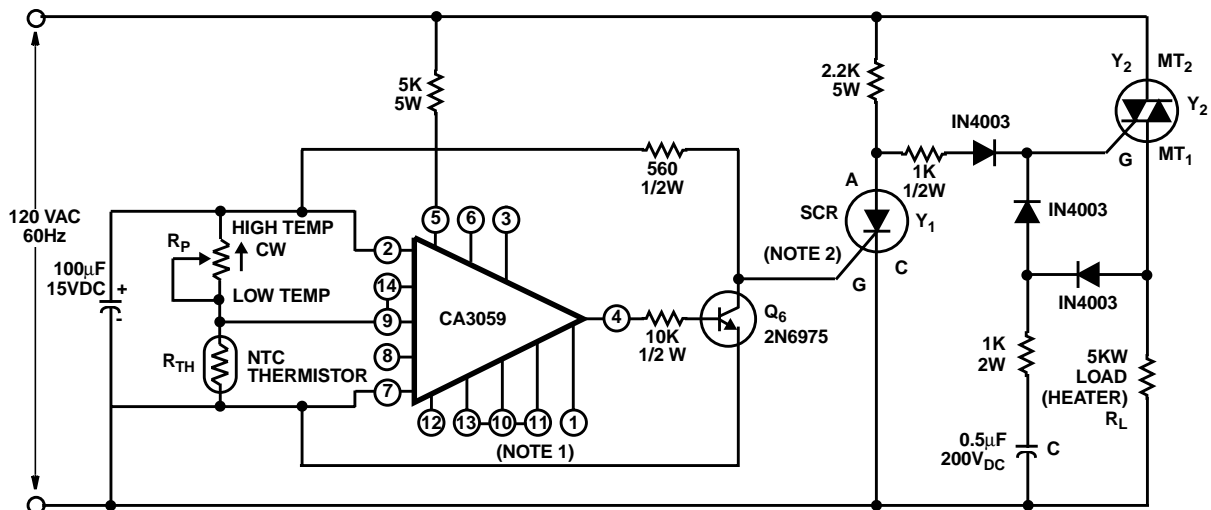

NOTE:

1. For proportional operation open terminals 9, 10 and 11, and connect positive ramp voltage to terminal 9.
2. SCR selected for $I_{GT} = 6\text{mA}$ maximum.

FIGURE 39. CA3059 INTEGRAL CYCLE TEMPERATURE CONTROLLER THAT FEATURES A PROTECTION CIRCUIT AND NO HALF CYCLING EFFECT

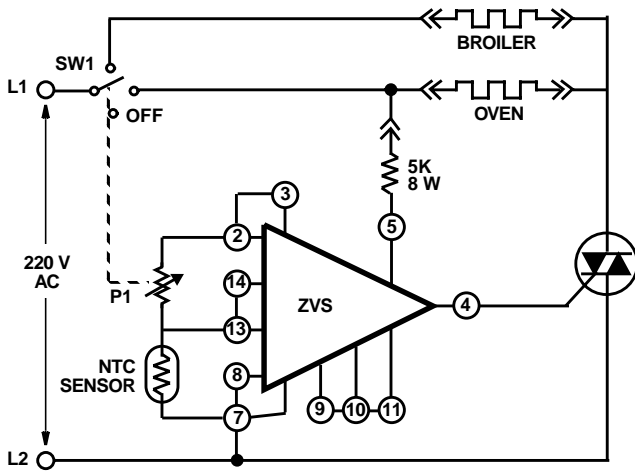

FIGURE 37. SCHEMATIC DIAGRAM OF BASIC OVEN CONTROL
Integral Cycle Temperature Controller (No half cycling)

If a temperature controller which is completely devoid of half cycling and hysteresis is required, then the circuit shown in Figure 38 may be used. This type of circuit is essential for applications in which half cycling and the resultant DC component could cause overheating of a power transformer on the utility lines.

In the integral cycle controller, when the temperature being controlled is low, the resistance of the thermistor is high, and an output signal at terminal 4 of zero volts is obtained. The SCR (Y_1), therefore, is turned off. The triac (Y_2) is then triggered directly from the line on positive cycles of the AC voltage. When Y_2 is triggered and supplies power to the load R_L , capacitor C is charged to the peak of the input voltage. When the AC line swings negative, capacitor C discharges through the triac gate to trigger the triac on the negative half cycle. The diode-resistor-capacitor "slaving network" triggers the triac on negative half cycle to provide only integral cycles of AC power to the load.

When the temperature being controlled reaches the desired value, as determined by the thermistor, then a positive voltage level appears at terminal 4 of the zero-voltage switch. The SCR then starts to conduct at the beginning of the positive input cycle to shunt the trigger current away from the gate of the triac. The triac is then turned off. The cycle repeats when the SCR is again turned OFF by the zero-voltage switch.

The circuit shown in Figure 39 is similar to the configuration in Figure 38 except that the protection circuit incorporated in the zero-voltage switch can be used. In this new circuit, the NTC sensor is connected between terminals 7 and 13, and transistor Q_0 inverts the signal output at terminal 4 to nullify the phase reversal introduced by the SCR (Y_1). The internal power supply of the zero-voltage switch supplies bias current to transistor Q_0 .

Of course, the circuit shown in Figure 39 can readily be converted to a **true proportional integral cycle temperature**

controller simply by connection of a positive going ramp voltage to terminal 9 (with terminals 10 and 11 open), as previously discussed in this Note.

Thermocouple Temperature Control

Figure 40 shows the CA3080A operating as a preamplifier for the zero-voltage switch to form a zero-voltage switching circuit for use with thermocouple sensors.

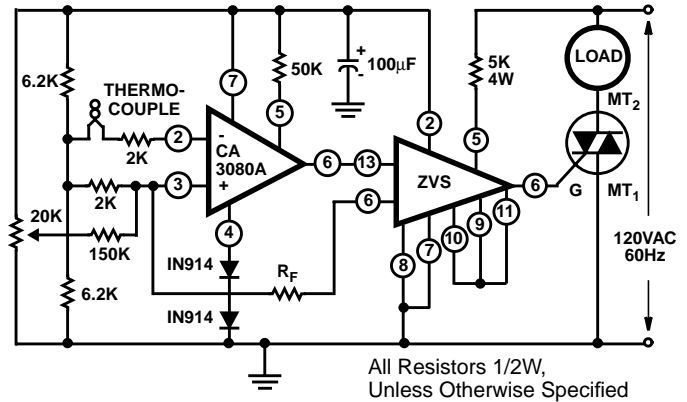
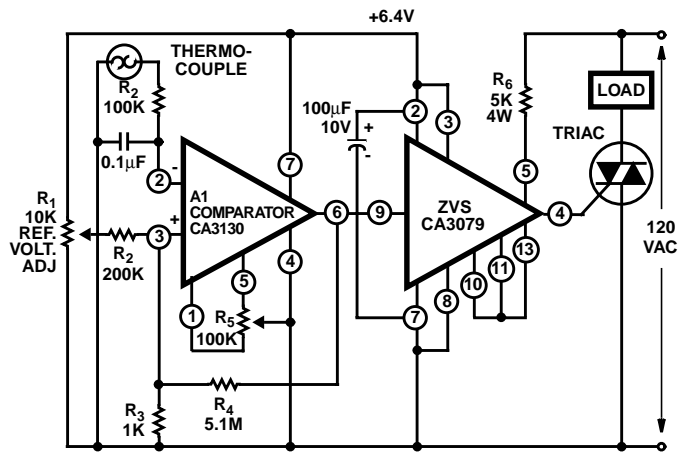

FIGURE 40. THERMOCOUPLE TEMPERATURE CONTROL
WITH ZERO-VOLTAGE SWITCHING

Thermocouple Temperature Control with Zero-Voltage Load Switching

Figure 41 shows the circuit diagram of a thermocouple temperature control system using zero-voltage load switching. It should be noted that one terminal of the thermocouple is connect to one leg of the supply line. Consequently, the thermocouple can be "ground referenced", provided the appropriate leg of the AC line is maintained at ground. The comparator, A_1 (a CA3130), is powered from a 6.4V source of potential provided by the zero-voltage switch (ZVS) circuit (a CA3079). The ZVS, in turn, is powered off-line through a series dropping resistor R_6 . Terminal 4 of the ZVS provides trigger pulses to the gate of the load switching triac in response to an appropriate control signal at terminal 9.



$$\text{Hysteresis} = R_3/R_4 \times 6.4V = 1K/5.1M \times 6.4V = 1.25mV$$

FIGURE 41. THERMOCOUPLE TEMPERATURE CONTROL
WITH ZERO-VOLTAGE SWITCHING

The CA3130 is an ideal choice for the type of comparator circuit shown in Figure 41 because it can "compare" low voltages (such as those generated by a thermocouple) in the proximity of the negative supply rail. Adjustment of potentiometer R_1 drives the voltage divider network R_3, R_4 so that reference voltages over the range of 0 to 20mV can be applied to noninverting terminal 3 of the comparator. Whenever the voltage developed by the thermocouple at terminal 2 is more positive than the reference voltage applied at terminal 3, the comparator output is toggled so as to sink current from terminal 9 of the ZVS; gate pulses are then no longer applied to the triac. As shown in Figure 41, the circuit is provided with a control point "hysteresis" of 1.25mV.

Nulling of the comparator is performed by means of the following procedure: Set R_1 at the low end of its range and short the thermocouple output signal appropriately. If the triac is in the conductive mode under these conditions, adjust nulling potentiometer R_5 to the point at which triac conduction is interrupted. On the other hand, if the triac is in the nonconductive mode under the conditions above, adjust R_5 to the point at which triac conduction commences. The thermocouple output signal should then be unshorted, and R_1 can be set to the voltage threshold desired for control circuit operation.

Machine Control and Automation

The earlier section on interfacing techniques indicated several techniques of controlling AC loads through a logic system. Many types of automatic equipment are not complex enough or large enough to justify the cost of a flexible logic system. A special circuit, designed only to meet the control requirements of a particular machine, may prove more economical. For example, consider the simple machine shown in Figure 42; for each revolution of the motor, the belt is advanced a prescribed distance, and the strip is then punched. The machine also has variable speed capability.

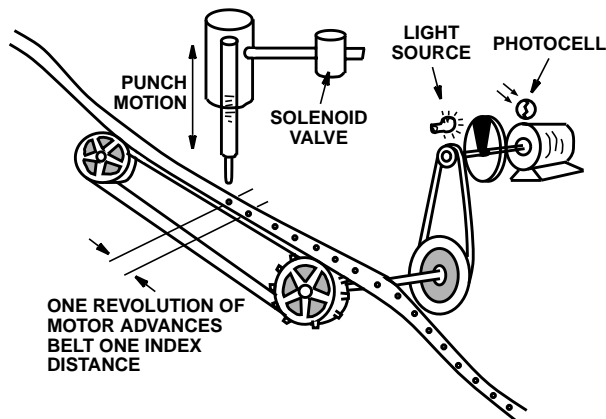
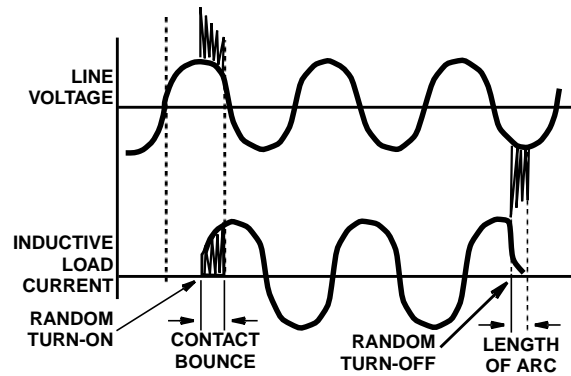

FIGURE 42. STEP-AND-PUNCH MACHINE

The typical electromechanical control circuit for such a machine might consist of a mechanical cambank driven by a separate variable speed motor, a time delay relay, and a few logic and power relays. Assuming use of industrial grade controls, the control system could get quite costly and large. Of greater importance is the necessity to eliminate transients generated each time a relay or switch energizes and deener-



gizes the solenoid and motor. Figure 43 shows such transients, which might not affect the operation of this machine, but could affect the more sensitive solid-state equipment operating in the area.

FIGURE 43. TRANSIENTS GENERATED BY RELAY CONTACT BOUNCE AND NONZERO TURN OFF OF INDUCTIVE LOAD.

A more desirable system would use triacs and zero-voltage switching to incorporate the following advantages:

1. Increased reliability and long life inherent in solid-state devices as opposed to moving parts and contacts associated with relays.
2. Minimized generation of EMI/RFI using zero-voltage switching techniques in conjunction with thyristors.
3. Elimination of high voltage transients generated by relay contact bounce and contacts breaking inductive loads, as shown in Figure 42.
4. Compactness of the control system.

The entire control system could be on one printed circuit board, and an overall cost advantage would be achieved. Figure 44 is a timing diagram for the proposed solid-state machine control, and Figure 45 is the corresponding control schematic. A variable speed machine repetition rate pulse is set up using either a unijunction oscillator or a transistor stable multivibrator in conjunction with a 10ms one shot multivibrator. The first zero voltage switch in Figure 45 is used to synchronize the entire system to zero-voltage crossing. Its output is inverted to simplify adaptation to the rest of the circuit. The center zero-voltage switch is used as an interface for the photocell, to control one revolution of the motor. The gate drive to the motor triac is continuous DC, starting at zero voltage crossing. The motor is initiated when both the machine rate pulse and the zero-voltage sync are at low voltage. The bottom zero-voltage switch acts as a time delay for pulsing the solenoid. The inhibit input, terminal 1, is used to assure that the solenoid will not be operated while the motor is running. The time delay can be adjusted by varying the reference level (50K potentiometer) at terminal 13 relative to the capacitor charging to that level on terminal 9. The capacitor is reset by the SCR during the motor operation. The gate drive to the solenoid triac is direct current. Direct current is used to trigger both the motor and solenoid triacs because it is the most desirable means of switching a triac into an inductive load. The output of the zero-voltage switch will be continuous DC by connecting terminal 12 to common. The

output under DC operation should be limited to 20mA. The motor triac is synchronized to zero crossing because it is a high current inductive load and there is a change of generating RFI. The solenoid is a very low current inductive load, so there would be little chance of generating RFI; therefore, the initial triac turn-on can be random which simplifies the circuitry.

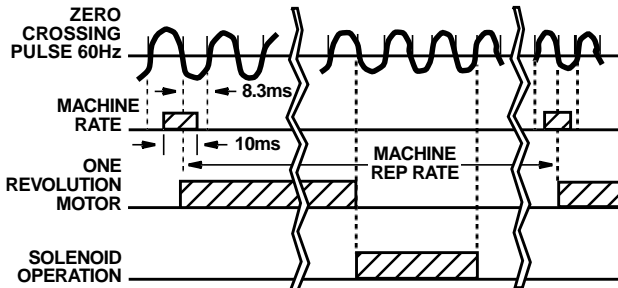

FIGURE 44. TIMING DIAGRAM FOR SOLID-STATE MACHINE CONTROL

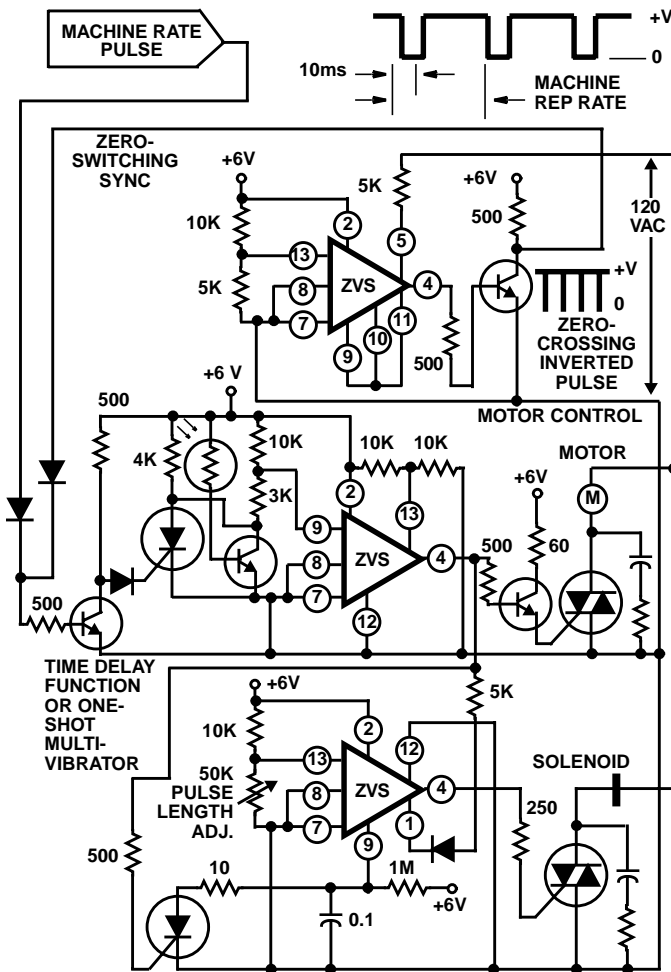

FIGURE 45. SCHEMATIC OF PROPOSED SOLID-STATE MACHINE CONTROL

This example shows the versatility and advantages of the Intersil zero-voltage switch used in conjunction with triacs as interfacing and control elements for machine control.

400Hz Triac Applications

The increased complexity of aircraft control systems, and the need for greater reliability than electromechanical switching can offer, has led to the use of solid-state power switching in aircraft. Because 400Hz power is used almost universally in aircraft systems, Intersil offers a complete line of triacs rated for 400Hz applications. Use of the Intersil zero-voltage switch in conjunction with these 400Hz triacs results in a minimum of RFI, which is especially important in aircraft.

Areas of application for 400Hz triacs in aircraft include:

1. Heater controls for food warming ovens and windshield defrosters
2. Lighting controls for instrument panels and cabin illumination
3. Motor controls and solenoid controls
4. Power supply switches

Lamp dimming is a simple triac application that demonstrates an advantage of 400Hz power over 60Hz power. Figure 46 shows the adjustment of lamp intensity by phase control of the 60Hz line voltage. RFI is generated by the step functions of power each half cycle, requiring extensive filtering. Figure 47 shows a means of controlling power to the lamp by the zero-voltage switching technique. Use of 400Hz power makes possible the elimination of complete or half cycles within a period (typically 17.5ms) without noticeable flicker. Fourteen different levels of lamp intensity can be obtained in this manner. A line synced ramp is set up with the desired period and applied to terminal No. 9 of the differential amplifier within the zero-voltage switch, as shown in Figure 48. The other side of the differential amplifier (terminal No. 13) uses a variable reference level, set by the 50K potentiometer. A change of the potentiometer setting changes the lamp intensity.

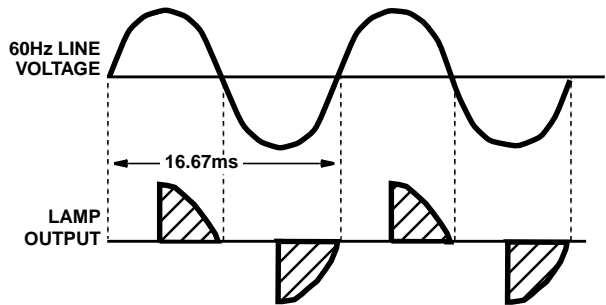

FIGURE 46. WAVEFORMS FOR 60Hz PHASE CONTROLLED LAMP DIMMER

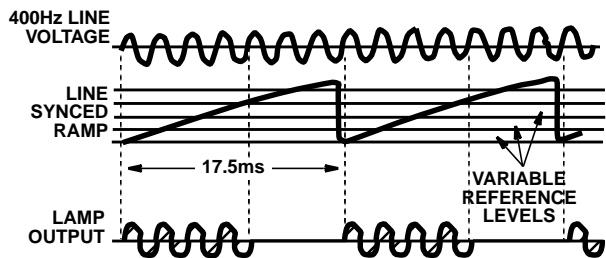

FIGURE 47. WAVEFORMS FOR 400Hz ZERO-VOLTAGE SWITCHED LAMP DIMMER

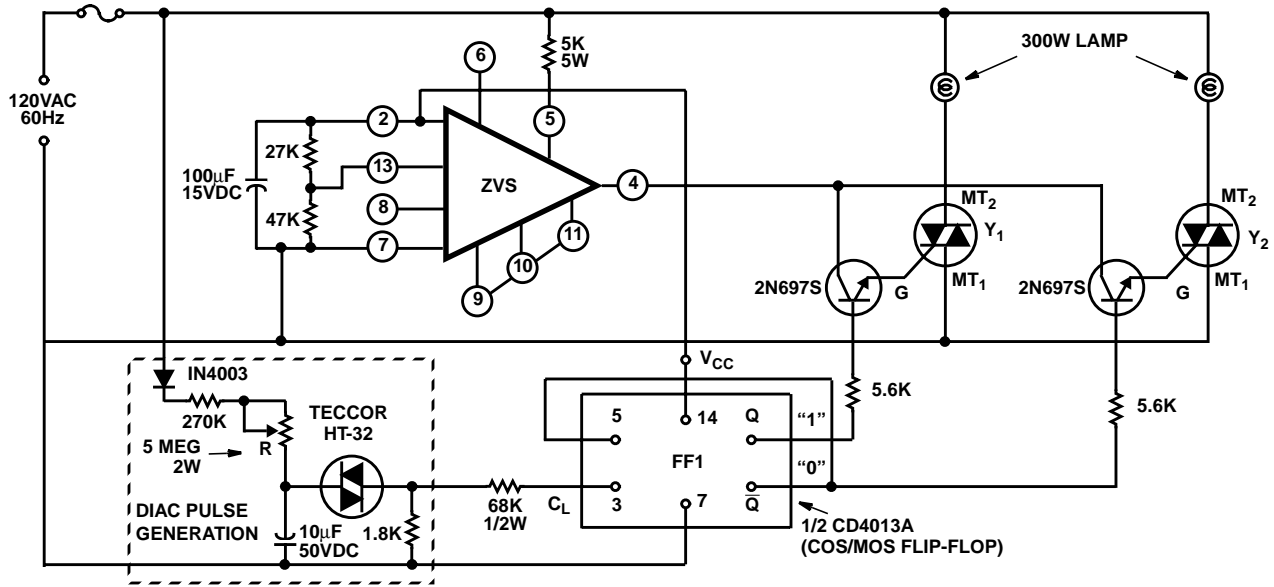

FIGURE 49. SYNCHRONOUS SWITCHING TRAFFIC FLASHER

In 400Hz applications it may be necessary to widen and shift the zero-voltage switch output pulse (which is typically 12ms wide and centered on zero-voltage crossing), to assure that sufficient latching current is available. The 4K resistor (terminal No. 12 to common) and the 0.015µF capacitor (terminal No. 5 to common) are used for this adjustment.

voltage switch, when used with Intersil thyristors, involves switching traffic control lamps. In this type of application, it is essential that a triac withstand a current surge of the lamp load on a continuous basis. This surge results from the difference between the cold and hot resistance of the tungsten filament. If it is assumed that triac turn-on is at 90 degrees from the zero-voltage crossing, the first current surge peak is approximately ten times the peak steady state rms value.

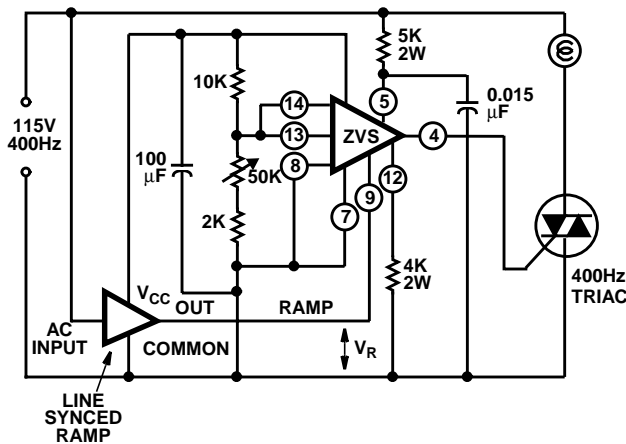

FIGURE 48. CIRCUIT DIAGRAM FOR 400Hz ZERO-VOLTAGE SWITCHED LAMP DIMMER

Solid-State Traffic Flasher

Another application which illustrates the versatility of the zero-

When the triac randomly switches the lamp, the rate of current rise di/dt is limited only by the source inductance. The triac di/dt rating may be exceeded in some power systems. In many cases, exceeding the rating results in excessive current concentrations in a small area of the device which may produce a hot spot and lead to device failure. Critical applications of this nature require adequate drive to the triac gate for fast turn on. In this case, some inductance may be required in the load circuit to reduce the initial magnitude of the load current when the triac is passing through the active region. Another method may be used which involves the switching of the triac at zero line voltage. This method involves the supply of pulses to the triac gate only during the presence of zero voltage on the AC line.

Figure 49 shows a circuit in which the lamp loads are switched at zero line voltage. This approach reduces the initial di/dt, decreases the required triac surge current ratings, increases the operating lamp life, and eliminates RFI problems. This circuit consists of two triacs, a flip-flop (FF-1), the zero-voltage switch, and a diac pulse generator. The flashing rate in this circuit is controlled by potentiometer R, which provides between 10 and 120 flashes per minute. The state of FF-1 determines the triggering of triacs Y₁ or Y₂ by the output pulses at terminal 4 generated by the zero crossing circuit. Transistors Q₁ and Q₂ inhibit these pulses to the gates of the triacs until the triacs turn

Application Note 6182

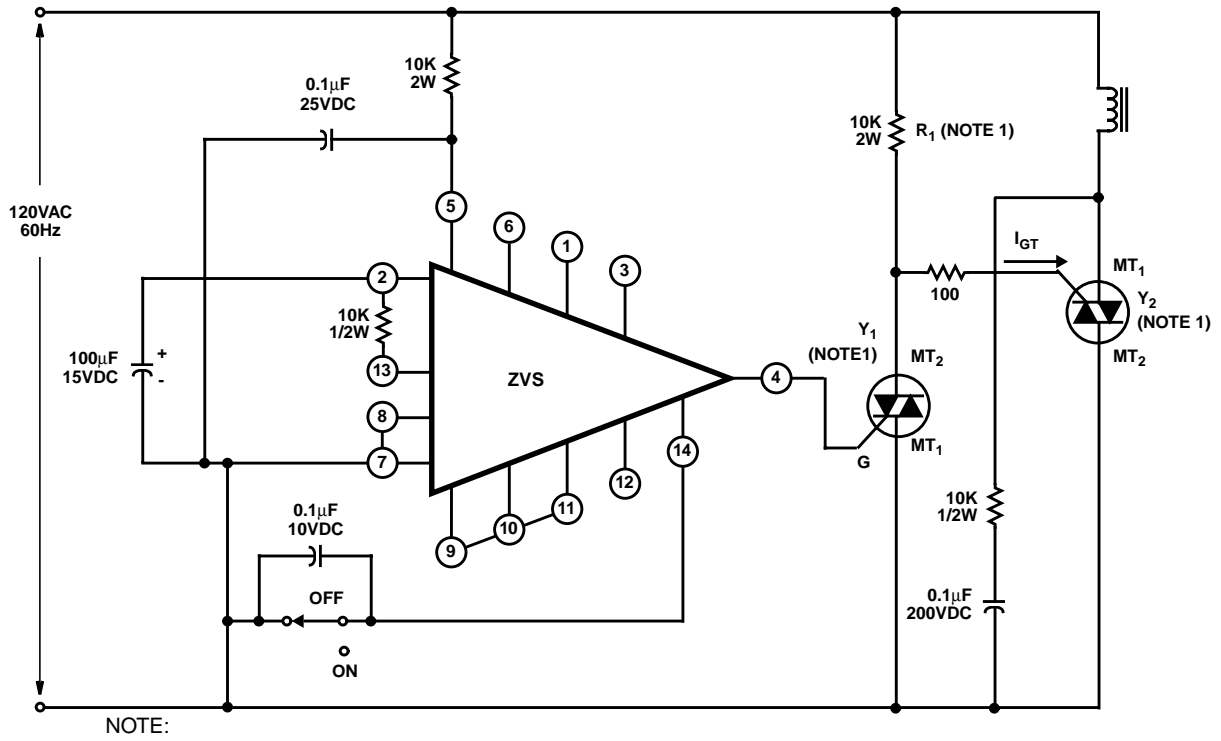

FIGURE 51. ZERO-VOLTAGE SWITCH TRANSIENT FREE SWITCH CONTROLLER IN WHICH POWER IS SUPPLIED TO THE LOAD WHEN THE SWITCH IS OPEN

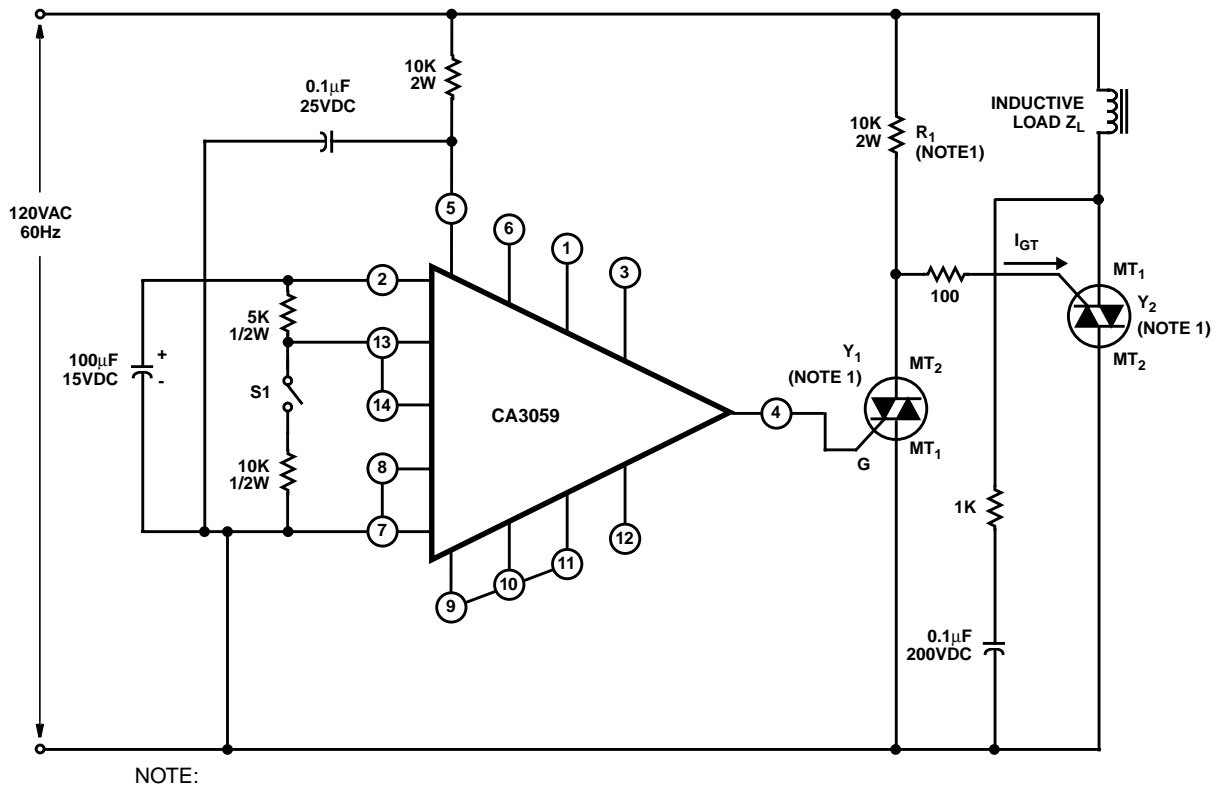

FIGURE 52. ZERO-VOLTAGE SWITCH TRANSIENT FREE SWITCH CONTROLLER IN WHICH POWER IS APPLIED TO THE LOAD

on by the logical "1" (V_{CC} high) state of the flip-flop.

The arrangement describe can also be used for a synchronous, sequential traffic controller system by addition of one triac, one gating transistor, a "divide-by-three" logic circuit, and modification in the design of the diac pulse generator. Such a system can control the familiar red, amber, and green traffic signals that are found at many intersections.

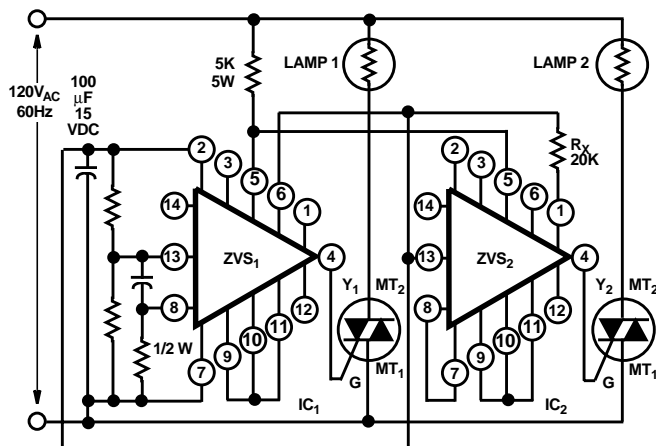

FIGURE 50. SYNCHRONOUS LIGHT FLASHER

Synchronous Light Flasher

Figure 50 shows a simplified version of the synchronous switching traffic light flasher shown in Figure 49. Flash rate is set by use of the curve shown in Figure 16. If a more precise flash rate is required, the ramp generator described previously may be used. In this circuit, ZVS_1 is the master control unit and ZVS_2 is slaved to the output of ZVS_1 through its inhibit terminal (terminal 1). When power is applied to lamp No. 1, the voltage of terminal 6 on ZVS_1 is high and ZVS_2 is inhibited by the current in R_X . When lamp No. 1 is off, ZVS_2 is not inhibited, and triac Y_2 can fire. The power supplies operate in parallel. The on/off sensing amplifier in ZVS_2 is not used.

Transient Free Switch Controllers

The zero-voltage switch can be used as a simple solid-state switching device that permits AC currents to be turned on or off with a minimum of electrical transients and circuit noise.

The circuit shown in Figure 51 is connected so that, after the control terminal 14 is opened, the electronic logic waits until the power line voltage reaches a zero crossing before power is applied to the load Z_L . Conversely, when the control terminals are shorted, the load current continues until it reaches a zero crossing. This circuit can switch a load at zero current whether it is resistive or inductive.

The circuit shown in Figure 52 is connected to provide the opposite control logic to that of the circuit shown in Figure

51. That is, when the switch is closed, power is supplied to the load, and when the switch is opened, power is removed from the load.

In both configurations, the maximum rms load current that can be switched depends on the rating of triac Y_2 .

Differential Comparator for Industrial Use

Differential comparators have found widespread use as limit detectors which compare two analog input signals and provide a go/no-go, logic "one" or logic "zero" output, depending upon the relative magnitudes of these signals. Because the signals are often at very low voltage levels and very accurate discrimination is normally required between them, differential comparators in many cases employ differential amplifiers as a basic building block. However, in many industrial control applications, a high performance differential comparator is not required. That is, high resolution, fast switching speed, and similar features are not essential. The zero-voltage switch is ideally suited for use in such applications. Connection of terminal 12 to terminal 7 inhibits the zero-voltage threshold detector of the zero-voltage switch, and the circuit becomes a differential comparator.

Figure 53 shows the circuit arrangement for use of the zero-voltage switch as a differential comparator. In this application, no external DC supply is required, as is the case with most commercially available integrated circuit comparators; of course, the output current capability of the zero-voltage switch is reduced because the circuit is operating in the DC mode. The 1000Ω resistor R_G , connected between terminal 4 and the gate of the triac,

Application Note 6182

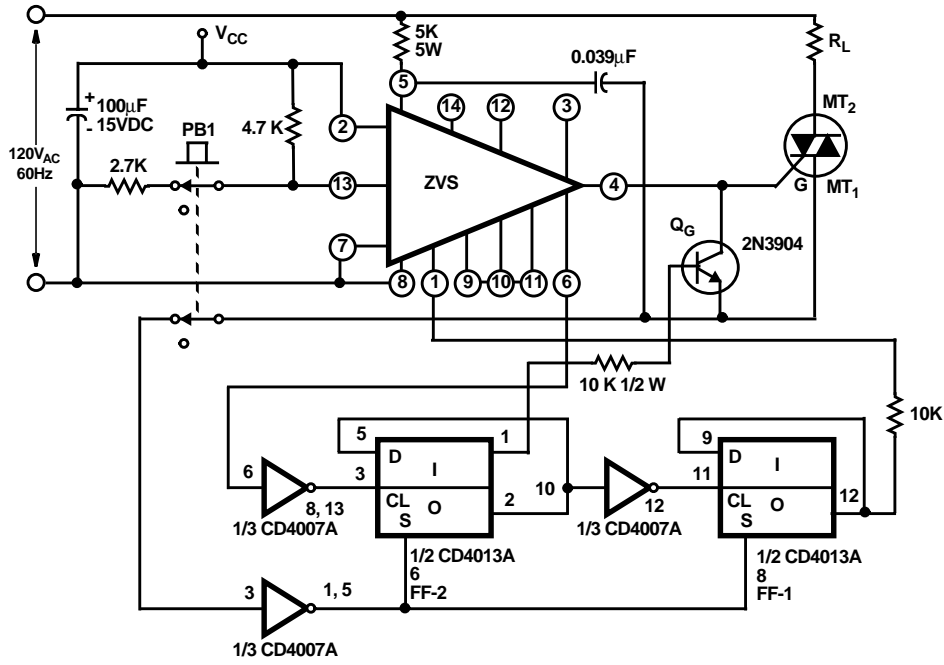
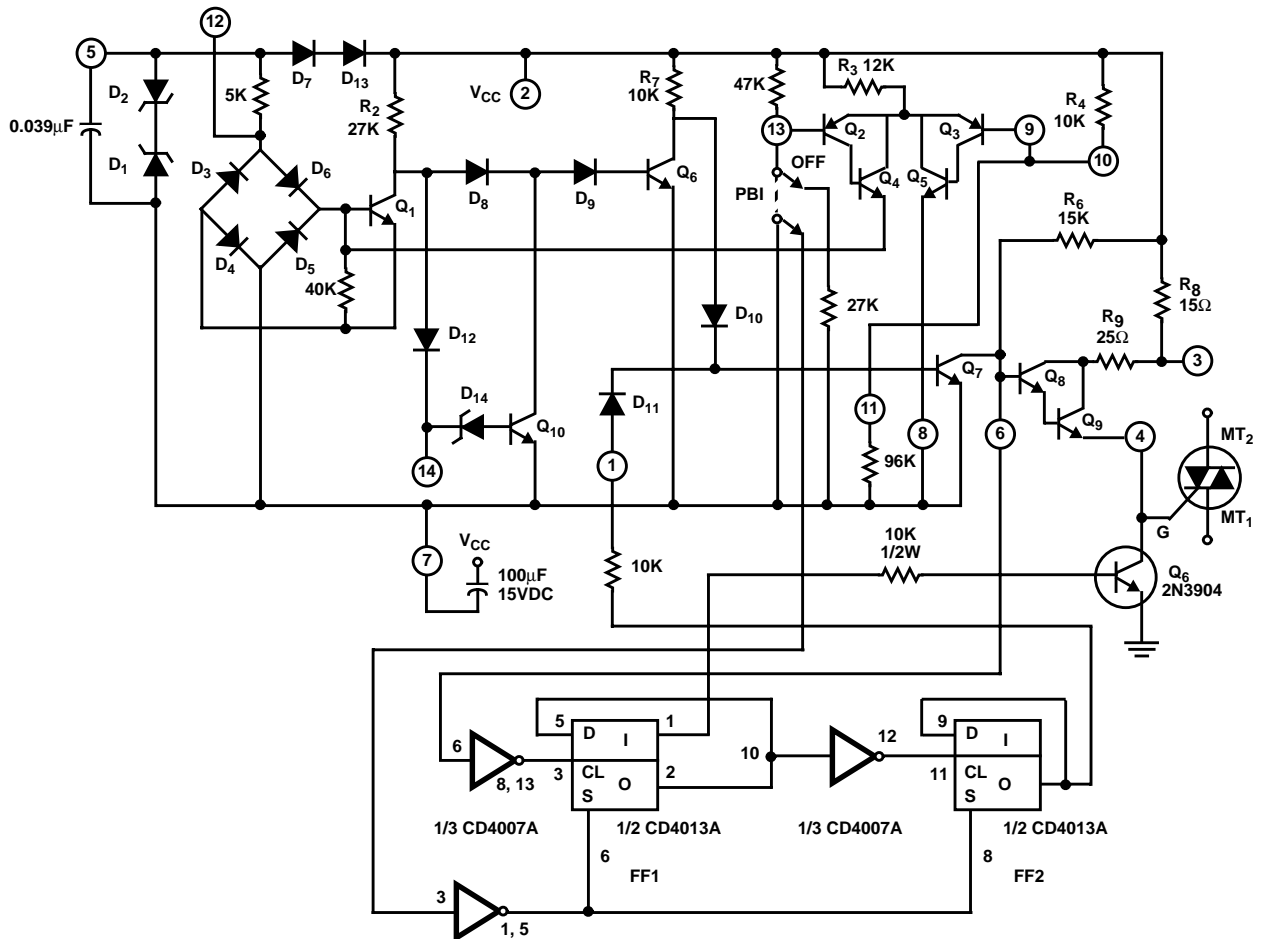

FIGURE 54. BLOCK DIAGRAM OF A POWER ONE SHOT CONTROL USING A ZERO-VOLTAGE SWITCH



Application Note 6182

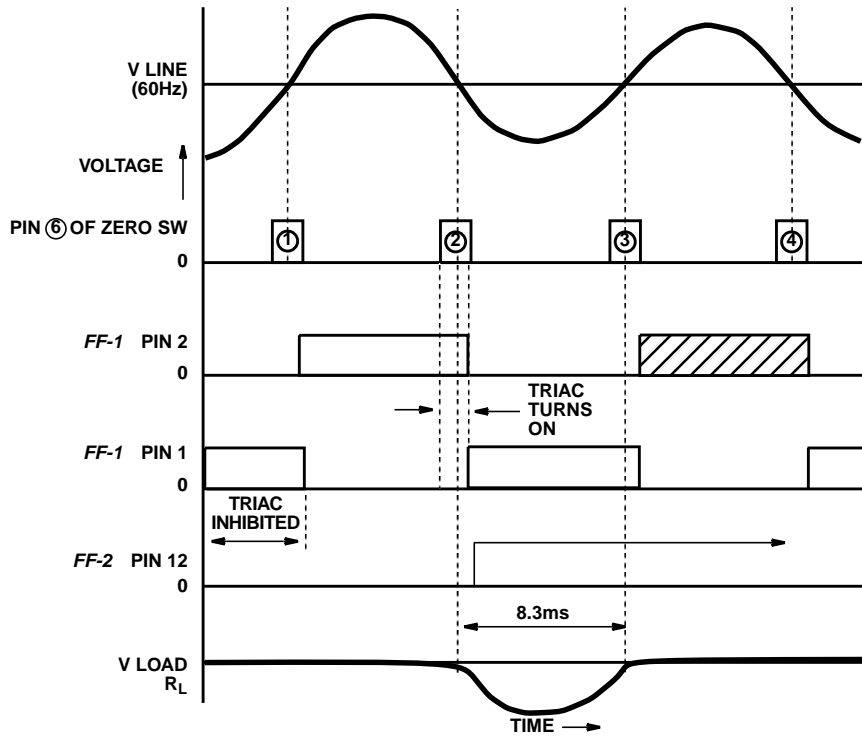
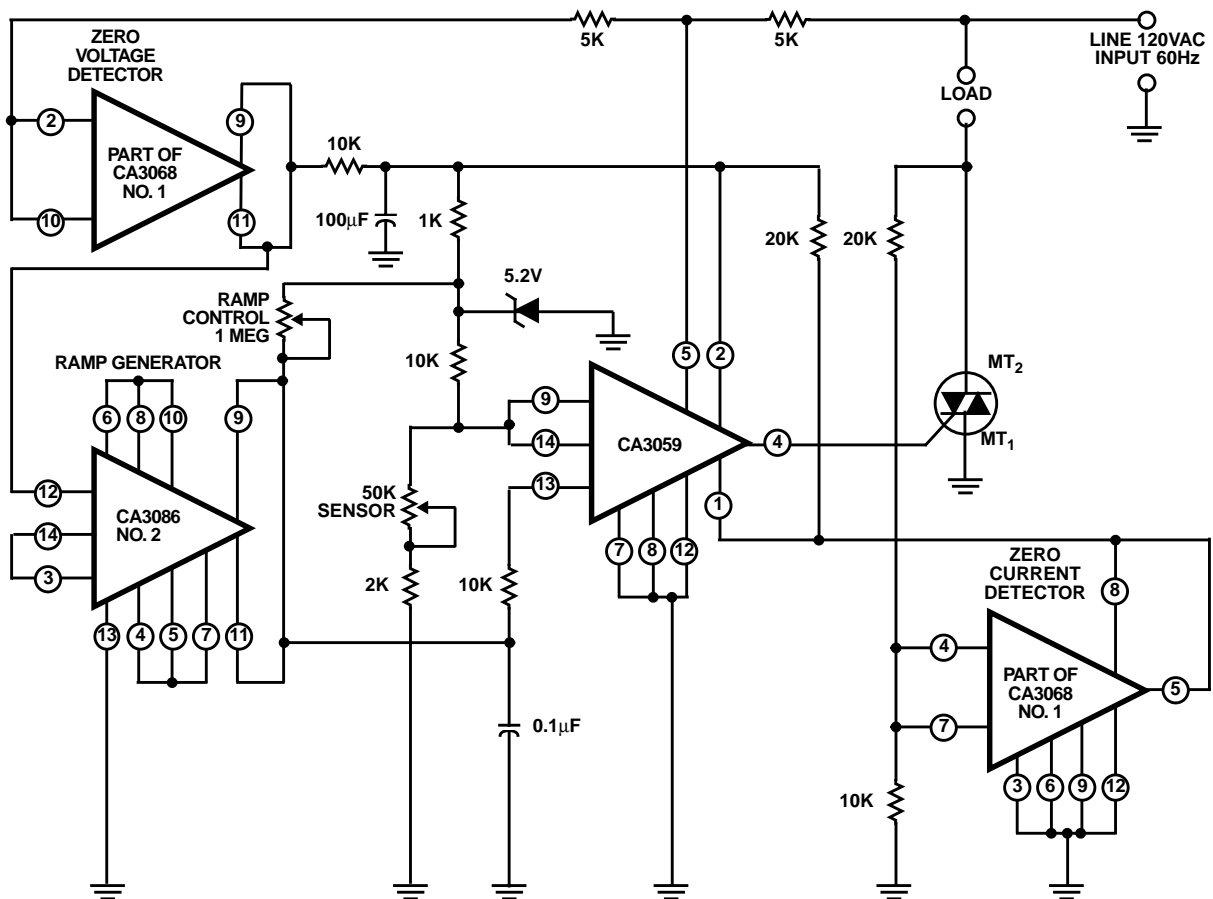

FIGURE 56. TIMING DIAGRAM FOR THE POWER ONE SHOT CONTROL



Application Note 6182

limits the output current to approximately 3mA.

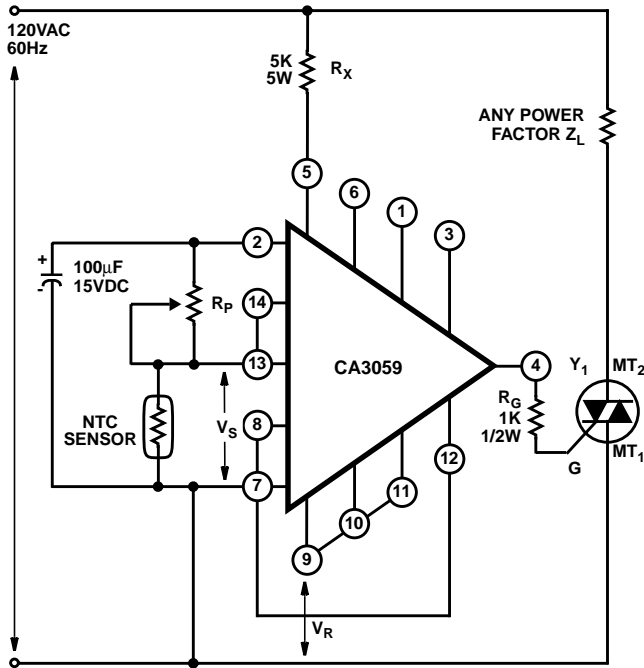

FIGURE 53. DIFFERENTIAL COMPARATOR USING THE CA3059 INTEGRATED CIRCUIT ZERO-VOLTAGE SWITCH

When the zero-voltage switch is connected in the DC mode, the drive current for terminal 4 can be determined from a curve of the external load current as a function of DC voltage from terminals 2 and 7. Of course, if additional output current is required, an external DC supply may be connected between terminals 2 and 7, and resistor R_X (shown in Figure 53) may be removed.

The chart below compares some of the operating characteristics of the zero-voltage switch, when used as a comparator, with a typical high performance commercially available integrated circuit differential comparator.

PARAMETERS	ZERO-VOLTAGE SWITCH (TYP. VALUE)	TYP. INTEGRATED CIRCUIT COMPARATOR (710)
Sensitivity	30mV	2mV
Switching Speed (Rise Time)	>20µs	90ns
Output Drive Capability	4.5V at ≤4mA (Note 1)	3.2V at ≤5.0mA

NOTE:

- Refer to Figure 20; R_X equals 5000Ω.

Power One Shot Control

Figure 54 shows a circuit which triggers a triac for one complete half cycle of either the positive or negative alternation of the AC line voltage. In this circuit, triggering is initiated by the push button PB-1, which produces triggering of the triac near zero voltage even though the button is randomly depressed during the AC cycle. The triac does not trigger again until the button is released and again depressed. This type of logic is required for the solenoid drive of electrically operated stapling guns, impulse hammers, and the like, where load current flow is required for only one complete half cycle. Such logic can also be adapted to keyboard consoles in which contact bounce produces transmission of erroneous information.

In the circuit of Figure 54, before the button is depressed, both flip-flop outputs are in the "zero" state. Transistor Q_C is biased on by the output of flip-flop FF-1. The differential comparator which is part of the zero-voltage switch is initially

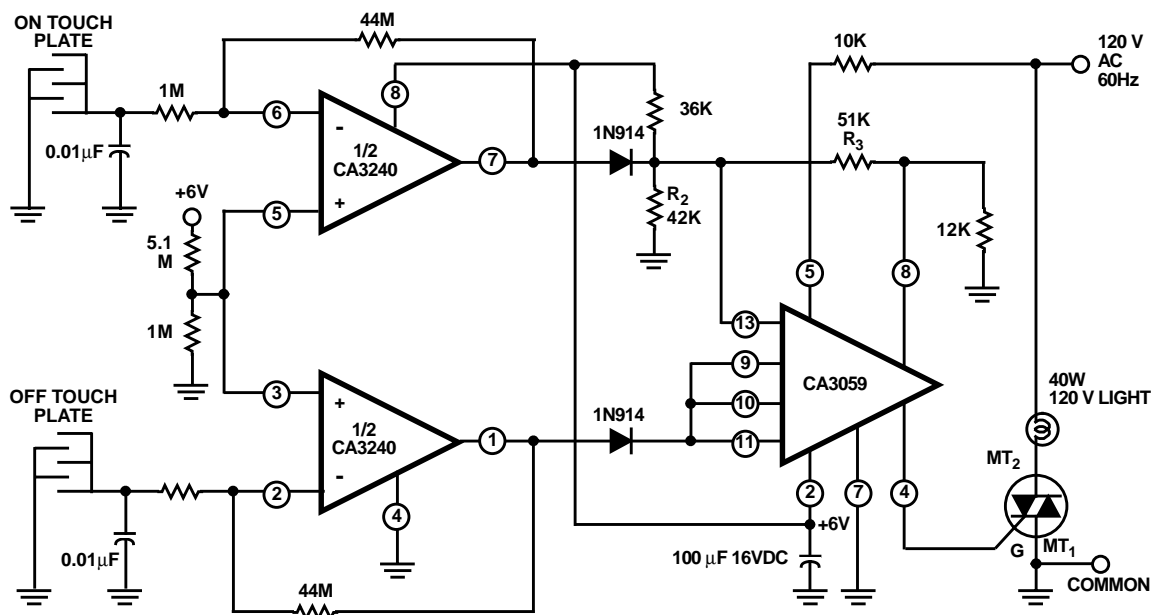

FIGURE 58. ON/OFF TOUCH SWITCH

biased to inhibit output pulses. When the push button is depressed, pulses are generated, but the state of Q_G determines the requirement for their supply to the triac gate. The first pulse generated serves as a "framing pulse" and does not trigger the triac but toggles FF-1. Transistor Q_G is then turned off. The second pulse triggers the triac and FF-1 which, in turn, toggles the second flip-flop FF-2. The output of FF-2 turns on transistor Q_7 , as shown in Figure 55, which inhibits any further output pulses. When the push-button is released, the circuit resets itself until the process is repeated with the button. Figure 56 shows the timing diagram for the described operating sequence.

Phase Control Circuit

Figure 57 shows a circuit using a CA3059 zero-voltage switch together with two CA3086 integrated circuit arrays to form a phase control circuit. This circuit is specifically designed for speed control of AC induction motors, but may also be used as a light dimmer. The circuit, which can be operated from a line frequency of 50Hz to 400Hz, consists of a zero-voltage detector, a line synchronized ramp generator, a zero current detector, and a line derived control circuit (i.e., the zero-voltage switch). The zero-voltage detector (part of CA3086 No. 1) and the ramp generator (CA3086 No. 2) provide a line synchronized ramp voltage output to terminal 13 of the zero-voltage switch. The ramp voltage, which has a starting voltage of 1.8V, starts to rise after the line voltage passes the zero point. The ramp generator has an oscillation frequency of twice the incoming line frequency. The slope of the ramp voltage can be adjusted by variation of the resistance of the 1M Ω ramp control potentiometer. The output phase can be controlled easily to provide 180 $^\circ$ firing of the triac by programming the voltage at terminal 9 of the zero-voltage switch. The basic operation of the zero-voltage switch driving a thyristor with an inductive load was

explained previously in the discussion on switching of inductive loads.

On/Off Touch Switch

The on/off touch switch shown in Figure 58 uses the CA3240E to sense small currents flowing between two contact points on a touch plate consisting of a PC board metallization "grid". When the on plate is touched, current flows between the two halves of the grid, causing a positive shift in the output voltage (terminal 7) of the CA3240E. These positive transitions are fed into the CA3059, which is used as a latching circuit and zero crossing triac driver. When a positive pulse occurs at terminal No. 7 of the CA3240E, the triac is turned on and held on by the CA3059 and associated positive feedback circuitry (51k Ω resistor and 36k Ω /42k Ω voltage divider). When the pulse occurs at terminal No. 1, the triac is turned off and held off in a similar manner. Note that power for the CA3240E is derived from the CA3059 internal power supply. The advantage of using the CA3240E in this circuit is that it can sense the small currents associated with skin conduction while maintaining sufficiently high circuit impedance to protect against electrical shock.

Triac Power Controls for Three Phase Systems

This section describes recommended configurations for power control circuits intended for use with both inductive and resistive balanced three phase loads. The specific design requirements for each type of loading condition are discussed.

In the power control circuits described, the integrated circuit zero-voltage switch is used as the trigger circuit for the power triacs. The following conditions are also imposed in the design of the triac control circuits:

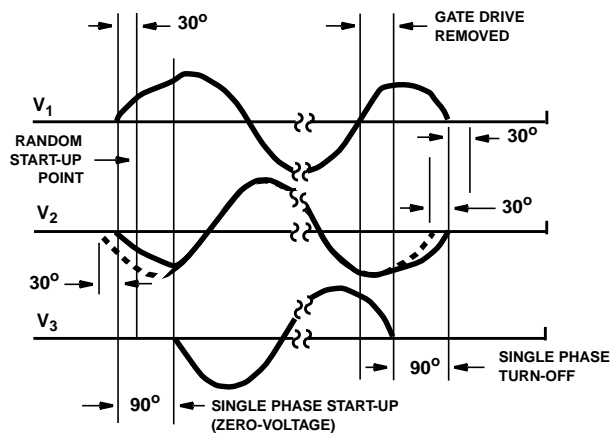

FIGURE A.

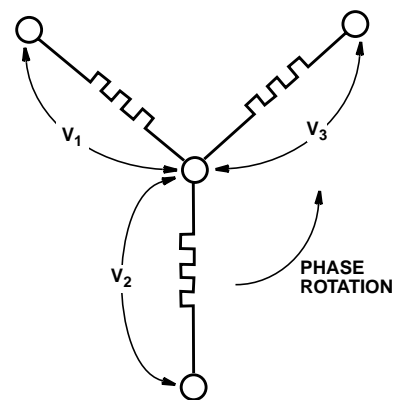

FIGURE B.

NOTE: The dashed lines indicate the normal relationship of the phases under steady state conditions. The deviation at start up and turn off should be noted.

FIGURE 59. VOLTAGE PHASE RELATIONSHIP FOR A THREE PHASE RESISTIVE LOAD WHEN THE APPLICATION OF LOAD POWER IS CONTROLLED BY ZERO-VOLTAGE SWITCHING: A. VOLTAGE WAVEFORMS, B. LOAD CIRCUIT ORIENTATION OF VOLTAGES.

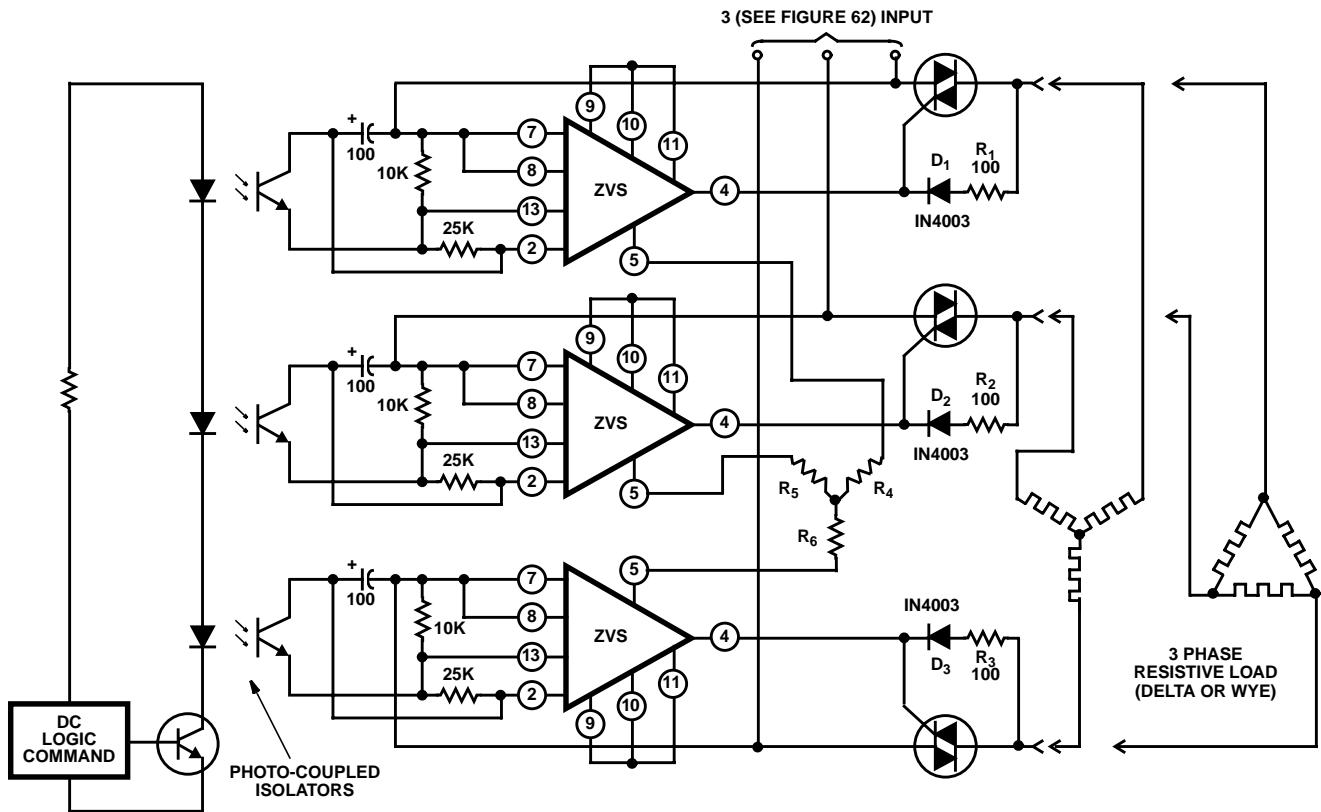

FIGURE 60. SIMPLIFIED DIAGRAM OF A THREE PHASE HEATER CONTROL THAT EMPLOYS ZERO-VOLTAGE SYNCHRONOUS SWITCHING IN THE STEADY STATE OPERATING CONDITIONS

1. The load should be connected in a three wire configuration with the triacs placed external to the load; either delta or wye arrangements may be used. Four wire loads in wye configurations can be handled as three independent single phase systems. Delta configurations in which a triac is connected within each phase rather than in the incoming lines can also be handled as three independent single phase systems.
2. Only one logic command signal is available for the control circuits. This signal must be electrically isolated from the three phase power system.
3. Three separate triac gating signals are required.
4. For operation with resistive loads, the zero-voltage switching technique should be used to minimize any radio frequency interference (RFI) that may be generated.

Isolation of DC Logic Circuitry

As explained earlier under **Special Application Considerations**, isolation of the DC logic circuitry* from the AC line, the triac, and the load circuit is often desirable even in many single phase power control applications. In control circuits for polyphase power systems, however, this type of isolation is essential, because the common point of the DC logic circuitry cannot be referenced to a common line in all phases.

* The DC logic circuitry provides the low level electrical signal that dictates the state of the load. For temperature controls, the DC logic circuitry includes a temperature sensor for feedback. The Intersil integrated circuit zero-voltage switch, when operated in the DC mode with some additional circuitry, can replace the DC logic circuitry for temperature controls.

In the three phase circuits described in this section, photo optic techniques (i.e., photo coupled isolators) are used to provide the electrical isolation of the DC logic command signal from the AC circuits and the load. The photo coupled isolators consist of an infrared light emitting diode aimed at a silicon photo transistor, coupled in a common package. The light emitting diode is the input section, and the photo transistor is the output section. The two components provide a voltage isolation typically of 1500V. Other isolation techniques, such as pulse transformers, magnetoresistors, or reed relays, can also be used with some circuit modifications.

Resistive Loads

Figure 59 illustrates the basic phase relationships of a balanced three phase resistive load, such as may be used in heater applications, in which the application of load power is controlled by zero-voltage switching. The following conditions are inherent in this type of application:

1. The phases are 120 degrees apart; consequently, all three phases cannot be switched on simultaneously at zero voltage.
2. A single phase of a wye configuration type of three wire system cannot be turned on.
3. Two phases must be turned on for initial starting of the system. These two phases form a single phase circuit which is out of phase with both of its component phases. The single phase circuit leads on phase by 30 degrees and lags the other phase by 30 degrees.

These conditions indicate that in order to maintain a system in which no appreciable RFI is generated by the switching

Application Note 6182

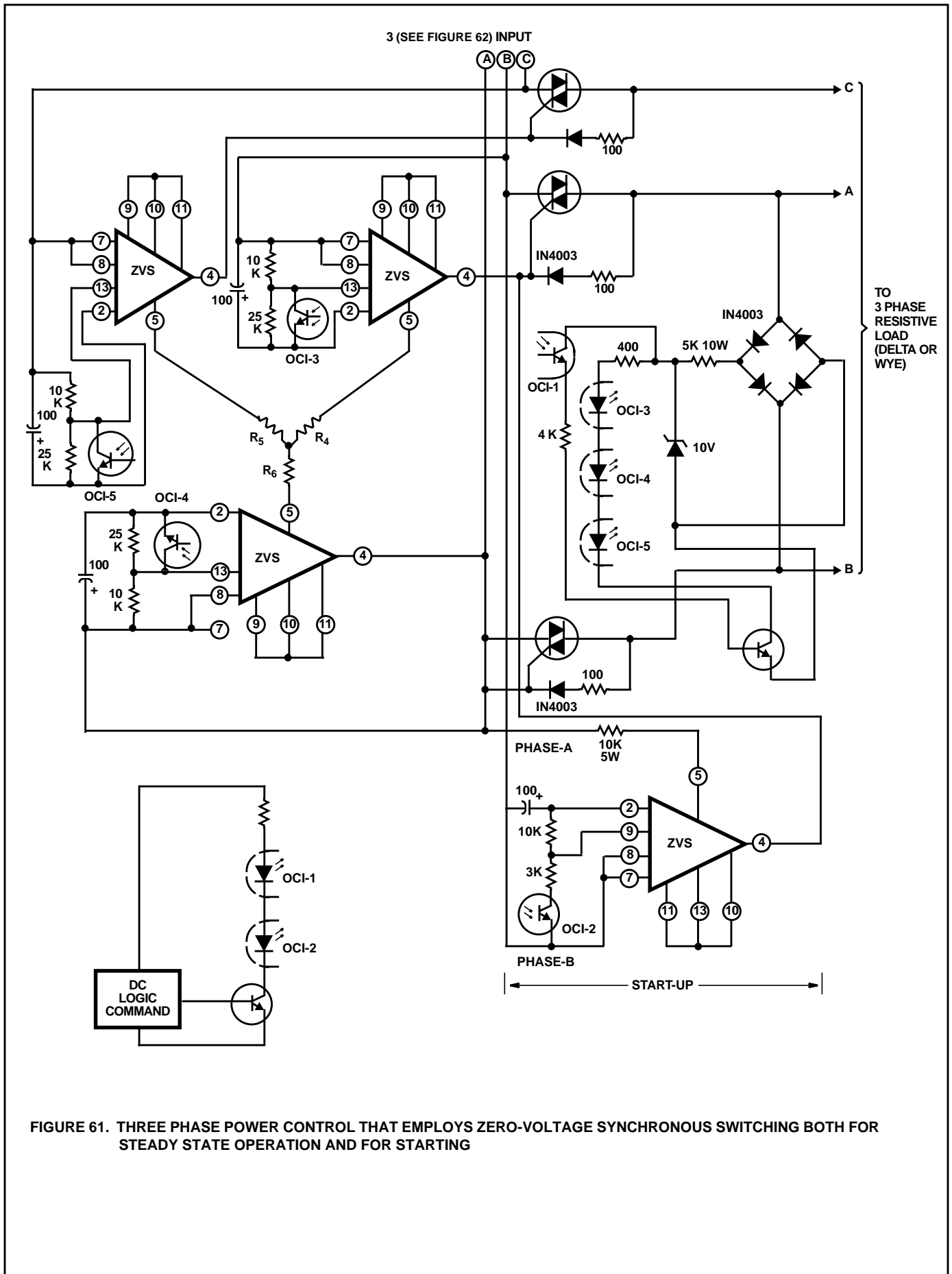

FIGURE 61. THREE PHASE POWER CONTROL THAT EMPLOYS ZERO-VOLTAGE SYNCHRONOUS SWITCHING BOTH FOR STEADY STATE OPERATION AND FOR STARTING

Application Note 6182

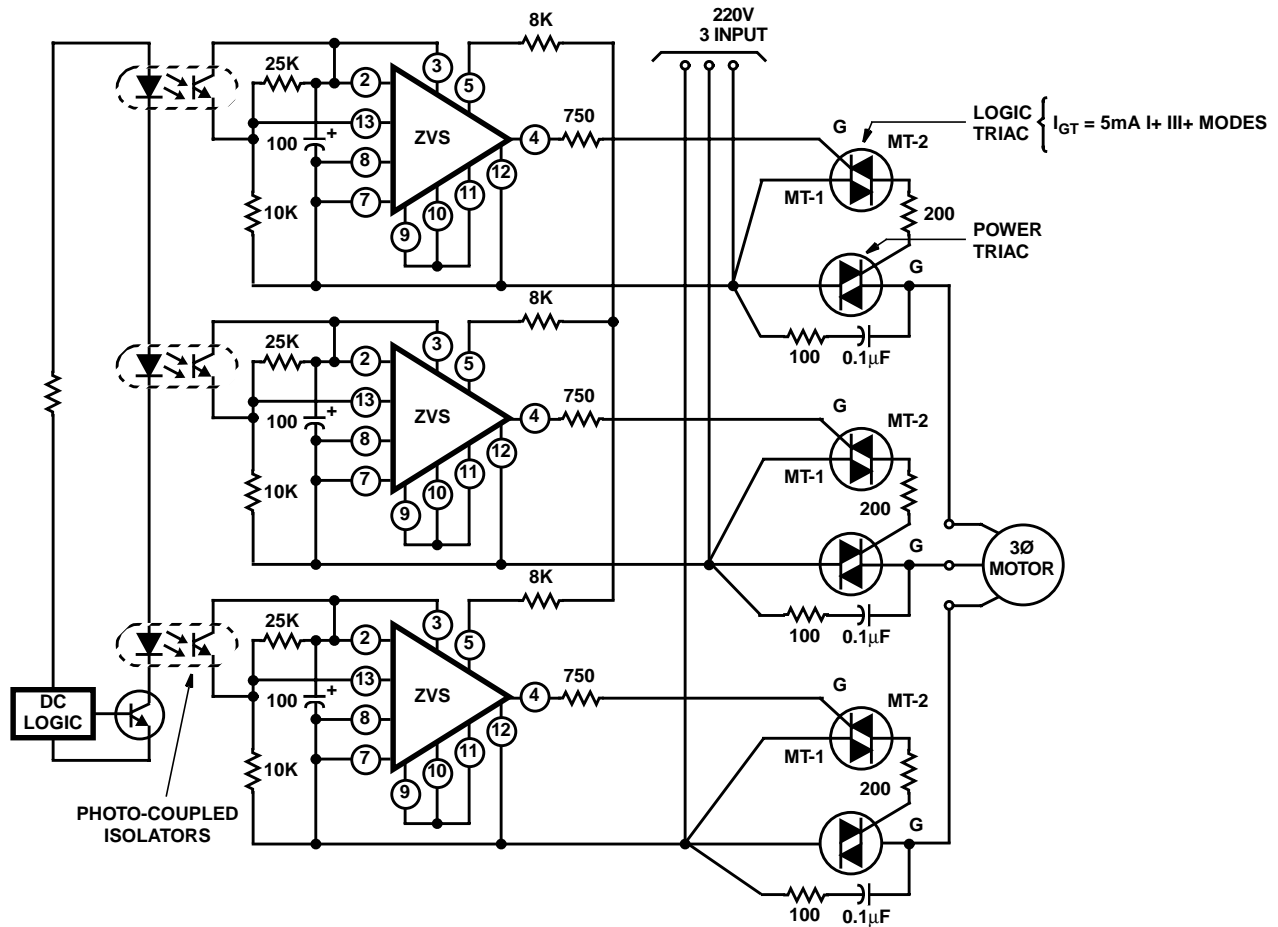

FIGURE 62. TRIAC THREE PHASE CONTROL CIRCUIT FOR AN INDUCTIVE LOAD, i.e., THREE PHASE MOTOR

All Intersil semiconductor products are manufactured, assembled and tested under **ISO9000** quality systems certification.

Intersil products are sold by description only. Intersil Corporation reserves the right to make changes in circuit design and/or specifications at any time without notice. Accordingly, the reader is cautioned to verify that data sheets are current before placing orders. Information furnished by Intersil is believed to be accurate and reliable. However, no responsibility is assumed by Intersil or its subsidiaries for its use; nor for any infringements of patents or other rights of third parties which may result from its use. No license is granted by implication or otherwise under any patent or patent rights of Intersil or its subsidiaries.

For information regarding Intersil Corporation and its products, see web site <http://www.intersil.com>

Sales Office Headquarters

NORTH AMERICA
Intersil Corporation
P. O. Box 883, Mail Stop 53-204
Melbourne, FL 32902
TEL: (407) 724-7000
FAX: (407) 724-7240

EUROPE
Intersil SA
Mercure Center
100, Rue de la Fusee
1130 Brussels, Belgium
TEL: (32) 2.724.2111
FAX: (32) 2.724.22.05

ASIA
Intersil (Taiwan) Ltd.
Taiwan Limited
7F-6, No. 101 Fu Hsing North Road
Taipei, Taiwan
Republic of China
TEL: (886) 2 2716 9310
FAX: (886) 2 2715 3029

Looking for pricing, stock, or lifecycle information?

Click below to explore more details on WIN SOURCE:

- ⊖ [View CA3059 on WIN SOURCE](#)
- ⊖ [Renesas Electronics America](#) Information

Optimize Your Supply Chain with WIN SOURCE Solutions

- ✓ Global Sourcing Solution
- ✓ Obsolete Management
- ✓ Cost Control Management
- ✓ Shortage Management
- ✓ Alternative Solution
- ✓ Excess Inventory Management