



**THE DATASHEET OF
PGA305EVM-034**



PGAxxxEVM-034 User Guide

The PGAxxxEVM-034 supplies a platform to test the PGA900, PGA300, and PGA305 in the QFN package. The EVM is shipped as either the PGA900EVM-034, the PGA300EVM-034, or the PGA305EVM-034, with the name identifying the signal conditioner included in the EVM package. The PGAxxxEVM-034 supplies an interchangeable platform all of these devices can use.

Contents

1	Introduction	2
2	Default Configuration	3
3	Inputs and Output Configurations	4
	3.1 Pressure Input	4
	3.2 Temperature Input	4
	3.3 Output	4
	3.4 Voltage Mode	5
	3.5 Current Mode	6
	3.6 OWI and SPI/I ² C/SWD in 4-mA to 20-mA Current Loop	7
4	OWI	10
	4.1 Activation Pulse	11
	4.2 Data Sent Through OWI	12
5	XDS200 and USB2ANY Connectors	13
6	Power Supplies in the PGAxxxEVM-034	16
7	Schematics	17

List of Figures

1	PGAxxxEVM-034	2
2	Pressure Stimulus in the PGAxxxEVM-034	4
3	PGA900 in Voltage Mode Configuration	5
4	PGAxxxEVM-034 in Current Mode	6
5	Additional Loop Current in 4-mA to 20-mA Mode When Using SPI/I ² C/SWD as Digital Interface	8
6	Additional Loop Current in 4-mA to 20-mA Mode When Using OWI as Digital Interface	9
7	OWI Block Diagram	10
8	OWI Activation Pulse for the PGA900 Generated by the PGAxxxEVM-034 in Voltage Mode	11
9	OWI Data at 320 bps; Oscilloscope Probe is Connected at TP20 in the PGAxxxEVM-034	12
10	XDS200 Emulator Connection to the PGAxxxEVM-034	13
11	USB2ANY Connection to the PGAxxxEVM-034	14
12	USB2ANY	14
13	USB2ANY Pinout	15
14	Power Distribution in PGAxxxEVM-034	16
15	PGAxxxEVM-034 Main Schematic	17
16	Input and Output Schematic	18
17	USB2ANY Schematic	19
18	OWI Activation Pulse and Data Schematic	20
19	OWI Power Amplifier Schematic	21
20	Power Supplies Schematic	22

Trademarks

All trademarks are the property of their respective owners.

1 Introduction

Figure 1 shows the PGAxxxEVM-034 and labels the primary sections.

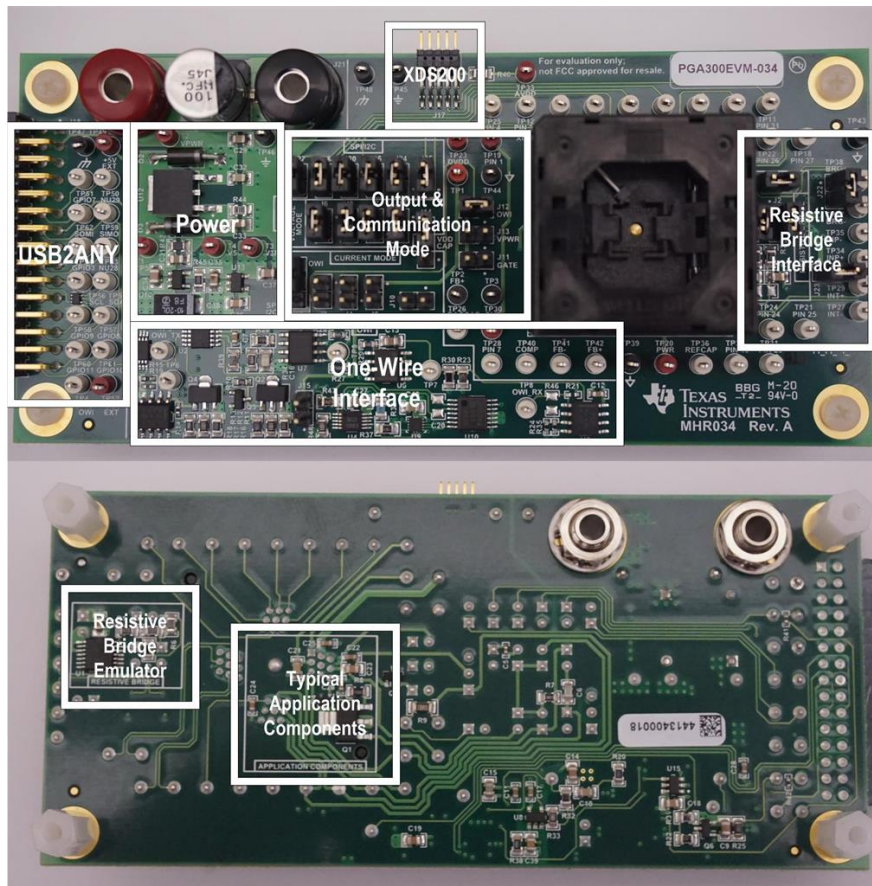

Figure 1. PGAxxxEVM-034

The PGAxxxEVM-034 is divided into six sections:

1. Interface boards and external power:
 - a. USB2ANY connector
 - b. XDS200 connector (single wire debugger)
 - c. Banana connectors to power up EVM
2. Power:
 - a. 7.5-V, 5-V, and 3.3-V regulators
3. Mode selection:
 - a. 4- to 20-mA loop (current mode)
 - b. Voltage mode
4. OWI circuitry
5. Resistive bridge
6. Application components

The application components section only lists the required components for real-life applications using the PGA900/PGA300/PGA305 device. In this case, the application is configured for current mode.

NOTE: The PGA900, PGA300, and PGA305 have different features and pin functions, and some circuitry and communication features found on the PGAxixEVM-034 are only applicable to the PGA900. Each device also has its own unique Graphical User Interface (GUI) that communicates with the included USB2ANY board.

2 Default Configuration

The EVM requires a 10- to 30-V input applied to J20 and J21. Clamp the power supply current to 100 mA. The shipped EVM is configured for voltage mode as shown in [Table 1](#).

Table 1. Jumper Settings for PGAxixEVM-034 in Voltage Mode

Jumper	Setting	Function
J12	Closed	PGAxix powered up from OWI circuitry (VDD = 5 V)
J1, J2, J3	Closed	Connect resistive bridge to PGA900
J6, J7, J8	Closed	Voltage mode with a 100-nF load
J24, J25, J26, J27, J28, J30	Closed	SPI/I ² C/UART enabled (only applicable to PGA900)
J16	Closed	Connect ASIC_GND to IRETURN
J14	Pins 1-2 closed	Connect VDD cap to ASIC_GND
J19	Pins 2-3 closed	Connect USBGND to IRETURN

3 Inputs and Output Configurations

3.1 Pressure Input

The PGAxxxEVM-034 has a resistive bridge where one leg of the bridge can be changed using a digital potentiometer. The changing leg has two digital potentiometers connected in parallel in series with a 4.7-k Ω resistor. J1 must be closed to connect the bridge voltage from the PGAxxx device to the resistive bridge. The J2 and J3 must also be closed to connect the bridge outputs to the PGAxxx. An RC filter is in series with each of the input pins in the PGAxxx with a cutoff frequency of approximately 106 Hz. Figure 2 shows the pressure stimulus circuit in the PGAxxxEVM-034.

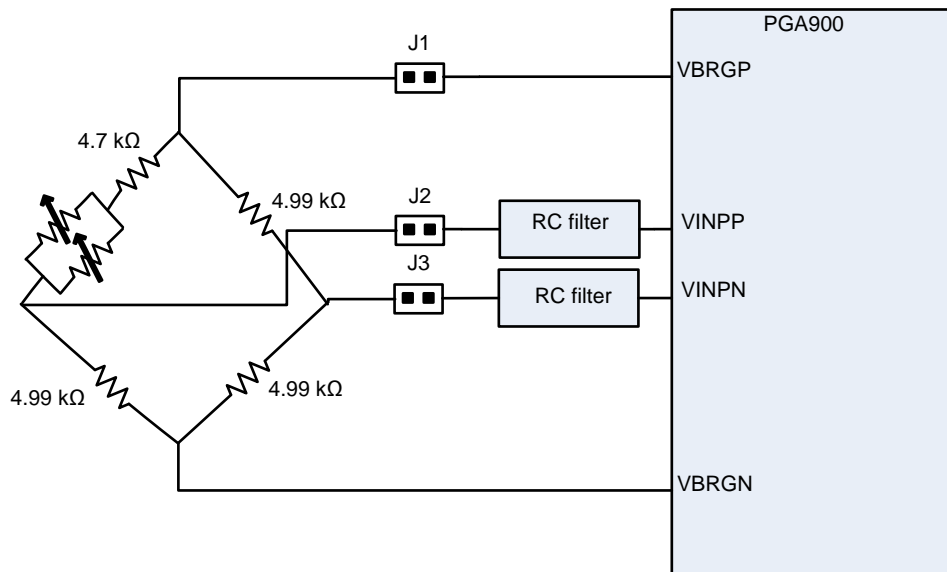

Figure 2. Pressure Stimulus in the PGAxxxEVM-034

3.2 Temperature Input

The PGAxxxEVM-034 does not have on-board stimulus for the temperature inputs of the PGAxxx, but the TP27 and TP29 on the far-right side of the board can be used to apply external signals.

3.3 Output

The PGAxxxEVM-034 can be configured for voltage or current mode (4-mA to 20-mA loop). Each mode requires different jumper settings as shown in the following sections.

3.4 Voltage Mode

The PGAx_{xx}EVM-034 is by default configured in voltage mode with a 100-nF load. A compensation capacitor and an isolation resistor are necessary for stability. Figure 3 shows the PGAx_{xx} schematic for voltage mode and Table 1 shows all the jumpers necessary to configure the board in this mode. If the capacitive load is different from 100 nF, then the isolation resistor and compensation capacitor values must be changed. Refer to the application note *PGA900 as a Capacitive Load Driver* (SLDA020) for more information.

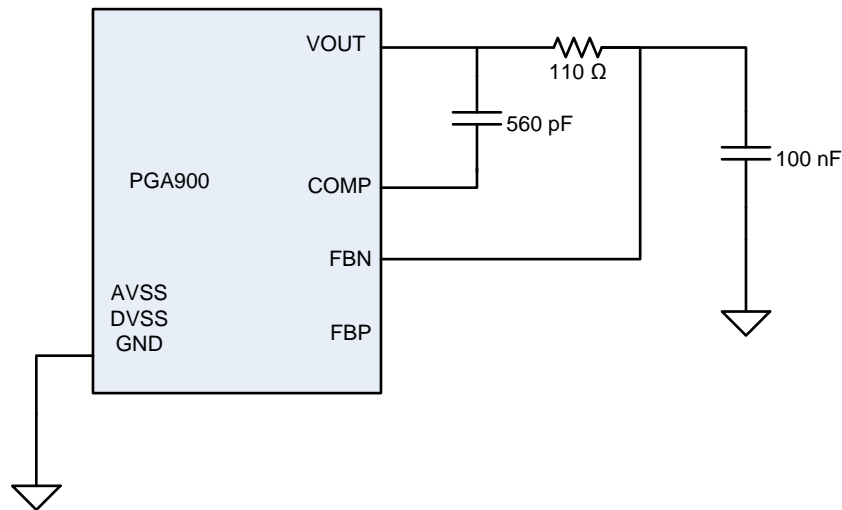

Figure 3. PGA900 in Voltage Mode Configuration

NOTE: If the designer wants the VDD to be higher than 5 V in voltage mode, open J12 and close J13. VDD will be equal to the power applied to the PGAx_{xx}EVM-034.

3.5 Current Mode

When in current mode, the PGAxxxEVM-034 must be properly configured to separate the different negative references for all the voltage levels present in the board. Figure 4 shows the primary connections for current mode. The two scenarios in current mode are:

- Current mode using OWI
- Current mode using SPI/I²C/SWD (only applicable to the PGA900 or the PGA305 in I²C mode)

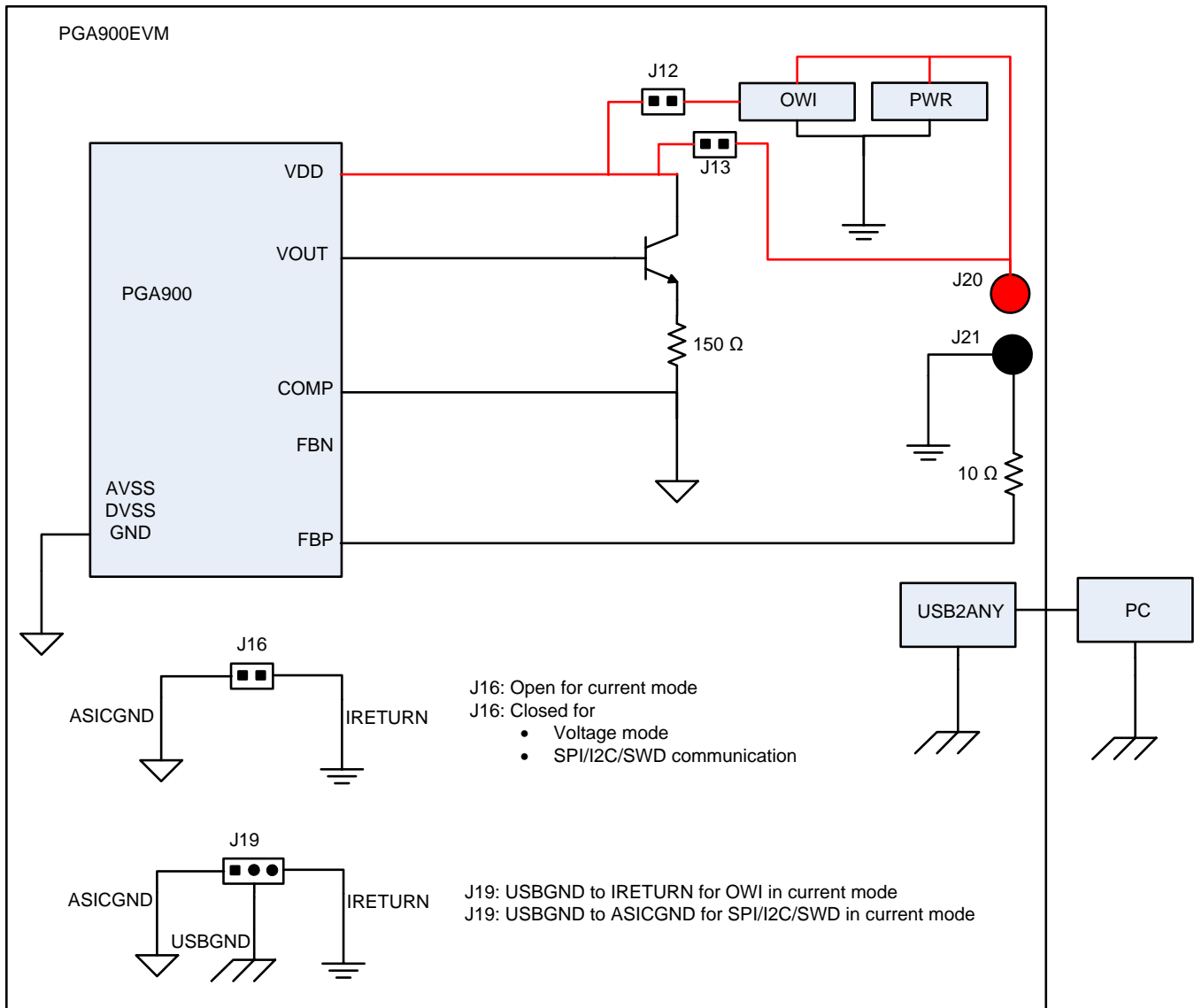

Figure 4. PGAxxxEVM-034 in Current Mode

NOTE: When in current mode, the input voltage to the EVM (J20 and J21) should be at least 20 V.

3.6 OWI and SPI/I²C/SWD in 4-mA to 20-mA Current Loop

Remember that when in current mode, there are two different scenarios depending on whether OWI or SPI/I²C/SWD will be used as the type of communication for the PGA900. The PGA300 only allows communication through OWI, so always follow the settings found on [Table 3](#) when using the PGA300 in current mode. [Table 2](#) shows the jumper settings necessary for each of these scenarios. Refer to [Figure 4](#) for the locations of the jumpers. The PGA305 allows communication through OWI or through I²C. When using OWI communication with the PGA305 device in current mode, refer to the same settings used for the PGA300 listed earlier. For I²C communication with the PGA305 in current mode, use the same settings as those used for I²C communication with the PGA900 in current mode.

Table 2. Jumper Settings for PGA900EVM-034 in Current Mode Using SPI/I²C/SWD

Jumper	Setting	Function
J16	Open	Disconnect ASIC_GND from IRETURN
J19	Pins 1-2 closed	Connect USBGND to ASICGND
J13	Closed	Connect PGA900 VDD pin to EVM input voltage
J6	Open	Disconnect 180 pF between COMP and VOUT
J9	Closed	Connect COMP to ASIC_GND
J4	Closed	Short out resistor at VOUT
J8	Open	Disconnect FBN from VOUT
J5	Closed	Connect VOUT to BJT
J7	Open	Lift 100-nF Voltage-mode load Capacitor at base of BJT
J10	Closed	Connect FBP to IRETURN through 10-Ω resistor
J14	Pins 1-2 closed	100-nF capacitor from VDD to FBP and from DACCAP to FBP
J12	Open	Disconnect PGA900 VDD pin from OWI signal from EVM
J25, J27	Closed	If I ² C is desired
J24, J26, J28, J30	Closed	If SPI/UART is desired

Table 3. Jumper Settings for PGAXxxEVM-034 in Current Mode Using OWI

Jumper	Setting	Function
J16	Open	Disconnect ASIC_GND from IRETURN
J19	Pins 2-3 closed	Connect USBGND to IRETURN
J13	Open	Disconnect PGA900 VDD pin from EVM input voltage
J6	Open	Disconnect 560 pF between COMP and VOUT
J9	Closed	Connect COMP to ASIC_GND
J4	Closed	Short out resistor at VOUT
J8	Open	Disconnect FBN from VOUT
J5	Closed	Connect VOUT to BJT
J7	Open	Lift 100-nF Voltage-mode load Capacitor at base of BJT
J10	Closed	Connect FBP to IRETURN through 10-Ω resistor
J14	Pins 1-2 closed	100-nF capacitor from VDD to FBP and from DACCAP to FBP
J12	Closed	Connect VDD in PGA900 to OWI signal from EVM
J25, J27	Open	Disconnect I ² C pins between USB2ANY and PGA900
J24, J26, J28, J30	Open	Disconnect SPI/UART pins between USB2ANY and PGA900

The PGA300 and PGA305 are prepared for OWI communication and do not require additional device configuration.

For the PGA900, OWI in current mode can only be used with appropriate firmware programmed in the device. The firmware should:

1. Enable the OWI interrupt and service it when the activation sequence on VDD is received by the device.
2. Set the deglitch time to the 1-ms default time (OWI_DGL_CNT_SEL = 0).
3. Disconnect the DAC output from the loop by setting bit 0 of AMUX_CTRL to 0.
4. Enable the OWI transceiver and reset M0 by writing 0x03 to MICRO_INTERFACE_CONTROL register.

When in 4-mA to 20-mA loop configuration, there is additional current from ASIC_GND (GND of PGA900) to IRETURN (return path for the loop current) that is caused by the voltage difference created by the 40-Ω resistor inside the PGA900 and the 10-Ω (R9) EVM resistor. This additional current is due to the U11 (when in SPI/I2C/SWD communication) and U1 (digital potentiometer in the resistive bridge). Figure 5 and Figure 6 show this additional current. As a result, the designer should lift J22 and J23 to isolate U1 and should use OWI when using the PGAXxxEVM-034 if they want accurate calibration (firmware required) in 4-mA to 20-mA mode.

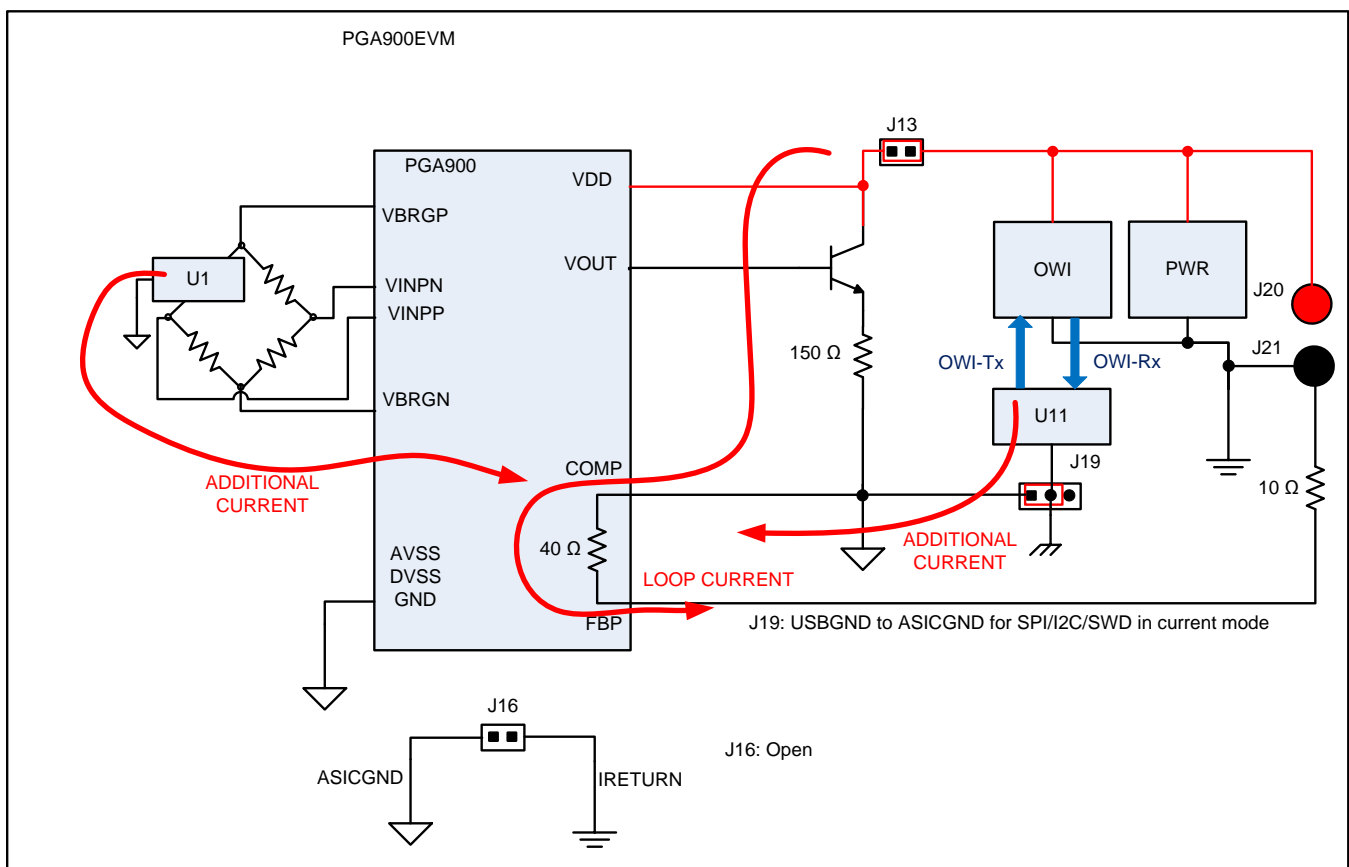

Figure 5. Additional Loop Current in 4-mA to 20-mA Mode When Using SPI/I2C/SWD as Digital Interface

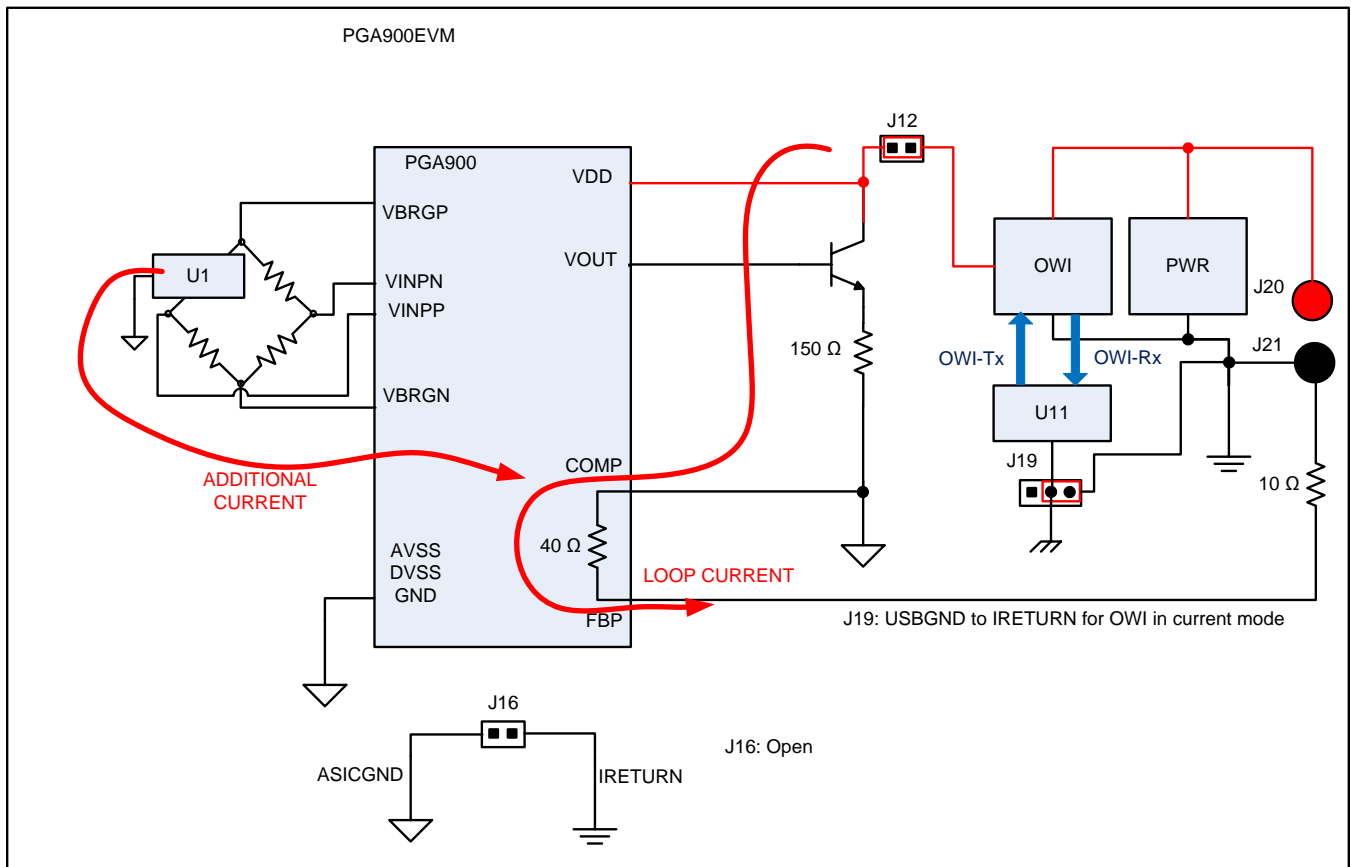

Figure 6. Additional Loop Current in 4-mA to 20-mA Mode When Using OWI as Digital Interface

4.1 Activation Pulse

The activation pulse generated by the PGAxixEVM-034 generates the OWI interrupt necessary to activate the OWI (with the proper firmware developed by the user). [Figure 8](#) shows the activation pulse from the PGAxixEVM-034.

- In the PGA900 and PGA305 GUIs, to use this activation pulse, select the “Through Pulse” option from the “OWI Activation Mode” menu and then click “OWI”. The duration of the activation pulse varies due to software delays, but the minimum requirement of 1 or 10 ms is always met. If the pulse is not necessary, OWI can also be enabled through I²C. To select this option, select “Through I2C” from the “OWI Activation Mode” menu, and then click “OWI”.
- In the PGA300 GUI, the activation pulse is sent as soon as the designer presses “Activate OWI”. The pulse is sent as defined in the PGA300 data sheet ([SLDS204](#)).

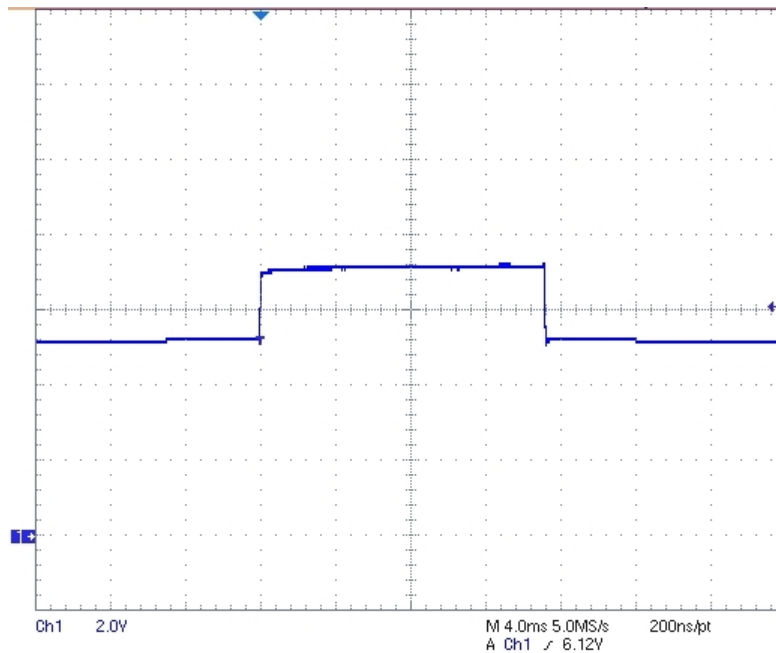

Figure 8. OWI Activation Pulse for the PGA900 Generated by the PGAxixEVM-034 in Voltage Mode

4.2 Data Sent Through OWI

Data through OWI can be sent to the PGA900/PGA300/PGA305 at rates between 320 to 9600 bps. Figure 9 shows data sent at 320 bps.

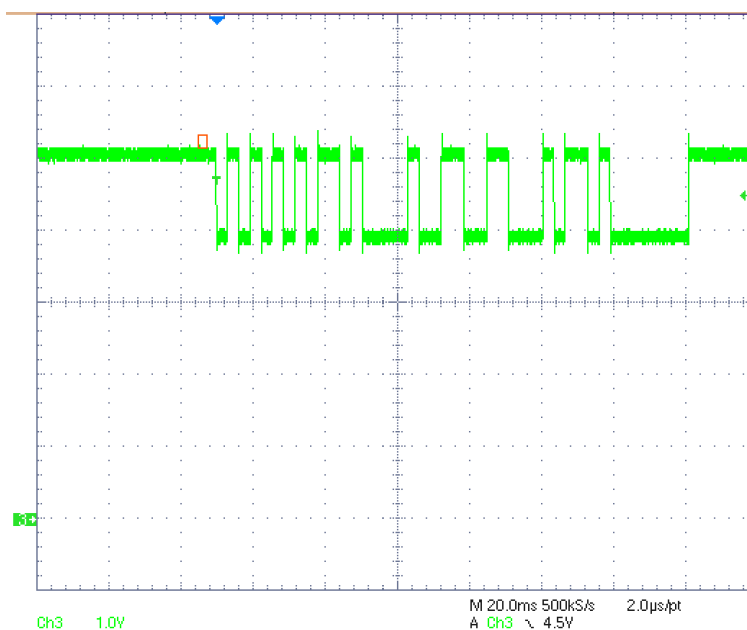

Figure 9. OWI Data at 320 bps; Oscilloscope Probe is Connected at TP20 in the PGAxixEVM-034

The USB2ANY is used for the different communication protocols supplied by the PGA900/PGA300/PGA305. The USB2ANY connects to J18 in the PGxxxEVM-034 as shown in [Figure 11](#). The USB2ANY hardware is based on the TI MSP430F5529, 16-bit microcontroller with integrated USB 2.0. The PCB is a two-layer, single-sided board with minimal component count. There are two versions of the USB2ANY, shown in [Figure 12](#), one enclosed and one open. The functionality is the same for both.

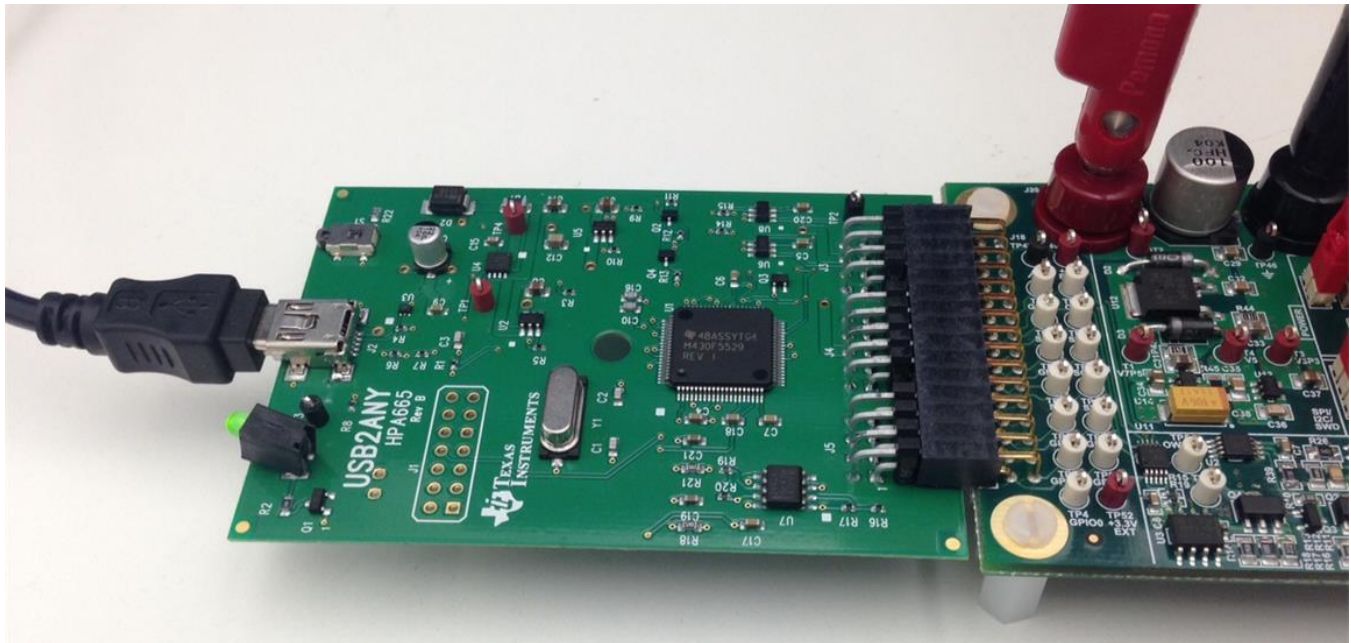

Figure 11. USB2ANY Connection to the PGxxxEVM-034



Figure 12. USB2ANY

Figure 13 shows the pinout of the USB2ANY. The ribbon cable can only be connected one way to the USB2ANY due to a latch present in the cable. A USB cable is included to connect the device to the PC. No external supply is necessary.

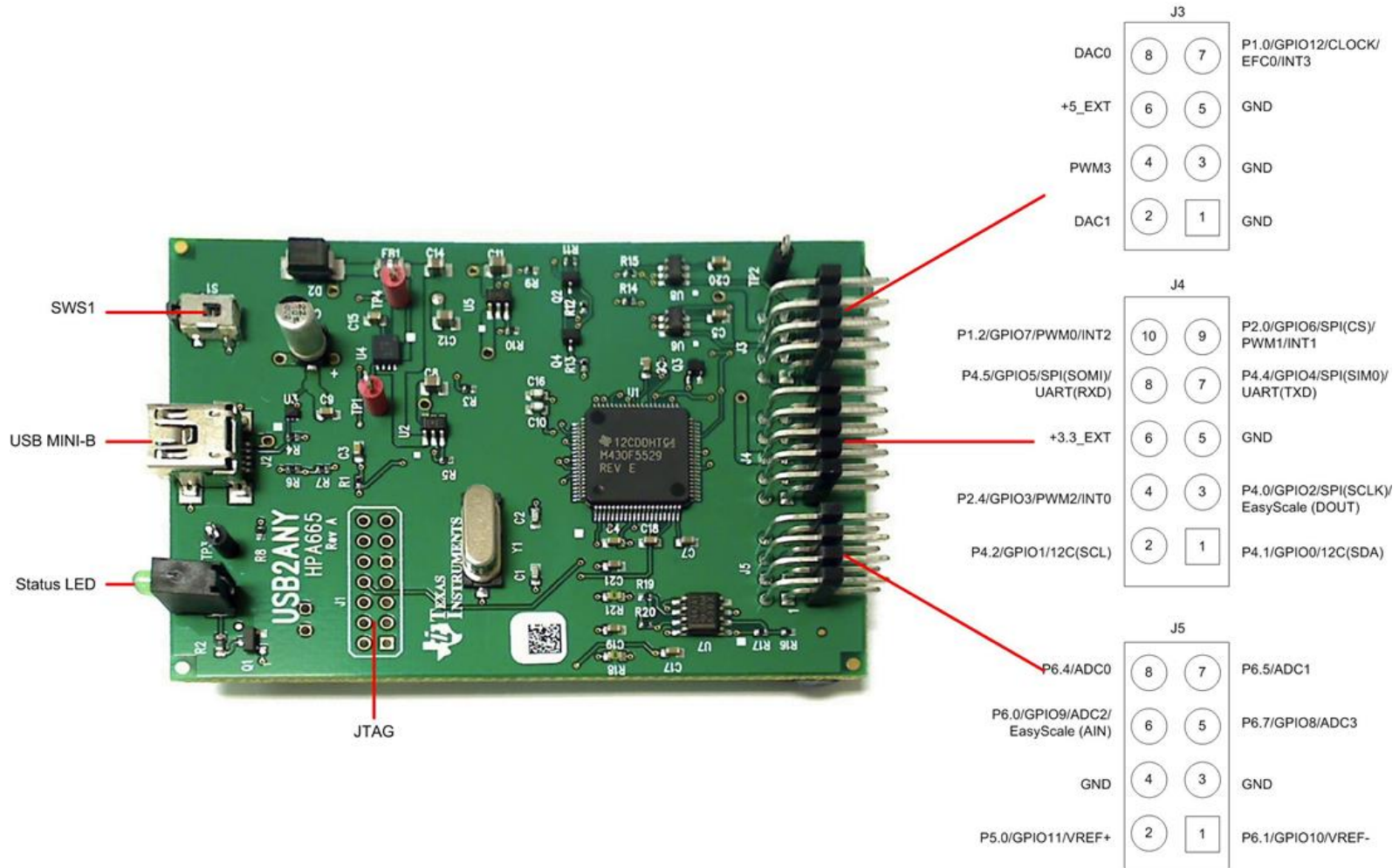

Figure 13. USB2ANY Pinout

6 Power Supplies in the PGAxXXEVM-034

The PGAxXXEVM-034 requires an input voltage between 10 V to 30 V to properly operate. [Figure 14](#) shows the different power options in the PGAxXXEVM-034.

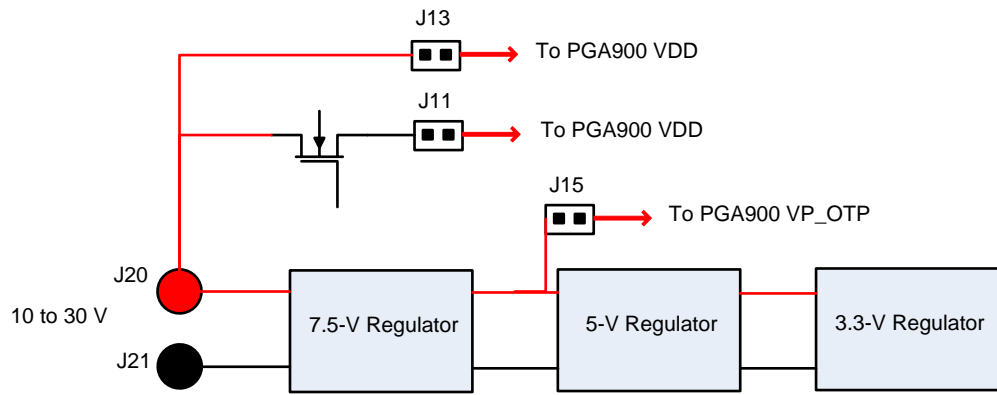

Figure 14. Power Distribution in PGAxXXEVM-034

NOTE: J15 must be closed during OTP programming. This is only applicable for the PGA900. The PGA300 has no OTP functionality.

7 Schematics

Figure 15 through Figure 20 show the PGAxxxEVM-034 schematics.

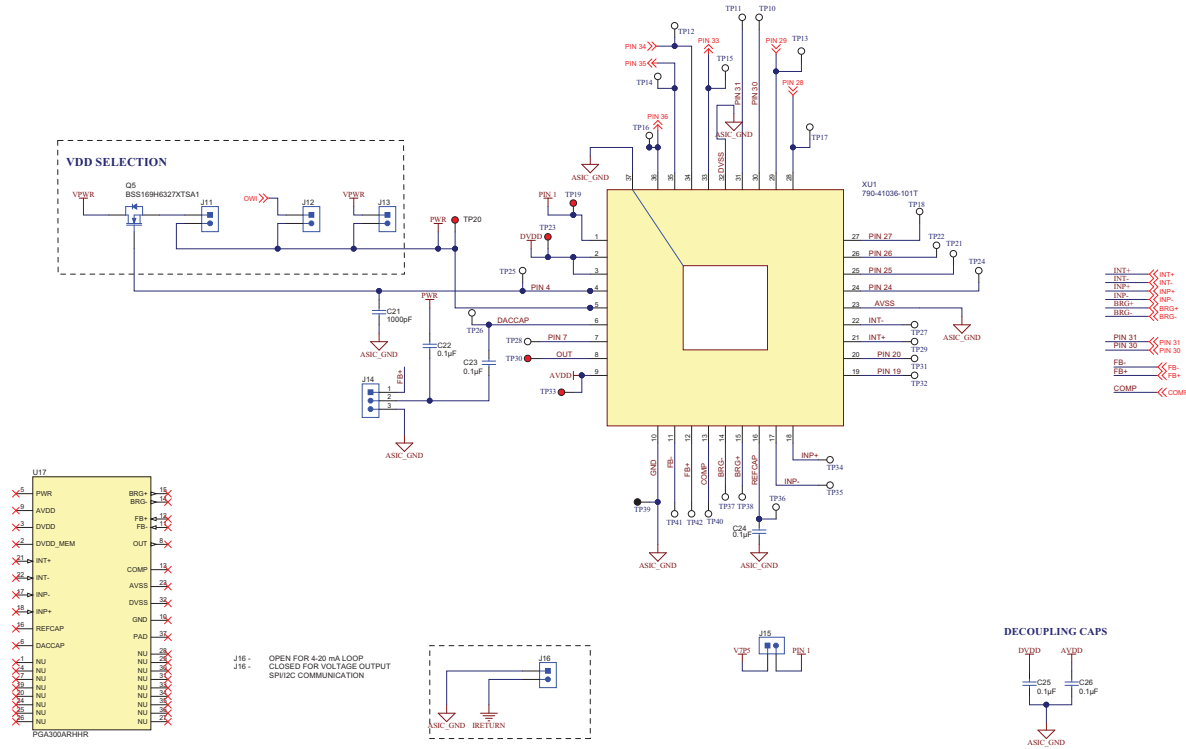
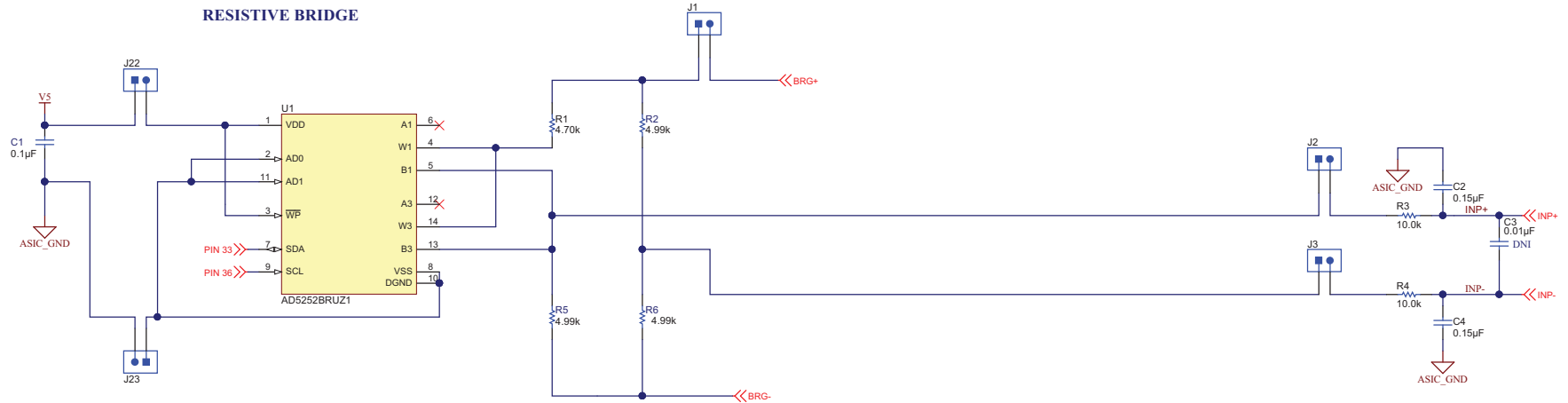

Figure 15. PGAxxxEVM-034 Main Schematic



DAC OUTPUT CONFIGURATIONS

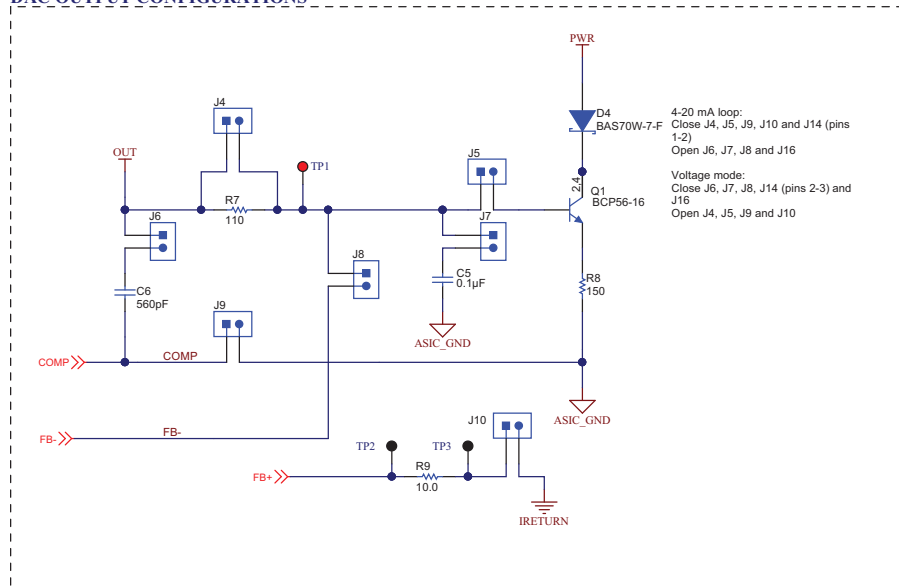
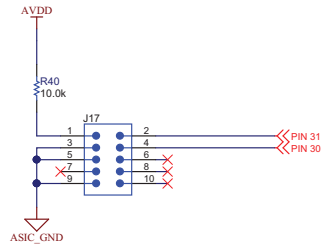
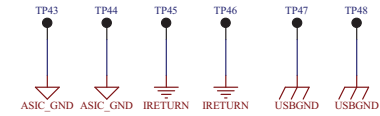

Figure 16. Input and Output Schematic

XDS200



GND TEST POINTS



USB2ANY

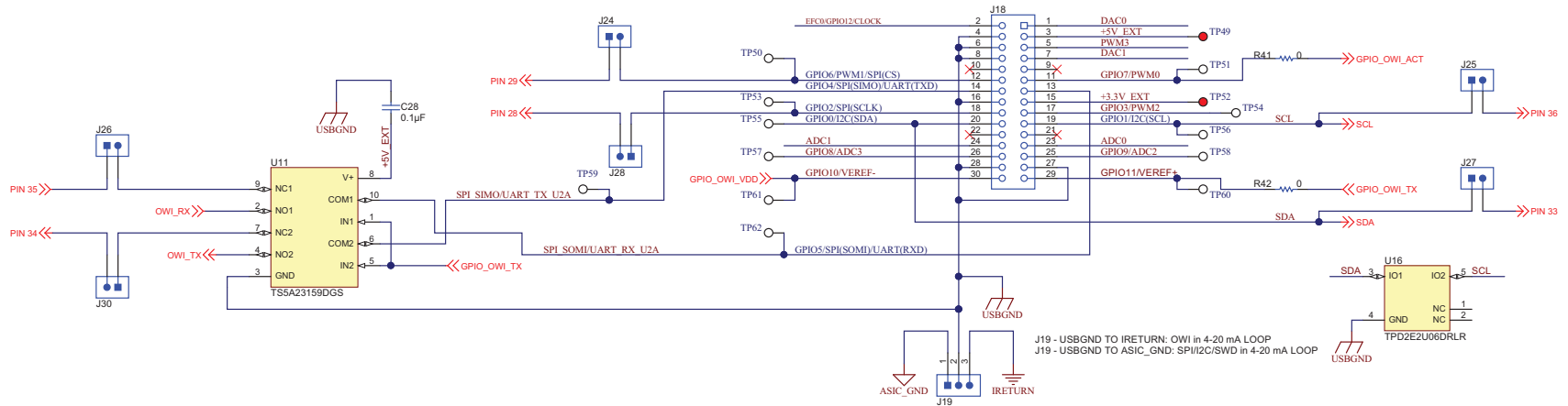

Figure 17. USB2ANY Schematic

OWI ACTIVATION PULSE AND DATA

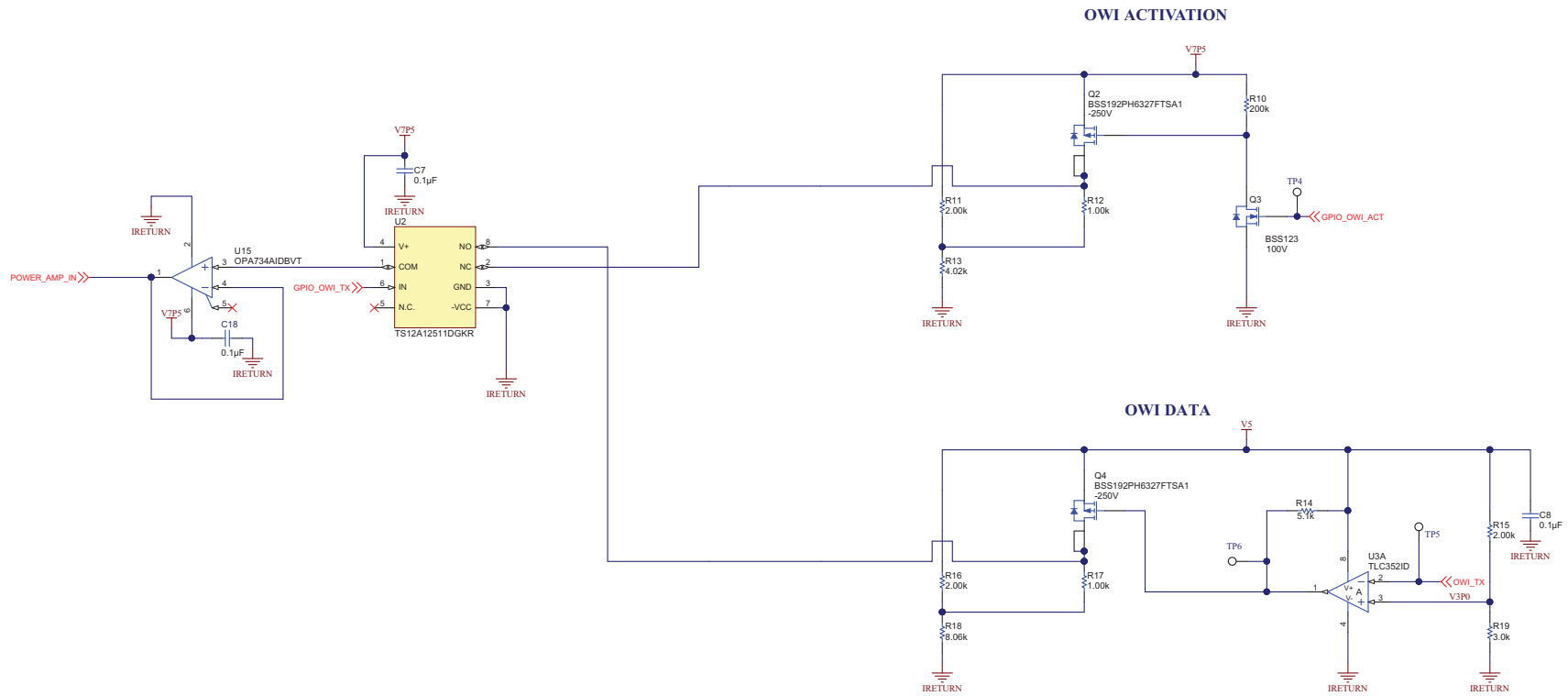

Figure 18. OWI Activation Pulse and Data Schematic

OWI

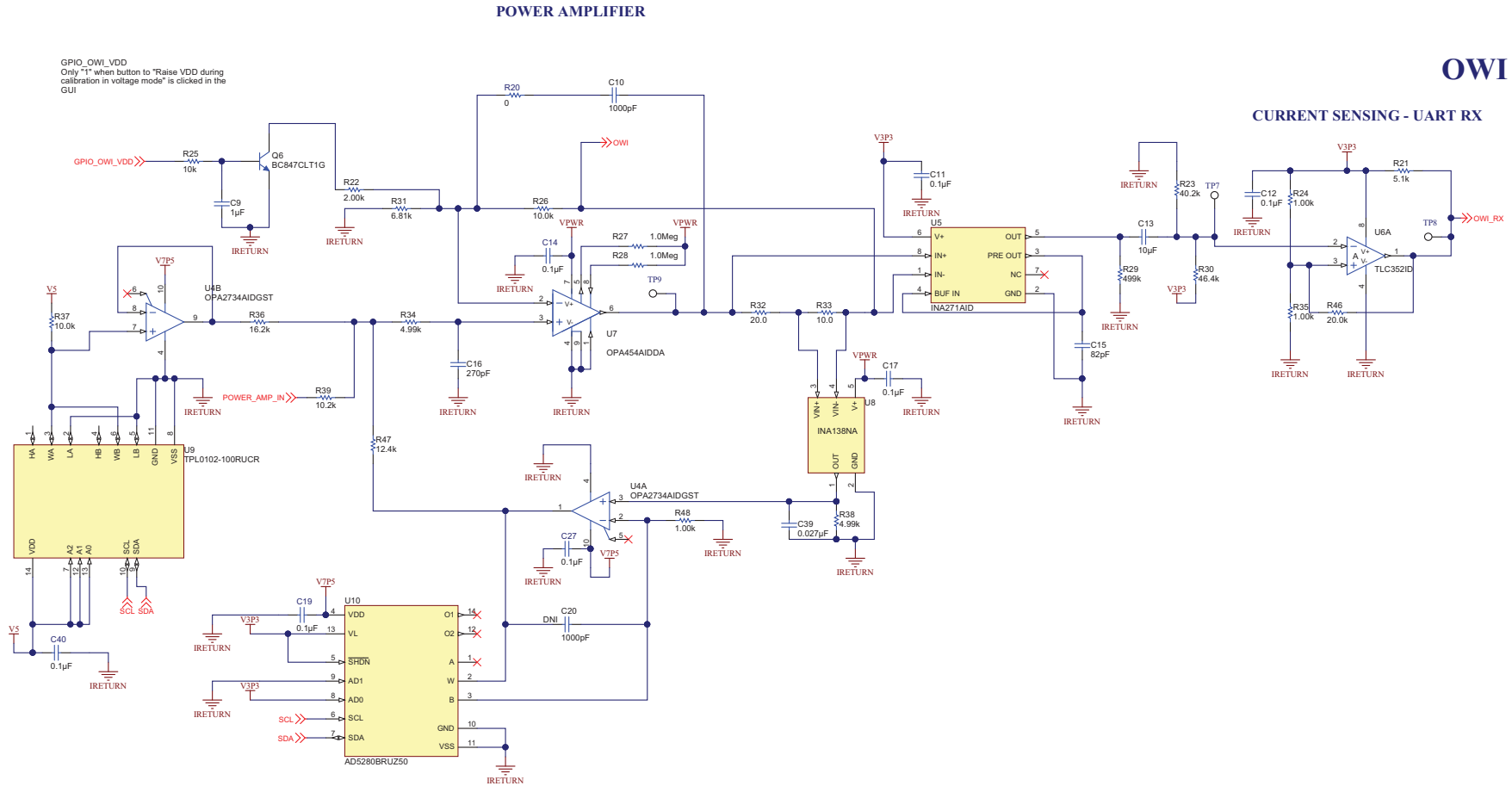
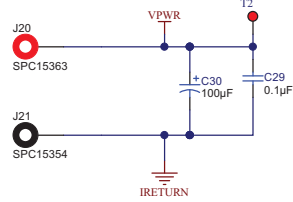

Figure 19. OWI Power Amplifier Schematic

POWER SUPPLIES

10V - 30V PGA900EVM input



7.5V Regulator

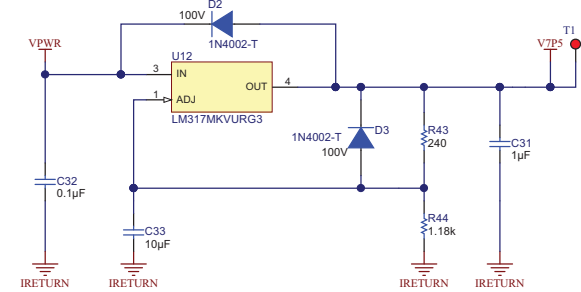

5V Regulator

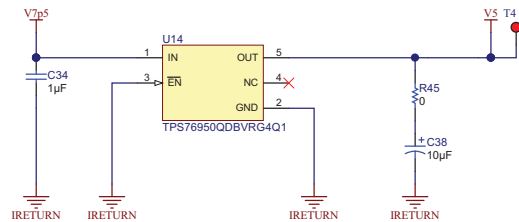

3.3V Regulator

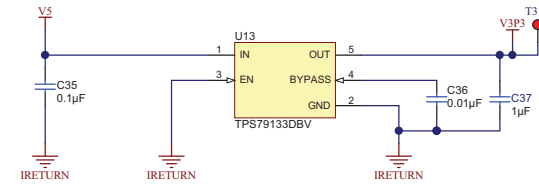

Figure 20. Power Supplies Schematic

Revision History

NOTE: Page numbers for previous revisions may differ from page numbers in the current version.

Changes from A Revision (June 2016) to B Revision Page

- Added references for PGA305EVM..... 1
-

Changes from Original (May 2015) to A Revision Page

- Updated [Table 2](#)..... 7
 - Added [Table 3](#) 7
 - Additional current discussion when in 4-mA to 20-mA mode..... 8
 - Added [Figure 5](#) 8
 - Added [Figure 6](#) 9
 - Added note regarding jumper for OTP voltage 16
 - Updated designator for J16 in [Figure 15](#) 17
 - Updated designators for text in DAC Output Configurations in [Figure 16](#) 18
 - Updated designator for J19 in [Figure 17](#) 19
-

STANDARD TERMS FOR EVALUATION MODULES

1. *Delivery:* TI delivers TI evaluation boards, kits, or modules, including any accompanying demonstration software, components, and/or documentation which may be provided together or separately (collectively, an "EVM" or "EVMs") to the User ("User") in accordance with the terms set forth herein. User's acceptance of the EVM is expressly subject to the following terms.
 - 1.1 EVMs are intended solely for product or software developers for use in a research and development setting to facilitate feasibility evaluation, experimentation, or scientific analysis of TI semiconductor products. EVMs have no direct function and are not finished products. EVMs shall not be directly or indirectly assembled as a part or subassembly in any finished product. For clarification, any software or software tools provided with the EVM ("Software") shall not be subject to the terms and conditions set forth herein but rather shall be subject to the applicable terms that accompany such Software
 - 1.2 EVMs are not intended for consumer or household use. EVMs may not be sold, sublicensed, leased, rented, loaned, assigned, or otherwise distributed for commercial purposes by Users, in whole or in part, or used in any finished product or production system.
2. *Limited Warranty and Related Remedies/Disclaimers:*
 - 2.1 These terms do not apply to Software. The warranty, if any, for Software is covered in the applicable Software License Agreement.
 - 2.2 TI warrants that the TI EVM will conform to TI's published specifications for ninety (90) days after the date TI delivers such EVM to User. Notwithstanding the foregoing, TI shall not be liable for a nonconforming EVM if (a) the nonconformity was caused by neglect, misuse or mistreatment by an entity other than TI, including improper installation or testing, or for any EVMs that have been altered or modified in any way by an entity other than TI, (b) the nonconformity resulted from User's design, specifications or instructions for such EVMs or improper system design, or (c) User has not paid on time. Testing and other quality control techniques are used to the extent TI deems necessary. TI does not test all parameters of each EVM. User's claims against TI under this Section 2 are void if User fails to notify TI of any apparent defects in the EVMs within ten (10) business days after delivery, or of any hidden defects with ten (10) business days after the defect has been detected.
 - 2.3 TI's sole liability shall be at its option to repair or replace EVMs that fail to conform to the warranty set forth above, or credit User's account for such EVM. TI's liability under this warranty shall be limited to EVMs that are returned during the warranty period to the address designated by TI and that are determined by TI not to conform to such warranty. If TI elects to repair or replace such EVM, TI shall have a reasonable time to repair such EVM or provide replacements. Repaired EVMs shall be warranted for the remainder of the original warranty period. Replaced EVMs shall be warranted for a new full ninety (90) day warranty period.
3. *Regulatory Notices:*
 - 3.1 *United States*
 - 3.1.1 *Notice applicable to EVMs not FCC-Approved:*

FCC NOTICE: This kit is designed to allow product developers to evaluate electronic components, circuitry, or software associated with the kit to determine whether to incorporate such items in a finished product and software developers to write software applications for use with the end product. This kit is not a finished product and when assembled may not be resold or otherwise marketed unless all required FCC equipment authorizations are first obtained. Operation is subject to the condition that this product not cause harmful interference to licensed radio stations and that this product accept harmful interference. Unless the assembled kit is designed to operate under part 15, part 18 or part 95 of this chapter, the operator of the kit must operate under the authority of an FCC license holder or must secure an experimental authorization under part 5 of this chapter.
 - 3.1.2 *For EVMs annotated as FCC – FEDERAL COMMUNICATIONS COMMISSION Part 15 Compliant:*

CAUTION

This device complies with part 15 of the FCC Rules. Operation is subject to the following two conditions: (1) This device may not cause harmful interference, and (2) this device must accept any interference received, including interference that may cause undesired operation.

Changes or modifications not expressly approved by the party responsible for compliance could void the user's authority to operate the equipment.

FCC Interference Statement for Class A EVM devices

NOTE: This equipment has been tested and found to comply with the limits for a Class A digital device, pursuant to part 15 of the FCC Rules. These limits are designed to provide reasonable protection against harmful interference when the equipment is operated in a commercial environment. This equipment generates, uses, and can radiate radio frequency energy and, if not installed and used in accordance with the instruction manual, may cause harmful interference to radio communications. Operation of this equipment in a residential area is likely to cause harmful interference in which case the user will be required to correct the interference at his own expense.

FCC Interference Statement for Class B EVM devices

NOTE: This equipment has been tested and found to comply with the limits for a Class B digital device, pursuant to part 15 of the FCC Rules. These limits are designed to provide reasonable protection against harmful interference in a residential installation. This equipment generates, uses and can radiate radio frequency energy and, if not installed and used in accordance with the instructions, may cause harmful interference to radio communications. However, there is no guarantee that interference will not occur in a particular installation. If this equipment does cause harmful interference to radio or television reception, which can be determined by turning the equipment off and on, the user is encouraged to try to correct the interference by one or more of the following measures:

- Reorient or relocate the receiving antenna.
- Increase the separation between the equipment and receiver.
- Connect the equipment into an outlet on a circuit different from that to which the receiver is connected.
- Consult the dealer or an experienced radio/TV technician for help.

3.2 Canada

3.2.1 For EVMs issued with an Industry Canada Certificate of Conformance to RSS-210 or RSS-247

Concerning EVMs Including Radio Transmitters:

This device complies with Industry Canada license-exempt RSSs. Operation is subject to the following two conditions:

(1) this device may not cause interference, and (2) this device must accept any interference, including interference that may cause undesired operation of the device.

Concernant les EVMs avec appareils radio:

Le présent appareil est conforme aux CNR d'Industrie Canada applicables aux appareils radio exempts de licence. L'exploitation est autorisée aux deux conditions suivantes: (1) l'appareil ne doit pas produire de brouillage, et (2) l'utilisateur de l'appareil doit accepter tout brouillage radioélectrique subi, même si le brouillage est susceptible d'en compromettre le fonctionnement.

Concerning EVMs Including Detachable Antennas:

Under Industry Canada regulations, this radio transmitter may only operate using an antenna of a type and maximum (or lesser) gain approved for the transmitter by Industry Canada. To reduce potential radio interference to other users, the antenna type and its gain should be so chosen that the equivalent isotropically radiated power (e.i.r.p.) is not more than that necessary for successful communication. This radio transmitter has been approved by Industry Canada to operate with the antenna types listed in the user guide with the maximum permissible gain and required antenna impedance for each antenna type indicated. Antenna types not included in this list, having a gain greater than the maximum gain indicated for that type, are strictly prohibited for use with this device.

Concernant les EVMs avec antennes détachables

Conformément à la réglementation d'Industrie Canada, le présent émetteur radio peut fonctionner avec une antenne d'un type et d'un gain maximal (ou inférieur) approuvé pour l'émetteur par Industrie Canada. Dans le but de réduire les risques de brouillage radioélectrique à l'intention des autres utilisateurs, il faut choisir le type d'antenne et son gain de sorte que la puissance isotrope rayonnée équivalente (p.i.r.e.) ne dépasse pas l'intensité nécessaire à l'établissement d'une communication satisfaisante. Le présent émetteur radio a été approuvé par Industrie Canada pour fonctionner avec les types d'antenne énumérés dans le manuel d'usage et ayant un gain admissible maximal et l'impédance requise pour chaque type d'antenne. Les types d'antenne non inclus dans cette liste, ou dont le gain est supérieur au gain maximal indiqué, sont strictement interdits pour l'exploitation de l'émetteur.

3.3 Japan

3.3.1 *Notice for EVMs delivered in Japan:* Please see http://www.tij.co.jp/lstds/ti_ja/general/eStore/notice_01.page 日本国内に輸入される評価用キット、ボードについては、次のところをご覧ください。
http://www.tij.co.jp/lstds/ti_ja/general/eStore/notice_01.page

3.3.2 *Notice for Users of EVMs Considered "Radio Frequency Products" in Japan:* EVMs entering Japan may not be certified by TI as conforming to Technical Regulations of Radio Law of Japan.

If User uses EVMs in Japan, not certified to Technical Regulations of Radio Law of Japan, User is required to follow the instructions set forth by Radio Law of Japan, which includes, but is not limited to, the instructions below with respect to EVMs (which for the avoidance of doubt are stated strictly for convenience and should be verified by User):

1. Use EVMs in a shielded room or any other test facility as defined in the notification #173 issued by Ministry of Internal Affairs and Communications on March 28, 2006, based on Sub-section 1.1 of Article 6 of the Ministry's Rule for Enforcement of Radio Law of Japan,
2. Use EVMs only after User obtains the license of Test Radio Station as provided in Radio Law of Japan with respect to EVMs, or
3. Use of EVMs only after User obtains the Technical Regulations Conformity Certification as provided in Radio Law of Japan with respect to EVMs. Also, do not transfer EVMs, unless User gives the same notice above to the transferee. Please note that if User does not follow the instructions above, User will be subject to penalties of Radio Law of Japan.

【無線電波を送信する製品の開発キットをお使いになる際の注意事項】 開発キットの中には技術基準適合証明を受けていないものがあります。技術適合証明を受けていないものご使用に際しては、電波法遵守のため、以下のいずれかの措置を取っていただく必要がありますのでご注意ください。

1. 電波法施行規則第6条第1項第1号に基づく平成18年3月28日総務省告示第173号で定められた電波暗室等の試験設備でご使用いただく。
2. 実験局の免許を取得後ご使用いただく。
3. 技術基準適合証明を取得後ご使用いただく。

なお、本製品は、上記の「ご使用にあたっての注意」を譲渡先、移転先に通知しない限り、譲渡、移転できないものとします。

上記を遵守頂けない場合は、電波法の罰則が適用される可能性があることをご留意ください。日本テキサス・インスツルメンツ株式会社
東京都新宿区西新宿 6 丁目 2 4 番 1 号
西新宿三井ビル

3.3.3 *Notice for EVMs for Power Line Communication:* Please see http://www.tij.co.jp/lstds/ti_ja/general/eStore/notice_02.page
電力線搬送波通信についての開発キットをお使いになる際の注意事項については、次のところをご覧ください。 http://www.tij.co.jp/lstds/ti_ja/general/eStore/notice_02.page

3.4 *European Union*

3.4.1 *For EVMs subject to EU Directive 2014/30/EU (Electromagnetic Compatibility Directive):*

This is a class A product intended for use in environments other than domestic environments that are connected to a low-voltage power-supply network that supplies buildings used for domestic purposes. In a domestic environment this product may cause radio interference in which case the user may be required to take adequate measures.

4 *EVM Use Restrictions and Warnings:*

4.1 EVMS ARE NOT FOR USE IN FUNCTIONAL SAFETY AND/OR SAFETY CRITICAL EVALUATIONS, INCLUDING BUT NOT LIMITED TO EVALUATIONS OF LIFE SUPPORT APPLICATIONS.

4.2 User must read and apply the user guide and other available documentation provided by TI regarding the EVM prior to handling or using the EVM, including without limitation any warning or restriction notices. The notices contain important safety information related to, for example, temperatures and voltages.

4.3 *Safety-Related Warnings and Restrictions:*

4.3.1 User shall operate the EVM within TI's recommended specifications and environmental considerations stated in the user guide, other available documentation provided by TI, and any other applicable requirements and employ reasonable and customary safeguards. Exceeding the specified performance ratings and specifications (including but not limited to input and output voltage, current, power, and environmental ranges) for the EVM may cause personal injury or death, or property damage. If there are questions concerning performance ratings and specifications, User should contact a TI field representative prior to connecting interface electronics including input power and intended loads. Any loads applied outside of the specified output range may also result in unintended and/or inaccurate operation and/or possible permanent damage to the EVM and/or interface electronics. Please consult the EVM user guide prior to connecting any load to the EVM output. If there is uncertainty as to the load specification, please contact a TI field representative. During normal operation, even with the inputs and outputs kept within the specified allowable ranges, some circuit components may have elevated case temperatures. These components include but are not limited to linear regulators, switching transistors, pass transistors, current sense resistors, and heat sinks, which can be identified using the information in the associated documentation. When working with the EVM, please be aware that the EVM may become very warm.

4.3.2 EVMs are intended solely for use by technically qualified, professional electronics experts who are familiar with the dangers and application risks associated with handling electrical mechanical components, systems, and subsystems. User assumes all responsibility and liability for proper and safe handling and use of the EVM by User or its employees, affiliates, contractors or designees. User assumes all responsibility and liability to ensure that any interfaces (electronic and/or mechanical) between the EVM and any human body are designed with suitable isolation and means to safely limit accessible leakage currents to minimize the risk of electrical shock hazard. User assumes all responsibility and liability for any improper or unsafe handling or use of the EVM by User or its employees, affiliates, contractors or designees.

4.4 User assumes all responsibility and liability to determine whether the EVM is subject to any applicable international, federal, state, or local laws and regulations related to User's handling and use of the EVM and, if applicable, User assumes all responsibility and liability for compliance in all respects with such laws and regulations. User assumes all responsibility and liability for proper disposal and recycling of the EVM consistent with all applicable international, federal, state, and local requirements.

5. *Accuracy of Information:* To the extent TI provides information on the availability and function of EVMs, TI attempts to be as accurate as possible. However, TI does not warrant the accuracy of EVM descriptions, EVM availability or other information on its websites as accurate, complete, reliable, current, or error-free.

6. *Disclaimers:*

6.1 EXCEPT AS SET FORTH ABOVE, EVMS AND ANY MATERIALS PROVIDED WITH THE EVM (INCLUDING, BUT NOT LIMITED TO, REFERENCE DESIGNS AND THE DESIGN OF THE EVM ITSELF) ARE PROVIDED "AS IS" AND "WITH ALL FAULTS." TI DISCLAIMS ALL OTHER WARRANTIES, EXPRESS OR IMPLIED, REGARDING SUCH ITEMS, INCLUDING BUT NOT LIMITED TO ANY EPIDEMIC FAILURE WARRANTY OR IMPLIED WARRANTIES OF MERCHANTABILITY OR FITNESS FOR A PARTICULAR PURPOSE OR NON-INFRINGEMENT OF ANY THIRD PARTY PATENTS, COPYRIGHTS, TRADE SECRETS OR OTHER INTELLECTUAL PROPERTY RIGHTS.

6.2 EXCEPT FOR THE LIMITED RIGHT TO USE THE EVM SET FORTH HEREIN, NOTHING IN THESE TERMS SHALL BE CONSTRUED AS GRANTING OR CONFERRING ANY RIGHTS BY LICENSE, PATENT, OR ANY OTHER INDUSTRIAL OR INTELLECTUAL PROPERTY RIGHT OF TI, ITS SUPPLIERS/LICENSORS OR ANY OTHER THIRD PARTY, TO USE THE EVM IN ANY FINISHED END-USER OR READY-TO-USE FINAL PRODUCT, OR FOR ANY INVENTION, DISCOVERY OR IMPROVEMENT, REGARDLESS OF WHEN MADE, CONCEIVED OR ACQUIRED.

7. *USER'S INDEMNITY OBLIGATIONS AND REPRESENTATIONS.* USER WILL DEFEND, INDEMNIFY AND HOLD TI, ITS LICENSORS AND THEIR REPRESENTATIVES HARMLESS FROM AND AGAINST ANY AND ALL CLAIMS, DAMAGES, LOSSES, EXPENSES, COSTS AND LIABILITIES (COLLECTIVELY, "CLAIMS") ARISING OUT OF OR IN CONNECTION WITH ANY HANDLING OR USE OF THE EVM THAT IS NOT IN ACCORDANCE WITH THESE TERMS. THIS OBLIGATION SHALL APPLY WHETHER CLAIMS ARISE UNDER STATUTE, REGULATION, OR THE LAW OF TORT, CONTRACT OR ANY OTHER LEGAL THEORY, AND EVEN IF THE EVM FAILS TO PERFORM AS DESCRIBED OR EXPECTED.

8. *Limitations on Damages and Liability:*

8.1 *General Limitations.* IN NO EVENT SHALL TI BE LIABLE FOR ANY SPECIAL, COLLATERAL, INDIRECT, PUNITIVE, INCIDENTAL, CONSEQUENTIAL, OR EXEMPLARY DAMAGES IN CONNECTION WITH OR ARISING OUT OF THESE TERMS OR THE USE OF THE EVMS , REGARDLESS OF WHETHER TI HAS BEEN ADVISED OF THE POSSIBILITY OF SUCH DAMAGES. EXCLUDED DAMAGES INCLUDE, BUT ARE NOT LIMITED TO, COST OF REMOVAL OR REINSTALLATION, ANCILLARY COSTS TO THE PROCUREMENT OF SUBSTITUTE GOODS OR SERVICES, RETESTING, OUTSIDE COMPUTER TIME, LABOR COSTS, LOSS OF GOODWILL, LOSS OF PROFITS, LOSS OF SAVINGS, LOSS OF USE, LOSS OF DATA, OR BUSINESS INTERRUPTION. NO CLAIM, SUIT OR ACTION SHALL BE BROUGHT AGAINST TI MORE THAN TWELVE (12) MONTHS AFTER THE EVENT THAT GAVE RISE TO THE CAUSE OF ACTION HAS OCCURRED.

8.2 *Specific Limitations.* IN NO EVENT SHALL TI'S AGGREGATE LIABILITY FROM ANY USE OF AN EVM PROVIDED HEREUNDER, INCLUDING FROM ANY WARRANTY, INDEMNITY OR OTHER OBLIGATION ARISING OUT OF OR IN CONNECTION WITH THESE TERMS, , EXCEED THE TOTAL AMOUNT PAID TO TI BY USER FOR THE PARTICULAR EVM(S) AT ISSUE DURING THE PRIOR TWELVE (12) MONTHS WITH RESPECT TO WHICH LOSSES OR DAMAGES ARE CLAIMED. THE EXISTENCE OF MORE THAN ONE CLAIM SHALL NOT ENLARGE OR EXTEND THIS LIMIT.

9. *Return Policy.* Except as otherwise provided, TI does not offer any refunds, returns, or exchanges. Furthermore, no return of EVM(s) will be accepted if the package has been opened and no return of the EVM(s) will be accepted if they are damaged or otherwise not in a resalable condition. If User feels it has been incorrectly charged for the EVM(s) it ordered or that delivery violates the applicable order, User should contact TI. All refunds will be made in full within thirty (30) working days from the return of the components(s), excluding any postage or packaging costs.

10. *Governing Law:* These terms and conditions shall be governed by and interpreted in accordance with the laws of the State of Texas, without reference to conflict-of-laws principles. User agrees that non-exclusive jurisdiction for any dispute arising out of or relating to these terms and conditions lies within courts located in the State of Texas and consents to venue in Dallas County, Texas. Notwithstanding the foregoing, any judgment may be enforced in any United States or foreign court, and TI may seek injunctive relief in any United States or foreign court.

IMPORTANT NOTICE FOR TI DESIGN INFORMATION AND RESOURCES

Texas Instruments Incorporated ("TI") technical, application or other design advice, services or information, including, but not limited to, reference designs and materials relating to evaluation modules, (collectively, "TI Resources") are intended to assist designers who are developing applications that incorporate TI products; by downloading, accessing or using any particular TI Resource in any way, you (individually or, if you are acting on behalf of a company, your company) agree to use it solely for this purpose and subject to the terms of this Notice.

TI's provision of TI Resources does not expand or otherwise alter TI's applicable published warranties or warranty disclaimers for TI products, and no additional obligations or liabilities arise from TI providing such TI Resources. TI reserves the right to make corrections, enhancements, improvements and other changes to its TI Resources.

You understand and agree that you remain responsible for using your independent analysis, evaluation and judgment in designing your applications and that you have full and exclusive responsibility to assure the safety of your applications and compliance of your applications (and of all TI products used in or for your applications) with all applicable regulations, laws and other applicable requirements. You represent that, with respect to your applications, you have all the necessary expertise to create and implement safeguards that (1) anticipate dangerous consequences of failures, (2) monitor failures and their consequences, and (3) lessen the likelihood of failures that might cause harm and take appropriate actions. You agree that prior to using or distributing any applications that include TI products, you will thoroughly test such applications and the functionality of such TI products as used in such applications. TI has not conducted any testing other than that specifically described in the published documentation for a particular TI Resource.

You are authorized to use, copy and modify any individual TI Resource only in connection with the development of applications that include the TI product(s) identified in such TI Resource. NO OTHER LICENSE, EXPRESS OR IMPLIED, BY ESTOPPEL OR OTHERWISE TO ANY OTHER TI INTELLECTUAL PROPERTY RIGHT, AND NO LICENSE TO ANY TECHNOLOGY OR INTELLECTUAL PROPERTY RIGHT OF TI OR ANY THIRD PARTY IS GRANTED HEREIN, including but not limited to any patent right, copyright, mask work right, or other intellectual property right relating to any combination, machine, or process in which TI products or services are used. Information regarding or referencing third-party products or services does not constitute a license to use such products or services, or a warranty or endorsement thereof. Use of TI Resources may require a license from a third party under the patents or other intellectual property of the third party, or a license from TI under the patents or other intellectual property of TI.

TI RESOURCES ARE PROVIDED "AS IS" AND WITH ALL FAULTS. TI DISCLAIMS ALL OTHER WARRANTIES OR REPRESENTATIONS, EXPRESS OR IMPLIED, REGARDING TI RESOURCES OR USE THEREOF, INCLUDING BUT NOT LIMITED TO ACCURACY OR COMPLETENESS, TITLE, ANY EPIDEMIC FAILURE WARRANTY AND ANY IMPLIED WARRANTIES OF MERCHANTABILITY, FITNESS FOR A PARTICULAR PURPOSE, AND NON-INFRINGEMENT OF ANY THIRD PARTY INTELLECTUAL PROPERTY RIGHTS.

TI SHALL NOT BE LIABLE FOR AND SHALL NOT DEFEND OR INDEMNIFY YOU AGAINST ANY CLAIM, INCLUDING BUT NOT LIMITED TO ANY INFRINGEMENT CLAIM THAT RELATES TO OR IS BASED ON ANY COMBINATION OF PRODUCTS EVEN IF DESCRIBED IN TI RESOURCES OR OTHERWISE. IN NO EVENT SHALL TI BE LIABLE FOR ANY ACTUAL, DIRECT, SPECIAL, COLLATERAL, INDIRECT, PUNITIVE, INCIDENTAL, CONSEQUENTIAL OR EXEMPLARY DAMAGES IN CONNECTION WITH OR ARISING OUT OF TI RESOURCES OR USE THEREOF, AND REGARDLESS OF WHETHER TI HAS BEEN ADVISED OF THE POSSIBILITY OF SUCH DAMAGES.

You agree to fully indemnify TI and its representatives against any damages, costs, losses, and/or liabilities arising out of your non-compliance with the terms and provisions of this Notice.

This Notice applies to TI Resources. Additional terms apply to the use and purchase of certain types of materials, TI products and services. These include; without limitation, TI's standard terms for semiconductor products (<http://www.ti.com/sc/docs/stdterms.htm>), [evaluation modules](#), and [samples](http://www.ti.com/sc/docs/sampterm.htm) (<http://www.ti.com/sc/docs/sampterm.htm>).

Mailing Address: Texas Instruments, Post Office Box 655303, Dallas, Texas 75265
Copyright © 2018, Texas Instruments Incorporated

Looking for pricing, stock, or lifecycle information?

Click below to explore more details on WIN SOURCE:

 [View PGA305EVM-034](#) on WIN SOURCE

 [Texas Instruments](#) Information

Optimize Your Supply Chain with WIN SOURCE Solutions

-  Global Sourcing Solution
-  Obsolete Management
-  Cost Control Management
-  Shortage Management
-  Alternative Solution
-  Excess Inventory Management