



**THE DATASHEET OF  
MAX5825AAUP+**



# MAX5823/MAX5824/ MAX5825

# Ultra-Small, Octal Channel, 8-/10-/12-Bit Buffered Output DACs with Internal Reference and I<sup>2</sup>C Interface

## General Description

The MAX5823/MAX5824/MAX5825 8-channel, low-power, 8-/10-/12-bit, voltage-output digital-to-analog converters (DACs) include output buffers and an internal 3ppm/°C reference that is selectable to be 2.048V, 2.500V, or 4.096V. The MAX5823/MAX5824/MAX5825 accept a wide supply voltage range of 2.7V to 5.5V with extremely low power (6mW) consumption to accommodate most low-voltage applications. A precision external reference input allows rail-to-rail operation and presents a 100kΩ (typ) load to an external reference.

The MAX5823/MAX5824/MAX5825 have an I<sup>2</sup>C-compatible, 2-wire interface that operates at clock rates up to 400kHz. The DAC output is buffered and has a low supply current of less than 250μA per channel and a low offset error of ±0.5mV (typ). On power-up, the MAX5823/MAX5824/MAX5825 reset the DAC outputs to zero or mid-scale based on the status of M/Z logic input, providing flexibility for a variety of control applications. The internal reference is initially powered down to allow use of an external reference. The MAX5823/MAX5824/MAX5825 allow simultaneous output updates using software LOAD commands or the hardware load DAC logic input (LDAC).

The MAX5823/MAX5824/MAX5825 feature a watchdog function which can be enabled to monitor the I/O interface for activity and integrity.

A clear logic input (CLR) allows the contents of the CODE and the DAC registers to be cleared asynchronously and simultaneously sets the DAC outputs to the programmable default value. The MAX5823/MAX5824/MAX5825 are available in a 20-pin TSSOP and an ultra-small, 20-bump WLP package and are specified over the -40°C to +125°C temperature range.

## Applications

- Programmable Voltage and Current Sources
- Gain and Offset Adjustment
- Automatic Tuning and Optical Control
- Power Amplifier Control and Biasing
- Process Control and Servo Loops
- Portable Instrumentation

*Ordering Information appears at end of data sheet.*

## Benefits and Features

- Eight High-Accuracy DAC Channels
  - 12-Bit Accuracy Without Adjustment
  - ±1 LSB INL Buffered Voltage Output
  - Guaranteed Monotonic Over All Operating Conditions
  - Independent Mode Settings for Each DAC
- Three Precision Selectable Internal References
  - 2.048V, 2.500V, or 4.096V
- Internal Output Buffer
  - Rail-to-Rail Operation with External Reference
  - 4.5μs Settling Time
  - Outputs Directly Drive 2kΩ Loads
- Small 6.5mm x 4.4mm 20-Pin TSSOP or Ultra-Small 2.5mm x 2.3mm 20-Bump WLP Package
- Wide 2.7V to 5.5V Supply Range
- Separate 1.8V to 5.5V V<sub>DDIO</sub> Power-Supply Input
- Fast 400kHz I<sup>2</sup>C-Compatible, 2-Wire Serial Interface
- Pin-Selectable Power-On-Reset to Zero-Scale or Midscale DAC Output
- $\overline{\text{LDAC}}$  and  $\overline{\text{CLR}}$  For Asynchronous DAC Control
- Three Software-Selectable Power-Down Output Impedances
  - 1kΩ, 100kΩ, or High Impedance

## Functional Diagram

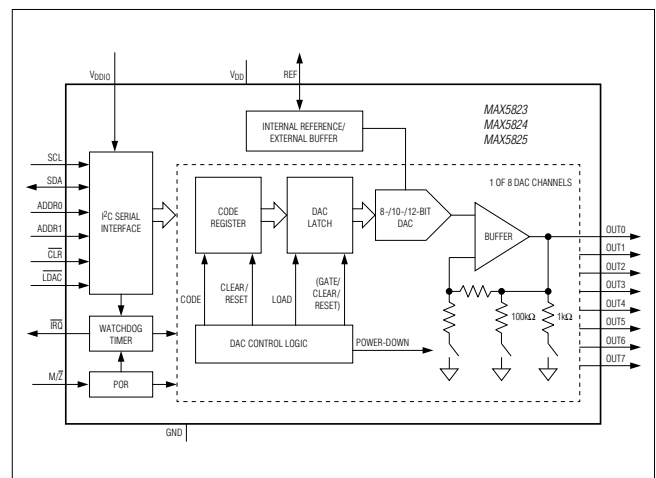

MAX5823/MAX5824/  
MAX5825

Ultra-Small, Octal Channel, 8-/10-/12-Bit  
Buffered Output DACs with Internal  
Reference and I<sup>2</sup>C Interface

**Absolute Maximum Ratings**

V<sub>DD</sub>, V<sub>DDIO</sub> to GND .....-0.3V to +6V  
 OUT<sub>-</sub>, REF to GND....0.3V to the lower of (V<sub>DD</sub> + 0.3V) and +6V  
 SCL, SDA, I<sup>2</sup>C, M/Z, LDAC, CLR to GND .....-0.3V to +6V  
 ADDR<sub>-</sub> to GND.....-0.3V to the lower of  
 (V<sub>DDIO</sub> + 0.3V) and +6V  
 Continuous Power Dissipation (T<sub>A</sub> = +70°C)  
 TSSOP (derate at 13.6mW/°C above 70°C)..... 1084mW  
 WLP (derate at 21.3mW/°C above 70°C)..... 1700mW

Maximum Continuous Current into Any Pin ..... ±50mA  
 Operating Temperature..... -40°C to +125°C  
 Storage Temperature ..... -65°C to +150°C  
 Lead Temperature (TSSOP only)(soldering, 10s).....+300°C  
 Soldering Temperature (reflow) ..... +260°C

Stresses beyond those listed under "Absolute Maximum Ratings" may cause permanent damage to the device. These are stress ratings only, and functional operation of the device at these or any other conditions beyond those indicated in the operational sections of the specifications is not implied. Exposure to absolute maximum rating conditions for extended periods may affect device reliability.

**Package Thermal Characteristics (Note 1)**

TSSOP  
 Junction-to-Ambient Thermal Resistance (θ<sub>JA</sub>) ..... 73.8°C/W  
 Junction-to-Case Thermal Resistance (θ<sub>JC</sub>) ..... 20°C/W

WLP  
 Junction-to-Ambient Thermal Resistance (θ<sub>JA</sub>)  
 (Note 2) ..... 47°C/W

**Note 1:** Package thermal resistances were obtained using the method described in JEDEC specification JESD51-7, using a four-layer board. For detailed information on package thermal considerations, refer to [www.maximintegrated.com/thermal-tutorial](http://www.maximintegrated.com/thermal-tutorial).

**Note 2:** Visit [www.maximintegrated.com/app-notes/index.mvp/id/1891](http://www.maximintegrated.com/app-notes/index.mvp/id/1891) for information about the thermal performance of WLP packaging.

**Electrical Characteristics**

(V<sub>DD</sub> = 2.7V to 5.5V, V<sub>DDIO</sub> = 1.8V to 5.5V, V<sub>GND</sub> = 0V, C<sub>L</sub> = 200pF, R<sub>L</sub> = 2kΩ, T<sub>A</sub> = -40°C to +125°C, unless otherwise noted.)  
 (Note 3)

PARAMETER	SYMBOL	CONDITIONS	MIN	TYP	MAX	UNITS
<b>DC PERFORMANCE (Note 4)</b>						
Resolution and Monotonicity	N	MAX5823	8			Bits
		MAX5824	10			
		MAX5825	12			
Integral Nonlinearity (Note 5)	INL	MAX5823	-0.25	±0.05	+0.25	LSB
		MAX5824	-0.5	±0.2	+0.5	
		MAX5825	-1	±0.5	+1	
Differential Nonlinearity (Note 5)	DNL	MAX5823	-0.25	±0.05	+0.25	LSB
		MAX5824	-0.5	±0.1	+0.5	
		MAX5825	-1	±0.2	+1	
Offset Error (Note 6)	OE		-5	±0.5	+5	mV
Offset Error Drift				±10		µV/°C
Gain Error (Note 6)	GE		-1.0	±0.1	+1.0	%FS
Gain Temperature Coefficient		With respect to V <sub>REF</sub>		±3.0		ppm of FS/°C
Zero-Scale Error			0		+10	mV
Full-Scale Error		With respect to V <sub>REF</sub>	-0.5		+0.5	%FS

**Electrical Characteristics (continued)**

(V<sub>DD</sub> = 2.7V to 5.5V, V<sub>DDIO</sub> = 1.8V to 5.5V, V<sub>GND</sub> = 0V, C<sub>L</sub> = 200pF, R<sub>L</sub> = 2kΩ, T<sub>A</sub> = -40°C to +125°C, unless otherwise noted.)  
(Note 3)

PARAMETER	SYMBOL	CONDITIONS	MIN	TYP	MAX	UNITS
<b>DAC OUTPUT CHARACTERISTICS</b>						
Output Voltage Range (Note 7)		No load	0		V <sub>DD</sub>	V
		2kΩ load to GND	0		V <sub>DD</sub> - 0.2	
		2kΩ load to V <sub>DD</sub>	0.2		V <sub>DD</sub>	
Load Regulation		V <sub>OUT</sub> = V <sub>FS</sub> /2	V <sub>DD</sub> = 3V ±10%,  I <sub>OUT</sub>   ≤ 5mA	300		μV/mA
			V <sub>DD</sub> = 5V ±10%,  I <sub>OUT</sub>   ≤ 10mA	300		
DC Output Impedance		V <sub>OUT</sub> = V <sub>FS</sub> /2	V <sub>DD</sub> = 3V ±10%,  I <sub>OUT</sub>   ≤ 5mA	0.3		Ω
			V <sub>DD</sub> = 5V ±10%,  I <sub>OUT</sub>   ≤ 10mA	0.3		
Maximum Capacitive Load Handling	C <sub>L</sub>			500		pF
Resistive Load Handling	R <sub>L</sub>		2			kΩ
Short-Circuit Output Current		V <sub>DD</sub> = 5.5V	Sourcing (output shorted to GND)	30		mA
			Sinking (output shorted to V <sub>DD</sub> )	50		
DC Power-Supply Rejection		V <sub>DD</sub> = 3V ±10% or 5V ±10%		100		μV/V
<b>DYNAMIC PERFORMANCE</b>						
Voltage-Output Slew Rate	SR	Positive and negative		1.0		V/μs
Voltage-Output Settling Time		¼ scale to ¾ scale, to ≤ 1 LSB, MAX5823		2.2		μs
		¼ scale to ¾ scale, to ≤ 1 LSB, MAX5824		2.6		
		¼ scale to ¾ scale, to ≤ 1 LSB, MAX5825		4.5		
DAC Glitch Impulse		Major code transition (code x7FF to x800)		7		nV*s
Channel-to-Channel Feedthrough (Note 8)		Internal reference		3.3		nV*s
		External reference		4.07		
Digital Feedthrough		Midscale code, all digital inputs from 0V to V <sub>DDIO</sub>		0.2		nV*s
Power-Up Time		Startup calibration time (Note 9)		200		μs
		From power-down		50		μs

**Electrical Characteristics (continued)**

(V<sub>DD</sub> = 2.7V to 5.5V, V<sub>DDIO</sub> = 1.8V to 5.5V, V<sub>GND</sub> = 0V, C<sub>L</sub> = 200pF, R<sub>L</sub> = 2kΩ, T<sub>A</sub> = -40°C to +125°C, unless otherwise noted.)  
(Note 3)

PARAMETER	SYMBOL	CONDITIONS		MIN	TYP	MAX	UNITS
Output Voltage-Noise Density (DAC Output at Midscale)		External reference	f = 1kHz		90		nV/√Hz
			f = 10kHz		82		
		2.048V internal reference	f = 1kHz		112		
			f = 10kHz		102		
		2.5V internal reference	f = 1kHz		125		
			f = 10kHz		110		
4.096V internal reference	f = 1kHz		160				
	f = 10kHz		145				
Integrated Output Noise (DAC Output at Midscale)		External reference	f = 0.1Hz to 10Hz		12		μV <sub>P-P</sub>
			f = 0.1Hz to 10kHz		76		
			f = 0.1Hz to 300kHz		385		
		2.048V internal reference	f = 0.1Hz to 10Hz		14		
			f = 0.1Hz to 10kHz		91		
			f = 0.1Hz to 300kHz		450		
		2.5V internal reference	f = 0.1Hz to 10Hz		15		
			f = 0.1Hz to 10kHz		99		
			f = 0.1Hz to 300kHz		470		
		4.096V internal reference	f = 0.1Hz to 10Hz		16		
			f = 0.1Hz to 10kHz		124		
			f = 0.1Hz to 300kHz		490		
Output Voltage-Noise Density (DAC Output at Full Scale)		External reference	f = 1kHz		114		nV/√Hz
			f = 10kHz		99		
		2.048V internal reference	f = 1kHz		175		
			f = 10kHz		153		
		2.5V internal reference	f = 1kHz		200		
			f = 10kHz		174		
4.096V internal reference	f = 1kHz		295				
	f = 10kHz		255				
Integrated Output Noise (DAC Output at Full Scale)		External reference	f = 0.1Hz to 10Hz		13		μV <sub>P-P</sub>
			f = 0.1Hz to 10kHz		94		
			f = 0.1Hz to 300kHz		540		
		2.048V internal reference	f = 0.1Hz to 10Hz		19		
			f = 0.1Hz to 10kHz		143		
			f = 0.1Hz to 300kHz		685		
		2.5V internal reference	f = 0.1Hz to 10Hz		21		
			f = 0.1Hz to 10kHz		159		
			f = 0.1Hz to 300kHz		705		
		4.096V internal reference	f = 0.1Hz to 10Hz		26		
			f = 0.1Hz to 10kHz		213		
			f = 0.1Hz to 300kHz		750		

MAX5823/MAX5824/  
MAX5825

Ultra-Small, Octal Channel, 8-/10-/12-Bit  
Buffered Output DACs with Internal  
Reference and I<sup>2</sup>C Interface

Electrical Characteristics (continued)

(V<sub>DD</sub> = 2.7V to 5.5V, V<sub>DDIO</sub> = 1.8V to 5.5V, V<sub>GND</sub> = 0V, C<sub>L</sub> = 200pF, R<sub>L</sub> = 2kΩ, T<sub>A</sub> = -40°C to +125°C, unless otherwise noted.)  
(Note 3)

PARAMETER	SYMBOL	CONDITIONS	MIN	TYP	MAX	UNITS	
<b>REFERENCE INPUT</b>							
Reference Input Range	V <sub>REF</sub>		1.24		V <sub>DD</sub>	V	
Reference Input Current	I <sub>REF</sub>	V <sub>REF</sub> = V <sub>DD</sub> = 5.5V		55	74	μA	
Reference Input Impedance	R <sub>REF</sub>		75	100		kΩ	
<b>REFERENCE OUTPUT</b>							
Reference Output Voltage	V <sub>REF</sub>	V <sub>REF</sub> = 2.048V, T <sub>A</sub> = +25°C	2.043	2.048	2.053	V	
		V <sub>REF</sub> = 2.5V, T <sub>A</sub> = +25°C	2.494	2.500	2.506		
		V <sub>REF</sub> = 4.096V, T <sub>A</sub> = +25°C	4.086	4.096	4.106		
Reference Temperature Coefficient (Note 10)		MAX5825A		±3	±10	ppm/°C	
		MAX5823/MAX5824/MAX5825B		±10	±25		
Reference Drive Capacity		External load		25		kΩ	
Reference Capacitive Load Handling				200		pF	
Reference Load Regulation		I <sub>SOURCE</sub> = 0 to 500μA		2		mV/mA	
Reference Line Regulation				0.05		mV/V	
<b>POWER REQUIREMENTS</b>							
Supply Voltage	V <sub>DD</sub>	V <sub>REF</sub> = 4.096V	4.5		5.5	V	
		All other options	2.7		5.5		
I/O Supply Voltage	V <sub>DDIO</sub>		1.8		5.5	V	
Supply Current (Note 11)	I <sub>DD</sub>	Internal reference	V <sub>REF</sub> = 2.048V		1.6	2	mA
			V <sub>REF</sub> = 2.5V		1.7	2.1	
			V <sub>REF</sub> = 4.096V		2.0	2.5	
		External reference	V <sub>REF</sub> = 3V		1.6	2.0	
			V <sub>REF</sub> = 5V		1.9	2.5	
Power-Down Mode Supply Current	I <sub>PD</sub>	All DACs off, internal reference ON		140		μA	
		All DACs off, internal reference OFF, T <sub>A</sub> = -40°C to +85°C		0.7	2		
		All DACs off, internal reference OFF, T <sub>A</sub> = +125°C		2	4		
Digital Supply Current	I <sub>DDIO</sub>	Static logic inputs, all outputs unloaded			1	μA	
<b>DIGITAL INPUT CHARACTERISTICS (SCL, SDA, ADDR0, ADDR1, LDAC, CLR, M<math>\bar{Z}</math>)</b>							
Input High Voltage (Note 11)	V <sub>IH</sub>	(All inputs except M $\bar{Z}$ )	2.2V < V <sub>DDIO</sub> < 5.5V		0.7 × V <sub>DDIO</sub>	V	
			1.8V < V <sub>DDIO</sub> < 2.2V		0.8 × V <sub>DDIO</sub>	V	
			2.7V < V <sub>DD</sub> < 5.5V (for M $\bar{Z}$ )		0.7 × V <sub>DD</sub>		

MAX5823/MAX5824/  
MAX5825

Ultra-Small, Octal Channel, 8-/10-/12-Bit  
Buffered Output DACs with Internal  
Reference and I<sup>2</sup>C Interface

Electrical Characteristics (continued)

(V<sub>DD</sub> = 2.7V to 5.5V, V<sub>DDIO</sub> = 1.8V to 5.5V, V<sub>GND</sub> = 0V, C<sub>L</sub> = 200pF, R<sub>L</sub> = 2kΩ, T<sub>A</sub> = -40°C to +125°C, unless otherwise noted.)  
(Note 3)

PARAMETER	SYMBOL	CONDITIONS	MIN	TYP	MAX	UNITS
Input Low Voltage (Note 11)	V <sub>IL</sub>	(All inputs except M/ $\bar{Z}$ )	2.2V < V <sub>DDIO</sub> < 5.5V		0.3 x V <sub>DDIO</sub>	V
			1.8V < V <sub>DDIO</sub> < 2.2V		0.2 x V <sub>DDIO</sub>	V
			2.7V < V <sub>DD</sub> < 5.5V (for M/ $\bar{Z}$ )		0.3 x V <sub>DD</sub>	
Input Leakage Current	I <sub>IN</sub>	V <sub>IN</sub> = 0V or V <sub>DDIO</sub> , all inputs except M/ $\bar{Z}$ (Note 11)	±0.1	±1	±1	μA
		V <sub>IN</sub> = 0V or V <sub>DD</sub> , for M/ $\bar{Z}$ (Note 11)				
Input Capacitance (Note 10)	C <sub>IN</sub>				10	pF
Hysteresis Voltage	V <sub>H</sub>			0.15		V
ADDR_ Pullup/Pulldown Strength	R <sub>PU</sub> , R <sub>PD</sub>	(Note 12)	30	50	90	kΩ
<b>DIGITAL OUTPUT (SDA, <math>\overline{\text{IRQ}}</math>)</b>						
Output Low Voltage	V <sub>OL</sub>	I <sub>SINK</sub> = 3mA			0.2	V
Output Inactive Leakage	I <sub>OFF</sub>	$\overline{\text{IRQ}}$ only, see I <sub>IN</sub> for SDA	±0.1	±1	±1	μA
Output Inactive Capacitance	C <sub>OFF</sub>	$\overline{\text{IRQ}}$ only, see C <sub>IN</sub> for SDA			10	pF
<b>WATCHDOG TIMER CHARACTERISTICS</b>						
Watchdog Timer Period	t <sub>WDOSC</sub>	V <sub>DD</sub> = 3V, T <sub>A</sub> = +25°C	0.95	1	1.05	ms
Watchdog Timer Period Supply Drift		V <sub>DD</sub> = 2.7V to 5.5V, T <sub>A</sub> = +25°C		0.6		%/V
Watchdog Timer Period Temperature Drift		V <sub>DD</sub> = 3V		0.0375		%/°C
<b>I<sup>2</sup>C TIMING CHARACTERISTICS (SCL, SDA, <math>\overline{\text{LDAC}}</math>, <math>\overline{\text{CLR}}</math>)</b>						
SCL Clock Frequency	f <sub>SCL</sub>				400	kHz
Bus Free Time Between a STOP and a START Condition	t <sub>BUF</sub>		1.3			μs
Hold Time Repeated for a START Condition	t <sub>HD;STA</sub>		0.6			μs
SCL Pulse Width Low	t <sub>LOW</sub>		1.3			μs
SCL Pulse Width High	t <sub>HIGH</sub>		0.6			μs
Setup Time for Repeated START Condition	t <sub>SU;STA</sub>		0.6			μs
Data Hold Time	t <sub>HD;DAT</sub>		0		900	ns
Data Setup Time	t <sub>SU;DAT</sub>		100			ns
SDA and SCL Receiving Rise Time	t <sub>R</sub>		20 + C <sub>B</sub> /10		300	ns
SDA and SCL Receiving Fall Time	t <sub>F</sub>		20 + C <sub>B</sub> /10		300	ns

**Electrical Characteristics (continued)**

(V<sub>DD</sub> = 2.7V to 5.5V, V<sub>DDIO</sub> = 1.8V to 5.5V, V<sub>GND</sub> = 0V, C<sub>L</sub> = 200pF, R<sub>L</sub> = 2kΩ, T<sub>A</sub> = -40°C to +125°C, unless otherwise noted.)  
(Note 3)

PARAMETER	SYMBOL	CONDITIONS	MIN	TYP	MAX	UNITS
SDA Transmitting Fall Time	t <sub>F</sub>		20 + C <sub>B</sub> /10		250	ns
Setup Time for STOP Condition	t <sub>SU;STO</sub>		0.6			μs
Bus Capacitance Allowed	C <sub>B</sub>	V <sub>DD</sub> = 2.7V to 5.5V	10		400	pF
Pulse Width of Suppressed Spike	t <sub>SP</sub>			50		ns
CL <sub>R</sub> Removal Time Prior to a Recognized START	t <sub>CLRSTA</sub>		100			ns
CL <sub>R</sub> Pulse Width Low	t <sub>CLPW</sub>		20			ns
LDAC Pulse Width Low	t <sub>LDPW</sub>		20			ns
LDAC Fall to SCLK Rise Hold	t <sub>LDH</sub>		400			ns

**Note 3:** Electrical specifications are production tested at T<sub>A</sub> = +25°C. Specifications over the entire operating temperature range are guaranteed by design and characterization. Typical specifications are at T<sub>A</sub> = +25°C.

**Note 4:** DC performance is tested without load, V<sub>REF</sub> = V<sub>DD</sub>.

**Note 5:** Linearity is tested with unloaded outputs to within 20mV of GND and V<sub>DD</sub>.

**Note 6:** Offset and gain calculated from measurements made with V<sub>REF</sub> = V<sub>DD</sub> at code 30 and 4065 for MAX5825, code 8 and 1016 for MAX5824, and code 2 and 254 for MAX5823.

**Note 7:** Subject to zero- and full-scale error limits and V<sub>REF</sub> settings.

**Note 8:** Measured with all other DAC outputs at midscale with one channel transitioning 0 to full scale.

**Note 9:** On power-up, the device initiates an internal 200μs (typ) calibration sequence. All commands issued during this time will be ignored.

**Note 10:** Guaranteed by design.

**Note 11:** All channels active at V<sub>FS</sub>, unloaded. Static logic inputs with V<sub>IL</sub> = V<sub>GND</sub> and V<sub>IH</sub> = V<sub>DDIO</sub> for all inputs.

**Note 12:** Unconnected conditions on the ADDR<sub>n</sub> inputs are sensed through a resistive pullup and pulldown operation; for proper operation, ADDR<sub>n</sub> inputs must be connected to V<sub>DDIO</sub>, GND, or left unconnected with minimal capacitance.

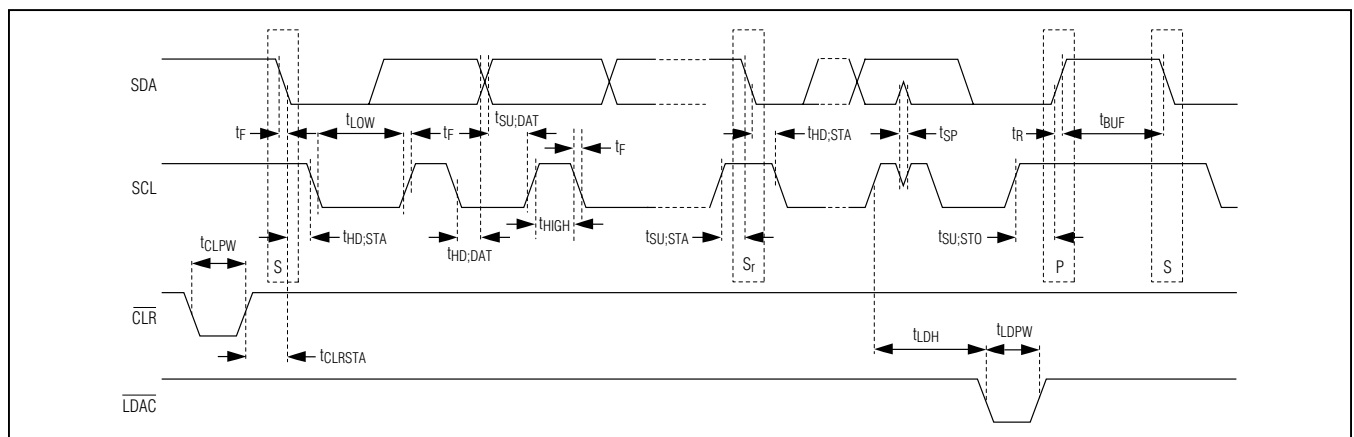
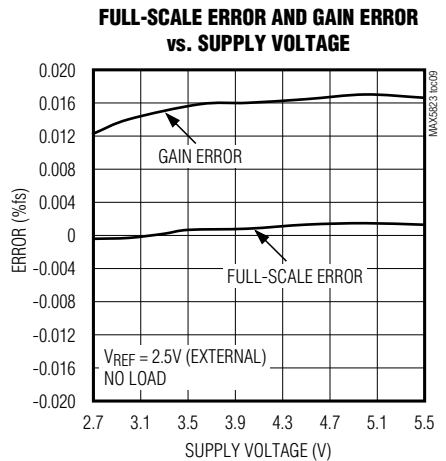
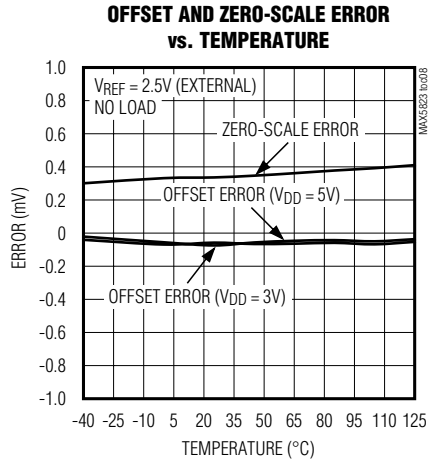
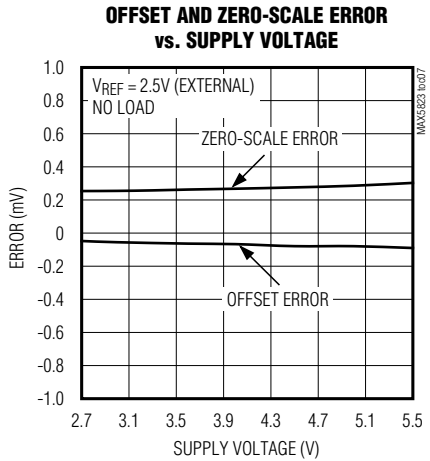
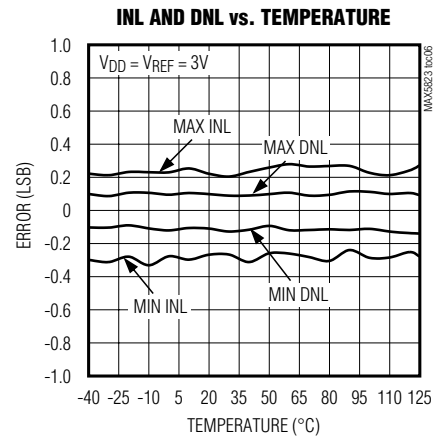
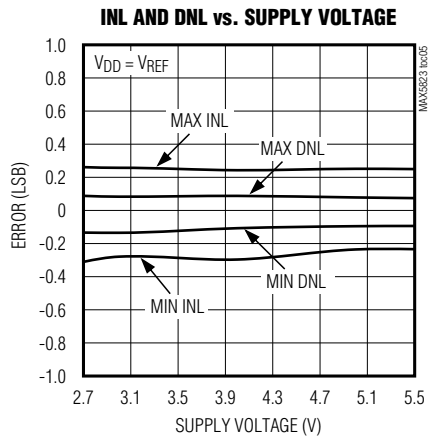
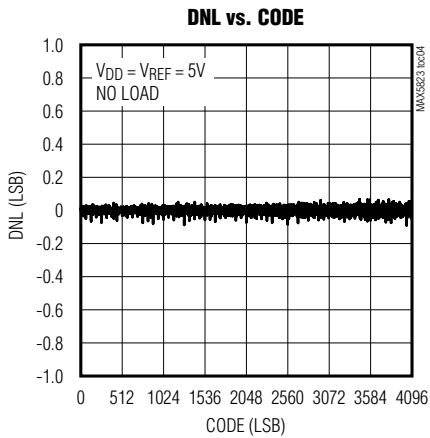
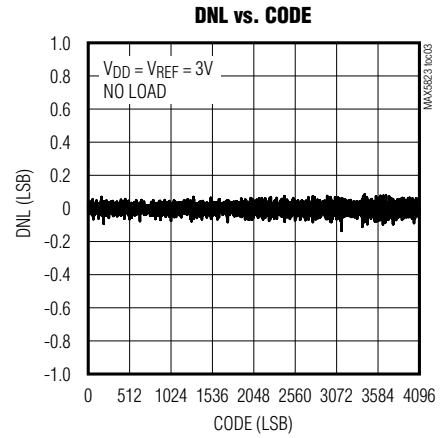
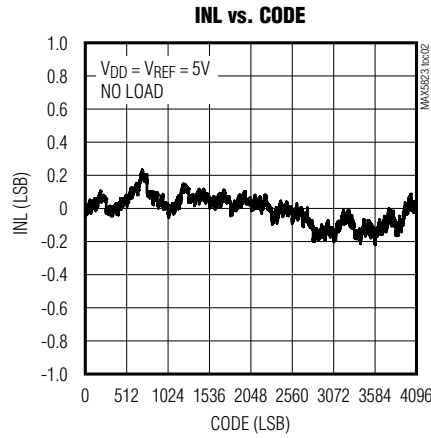
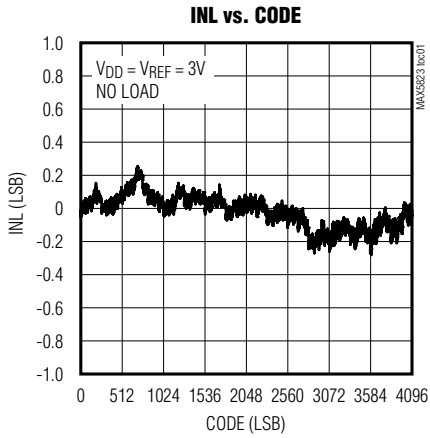

Figure 1. I<sup>2</sup>C Serial Interface Timing Diagram

Typical Operating Characteristics

(MAX5825, 12-bit performance, T<sub>A</sub> = +25°C, unless otherwise noted.)



Typical Operating Characteristics (continued)

(MAX5825, 12-bit performance, T<sub>A</sub> = +25°C, unless otherwise noted.)

**FULL-SCALE ERROR AND GAIN ERROR vs. TEMPERATURE**

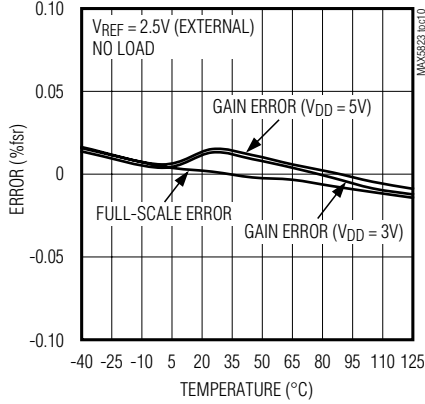

**SUPPLY CURRENT vs. TEMPERATURE**

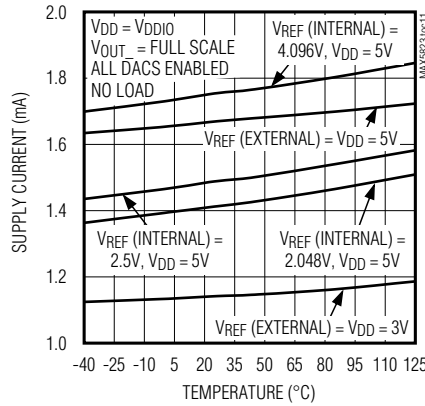

**SUPPLY CURRENT vs. SUPPLY VOLTAGE**

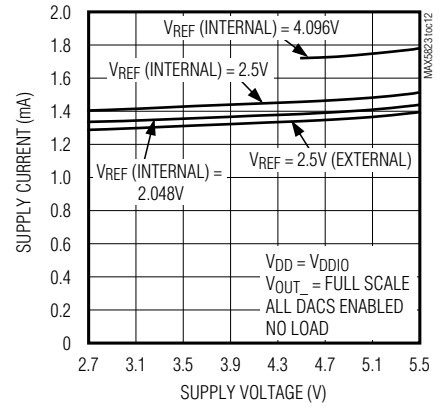

**POWER-DOWN MODE SUPPLY CURRENT vs. SUPPLY VOLTAGE**

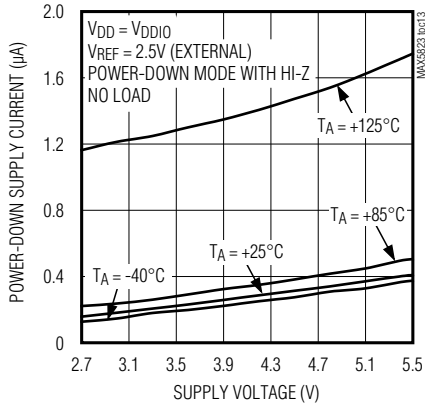

**I<sub>VDD</sub> vs. CODE**

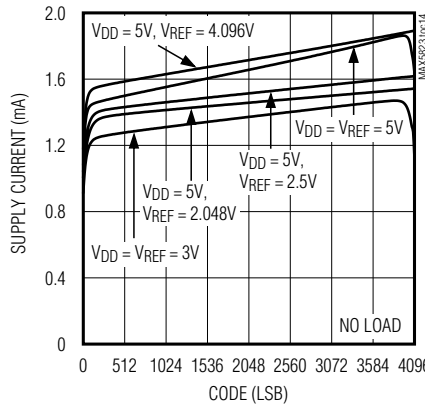

**I<sub>REF</sub> (EXTERNAL) vs. CODE**

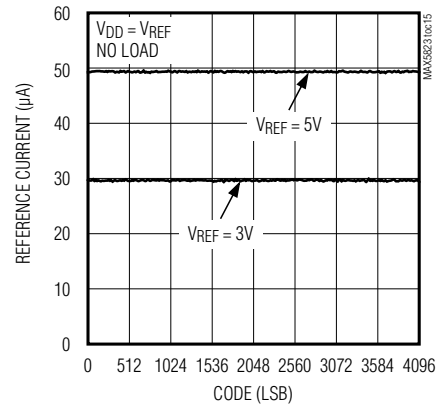

**SETTLING TO ±1 LSB (V<sub>DD</sub> = V<sub>REF</sub> = 5V, R<sub>L</sub> = 2kΩ, C<sub>L</sub> = 200pF)**

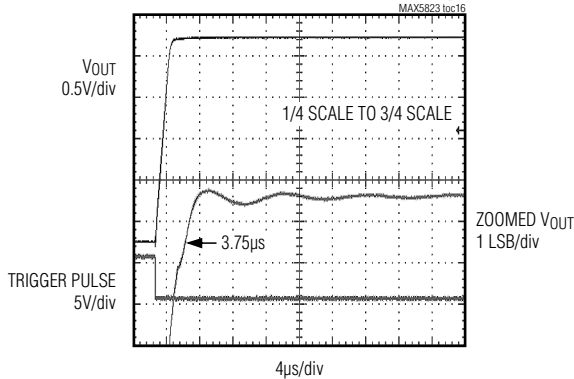

**SETTLING TO ±1 LSB (V<sub>DD</sub> = V<sub>REF</sub> = 5V, R<sub>L</sub> = 2kΩ, C<sub>L</sub> = 200pF)**

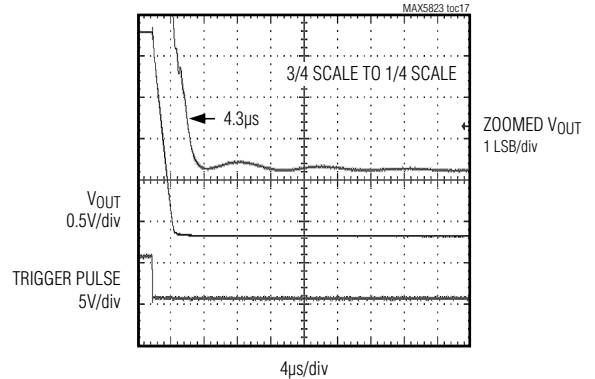

Typical Operating Characteristics (continued)

(MAX5825, 12-bit performance, T<sub>A</sub> = +25°C, unless otherwise noted.)

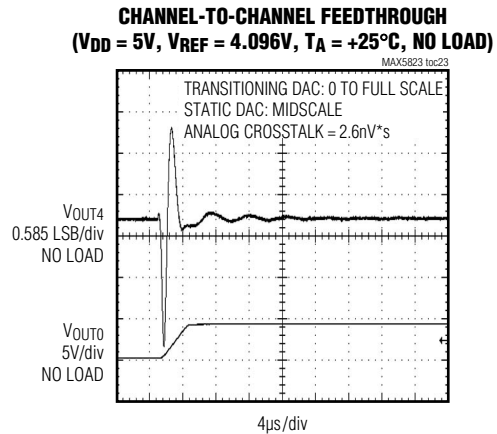
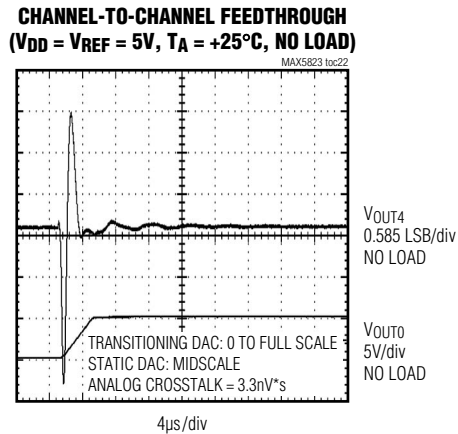
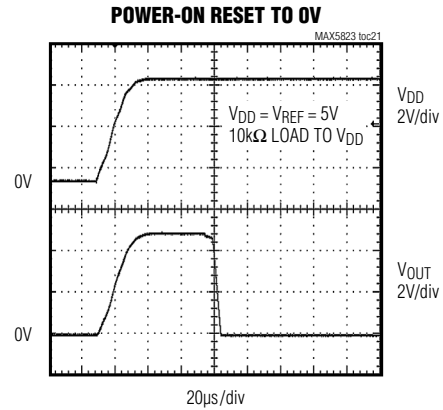
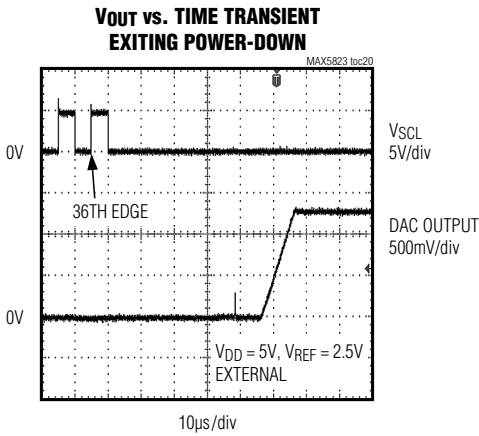
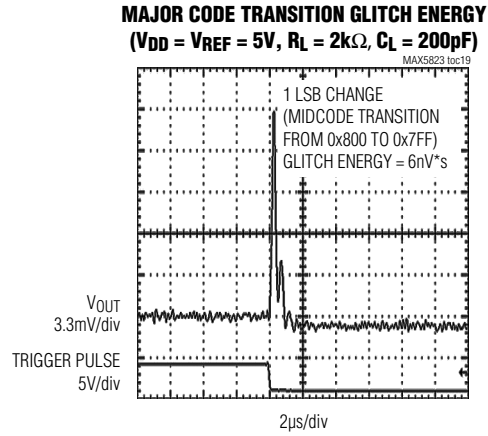
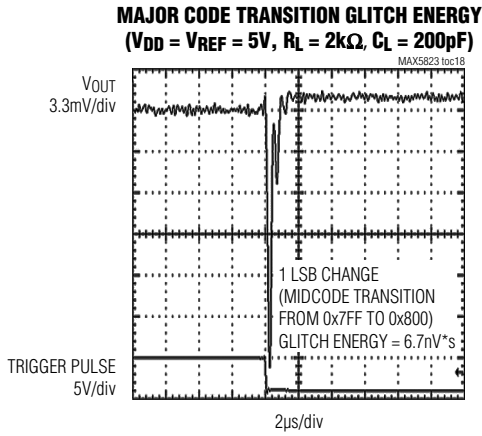

Typical Operating Characteristics (continued)

(MAX5825, 12-bit performance, T<sub>A</sub> = +25°C, unless otherwise noted.)

**CHANNEL-TO-CHANNEL FEEDTHROUGH**  
(V<sub>DD</sub> = V<sub>REF</sub> = 5V, T<sub>A</sub> = +25°C,  
R<sub>L</sub> = 2kΩ, C<sub>L</sub> = 200pF)

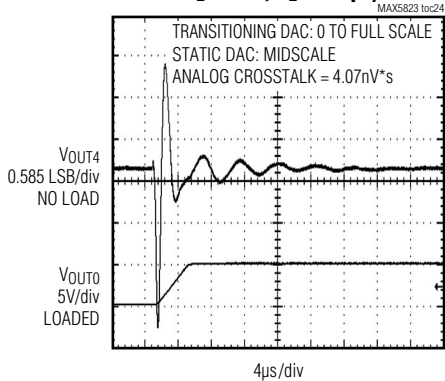

**CHANNEL-TO-CHANNEL FEEDTHROUGH**  
(V<sub>DD</sub> = 5V, V<sub>REF</sub> = 4.096V (INTERNAL),  
T<sub>A</sub> = +25°C, R<sub>L</sub> = 2kΩ, C<sub>L</sub> = 200pF)

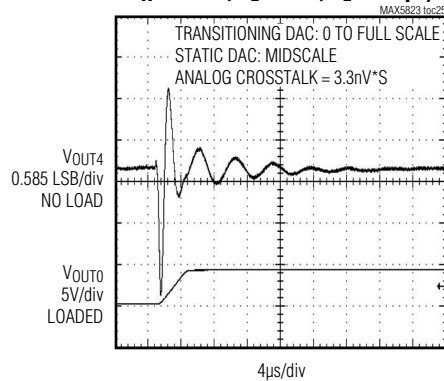

**DIGITAL FEEDTHROUGH**  
(V<sub>DD</sub> = V<sub>REF</sub> = 5V, R<sub>L</sub> = 10kΩ)

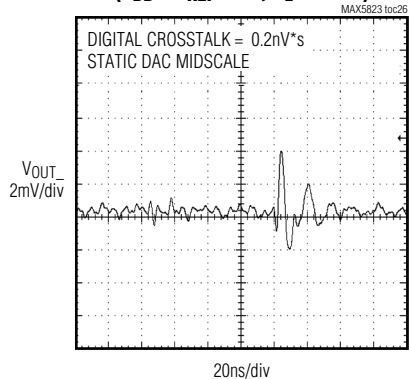

**OUTPUT LOAD REGULATION**

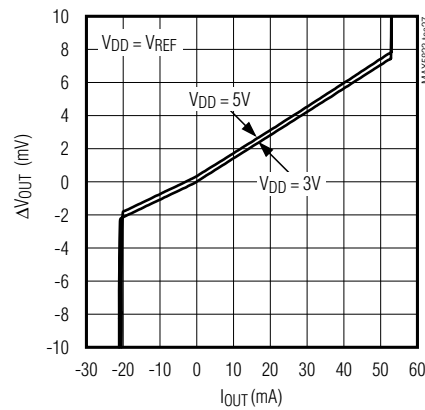

**OUTPUT CURRENT LIMITING**

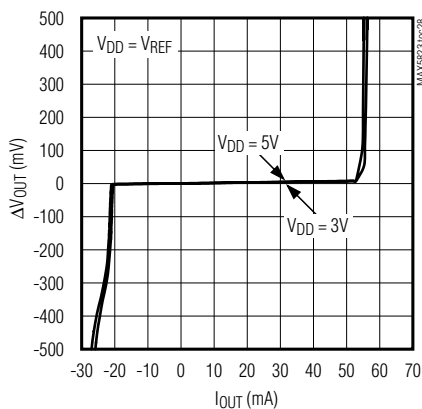

**HEADROOM AT RAILS**  
vs. OUTPUT CURRENT (V<sub>DD</sub> = V<sub>REF</sub>)

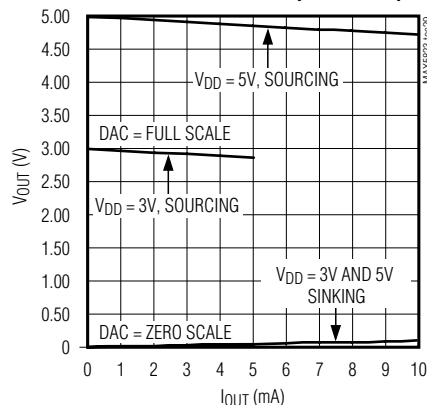

**NOISE-VOLTAGE DENSITY vs. FREQUENCY**  
(DAC AT MIDSACLE)

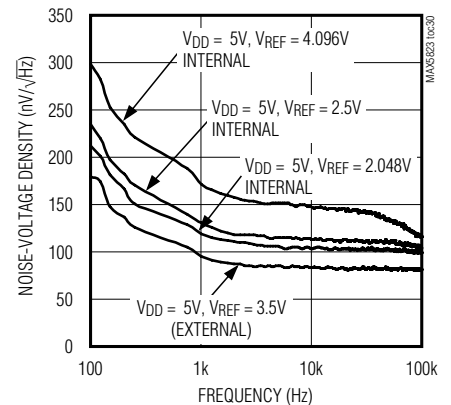

Typical Operating Characteristics (continued)

(MAX5825, 12-bit performance, T<sub>A</sub> = +25°C, unless otherwise noted.)

0.1Hz TO 10Hz OUTPUT NOISE, EXTERNAL  
REFERENCE (V<sub>DD</sub> = 5V, V<sub>REF</sub> = 4.5V)

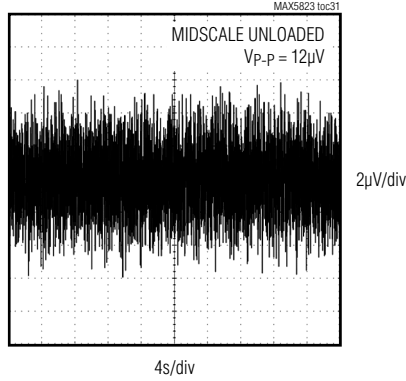

0.1Hz TO 10Hz OUTPUT NOISE, INTERNAL  
REFERENCE (V<sub>DD</sub> = 5V, V<sub>REF</sub> = 2.048V)

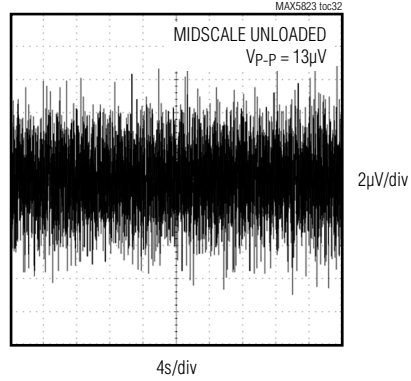

0.1Hz TO 10Hz OUTPUT NOISE, INTERNAL  
REFERENCE (V<sub>DD</sub> = 5V, V<sub>REF</sub> = 2.5V)

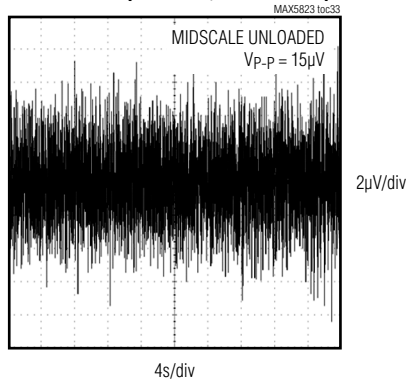

0.1Hz TO 10Hz OUTPUT NOISE, INTERNAL  
REFERENCE (V<sub>DD</sub> = 5V, V<sub>REF</sub> = 4.096V)

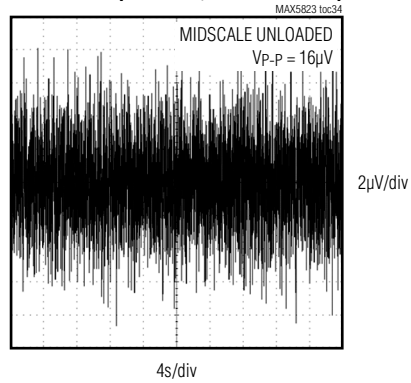

V<sub>REF</sub> DRIFT vs. TEMPERATURE

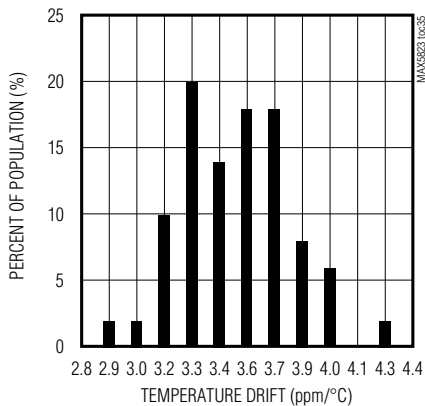

REFERENCE LOAD REGULATION

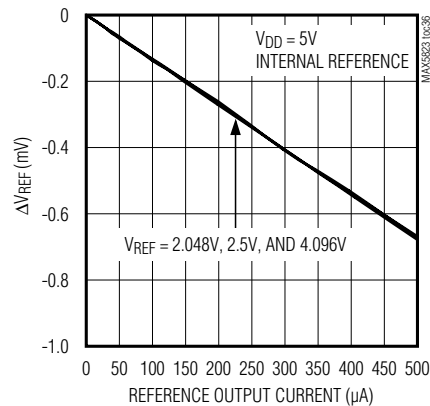

SUPPLY CURRENT vs. INPUT LOGIC VOLTAGE  
(V<sub>DD</sub> = 3V)

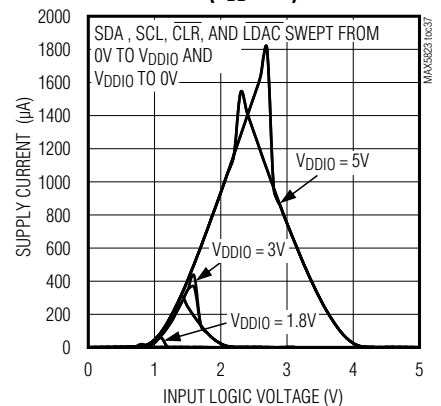

**Typical Operating Characteristics (continued)**

(MAX5825, 12-bit performance, T<sub>A</sub> = +25°C, unless otherwise noted.)

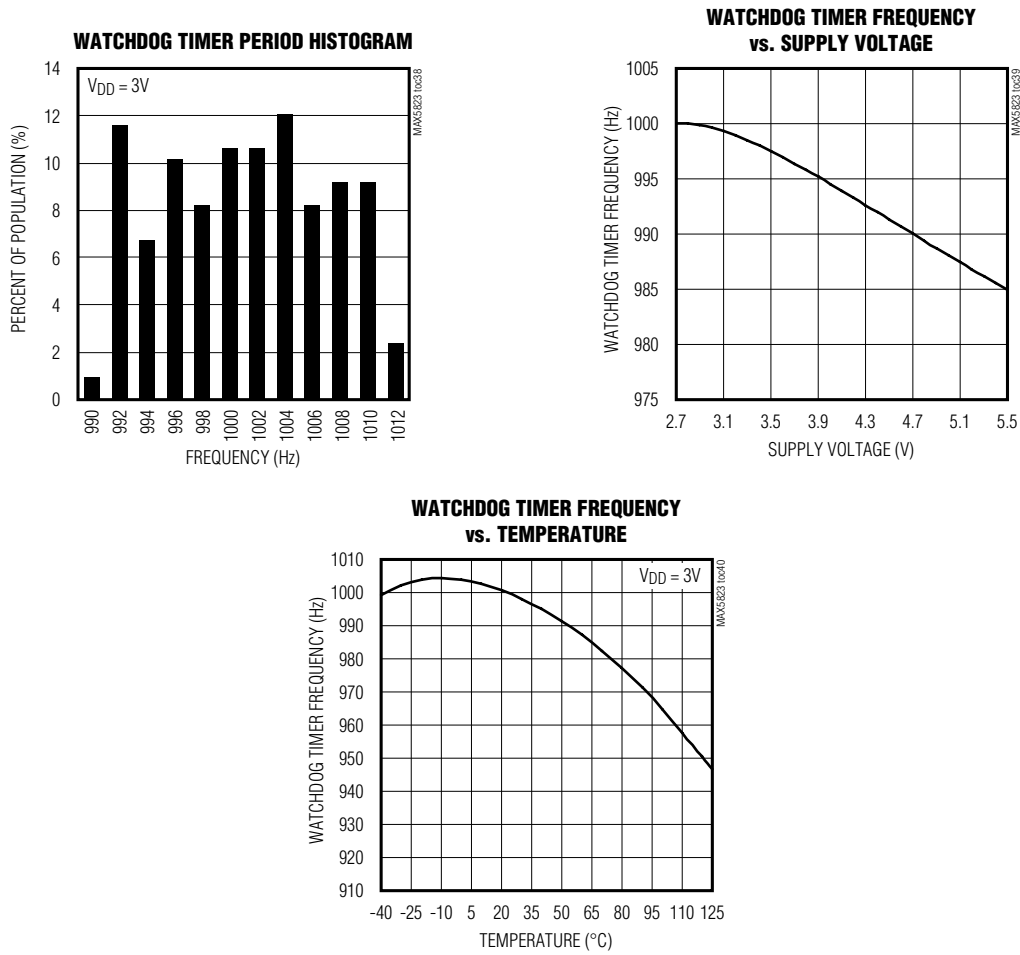

# MAX5823/MAX5824/ MAX5825

## Ultra-Small, Octal Channel, 8-/10-/12-Bit Buffered Output DACs with Internal Reference and I<sup>2</sup>C Interface

### Pin Configurations

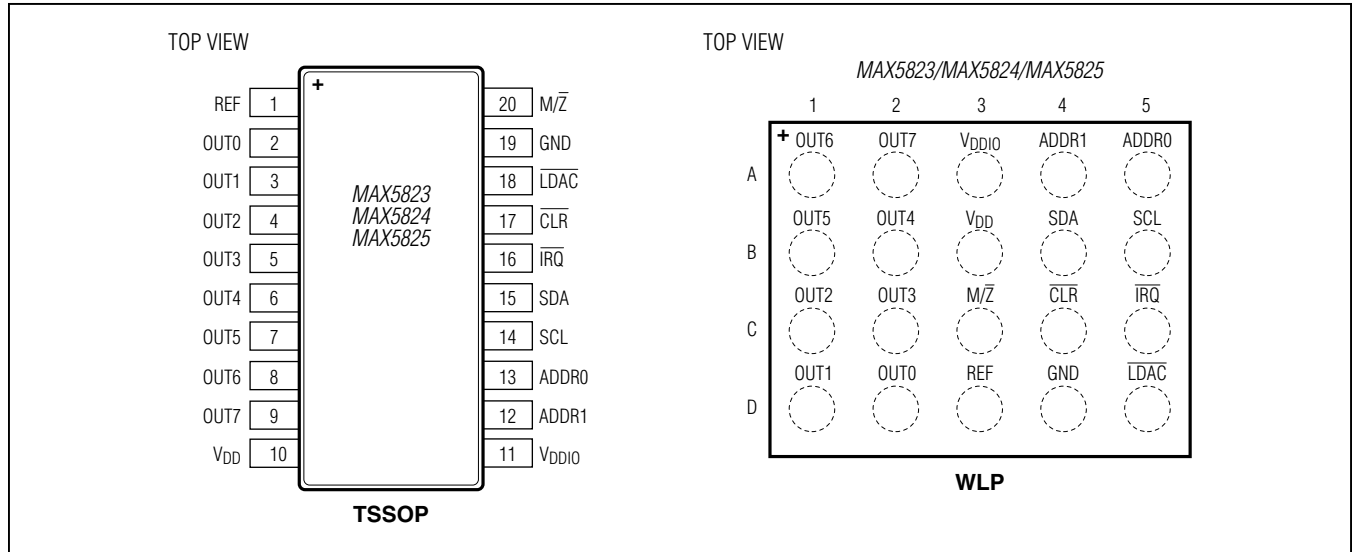

### Pin Description

PIN		NAME	FUNCTION
TSSOP	WLP		
1	D3	REF	Reference Voltage Input/Output
2	D2	OUT0	DAC Channel 0 Voltage Output
3	D1	OUT1	DAC Channel 1 Voltage Output
4	C1	OUT2	DAC Channel 2 Voltage Output
5	C2	OUT3	DAC Channel 3 Voltage Output
6	B2	OUT4	DAC Channel 4 Voltage Output
7	B1	OUT5	DAC Channel 5 Voltage Output
8	A1	OUT6	DAC Channel 6 Voltage Output
9	A2	OUT7	DAC Channel 7 Voltage Output
10	B3	V <sub>DD</sub>	Analog Supply Voltage
11	A3	V <sub>DDIO</sub>	Digital Supply Voltage
12	A4	ADDR1	I <sup>2</sup> C Address Selection Input Bit 1
13	A5	ADDR0	I <sup>2</sup> C Address Selection Input Bit 0
14	B5	SCL	I <sup>2</sup> C Serial Data Clock Input
15	B4	SDA	I <sup>2</sup> C Serial Data Bus Input/Output
16	C5	$\overline{\text{IRQ}}$	Active-Low Open Drain Interrupt Output. $\overline{\text{IRQ}}$ low indicates watchdog timeout.
17	C4	$\overline{\text{CLR}}$	Active-Low Asynchronous DAC Clear Input
18	D5	$\overline{\text{LDAC}}$	Active-Low Asynchronous DAC Load Input
19	D4	GND	Ground
20	C3	M/ $\bar{Z}$	DAC Output Reset Selection. Connect M/ $\bar{Z}$ to GND for zero-scale and connect M/ $\bar{Z}$ to V <sub>DD</sub> for midscale.

## Detailed Description

The MAX5823/MAX5824/MAX5825 are 8-channel, low-power, 8-/10-/12-bit buffered voltage-output DACs. The 2.7V to 5.5V wide supply voltage range and low-power consumption accommodates most low-power and low-voltage applications. The devices present a 100k $\Omega$  load to the external reference. The internal output buffers allow rail-to-rail operation. An internal voltage reference is available with software selectable options of 2.048V, 2.500V, or 4.096V. The devices feature a fast 400kHz I<sup>2</sup>C-compatible interface. The MAX5823/MAX5824/MAX5825 include a serial-in/parallel-out shift register, internal CODE and DAC registers, a power-on-reset (POR) circuit to initialize the DAC outputs to zero scale ( $M/\bar{Z} = 0$ ) or midscale ( $M/\bar{Z} = 1$ ), and control logic.

$\overline{\text{CLR}}$  is available to asynchronously clear the DAC outputs to a user-programmable default value, independent of the serial interface.  $\overline{\text{LDAC}}$  is available to simultaneously update selected DACs on one or more devices. The MAX5823/MAX5824/MAX5825 also feature user-configurable interface watchdog, with status indicated by the IRQ output.

## DAC Outputs (OUT<sub>n</sub>)

The MAX5823/MAX5824/MAX5825 include internal buffers on all DAC outputs, which provide improved load regulation for the DAC outputs. The output buffers slew at 1V/ $\mu\text{s}$  (typ) and drive as low as 2k $\Omega$  in parallel with 500pF. The analog supply voltage ( $V_{\text{DD}}$ ) determines the maximum output voltage range of the devices since it powers the output buffers. Under no-load conditions, the output buffers drive from GND to  $V_{\text{DD}}$ , subject to offset and gain errors. With a 2k $\Omega$  load to GND, the output buffers drive from GND to within 200mV of  $V_{\text{DD}}$ . With a 2k $\Omega$  load to  $V_{\text{DD}}$ , the output buffers drive from  $V_{\text{DD}}$  to within 200mV of GND.

The DAC ideal output voltage is defined by:

$$V_{\text{OUT}} = V_{\text{REF}} \times \frac{D}{2^N}$$

where D = code loaded into the DAC register,  $V_{\text{REF}}$  = reference voltage, N = resolution.

## Internal Register Structure

The user interface is separated from the DAC logic to minimize digital feedthrough. Within the serial interface is an input shift register, the contents of which can be routed to control registers, individual, or multiple DACs as determined by the user command.

Within each DAC channel there is a CODE register followed by a DAC latch register (see the [Detailed Functional Diagram](#)). The contents of the CODE register hold pending DAC output settings which can later be loaded into the DAC registers. The CODE register can be updated using both CODE and CODE\_LOAD user commands. The contents of the DAC register hold the current DAC output settings. The DAC register can be updated directly from the serial interface using the CODE\_LOAD commands or can upload the current contents of the CODE register using LOAD commands or the  $\overline{\text{LDAC}}$  logic input.

The contents of both CODE and DAC registers are maintained during power-down states, so that when the DACs are powered on, they return to their previously stored output settings. Any CODE or LOAD commands issued during power-down states continue to update the register contents.

Once the device is powered up, each DAC channel can be independently programmed with a desired RETURN value using the RETURN command. This becomes the value the CODE and DAC registers will use in the event of any watchdog, clear or gate activity, as selected by the DEFAULT command.

Hardware  $\overline{\text{CLR}}$  operations and SW\_CLEAR commands return the contents of all CODE and DAC registers to their user-selected defaults. SW\_RESET commands will reset CODE and DAC register contents to their  $M/\bar{Z}$  selected initial codes. A SW\_GATE state can be used to momentarily hold selected DAC outputs in their DEFAULT positions. The contents of CODE and DAC registers can be manipulated by watchdog timer activity, enabling a variety of safety features.

## Internal Reference

The MAX5823/MAX5824/MAX5825 include an internal precision voltage reference that is software selectable to be 2.048V, 2.500V, or 4.096V. When an internal reference is selected, that voltage is available on the REF output for other external circuitry (see the [Typical Operating Circuits](#)) and can drive loads down to 25k $\Omega$ .

# MAX5823/MAX5824/ MAX5825

# Ultra-Small, Octal Channel, 8-/10-/12-Bit Buffered Output DACs with Internal Reference and I<sup>2</sup>C Interface

## External Reference

The external reference input has a typical input impedance of 100kΩ and accepts an input voltage from +1.24V to V<sub>DD</sub>. Apply an external voltage between REF and GND to use an external reference. The MAX5823/MAX5824/MAX5825 power up and reset to external reference mode. Visit [www.maximintegrated.com/products/references](http://www.maximintegrated.com/products/references) for a list of available external voltage-reference devices.

## M/ $\bar{Z}$ Input

The MAX5823/MAX5824/MAX5825 feature a pin selectable DAC reset state using the M/ $\bar{Z}$  input. Upon a power-on reset, all CODE and DAC data registers are reset to zero scale (M/ $\bar{Z}$  = GND) or midscale (M/ $\bar{Z}$  = V<sub>DD</sub>). M/ $\bar{Z}$  is referenced to V<sub>DD</sub> (not V<sub>DDIO</sub>). In addition, M/ $\bar{Z}$  must be valid at the time the device is powered up—connect M/ $\bar{Z}$  directly to V<sub>DD</sub> or GND.

## Load DAC ( $\bar{L}DAC$ ) Input

The MAX5823/MAX5824/MAX5825 feature an active-low asynchronous  $\bar{L}DAC$  logic input that allows DAC outputs to update simultaneously. Connect  $\bar{L}DAC$  to V<sub>DDIO</sub> or keep  $\bar{L}DAC$  high during normal operation when the device is controlled only through the serial interface. Drive  $\bar{L}DAC$  low to update the DAC outputs with data from the CODE registers. Holding  $\bar{L}DAC$  low causes the DAC registers to become transparent and CODE data is passed through to the DAC registers immediately updating the DAC outputs. A software CONFIG command can be used to configure the  $\bar{L}DAC$  operation of each DAC independently.

## Clear ( $\bar{CLR}$ ) Input

The MAX5823/MAX5824/MAX5825 feature an asynchronous active-low CLR logic input that simultaneously sets all selected DAC outputs to their programmable DEFAULT states. Driving  $\bar{CLR}$  low clears the contents of both the CODE and DAC registers and also ignores any on-going I<sup>2</sup>C command which modifies registers associated with a DAC configured to accept clear operations. To allow a new I<sup>2</sup>C command, drive  $\bar{CLR}$  high, satisfying the t<sub>CLRSTA</sub> timing requirement. A software CONFIG command can be used to configure the clear operation of each DAC independently.

## Watchdog Feature

The MAX5823/MAX5824/MAX5825 feature an interface watchdog timer with programmable timeout duration. This

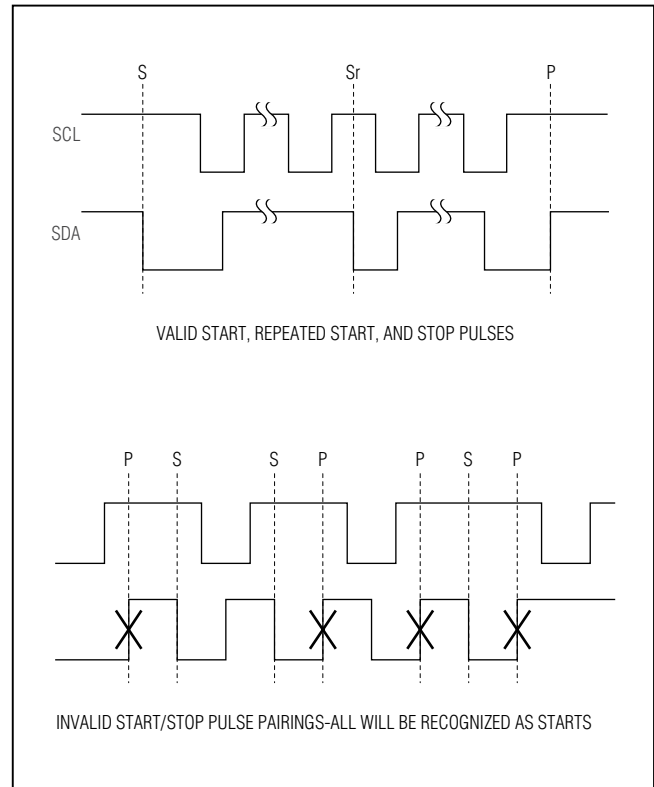

Figure 2. I<sup>2</sup>C START, Repeated START, and STOP Conditions

monitors the I/O interface for activity and integrity. If the watchdog is enabled, the host processor must write a valid command to the device within the timeout period to prevent a timeout. If the watchdog is allowed to timeout, selected DAC outputs are returned to the programmable DEFAULT state, protecting the system against control faults.

By default, all watchdog features are disabled; users wishing to activate any watchdog feature must configure the device accordingly. Individual DAC channels can be configured using the CONFIG command to accept the watchdog alarm and to gate, clear, or hold their outputs in response to an alarm. A watchdog refresh event and watchdog behavior upon timeout is defined by a programmable safety level using the WDOG\_CONFIG command.

## IRQ Output

The MAX5823/MAX5824/MAX5825 feature an active-low open-drain interrupt output indicating to the host when a watchdog timeout has occurred.

# MAX5823/MAX5824/ MAX5825

# Ultra-Small, Octal Channel, 8-/10-/12-Bit Buffered Output DACs with Internal Reference and I<sup>2</sup>C Interface

## Interface Power Supply (V<sub>DDIO</sub>)

The MAX5823/MAX5824/MAX5825 feature a separate supply input (V<sub>DDIO</sub>) for the digital interface (1.8V to 5.5V). Connect V<sub>DDIO</sub> to the I/O supply of the host processor.

## I<sup>2</sup>C Serial Interface

The MAX5823/MAX5824/MAX5825 feature an I<sup>2</sup>C-/SMBus™-compatible, 2-wire serial interface consisting of a serial data line (SDA) and a serial clock line (SCL). SDA and SCL enable communication between the MAX5823/MAX5824/MAX5825 and the master at clock rates up to 400kHz. [Figure 1](#) shows the 2-wire interface timing diagram. The master generates SCL and initiates data transfer on the bus. The master device writes data to the MAX5823/MAX5824/MAX5825 by transmitting the proper slave address followed by the command byte and then the data word. Each transmit sequence is framed by a START (S) or Repeated START (Sr) condition and a STOP (P) condition. Each word transmitted to the MAX5823/MAX5824/MAX5825 is 8 bits long and is followed by an acknowledge clock pulse. A master reading data from the MAX5823/MAX5824/MAX5825 must transmit the proper slave address followed by a series of nine SCL pulses for each byte of data requested. The MAX5823/MAX5824/MAX5825 transmit data on SDA in sync with the master-generated SCL pulses. The master acknowledges receipt of each byte of data. Each read sequence is framed by a START or Repeated START condition, a not acknowledge, and a STOP condition. SDA operates as both an input and an open-drain output. A pullup resistor, typically 4.7kΩ is required on SDA. SCL operates only as an input. A pullup resistor, typically 4.7kΩ, is required on SCL if there are multiple masters on the bus, or if the single master has an open-drain SCL output.

Series resistors in line with SDA and SCL are optional. Series resistors protect the digital inputs of the MAX5823/MAX5824/MAX5825 from high voltage spikes on the bus lines and minimize crosstalk and undershoot of the bus signals. The MAX5823/MAX5824/MAX5825 can accommodate bus voltages higher than V<sub>DDIO</sub> up to a limit of 5.5V; bus voltages lower than V<sub>DDIO</sub> are not recommended and may result in significantly increased interface currents. The MAX5823/MAX5824/MAX5825 digital inputs are double buffered. Depending on the command

**Table 1. I<sup>2</sup>C Slave Address LSBs**

ADDR1	ADDR0	A3	A2	A1	A0
V <sub>DDIO</sub>	V <sub>DDIO</sub>	1	1	1	1
V <sub>DDIO</sub>	N.C.	1	1	1	0
V <sub>DDIO</sub>	GND	1	1	0	0
N.C.	V <sub>DD</sub>	1	0	1	1
N.C.	N.C.	1	0	1	0
N.C.	GND	1	0	0	0
GND	V <sub>DDIO</sub>	0	0	1	1
GND	N.C.	0	0	1	0
GND	GND	0	0	0	0

issued through the serial interface, the CODE register(s) can be loaded without affecting the DAC register(s) using the write command. To update the DAC registers, either drive the LDAC input low to simultaneously update all DAC outputs, or use the software LOAD command.

## I<sup>2</sup>C START and STOP Conditions

SDA and SCL idle high when the bus is not in use. A master initiates communication by issuing a START condition. A START condition is a high-to-low transition on SDA with SCL high. A STOP condition is a low-to-high transition on SDA while SCL is high ([Figure 2](#)). A START condition from the master signals the beginning of a transmission to the MAX5823/MAX5824/MAX5825. The master terminates transmission and frees the bus, by issuing a STOP condition. The bus remains active if a Repeated START condition is generated instead of a STOP condition.

## I<sup>2</sup>C Early STOP and Repeated START Conditions

The MAX5823/MAX5824/MAX5825 recognize a STOP condition at any point during data transmission except if the STOP condition occurs in the same high pulse as a START condition. Transmissions ending in an early STOP condition will not impact the internal device settings. If the STOP occurs during a readback byte, the transmission is terminated and a later read mode request will begin transfer of the requested register data from the beginning (this applies to combined format I<sup>2</sup>C read mode transfers only), interface verification mode transfers will be corrupted. See [Figure 2](#).

*SMBus is a trademark of Intel Corp.*

# MAX5823/MAX5824/ MAX5825

# Ultra-Small, Octal Channel, 8-/10-/12-Bit Buffered Output DACs with Internal Reference and I<sup>2</sup>C Interface

## I<sup>2</sup>C Slave Address

The slave address is defined as the seven most significant bits (MSBs) followed by the R/W bit. See [Figure 4](#). The three most significant bits are 001 with the 4 LSBs determined by ADDR1 and ADDR0 as shown in [Table 1](#). Setting the R/W bit to 1 configures the MAX5823/MAX5824/MAX5825 for read mode. Setting the R/W bit to 0 configures the MAX5823/MAX5824/MAX5825 for write mode. The slave address is the first byte of information sent to the MAX5823/MAX5824/MAX5825 after the START condition.

The MAX5823/MAX5824/MAX5825 has the ability to detect an unconnected (N.C.) state on the ADDR\_ inputs for additional address flexibility; if disconnecting the ADDR\_ inputs, be certain to minimize all loading on the ADDR\_ inputs (i.e. provide a landing for ADDR\_, but do not allow any board traces).

## I<sup>2</sup>C Broadcast Address

A broadcast address is provided for the purpose of updating or configuring all MAX5823/MAX5824/MAX5825 devices on a given I<sup>2</sup>C bus. All MAX5823/MAX5824/

MAX5825 devices acknowledge and respond to the broadcast device address 00101000, regardless of the state of the address pins. The broadcast mode is intended for use in write mode only (as indicated by R/W = 0 in the address given).

## I<sup>2</sup>C Acknowledge

In write mode, the acknowledge bit (ACK) is a clocked 9th bit that the MAX5823/MAX5824/MAX5825 use to handshake receipt of each byte of data as shown in [Figure 3](#). The MAX5823/MAX5824/MAX5825 pull down SDA during the entire master-generated 9th clock pulse if the previous byte is successfully received. Monitoring ACK allows for detection of unsuccessful data transfers. An unsuccessful data transfer occurs if a receiving device is busy or if a system fault has occurred. In the event of an unsuccessful data transfer, the bus master will retry communication.

In read mode, the master pulls down SDA during the 9th clock cycle to acknowledge receipt of data from the MAX5823/MAX5824/MAX5825. An acknowledge is sent by the master after each read byte to allow data transfer to continue. A not-acknowledge is sent when the master reads the final byte of data from the MAX5823/MAX5824/MAX5825, followed by a STOP condition.

## I<sup>2</sup>C Command Byte and Data Bytes

A command byte follows the slave address. A command byte is typically followed by two data bytes unless it is the last byte in the transmission. If data bytes follow the command byte, the command byte indicates the address of the register that is to receive the following two data bytes. The data bytes are stored in a temporary register and then transferred to the appropriate register during the ACK periods between bytes. This avoids any glitching or digital feedthrough to the DACs while the interface is active.

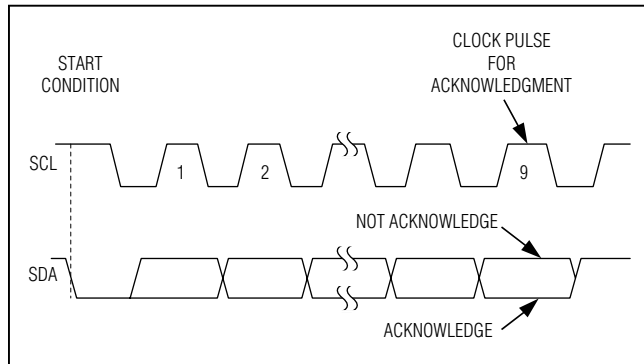

Figure 3. I<sup>2</sup>C Acknowledge

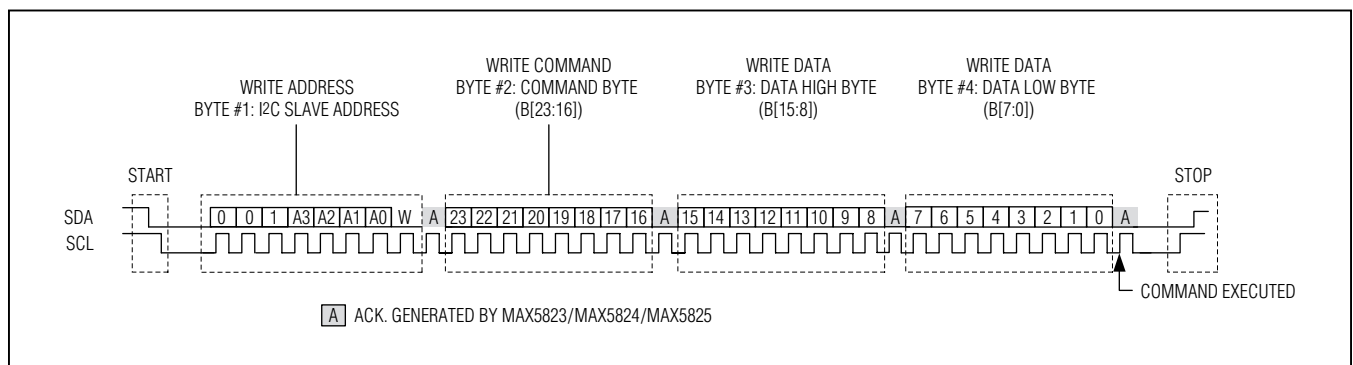

Figure 4. I<sup>2</sup>C Single Register Write Sequence

**I<sup>2</sup>C Write Operations**

A master device communicates with the MAX5823/MAX5824/MAX5825 by transmitting the proper slave address followed by command and data words. Each transmit sequence is framed by a START or Repeated START condition and a STOP condition as described above. Each word is 8 bits long and is always followed by an acknowledge clock (ACK) pulse as shown in the Figure 4 and Figure 5. The first byte contains the address of the MAX5823/MAX5824/MAX5825 with R/W = 0 to indicate a write. The second byte contains the register (or command) to be written and the third and fourth bytes contain the data to be written. By repeating the register address plus data pairs (Byte #2 through Byte #4 in Figure 4 and Figure 5), the user can perform multiple register writes using a single I<sup>2</sup>C command sequence. There is no limit as to how many registers the user can write with a single command. The MAX5823/MAX5824/MAX5825 support this capability for all user-accessible write mode commands.

**Combined Format I<sup>2</sup>C Readback Operations**

Each readback sequence is framed by a START or Repeated START condition and a STOP condition. Each word is 8 bits long and is followed by an acknowledge clock pulse as shown in Figure 6. The first byte contains the address of the MAX5823/MAX5824/MAX5825 with R/W = 0 to indicate a write. The second byte contains the register that is to be read back. There is a Repeated START condition, followed by the device address with R/W = 1 to indicate a read and an acknowledge clock. The master has control of the SCL line but the MAX5823/MAX5824/MAX5825 take over the SDA line. The final two bytes in the frame contain the register data readback followed by a STOP condition. If additional bytes beyond those required to readback the requested data are provided, the MAX5823/MAX5824/MAX5825 will continue to readback ones.

Readback of the WDOG command (B[23:20] = 0001) is directly supported, confirming the current watchdog timeout selection, mask status, and safety level.

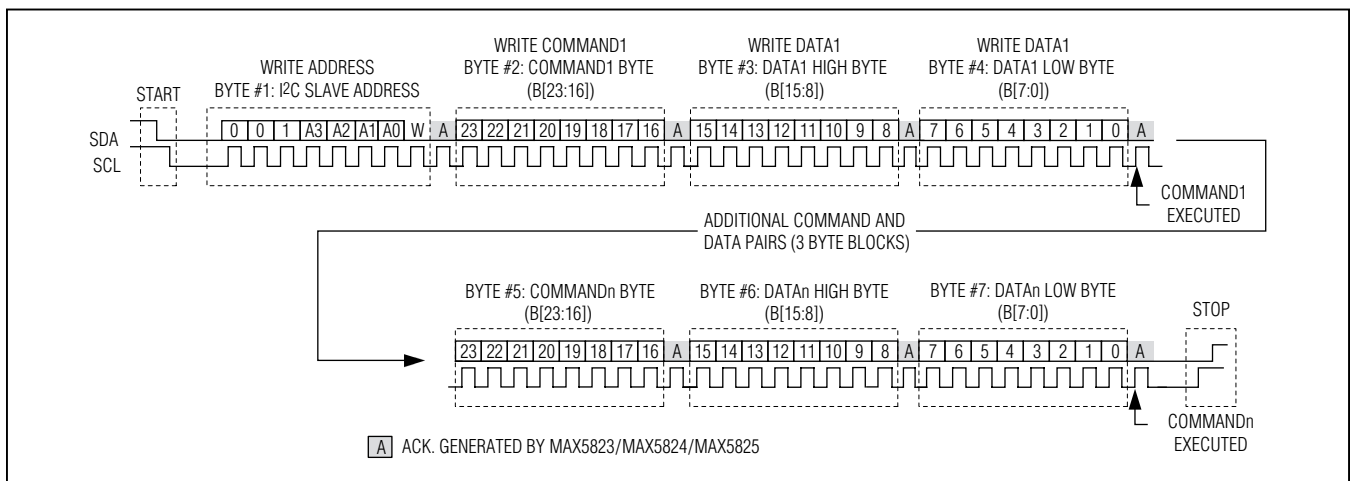

Figure 5. Multiple Register Write Sequence (Standard I<sup>2</sup>C Protocol)

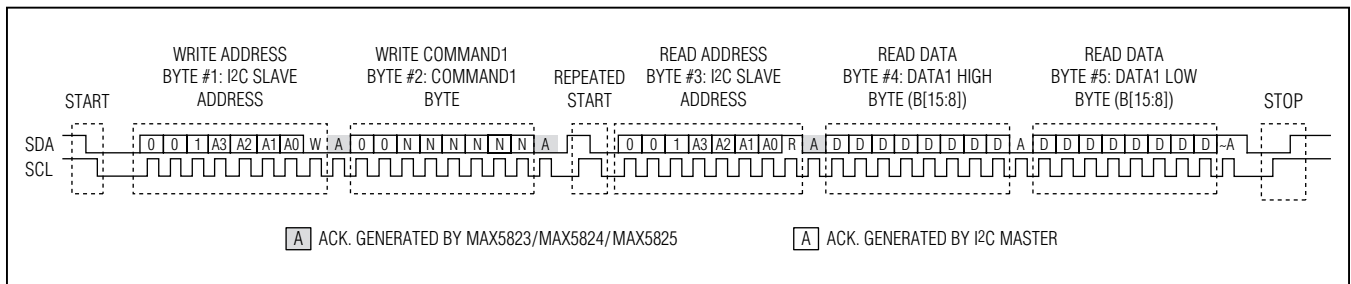

Figure 6. Standard I<sup>2</sup>C Register Read Sequence

Readback of individual RETURN registers is supported for RETURN commands (B[23:20] = 0111). For this command, which supports a DAC address, the requested channel RETURN register content will be returned, along with the selected DAC address. If all DACs are selected, readback will begin with RETURN0 content and will progress through the remaining DAC channels. The RETURN\_ALL (B[23:16] = 11000011) command behaves identically to the RETURN command with all DACs selected.

Readback of individual CODE registers is supported for the CODE commands (B[23:20] = 1000). For this command, which supports a DAC address, the requested channel CODE register content will be returned, along with the selected DAC address. If all DACs are selected, readback will begin with CODE0 content and will progress through the remaining DAC channels. The CODE\_ALL (B[23:16] = 11000000) command behaves identically to the CODE command with all DACs selected.

Readback of individual DAC registers is supported for all LOAD commands (B[23:20] = 1001, 1010, 1011). For these commands, which support a DAC address, the requested DAC register content will be returned, along with the selected DAC address. If all DACs are selected, readback will begin with DAC0 content and will progress through the remaining DAC channels. The LOAD\_ALL and CODE\_ALL\_LOAD\_ALL commands (B[23:16] =

11000001 and 11000010, respectively) behave identically to the LOAD command with all DACs selected.

Modified readback of the POWER register is supported for the POWER command (B[23:20] = 0100). The power status of each DAC is reported in locations B[7:0], with a 1 indicating the DAC is powered down and a zero indicating the DAC is operational (see [Table 2](#)).

Readback of all other registers is not directly supported. All requests to read unsupported registers reads back the device's current watchdog timer status (WD:0 = normal, 1 = timed out), reference setting (REF[2:0]), and CLR condition, along with the device revision (B[10:8] = 001) and part ID (B[7:0]) in the format as shown in [Table 2](#).

### Interface Verification I<sup>2</sup>C Readback Operations

While the MAX5823/MAX5824/MAX5825 support standard I<sup>2</sup>C readback of selected registers, it is also capable of functioning in an interface verification mode. This mode is accessed any time a readback operation follows an executed write mode command. In this mode, the last executed three-byte command is read back in its entirety. This behavior allows verification of the interface.

Sample command sequences are shown in [Figure 7](#). The first command transfer is given in write mode with R/W = 0 and must be run to completion to qualify for interface verification readback. There is now a STOP/

**Table 2. Standard I<sup>2</sup>C User Readback Data**

COMMAND BYTE (REQUEST)								READBACK DATA HIGH BYTE								READBACK DATA LOW BYTE							
B23	B22	B21	B20	B19	B18	B17	B16	B15	B14	B13	B12	B11	B10	B9	B8	B7	B6	B5	B4	B3	B2	B1	B0
0	0	0	1	X	X	X	X	WDOG Timeout Selection[11:4]								Timeout Selection[3:0]			WDM	WL[1:0]		0	
0	1	0	0	X	X	X	X	0	0	0	0	0	0	0	0	PW7	PW6	PW5	PW4	PW3	PW2	PW1	PW0
0	1	1	1	DAC SELECTION				RETURNn[11:4]								RETURNn[3:0]			ADDRESSn[3:0]				
1	0	0	0	DAC SELECTION				CODEn[11:4]								CODEn[3:0]			ADDRESSn[3:0]				
1	0	0	1	DAC SELECTION				DACn[11:4]								DACn[3:0]			ADDRESSn[3:0]				
1	0	1	0	DAC SELECTION				DACn[11:4]								DACn[3:0]			ADDRESSn[3:0]				
1	0	1	1	DAC SELECTION				DACn[11:4]								DACn[3:0]			ADDRESSn[3:0]				
1	1	0	0	0	0	0	0	CODE0[11:4]								CODE0[3:0]			ADDRESS0[3:0]				
1	1	0	0	0	0	0	1	DAC0[11:4]								DAC0[3:0]			ADDRESS0[3:0]				
1	1	0	0	0	0	1	0	DAC0[11:4]								DAC0[3:0]			ADDRESS0[3:0]				
1	1	0	0	0	0	1	1	RETURN0[11:4]								RETURN0[03:0]			ADDRESS0[3:0]				
All Other Commands (MAX5825)								WD	REF[2:0]			CLR		REV_ID [2:0] (001)		1	0	0	0	0	0	0	0
All Other Commands (MAX5824)																1	0	1	0	0	0	0	0
All Other Commands (MAX5823)																1	0	0	1	0	0	0	0

Table 3. Format DAC Data Bit Positions

PART	B15	B14	B13	B12	B11	B10	B9	B8	B7	B6	B5	B4	B3	B2	B1	B0
MAX5823	D7	D6	D5	D4	D3	D2	D1	D0	X	X	X	X	X	X	X	X
MAX5824	D9	D8	D7	D6	D5	D4	D3	D2	D1	D0	X	X	X	X	X	X
MAX5825	D11	D10	D9	D8	D7	D6	D5	D4	D3	D2	D1	D0	X	X	X	X

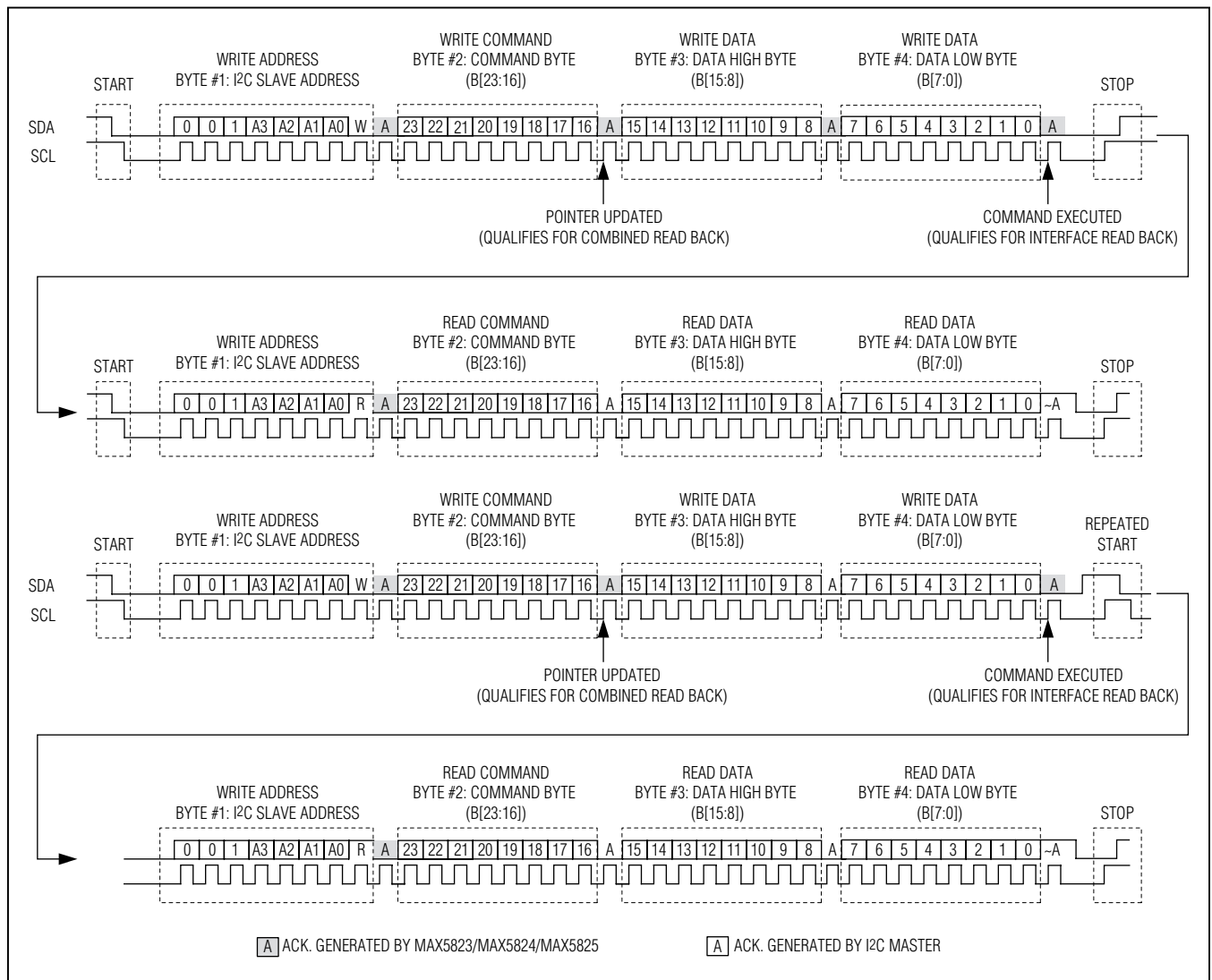

Figure 7. Interface Verification I<sup>2</sup>C Register Read Sequences

# MAX5823/MAX5824/ MAX5825

## Ultra-Small, Octal Channel, 8-/10-/12-Bit Buffered Output DACs with Internal Reference and I<sup>2</sup>C Interface

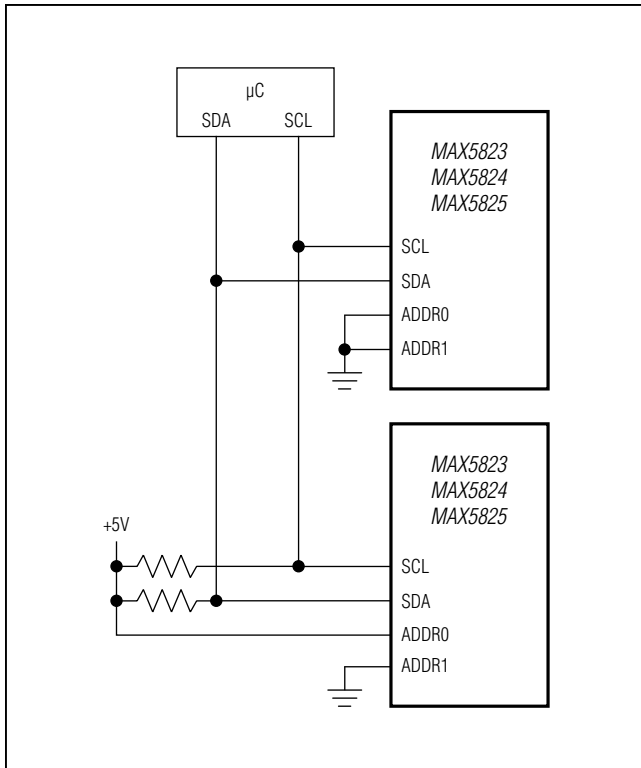

Figure 8. Typical I<sup>2</sup>C Application Circuit

START pair or Repeated START condition required, followed by the readback transfer with  $R/\bar{W} = 1$  to indicate a read and an acknowledge clock from the MAX5823/MAX5824/MAX5825. The master still has control of the SCL line but the MAX5823/MAX5824/MAX5825 take over the SDA line. The final three bytes in the frame contain the command and register data written in the first transfer

presented for readback, followed by a STOP condition. If additional bytes beyond those required to readback the requested data are provided, the MAX5823/MAX5824/MAX5825 will continue to readback ones.

It is not necessary for the write and read mode transfers to occur immediately in sequence. I<sup>2</sup>C transfers involving other devices do not impact the MAX5823/MAX5824/MAX5825 readback mode. Toggling between readback modes is based on the length of the preceding write mode transfer. Combined format I<sup>2</sup>C readback operation is resumed if a write command greater than two bytes but less than four bytes is supplied. For commands written using multiple register write sequences, only the last command executed is read back. For each command written, the readback sequence can only be completed one time; partial and/or multiple attempts to readback executed in succession will not yield usable data.

### I<sup>2</sup>C Compatibility

The MAX5823/MAX5824/MAX5825 are fully compatible with existing I<sup>2</sup>C systems. SCL and SDA are high-impedance inputs; SDA has an open drain which pulls the data line low to transmit data or ACK pulses. [Figure 8](#) shows a typical I<sup>2</sup>C application.

### I<sup>2</sup>C User-Command Register Map

This section lists the user-accessible commands and registers for the MAX5823/MAX5824/MAX5825.

[Table 4](#) provides detailed information about the Command Registers.

Table 4. I<sup>2</sup>C Commands Summary

COMMAND	B23	B22	B21	B20	B19	B18	B17	B16	B15	B14	B13	B12	B11	B10	B9	B8	B7	B6	B5	B4	B3	B2	B1	B0	DESCRIPTION	
<b>CONFIGURATION AND SOFTWARE COMMANDS</b>																										
WDOG	0	0	0	1	X	X	X																	X	Updates watchdog settings and safety levels	
REF	0	0	1	0	0	0	0																		X	Sets the reference operating mode. REF Power (B18): 0 = Internal reference is only powered if at least one DAC is powered. 1 = Internal reference is always powered.
SW_GATE_CLR	0	0	1	1	0	0	0																		0	Removes any existing GATE condition
SM_GATE_SET	0	0	1	1	0	0	1																		0	Initiates a GATE condition
WD_REFRESH	0	0	1	1	0	0	1																		0	Refreshes the watchdog timer
WD_RESET	0	0	1	1	0	0	1																		0	Resets the watchdog timeout alarm status and refreshes the watchdog timer
SW_CLEAR	0	0	1	1	0	0	1																		0	Executes a software clear (all CODE and DAC registers cleared to their default values)
SW_RESET	0	0	1	1	0	0	1																		0	Executes a software reset (all CODE, DAC, and Control registers returned to their power-on reset values)
POWER	0	1	0	0	0	0	0																		X	Sets the Power mode of the selected DACs (DACs selected with a 1 in the corresponding DACn bit are updated. DACs with a 0 in the corresponding DACn bit are not impacted)
CONFIG	0	1	0	1	0	0	0																		X	Configures selected DAC watchdog, GATE, LOAD, and CLEAR operations. DACs selected with a 1 in the corresponding DACn bit are updated. DACs with a 0 in the corresponding DACn bit are not impacted)

Table 4. I<sup>2</sup>C Commands Summary (continued)

COMMAND	B23	B22	B21	B20	B19	B18	B17	B16	B15	B14	B13	B12	B11	B10	B9	B8	B7	B6	B5	B4	B3	B2	B1	B0	DESCRIPTION
DEFAULT	0	1	1	0	0	0	0	0		DAC 7	DAC 6	DAC 5	DAC 4	DAC 3	DAC 2	DAC 1	DAC 0	Default Values: 000: MIZ 001: ZERO 010: MID 011: FULL 100: RETURN 101+: No Effect							Sets the default code settings for selected DACs. Note: DACs in RETURN mode programmable RETURN codes. (DACs selected with a 1 in the corresponding DACn bit are updated. DACs with a 0 in the corresponding DACn bit are not impacted)
<b>DAC COMMANDS</b>																									
RETURNn	0	1	1	1			DAC SELECTION					RETURN REGISTER DATA[11:4]							RETURN REGISTER DATA[3:0]		X	X	X	X	Writes data to the selected RETURN register(s)
CODEn	1	0	0	0			DAC SELECTION					CODE REGISTER DATA[11:4]							CODE REGISTER DATA[3:0]		X	X	X	X	Writes data to the selected CODE register(s)
LOADn	1	0	0	1			DAC SELECTION		X	X	X	X	X	X	X	X	X	X	X	X	X	X	X	X	Transfers data from the selected CODE registers to the selected DAC register(s)
CODEn_LOAD_ALL	1	0	1	0			DAC SELECTION					CODE REGISTER DATA[11:4]							CODE REGISTER DATA[3:0]		X	X	X	X	Simultaneously writes data to the selected CODE register(s) while updating all DAC registers
CODEn_LOADn	1	0	1	1			DAC SELECTION					CODE REGISTER DATA[11:4]							CODE REGISTER DATA[3:0]		X	X	X	X	Simultaneously writes data to the selected CODE register(s) while updating selected DAC register(s)
CODE_ALL	1	1	0	0	0	0	0	0	0	0	0	CODE REGISTER DATA[11:4]							CODE REGISTER DATA[3:0]		X	X	X	X	Writes data to all CODE registers
LOAD_ALL	1	1	0	0	0	0	0	1	X	X	X	X	X	X	X	X	X	X	X	X	X	X	X	X	Updates all DAC latches with current CODE register data
CODE_ALL_LOAD_ALL	1	1	0	0	0	0	1	0				CODE REGISTER DATA[11:4]							CODE REGISTER DATA[3:0]		X	X	X	X	Simultaneously writes data to the all CODE registers while updating all DAC registers
RETURN_ALL	1	1	0	0	0	0	1	1				RETURN REGISTER DATA[11:4]							RETURN REGISTER DATA[3:0]		X	X	X	X	Writes data to all RETURN registers
<b>NO OPERATION COMMANDS</b>																									
No Operation	1	1	0	0	0	1	X	X	X	X	X	X	X	X	X	X	X	X	X	X	X	X	X	X	These commands will have no effect on the device, but will refresh the watchdog timer if safety level is set to Low
<b>Reserved Commands:</b> Any commands not specifically listed above are reserved for Maxim internal use only.																									

### RETURNn Command

The RETURNn command (B[23:20] = 0111) sets the programmable default RETURN value. This value is used for all future watchdog, clear, and gate operations when RET is selected for the DAC using the DEFAULT command. Issuing this command with DAC\_ADDRESS set to all DACs will program the value for all RETURN registers and is equivalent to RETURN\_ALL. **Note:** This command is inaccessible when a watchdog timeout has occurred if the watchdog timer is configured for safety level = high or max.

### CODEn Command

The CODEn command (B[23:20] = 1000) updates the CODE register contents for the selected DAC(s). Changes to the CODE register content based on this command will not affect DAC outputs directly unless the  $\overline{\text{LDAC}}$  input is in a low state or the DAC latch has been configured as transparent using the CONFIG command. Issuing this command with DAC\_ADDRESS set to all DACs will program the value for all CODE registers and is equivalent to CODE\_ALL.

### LOADn Command

The LOADn command (B[23:20] = 1001) updates the DAC register content for the selected DAC(s) by uploading the current contents of the selected CODE register(s) into the selected DAC register(s). Channels for which CODE content has not been modified since the last LOAD or  $\overline{\text{LDAC}}$  operation will not be updated to reduce digital crosstalk. Issuing this command with DAC\_ADDRESS set to all DACs will update the contents of all DAC registers and is equivalent to LOAD\_ALL.

### CODEn\_LOADn Command

The CODEn\_LOADn command (B[23:20] = 1011) updates the CODE register contents for the selected DAC(s) as well as the DAC register content of the selected DAC(s). Channels for which CODE content has not been modified since the last LOAD or  $\overline{\text{LDAC}}$  operation will not be updated to reduce digital crosstalk. Issuing this command with DAC\_ADDRESS set to all DACs is equivalent to the CODE\_ALL\_LOAD\_ALL (B[23:16] = 1100\_0010) command.

### CODEn\_LOAD\_ALL Command

The CODEn\_LOAD\_ALL command (B[23:20] = 1010) updates the CODE register contents for the selected DAC(s) as well as the DAC register content of all DACs. Channels for which CODE content has not been modified since the last LOAD or  $\overline{\text{LDAC}}$  operation will not be updated

**Table 5. DAC Selection**

B19	B18	B17	B16	DAC SELECTED
0	0	0	0	DAC0
0	0	0	1	DAC1
0	0	1	0	DAC2
0	0	1	1	DAC3
0	1	0	0	DAC4
0	1	0	1	DAC5
0	1	1	0	DAC6
0	1	1	1	DAC7
1	X	X	X	ALL DACs

ed to reduce digital crosstalk. Issuing this command with DAC\_ADDRESS set to all DACs will update the CODE and DAC register contents of all DACs and is equivalent to CODE\_ALL\_LOAD\_ALL. Note this command by definition will modify at least one CODE register; to avoid this use the LOAD command with DAC\_ADDRESS set to all DACs or the LOAD\_ALL command.

### CODE\_ALL Command

The CODE\_ALL command (B[23:16] = 1100\_0000) updates the CODE register contents for all DACs.

### LOAD\_ALL Command

The LOAD\_ALL command (B[23:16] = 1100\_0001) updates the DAC register content for all DACs by uploading the current contents of the CODE registers to the DAC registers.

### CODE\_ALL\_LOAD\_ALL Command

The CODE\_ALL\_LOAD\_ALL command (B[23:16] = 1100\_0010) updates the CODE register contents for all DACs as well as the DAC register content of all DACs.

### RETURN\_ALL Command

The RETURN\_ALL command (B[23:16] = 1100\_0011) updates the RETURN register contents for all DACs.

### NO\_OP Commands Command

All unused commands in the space (B[23:16] = 1100\_X1XX or 1100\_1XXX) have no effect on the device, but will refresh the watchdog timer (if active) with the safety level set to low.

**WDOG Command**

The WDOG command (B[23:20] = 0001) updates the watchdog timeout settings and safety levels for the device. Timeout thresholds are selected in 1ms increments (1ms to 4095ms are available). The WD\_MASK bit can be used to mask the  $\overline{IRQ}$  operation in response to the watchdog status, if WD\_MASK = 1, watchdog alarms will not assert  $\overline{IRQ}$ . The watchdog alarm status (WD bit) can be polled using the available I<sup>2</sup>C status readback commands regardless of WD\_MASK settings. A write to this register will not reset a previously triggered watchdog alarm (use the WD\_RESET command for this purpose). The watchdog timer refresh and timeout behavior is defined by the programmable safety level below.

Available safety levels (WL[1:0]):

**Low (00):** Watchdog timer will refresh with the execution of any valid user mode command or no-op. Any successful slave address acknowledge qualifies to restart the watchdog timer (run to the ninth SCL edge), regardless of the command which follows. Issuing hardware  $\overline{CLR}$  or  $\overline{LDAC}$  falling edge will also refresh the watchdog timer. A triggered watchdog alarm does not prevent writes to

any register.  $\overline{LDAC}$  and  $\overline{CLR}$  inputs still function after a watchdog timeout event.

**Medium (01):** A WD\_REFRESH command must be executed in order to refresh the watchdog timer. Other commands as well as  $\overline{LDAC}$  or  $\overline{CLR}$  activity do not refresh the watchdog timer. A triggered watchdog alarm does not prevent writes to any register.  $\overline{LDAC}$  and  $\overline{CLR}$  inputs still function after a watchdog timeout event.

**High (10):** A WD\_REFRESH command must be executed to refresh the watchdog timer. Other commands as well as  $\overline{LDAC}$  or  $\overline{CLR}$  activity do not refresh the watchdog timer. A triggered watchdog alarm prevents execution of all POWER, REF, CONFIG, DEFAULT, and RETURN commands.  $\overline{LDAC}$  and  $\overline{CLR}$  inputs still function after a watchdog timeout event.

**Max (11):** A WD\_REFRESH command must be executed to refresh the watchdog timer. Other commands, as well as  $\overline{LDAC}$  or  $\overline{CLR}$  activity, do not refresh the watchdog timer. A triggered watchdog alarm prevents execution of all POWER, REF, CONFIG, DEFAULT, and RETURN commands.  $\overline{LDAC}$  and  $\overline{CLR}$  are gated and do not function after a watchdog timeout event.

**Table 6. WDOG Command Format**

B23	B22	B21	B20	B19	B18	B17	B16	B15	B14	B13	B12	B11	B10	B9	B8	B7	B6	B5	B4	B3	B2	B1	B0			
0	0	0	1	X	X	X	X	C11	C10	C9	C8	C7	C6	C5	C4	C3	C2	C1	C0	WDM	WL1	WL0	X			
WDOG Command				Don't Care				TIMEOUT SELECTION[11:4]								TIMEOUT SELECTION[3:0]				WD_MASK	WDOG Safety Level: 00: Low 01: Med 10: High 11: Max		Don't Care			
Default Value →								0	0	0	0	0	0	0	0	0	0	0	0	0	0	0	0	0	0	X
Command Byte								Data High Byte								Data Low Byte										

**Table 7. Watchdog Safety Level Protection**

WATCHDOG SAFETY LEVEL	ANY COMMAND REFRESHES WDT	$\overline{CLR}/\overline{LDAC}$ REFRESHES WDT	SW_RESET PLUS WD_RFRS REFRESHES WDT	ALL REGISTERS ACCESSIBLE AFTER WDT TIMEOUT*	$\overline{CLR}/\overline{LDAC}$ AFFECT DAC REGISTERS AFTER WDT TIMEOUT*
00 (Low)	X	X	X	X	X
01 (Med)	—	—	X	X	X
10 (High)	—	—	X	—	X
11 (Max)	—	—	X	—	—

\*Unless otherwise affected by Watchdog HOLD or  $\overline{CLR}$  configurations as set by the CONFIG command. See the CONFIG register definition for details.

### REF Command

The REF command (B[23:20] = 0010) updates the global reference setting used for all DAC channels. If an internal reference mode is selected, bit RF2 (B18) defines the reference power mode. If RF2 is set to zero (default), the reference will be powered down any time all DAC channels are powered down (i.e. the device is in STANDBY mode). If RF2 is set to one, the reference will remain powered even if all DAC channels are powered down, allowing continued operation of external circuitry (note in this mode the low current shutdown state is not available). This command is inaccessible when a watchdog timeout has occurred and the watchdog timer is configured with a safety level of high or max.

### SW\_GATE\_CLR Command

The SW\_GATE\_CLR command (B[23:0] = 0011\_0000\_1001\_0110\_0011\_0000) will remove any existing GATE condition initiated by a previous SW\_GATE\_SET command.

### SW\_GATE\_SET Command

The SW\_GATE\_SET command (B[23:0] = 0011\_0001\_1001\_0110\_0011\_0000) will initiate a GATE condition. Any DACs configured with GTB = 0 (see the [CONFIG Command](#) section) will have their outputs held at the selected DEFAULT value until the GATE condition is later removed by a subsequent SW\_GATE\_CLR command. While in gate mode, the CODE and DAC registers continue to function normally and are not reset (unless reset by a watchdog timeout).

### WD\_REFRESH Command

The WD\_REFRESH command (B[23:0] = 0011\_0010\_1001\_0110\_0011\_0000) will refresh the watchdog timer. This is the only command which will refresh the watchdog timer if the device is configured with a safety level of medium, high, or max. Use this command to prevent the watchdog timer from timing out.

### WD\_RESET Command

A WD\_RESET command (B[23:0] = 0011\_0011\_1001\_0110\_0011\_0000) will reset the watchdog interrupt (timeout) status and refresh the watchdog timer. Use this command to reset the  $\overline{IRQ}$  timeout condition after the watchdog timer has timed out. Any DACs impacted by an existing timeout condition will return to normal operation.

### SW\_CLEAR Command

A software clear command (B[23:0] = 0011\_0100\_001\_0110\_0011\_0000) will clear the contents of the CODE and DAC registers to the DEFAULT state for all channels configured with CLB = 0 (see CONFIG command).

### SW\_RESET Command

A software reset command (B[23:0] = 0011\_0101\_1001\_0110\_0011\_0000) will reset all CODE, DAC, and configuration registers to their defaults (including POWER, DEFAULT, CONFIG, WDOG, and REF registers), simulating a power-on reset.

**Table 8. REF Command Format**

B23	B22	B21	B20	B19	B18	B17	B16	B15	B14	B13	B12	B11	B10	B9	B8	B7	B6	B5	B4	B3	B2	B1	B0
0	0	1	0	0	RF2	RF1	RF0	X	X	X	X	X	X	X	X	X	X	X	X	X	X	X	X
REF Command				Reserved	0 = DAC Controlled 1 = Always ON	REF Mode: 00: EXT 01: 2.5V 10: 2.0V 11: 4.0V			Don't Care							Don't Care							
Default Value →					0	0	0	X	X	X	X	X	X	X	X	X	X	X	X	X	X	X	X
Command Byte								Data High Byte								Data Low Byte							

**POWER Command**

The POWER command (B[23:20] = 0100) updates the power mode settings of the selected DACs. DACs that are not selected do not update their power settings in response to the command. The new power setting is determined by bits PD[1:0] (B[7:6]) while the affected DAC(s) are selected using B[15:8]. If all DACs are powered down and the RF2 bit is not set, the device enters a STANDBY mode (all analog circuitry is disabled). This command is inaccessible when a watchdog timeout has

occurred and the watchdog timer is configured with a safety level of high or max.

Available power modes (PD[1:0]):

Normal (00): DAC channel is active (default),

PD 1kΩ (01): Power down with 1kΩ termination to GND,

PD 100kΩ (10): Power down with 100kΩ termination to GND,

PD Hi-Z (11): Power down with high-impedance output.

**Table 9. POWER Command Format**

B23	B22	B21	B20	B19	B18	B17	B16	B15	B14	B13	B12	B11	B10	B9	B8	B7	B6	B5	B4	B3	B2	B1	B0	
0	1	0	0	0	0	0	0	7	6	5	4	3	2	1	0	PD1	PD0	X	X	X	X	X	X	
POWER Command				Reserved				Multiple DAC Selection								Power Mode: 00 = Normal 01 = 1kΩ 10 = 100kΩ 11 = Hi-Z		Don't Care						
Default Value →								1	1	1	1	1	1	1	1	1	0	0	X	X	X	X	X	X
Command Byte								Data High Byte								Data Low Byte								

**CONFIG Command**

The CONFIG command (B[23:16] = 0101) updates the watchdog, gate, load, and clear mode settings of the selected DACs. DACs which are not selected do not update their settings in response to the command. The new mode settings to be written are determined by bits B[7:3] while the affected DAC(s) are selected by B[15:8]. This command is inaccessible when a watchdog timeout has occurred and the watchdog timer is configured with a safety level of high or max.

**Watchdog Configuration:**

WDOG Config settings are written by WC[1:0] (B[7:6]):

DISABLE (WC = 00): Watchdog timeout does not affect the operation of the selected DAC.

GATE (WC = 01): DAC code is gated to DEFAULT value in response to watchdog timeouts. Unless otherwise prohibited by the watchdog safety level,  $\overline{\text{LDAC}}$ ,  $\overline{\text{CLR}}$ ,

and write operations to the CODE and DAC registers are accepted but will not be reflected on the DAC output until the watchdog timeout status is reset.

$\overline{\text{CLR}}$  (WC = 10): CODE and DAC register contents are cleared to DEFAULT value in response to watchdog timeouts. All writes to CODE and DAC registers are ignored and  $\overline{\text{LDAC}}$  or  $\overline{\text{CLR}}$  input activity has no effect until the watchdog timeout status is reset, regardless of watchdog safety level.

HOLD (WC = 11): DAC code is held at its previously programmed value in response to watchdog time-out. All writes to DAC and CODE registers are ignored and  $\overline{\text{LDAC}}$  or  $\overline{\text{CLR}}$  input activity has no effect until the watchdog timeout status is reset, regardless of watchdog safety level.

**Note:** For the watchdog to timeout and have an impact, the function must first be enabled and configured using the WDOG command.

MAX5823/MAX5824/  
MAX5825

Ultra-Small, Octal Channel, 8-/10-/12-Bit  
Buffered Output DACs with Internal  
Reference and I<sup>2</sup>C Interface

**Gate Configuration:**

The DAC GATE setting is written by GTB (B5); GATE operation is as follows:

GTB = 0: Enables software gating function (default), DAC outputs are gated to their DEFAULT settings as long as the device remains in GATE mode (set by SW\_GATE\_SET and removed by SW\_GATE\_CLR).

GTB = 1: Disable software gating function, DAC outputs are not impacted by GATE mode.

**Load Configuration:**

The LDAC\_ENB setting is written by LDB (B4); LDAC\_ENB operation is as follows:

LDB = 0: DAC latch is operational, enabling  $\overline{\text{LDAC}}$  and LOAD functions (default).

LDB = 1: DAC latch is transparent, the CODE register content controls the DAC output directly.

**Clear Configuration:**

CLEAR\_ENB setting is written by CLB (B3); CLEAR\_ENB operation is as follows:

CLB = 0: Clear input and command functions impact the DAC (default), clearing CODE and DAC registers to their DEFAULT value.

CLB = 1: Clear input and command functions have no effect on the DAC.

**Table 10. CONFIG Command Format**

B23	B22	B21	B20	B19	B18	B17	B16	B15	B14	B13	B12	B11	B10	B9	B8	B7	B6	B5	B4	B3	B2	B1	B0
0	1	0	1	0	0	0	0	7	6	5	4	3	2	1	0	WC1	WC0	GTB	LDB	CLB	X	X	X
CONFIG Command				Reserved				Multiple DAC Selection								WDOG Config: 00: DISABLE 01: GATE 10: $\overline{\text{CLR}}$ 11: HOLD		GATE_ENB	LDAC_ENB	CLEAR_ENB	Don't Care		
Default Value →								1	1	1	1	1	1	1	1	0	0	0	0	0	X	X	X
Command Byte								Data High Byte								Data Low Byte							

**DEFAULT Command**

The DEFAULT command (B[23:20] = 0110) selects the default value for selected DACs. DACs which are not selected do not update their default settings in response to the command. These default values are used for all future watchdog, clear, and gate operations. The new default setting is determined by bits DF[2:0] (B[7:5]) while the affected DAC(s) are selected using B[15:8]. This command is inaccessible when a watchdog timeout has occurred and the watchdog timer is configured with a safety level of high or max. Note the selected default values do not apply to resets initiated by SW\_RESET commands or supply cycling, both of which return all DACs to the values determined by the M/ $\bar{Z}$  input and reset this register to M/ $\bar{Z}$  mode.

Available default values (DF[2:0]):

M/ $\bar{Z}$  (000): DAC channel defaults to value as selected by the M/ $\bar{Z}$  input (default).

ZERO (001): DAC channel defaults to zero scale.

MID (010): DAC channel defaults to midscale.

FULL (011): DAC channel defaults to full scale.

RETURN (100): DAC channel defaults to the value programmed by the RETURN command.

No Effect (101, 110, 111): DAC channel default behavior is unchanged.

**Table 11. DEFAULT Command Format**

B23	B22	B21	B20	B19	B18	B17	B16	B15	B14	B13	B12	B11	B10	B9	B8	B7	B6	B5	B4	B3	B2	B1	B0
0	1	1	0	0	0	0	0	7	6	5	4	3	2	1	0	DF2	DF1	DF0	X	X	X	X	X
DEFAULT Command				Reserved				Multiple DAC Selection								Default Values: 000: M/ $\bar{Z}$ 001: ZERO 010: MID 011: FULL 100: RETURN 101+: No Effect			Don't Care				
Default Value →								1	1	1	1	1	1	1	1	0	0	0	X	X	X	X	X
Command Byte								Data High Byte								Data Low Byte							

## Applications Information

### Power-On Reset (POR)

When power is applied to  $V_{DD}$  and  $V_{DDIO}$ , the DAC output is set to zero scale. To optimize DAC linearity, wait until the supplies have settled and the internal setup and calibration sequence completes (200 $\mu$ s, typ).

### Power Supplies and Bypassing Considerations

Bypass  $V_{DD}$  and  $V_{DDIO}$  with high-quality ceramic capacitors to a low-impedance ground as close as possible to the device. Minimize lead lengths to reduce lead inductance. Connect the GND to the analog ground plane.

### Layout Considerations

Digital and AC transient signals on GND can create noise at the output. Connect GND to form the star ground for the DAC system. Refer remote DAC loads to this system ground for the best possible performance. Use proper grounding techniques, such as a multilayer board with a low-inductance ground plane, or star connect all ground return paths back to the MAX5823/MAX5824/MAX5825 GND. Carefully layout the traces between channels to reduce AC cross-coupling. Do not use wire-wrapped boards and sockets. Use shielding to maximize noise immunity. Do not run analog and digital signals parallel to one another, especially clock signals. Avoid routing digital lines underneath the MAX5823/MAX5824/MAX5825 package.

## Definitions

### Integral Nonlinearity (INL)

INL is the deviation of the measured transfer function from a straight line drawn between two codes once offset and gain errors have been nullified.

### Differential Nonlinearity (DNL)

DNL is the difference between an actual step height and the ideal value of 1 LSB. If the magnitude of the DNL  $\leq$  1 LSB, the DAC guarantees no missing codes and is monotonic. If the magnitude of the DNL  $\geq$  1 LSB, the DAC output may still be monotonic.

### Offset Error

Offset error indicates how well the actual transfer function matches the ideal transfer function. The offset error is calculated from two measurements near zero code and near maximum code.

### Gain Error

Gain error is the difference between the ideal and the actual full-scale output voltage on the transfer curve, after nullifying the offset error. This error alters the slope of the transfer function and corresponds to the same percentage error in each step.

### Zero-Scale Error

Zero-scale error is the difference between the DAC output voltage when set to code zero and ground. This includes offset and other die level nonidealities.

### Full-Scale Error

Full-scale error is the difference between the DAC output voltage when set to full scale and the reference voltage. This includes offset, gain error, and other die level nonidealities.

### Settling Time

The settling time is the amount of time required from the start of a transition, until the DAC output settles to the new output value within the converter's specified accuracy.

### Digital Feedthrough

Digital feedthrough is the amount of noise that appears on the DAC output when the DAC digital control lines are toggled.

### Digital-to-Analog Glitch Impulse

A major carry transition occurs at the midscale point where the MSB changes from low to high and all other bits change from high to low, or where the MSB changes from high to low and all other bits change from low to high. The duration of the magnitude of the switching glitch during a major carry transition is referred to as the digital-to-analog glitch impulse. Although all bits change, larger steps may lead to larger glitch energy.

The digital-to-analog power-up glitch is the duration of the magnitude of the switching glitch that occurs as the device exits power-down mode.

Detailed Functional Diagram

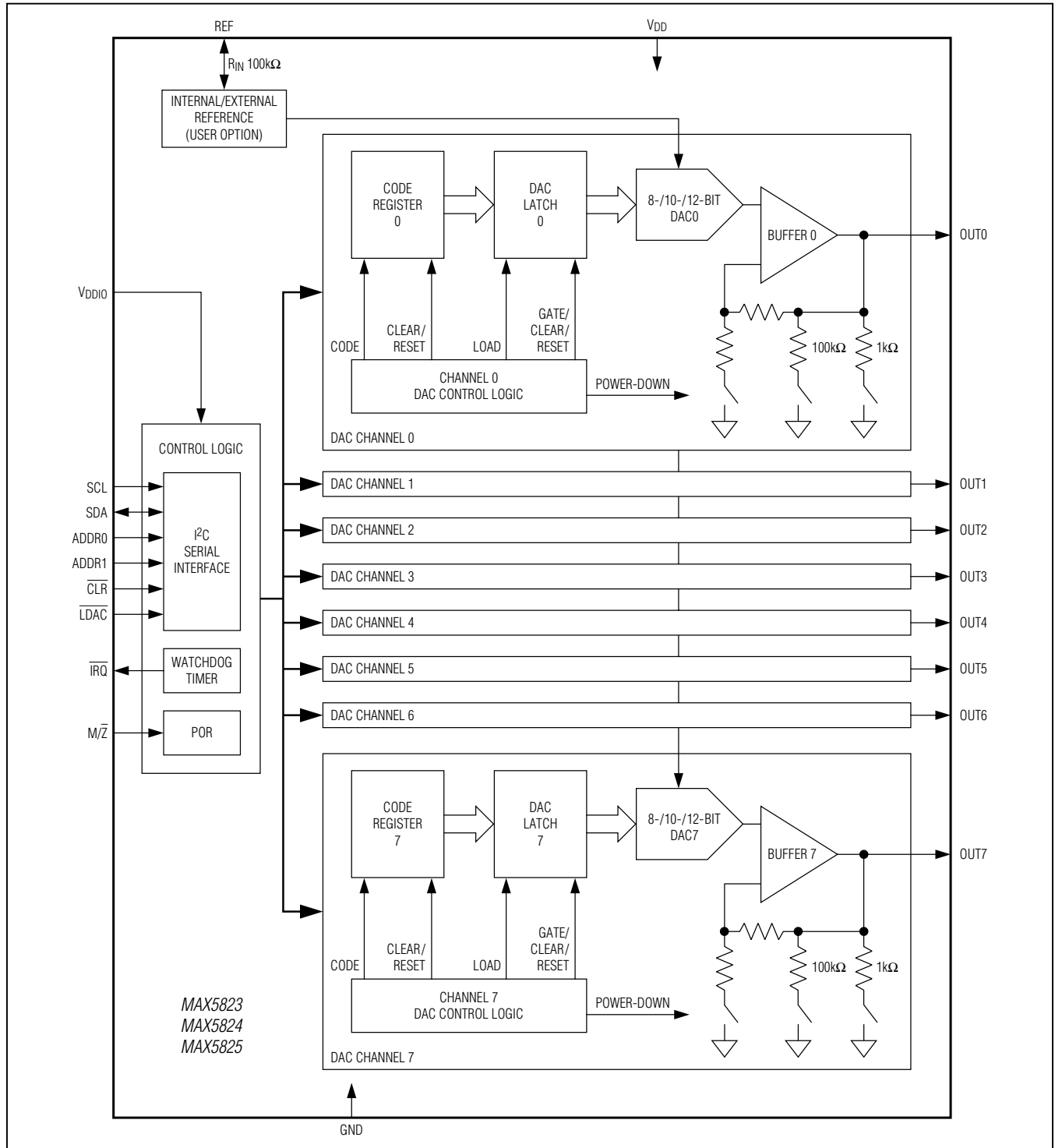

MAX5823/MAX5824/  
MAX5825

Ultra-Small, Octal Channel, 8-/10-/12-Bit  
Buffered Output DACs with Internal  
Reference and I<sup>2</sup>C Interface

Typical Operating Circuits

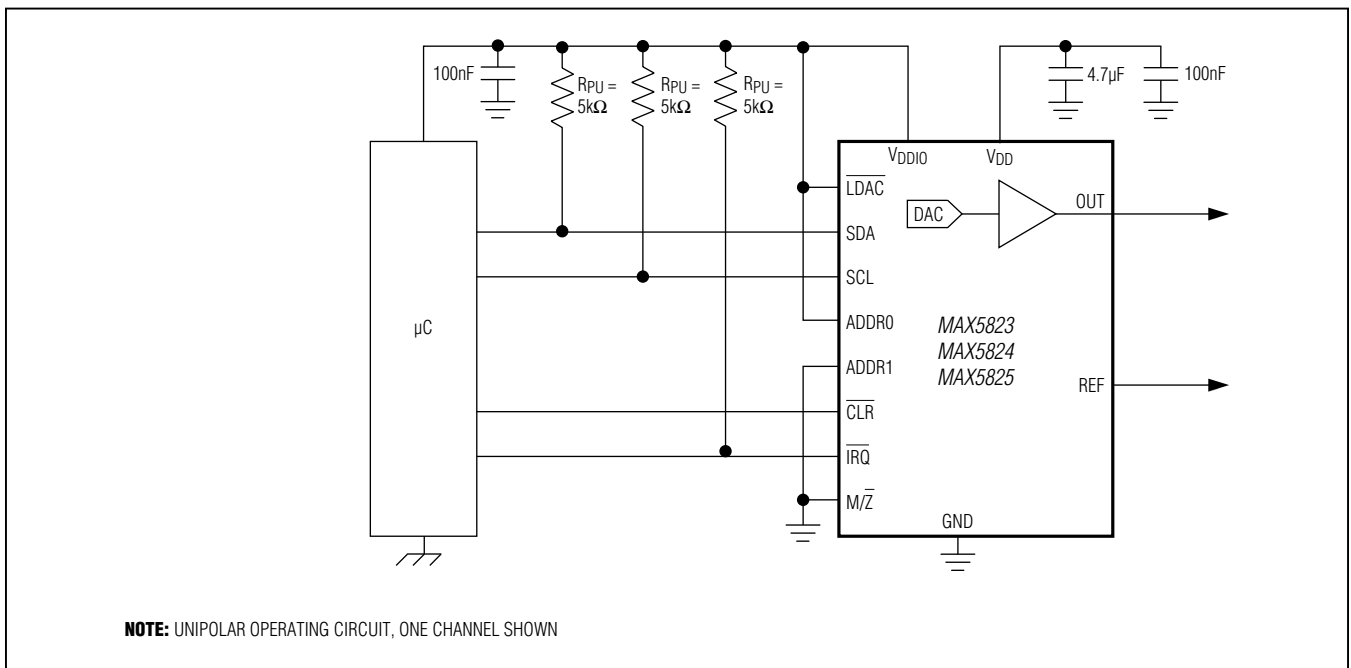
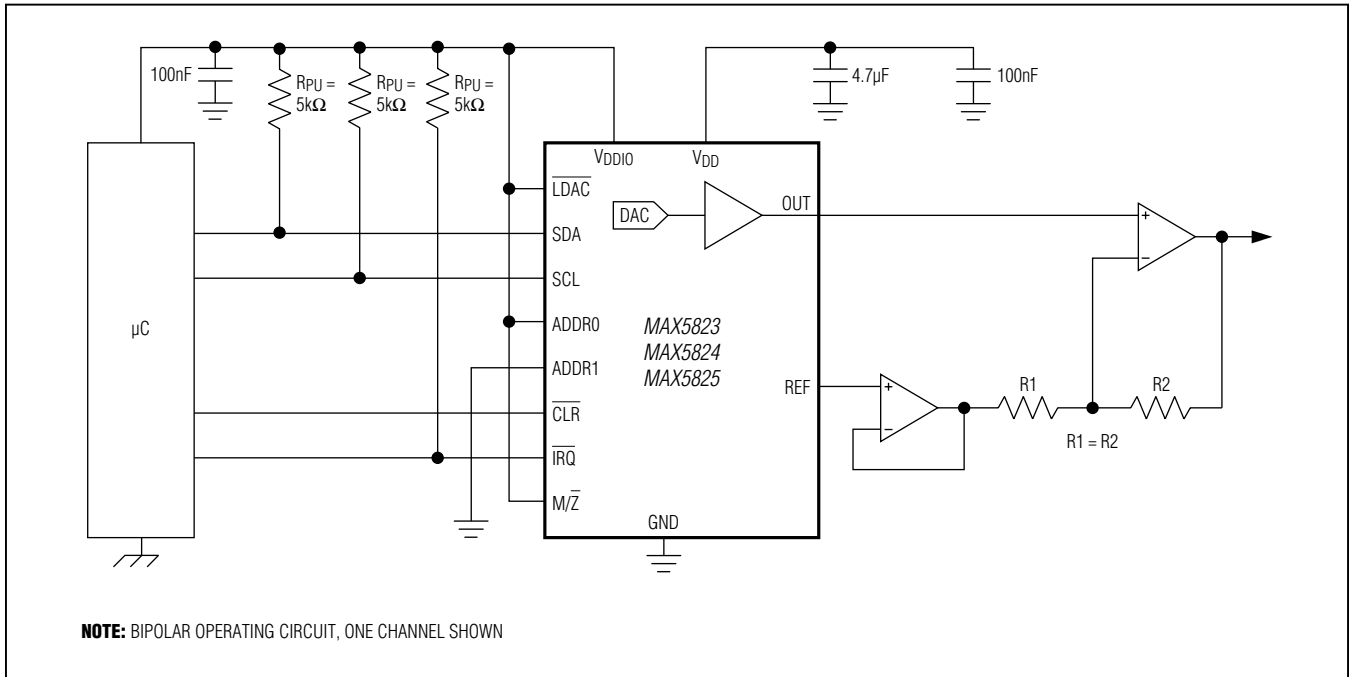

MAX5823/MAX5824/  
MAX5825

Ultra-Small, Octal Channel, 8-/10-/12-Bit  
Buffered Output DACs with Internal  
Reference and I<sup>2</sup>C Interface

## Ordering Information

PART	TEMPERATURE RANGE	PIN-PACKAGE	RESOLUTION (BIT)
MAX5823AUP+	-40°C to +125°C	20 TSSOP	8
MAX5823AWP+T	-40°C to +125°C	20 WLP	8
MAX5824AUP+	-40°C to +125°C	20 TSSOP	10
MAX5825AAUP+	-40°C to +125°C	20 TSSOP	12
MAX5825AWP+T	-40°C to +125°C	20 WLP	12
MAX5825BAUP+	-40°C to +125°C	20 TSSOP	12

**Note:** All devices are specified over the -40°C to +125°C temperature range.

+Denotes a lead(Pb)-free/RoHS-compliant package.

T = Tape and reel.

## Chip Information

PROCESS: BiCMOS

## Package Information

For the latest package outline information and land patterns (footprints), go to [www.maximintegrated.com/packages](http://www.maximintegrated.com/packages). Note that a "+", "#", or "-" in the package code indicates RoHS status only. Package drawings may show a different suffix character, but the drawing pertains to the package regardless of RoHS status.

PACKAGE TYPE	PACKAGE CODE	OUTLINE NO.	LAND PATTERN NO.
20 TSSOP	U20+1	<a href="#">21-0066</a>	<a href="#">90-0116</a>
20 WLP	W202C2+1	<a href="#">21-0059</a>	Refer to <a href="#">Application Note 1891</a>

## Revision History

REVISION NUMBER	REVISION DATE	DESCRIPTION	PAGES CHANGED
0	2/12	Initial release	—
1	11/12	Revised the <i>Electrical Characteristics</i> , <i>Ordering Information</i> , <i>Typical Operating Characteristics</i> , <i>Pin Configuration</i> , <i>Pin Description</i> , <i>CODEn_LOADn Command</i> , and <i>Offset Error</i> sections. Added the <i>Zero-Scale Error</i> and <i>Full-Scale Error</i> sections.	1, 3, 5, 7, 9–12, 14, 15, 25, 28–31, 34
2	2/13	Released the MAX5823/MAX5824/MAX5825B. Updated the <i>Electrical Characteristics</i> global and Note 3.	2–7, 35
3	8/19	Updated <i>Ordering Information</i> table	34

Maxim Integrated cannot assume responsibility for use of any circuitry other than circuitry entirely embodied in a Maxim Integrated product. No circuit patent licenses are implied. Maxim Integrated reserves the right to change the circuitry and specifications without notice at any time. The parametric values (min and max limits) shown in the *Electrical Characteristics* table are guaranteed. Other parametric values quoted in this data sheet are provided for guidance.

## Looking for pricing, stock, or lifecycle information?

Click below to explore more details on WIN SOURCE:

- ⊖ [View MAX5825AAUP+ on WIN SOURCE](#)
- ⊖ [Maxim Integrated Information](#)

## Optimize Your Supply Chain with WIN SOURCE Solutions

- ✓ Global Sourcing Solution
- ✓ Obsolete Management
- ✓ Cost Control Management
- ✓ Shortage Management
- ✓ Alternative Solution
- ✓ Excess Inventory Management