



**THE DATASHEET OF
LTC1382IN#PBF**



5V Low Power RS232 Transceiver with Shutdown

FEATURES

- Operates from a Single 5V Supply
- Low Supply Current: $I_{CC} = 220\mu\text{A}$
- $I_{CC} = 0.2\mu\text{A}$ in Shutdown Mode
- ESD Protection Over $\pm 10\text{kV}$
- Uses Small Capacitors: $0.1\mu\text{F}$
- Operates to 120kBaud
- Output Overvoltage Does Not Force Current Back into Supplies
- RS232 I/O Lines Can Be Forced to $\pm 25\text{V}$ Without Damage
- Pin Compatible with LT1180A

APPLICATIONS

- Notebook Computers
- Palmtop Computers

DESCRIPTION

The LTC[®]1382 is an ultra-low power 2-driver/2-receiver RS232 transceiver that operates from a single 5V supply. The charge pump requires only four space-saving $0.1\mu\text{F}$ capacitors.

The transceiver operates in one of two modes, Normal and Shutdown. In the Normal mode, I_{CC} is only $220\mu\text{A}$ with the driver outputs unloaded. In the Shutdown mode, the charge pump is turned off, the driver outputs are forced into three-state, both receivers are off and I_{CC} drops to $0.2\mu\text{A}$.

The LTC1382 is fully compliant with all data rate and overvoltage RS232 specifications. The transceiver can operate up to 120kbaud with a 2500pF , $3\text{k}\Omega$ load. Both driver outputs and receiver inputs can be forced to $\pm 25\text{V}$ without damage and can survive multiple $\pm 10\text{kV}$ ESD strikes.

LT, LTC and LT are registered trademarks of Linear Technology Corporation.

TYPICAL APPLICATION

2-Drivers/2-Receivers with Shutdown

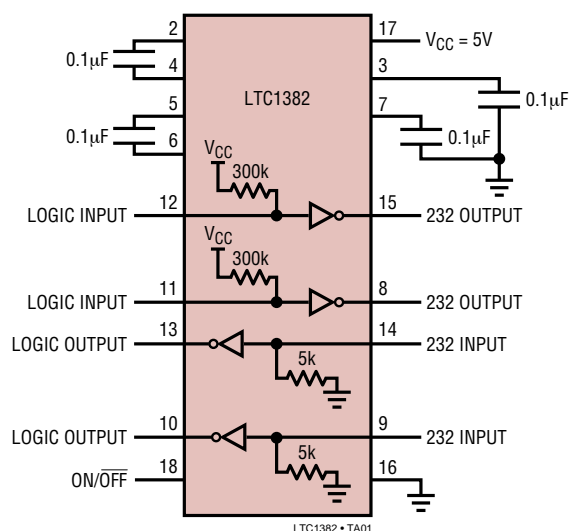

Quiescent and Shutdown Supply Current vs Temperature

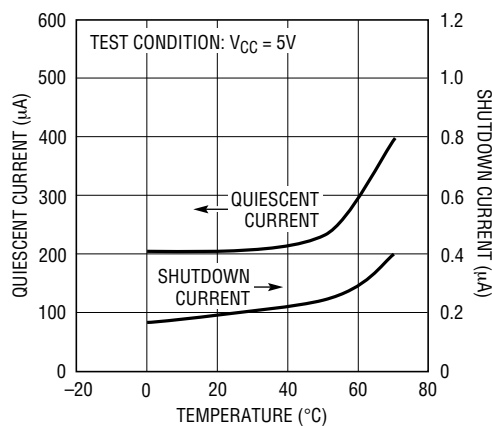

LTC1382 - TA02

ABSOLUTE MAXIMUM RATINGS

Supply Voltage (V_{CC})	6V
Input Voltage	
Driver	-0.3V to $V_{CC} + 0.3V$
Receiver	-25V to 25V
Digital Input	-0.3V to $V_{CC} + 0.3V$
Output Voltage	
Driver	-25V to 25V
Receiver	-0.3V to $V_{CC} + 0.3V$
Short-Circuit Duration	
V^+	30 sec
V^-	30 sec
Driver Output	Indefinite
Receiver Output	Indefinite
Operating Temperature Range	
LTC1382C	0°C to 70°C
LTC1382I	-40°C to 85°C
Storage Temperature Range	-65°C to 150°C
Lead Temperature (Soldering, 10 sec)	300°C

PACKAGE/ORDER INFORMATION

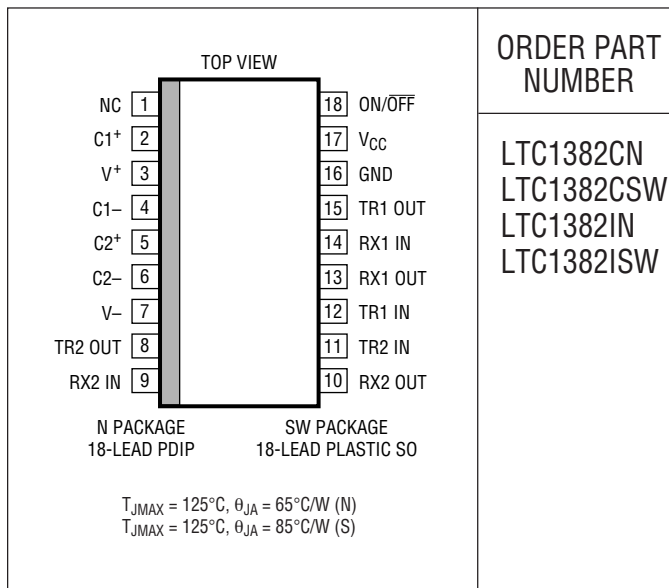

ORDER PART NUMBER

- LTC1382CN
- LTC1382CSW
- LTC1382IN
- LTC1382ISW

Consult LTC Marketing for parts specified with wider operating temperature ranges.

DC ELECTRICAL CHARACTERISTICS

The ● denotes specifications which apply over the full operating temperature range. $V_{CC} = 5V$, $C1 = C2 = C3 = C4 = 0.1\mu F$, $V_{ON/OFF} = V_{CC}$, unless otherwise noted.

PARAMETER	CONDITIONS	MIN	TYP	MAX	UNITS		
Any Driver							
Output Voltage Swing	3k to GND	Positive Negative	● ●	5.0 -5.0	7.0 -6.5	V V	
Logic Input Voltage Level	Input Low Level ($V_{OUT} = High$) Input High Level ($V_{OUT} = Low$)	● ●	● ●	2.0	1.4 1.4	0.8 V V	
Logic Input Current	$V_{IN} = V_{CC}$ $V_{IN} = 0V$	● ●	●		-20	5 -40	μA μA
Output Short-Circuit Current	$V_{OUT} = 0V$			±9	±12	mA	
Output Leakage Current	Shutdown or $V_{CC} = 0V$ (Note 3), $V_{OUT} = \pm 10V$	●			±10	±500	μA
Any Receiver							
Input Voltage Thresholds	Input Low Threshold Input High Threshold	● ●	●	0.8	1.3 1.7	2.4	V V
Hysteresis		●		0.1	0.4	1	V
Input Resistance	$-10V \leq V_{IN} \leq 10V$			3	5	7	kΩ
Output Voltage	Output Low, $I_{OUT} = -1.6mA$ ($V_{CC} = 5V$) Output High, $I_{OUT} = 160\mu A$ ($V_{CC} = 5V$)	● ●			0.2	0.4	V V
Output Short-Circuit Current	Sinking Current, $V_{OUT} = V_{CC}$ Sourcing Current $V_{OUT} = 0V$			-15	-40		mA mA
Output Leakage Current	Shutdown (Note 3), $0V \leq V_{OUT} \leq V_{CC}$	●			1	10	μA

DC ELECTRICAL CHARACTERISTICS The ● denotes specifications which apply over the full operating temperature range. $V_{CC} = 5V$, $C1 = C2 = C3 = C4 = 0.1\mu F$, $V_{ON/OFF} = V_{CC}$, unless otherwise noted.

PARAMETER	CONDITIONS	MIN	TYP	MAX	UNITS
Power Supply Generator					
V ⁺ Output Voltage	$I_{OUT} = 0mA$		8.0		V
	$I_{OUT} = 8mA$		7.5		V
V ⁻ Output Voltage	$I_{OUT} = 0mA$		-8.0		V
	$I_{OUT} = -8mA$		-7.0		V
Supply Rise Time	Shutdown to Turn-On		0.2		ms
Power Supply					
V _{CC} Supply Current	No Load (Note 2), 0°C to 70°C	●	0.22	0.5	mA
	No Load (Note 2), -40°C to 85°C	●	0.35	1.0	mA
Supply Leakage Current (V _{CC})	Shutdown (Note 3)	●	0.2	10	μA
Digital Input Threshold Low		●	1.4	0.8	V
Digital Input Threshold High		●	2.0	1.4	V

AC CHARACTERISTICS The ● denotes specifications which apply over the full operating temperature range. $V_{CC} = 5V$, $C1 = C2 = C3 = C4 = 0.1\mu F$, unless otherwise noted.

PARAMETER	CONDITIONS	MIN	TYP	MAX	UNITS
Slew Rate	$R_L = 3k$, $C_L = 51pF$		8	30	V/μS
	$R_L = 3k$, $C_L = 2500pF$	3	5		V/μS
Driver Propagation Delay (TTL to RS232)	t_{HLD} (Figure 1)	●	2	3.5	μS
	t_{LHD} (Figure 1)	●	2	3.5	μS
Receiver Propagation Delay (RS232 to TTL)	t_{HLR} (Figure 2)	●	0.3	0.8	μS
	t_{LHR} (Figure 2)	●	0.3	0.8	μS

Note 1: Absolute Maximum Ratings are those values beyond which the life of the device may be impaired.

Note 3: Measurements made in the Shutdown mode are performed with $V_{ON/OFF} = 0V$.

Note 2: Supply current is measured with driver and receiver outputs unloaded.

TYPICAL PERFORMANCE CHARACTERISTICS

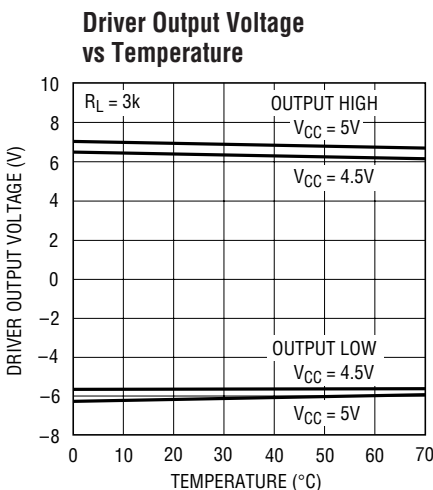

LTC1382 • TPC01

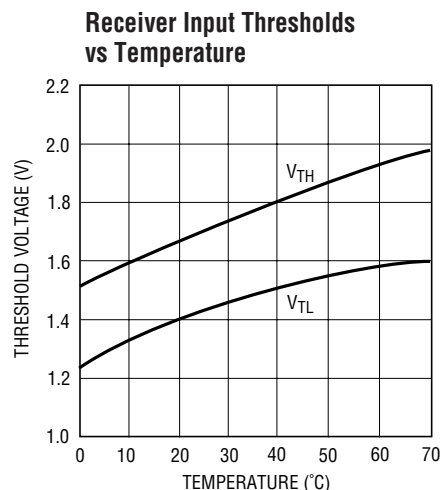

LTC1382 • TPC02

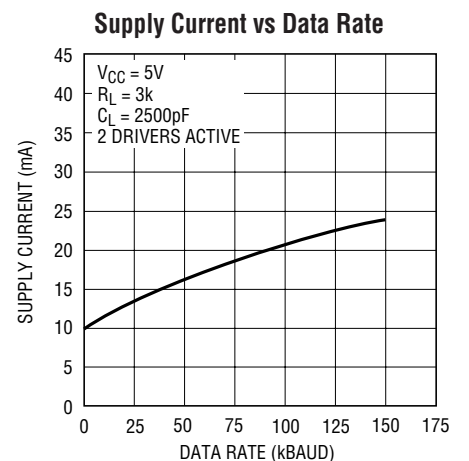

LTC1382 • TPC03

TYPICAL PERFORMANCE CHARACTERISTICS

V_{CC} Supply Current vs Temperature

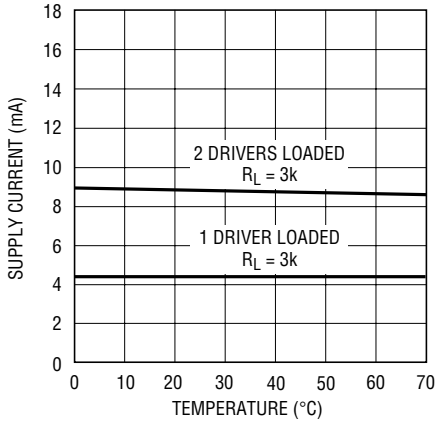

LTC1382 • TPC04

Driver Short-Circuit Current vs Temperature

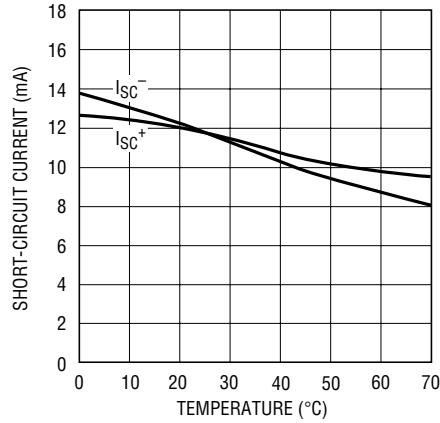

LTC1382 • TPC05

Receiver Short-Circuit Current vs Temperature

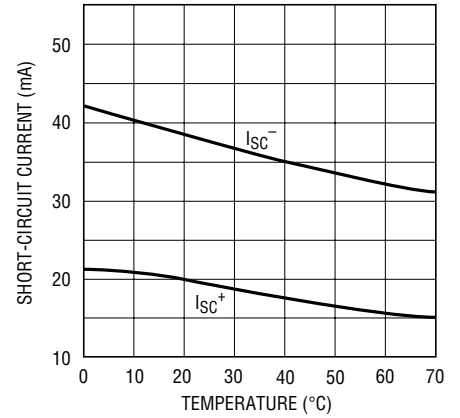

LTC1382 • TPC06

Driver Leakage in Shutdown vs Temperature

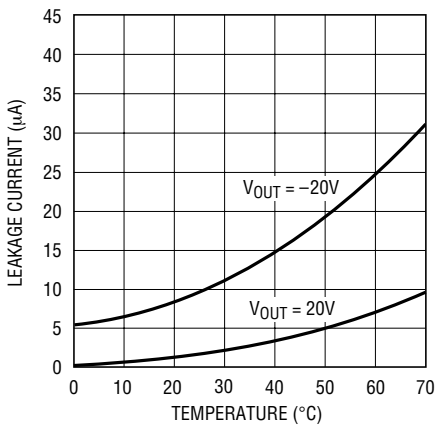

LTC1349 • TPC05

Driver Output Waveforms

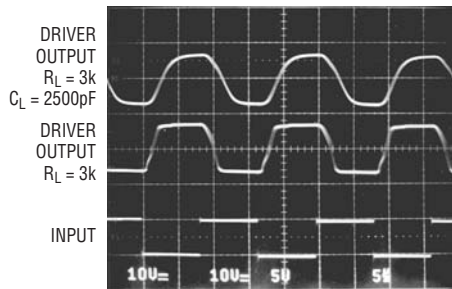

LTC1382 • TPC08

Receiver Output Waveforms

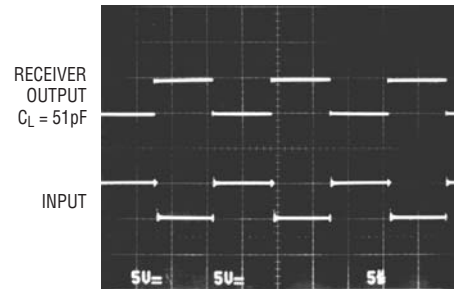

LTC1382 • TPC09

PIN FUNCTIONS

V_{CC}: 5V Input Supply Pin. This pin should be decoupled with a 0.1μF ceramic capacitor.

GND: Ground Pin.

ON/OFF: TTL/CMOS Compatible Shutdown Pin. A logic low puts the device in the Shutdown mode. Both driver outputs are forced into three-state and the supply current is 0.2μA.

V⁺: Positive Supply Output (RS232 Drivers). $V^+ \cong 2V_{CC} - 2V$. This pin requires an external capacitor $C = 0.1\mu F$ for charge storage. The capacitor may be tied to ground or V_{CC} . With multiple devices, the V^+ and V^- pins may share a common capacitor. For large numbers of devices, increasing the size of the shared common storage capacitors is recommended to reduce ripple.

V⁻: Negative Supply Output (RS232 Drivers). $V^- \cong -(2V_{CC} - 2V)$. This pin requires an external capacitor $C = 0.1\mu F$ for charge storage.

C1⁺, C1⁻, C2⁺, C2⁻: Commutating Capacitor Inputs. These pins require two external capacitors $C = 0.1\mu F$: one from C1⁺ to C1⁻ and another from C2⁺ to C2⁻. To maintain

charge pump efficiency, the capacitor's effective series resistance should be less than 2Ω.

TR IN: RS232 Driver Input Pins. Inputs are TTL/CMOS compatible. The inputs of unused drivers can be left unconnected since 300k input pull-up resistors to V_{CC} are included on chip. To minimize power consumption, the internal driver pull-up resistors are disconnected from V_{CC} in the Shutdown mode.

TR OUT: Driver Outputs at RS232 Voltage Levels. Outputs are in a high impedance state when in the Shutdown or $V_{CC} = 0V$. The driver outputs are protected against ESD to ±10kV for human body model discharges.

RX IN: Receiver Inputs. These pins can be forced to ±25V without damage. The receiver inputs are protected against ESD to ±10kV for human body model discharges. Each receiver provides 0.4V of hysteresis for noise immunity.

RX OUT: Receiver Outputs with TTL/CMOS Voltage Levels. Outputs are in a high impedance state when in the Shutdown mode.

SWITCHING TIME WAVEFORMS

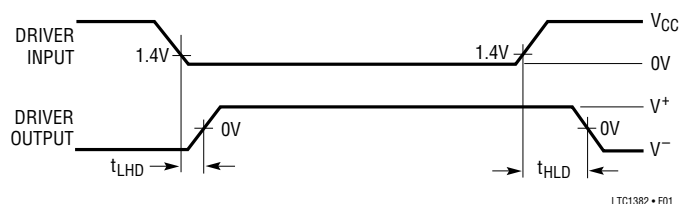

Figure 1. Driver Propagation Delay Timing

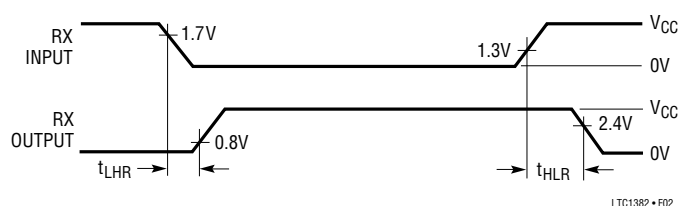
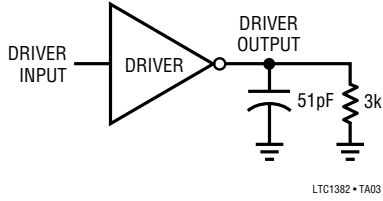

Figure 2. Receiver Propagation Delay Timing

TEST CIRCUITS

Driver Timing Test Load



Receiver Timing Test Load

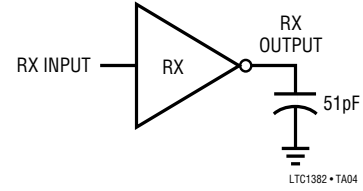

ESD Test Circuit

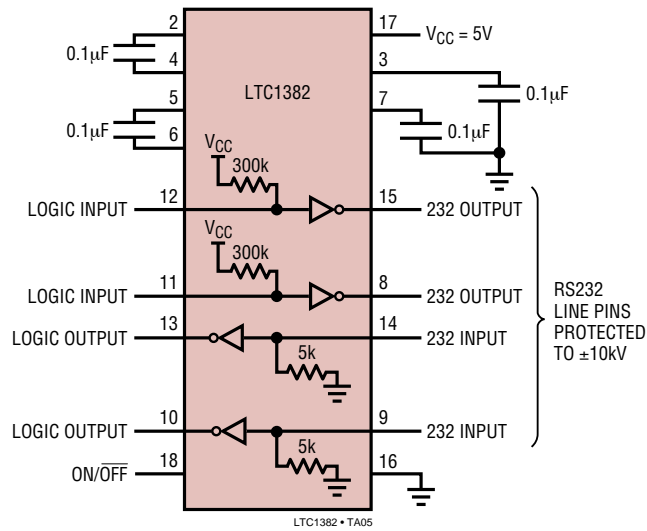

PACKAGE DESCRIPTION

N Package 18-Lead PDIP (Narrow .300 Inch) (Reference LTC DWG # 05-08-1510)

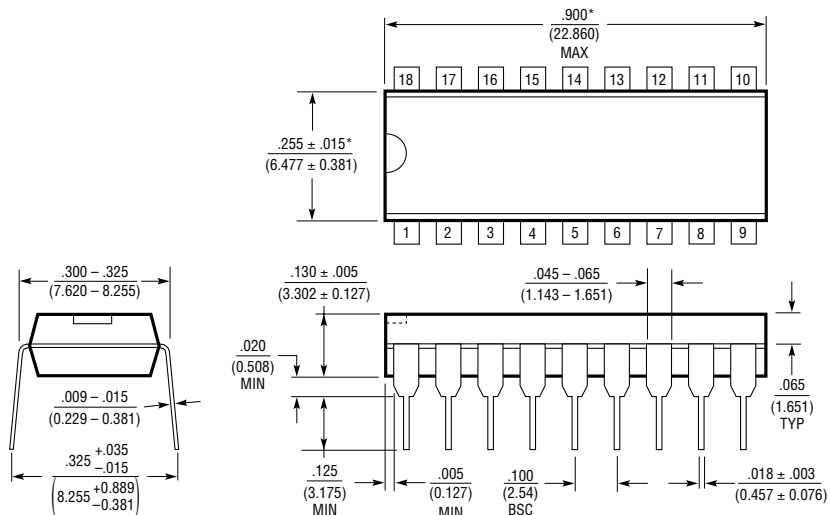

NOTE:
1. DIMENSIONS ARE IN INCHES
MILLIMETERS
*THESE DIMENSIONS DO NOT INCLUDE MOLD FLASH OR PROTRUSIONS.
MOLD FLASH OR PROTRUSIONS SHALL NOT EXCEED .010 INCH (0.254mm)

N18 0502

SW Package 18-Lead Plastic Small Outline (Wide .300 Inch) (Reference LTC DWG # 05-08-1620)

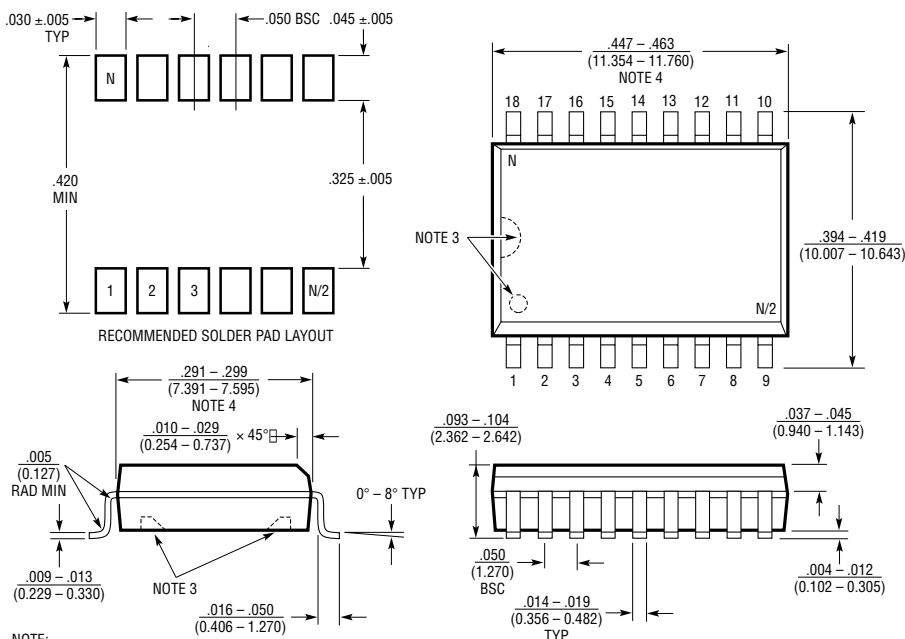

NOTE:
1. DIMENSIONS IN INCHES
(MILLIMETERS)
2. DRAWING NOT TO SCALE
3. PIN 1 IDENT, NOTCH ON TOP AND CAVITIES ON THE BOTTOM OF PACKAGES ARE THE MANUFACTURING OPTIONS.
THE PART MAY BE SUPPLIED WITH OR WITHOUT ANY OF THE OPTIONS
4. THESE DIMENSIONS DO NOT INCLUDE MOLD FLASH OR PROTRUSIONS.
MOLD FLASH OR PROTRUSIONS SHALL NOT EXCEED .006" (0.15mm)

S18 (WIDE) 0502



LTC1382

RELATED PARTS

PART NUMBER	DESCRIPTION	COMMENTS
LT1780/LT1781	5V, 2 Driver, 2 Receiver RS232 Transceivers	±15kV ESD per IEC 1000-4
LTC1383	5V, 2 Driver, 2 Receiver RS232 Transceiver	220µA Supply Current, Narrow 16-pin SO
LTC1384	5V, 2 Driver, 2 Receiver RS232 Transceiver	220µA Supply Current, 2 Receivers Active in Shutdown
LTC1385	3.3V, 2 Driver, 2 Receiver RS562 Transceiver	220µA Supply Current, 2 Receivers Active in Shutdown
LTC1386	3.3V, 2 Driver, 2 Receiver RS562 Transceiver	220µA Supply Current, Narrow 16-pin SO

Looking for pricing, stock, or lifecycle information?

Click below to explore more details on WIN SOURCE:

-  [View LTC1382IN#PBF on WIN SOURCE](#)
-  [Analog Devices Inc. Information](#)

Optimize Your Supply Chain with WIN SOURCE Solutions

-  Global Sourcing Solution
-  Obsolete Management
-  Cost Control Management
-  Shortage Management
-  Alternative Solution
-  Excess Inventory Management