



**THE DATASHEET OF
DC1316A**



3.5A, 25V Step-down Switching Regulator with SYNC Function

DESCRIPTION

Demonstration circuit 1316 is a monolithic step-down DC/DC switching regulator featuring LT1913. The LT1913 can be synchronized over a 250 KHz to 2 MHz range. The demo board is designed for 5V output from a 6.5V to 25V input. The wide input range of the LT1913 allows a variety of input sources. The typical sources are automotive batteries, wall adaptors and industrial supplies.

An optional EMC filter at the input is provided on the bottom of the board, which greatly reduces the conductive EMI noise at the input side. Customers can use this optional circuit by cutting the input trace on the bottom of the board and install the components. The current mode control scheme creates fast transient response and good loop stability. The gate drive of the internal switch is boosted to a voltage that is higher than the V_{in} to ensure saturation of the switch. The LT1913's integrated boost diode reduces the parts count. The

RUN/SS pin can be used to set the part in micro-power shutdown mode, reducing the supply current to less than 1uA. The RUN/SS pin can also be used to program soft start. In this mode, the RUN/SS pin is driven through an external RC filter to create a voltage ramp on this pin. The soft start function reduces the input current surge during start-up.

The LT1913 datasheet gives a complete description of the part, operation and application information. The datasheet must be read in conjunction with this quick start guide for demo circuit 1316.

Note: It is best to ground the SYNC pin if the SYNC function is not being used.

Design files for this circuit board are available. Call the LTC factory.

LT, LTC and LT are registered trademarks of Linear Technology Corporation. ThinSOT and PowerPath are trademarks of Linear Technology Corporation.

Performance Summary for Step-down Switching Regulator ($T_A = 25^{\circ}C$)

PARAMETER FOR BUCK REGULATOR	CONDITION	VALUE
Minimum Input Voltage		6.5V
Maximum Input Voltage		25V
Output Voltage V_{OUT}		5V +/- 4%
Maximum Output Current		3.5A
Typical Switching Frequency		800kHz

QUICK START PROCEDURE

Demonstration circuit 1316 is easy to set up to evaluate the performance of the LT1913. Refer to Figure 1 for proper measurement equipment setup and follow the procedure below:

NOTE. When measuring the input or output voltage ripple, care must be taken to avoid a long ground lead on the oscilloscope probe. Measure the input or output voltage ripple by touching the probe tip directly across the V_{in} or V_{out} and GND terminals. See Figure 2 for proper scope probe technique.

LT1913

1. Place JP1 on the RUN position.
2. With power off, connect the input power supply to Vin and GND.
3. Turn on the power at the input.
4. Check for the proper output voltage.

NOTE. If there is no output, temporarily disconnect the load to make sure that the load is not set too high.

5. Once the proper output voltage is established, adjust the load within the operating range and observe the output voltage regulation, ripple voltage, efficiency and other parameters.
6. An external clock can be added to the SYNC pin when SYNC function is used. See synchronization section in the datasheet for details.

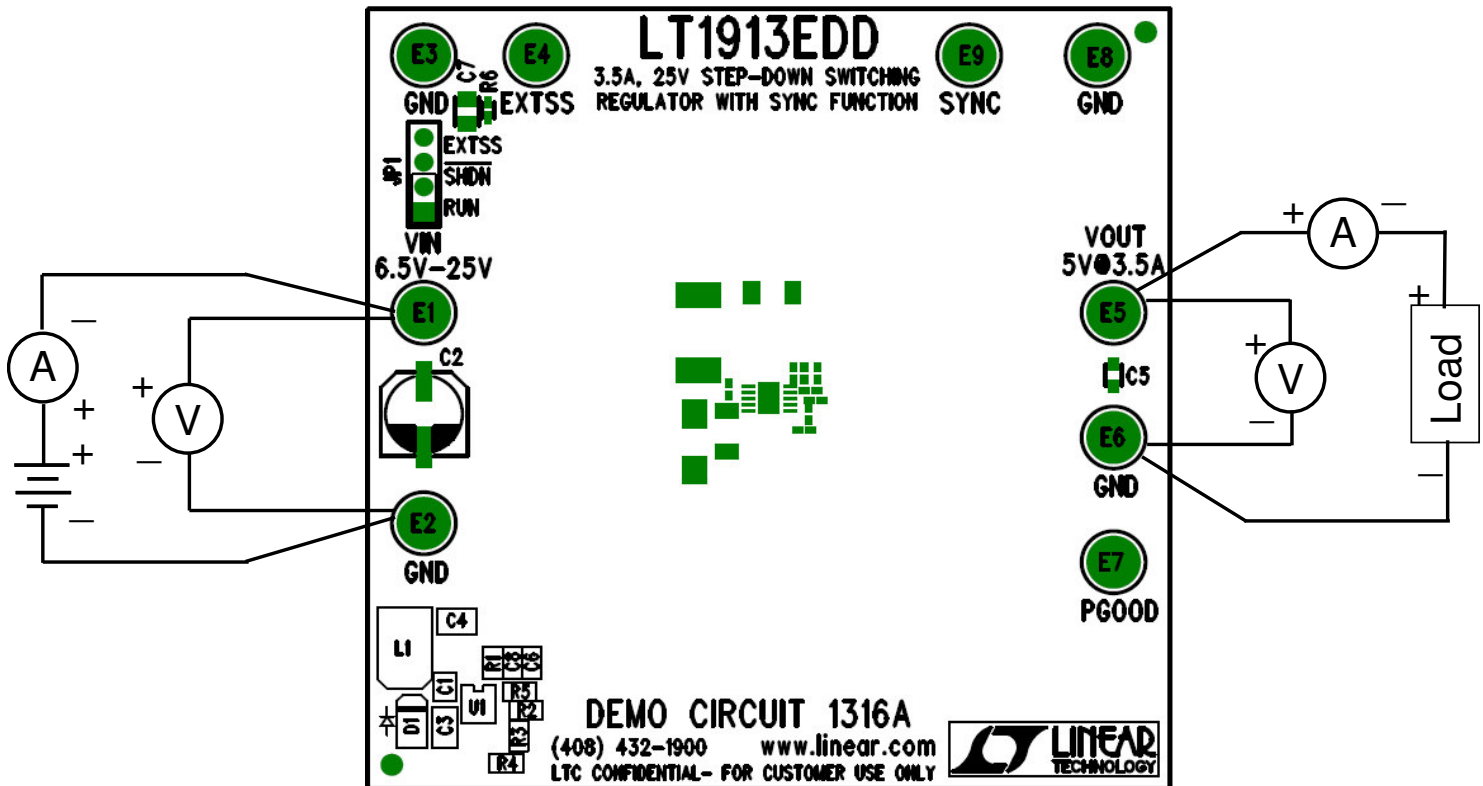

Figure 1. Proper Measurement Equipment Setup

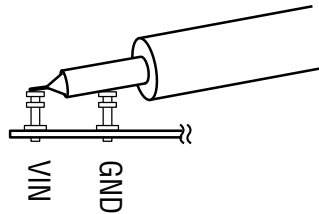

Figure 2. Measuring Input or Output Ripple

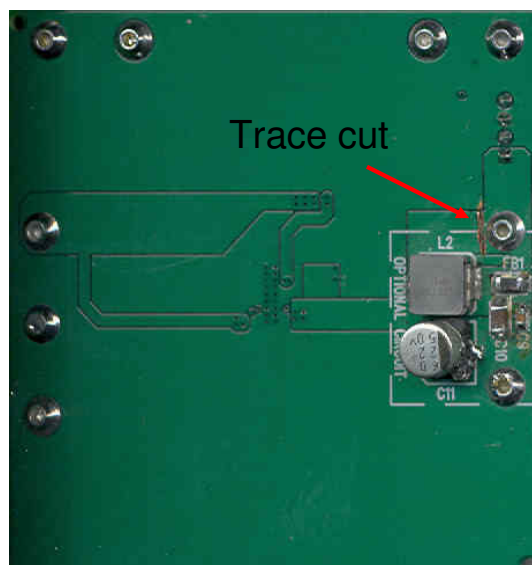
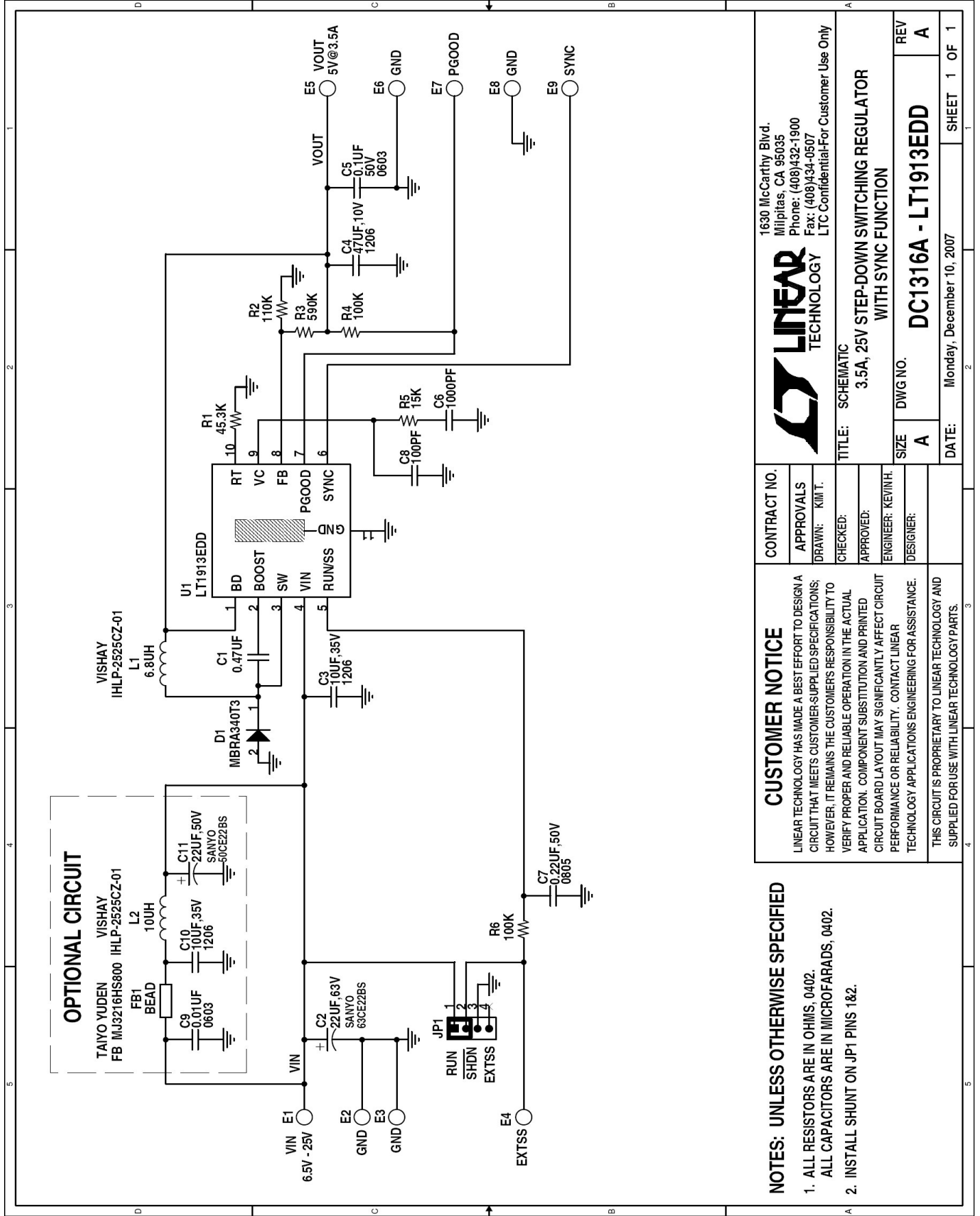

Figure 3. The Bottom of the demo Board with the Optional Circuit and the Input Trace Cut



LINEAR TECHNOLOGY

1630 McCarthy Blvd.
 Milpitas, CA 95035
 Phone: (408)432-1900
 Fax: (408)434-0507
 LTC Confidential-For Customer Use Only

CONTRACT NO.

APPROVALS
 DRAWN: KIM T.
 CHECKED:
 APPROVED:
 ENGINEER: KEVIN H.
 DESIGNER:

TITLE: SCHEMATIC
3.5A, 25V STEP-DOWN SWITCHING REGULATOR WITH SYNC FUNCTION

SIZE: A
DWG NO.: DC1316A - LT1913EDD
REV: A

DATE: Monday, December 10, 2007
SHEET: 1 OF 1

CUSTOMER NOTICE

LINEAR TECHNOLOGY HAS MADE A BEST EFFORT TO DESIGN A CIRCUIT THAT MEETS CUSTOMER-SUPPLIED SPECIFICATIONS; HOWEVER, IT REMAINS THE CUSTOMER'S RESPONSIBILITY TO VERIFY PROPER AND RELIABLE OPERATION IN THE ACTUAL APPLICATION. COMPONENT SUBSTITUTION AND PRINTED CIRCUIT BOARD LAYOUT MAY SIGNIFICANTLY AFFECT CIRCUIT PERFORMANCE OR RELIABILITY. CONTACT LINEAR TECHNOLOGY APPLICATIONS ENGINEERING FOR ASSISTANCE.

THIS CIRCUIT IS PROPRIETARY TO LINEAR TECHNOLOGY AND SUPPLIED FOR USE WITH LINEAR TECHNOLOGY PARTS.

NOTES: UNLESS OTHERWISE SPECIFIED

- ALL RESISTORS ARE IN OHMS, 0402.
- ALL CAPACITORS ARE IN MICROFARADS, 0402.
- INSTALL SHUNT ON JP1 PINS 1&2.

Looking for pricing, stock, or lifecycle information?

Click below to explore more details on WIN SOURCE:

 [View DC1316A on WIN SOURCE](#)

 [Analog Devices Inc. Information](#)

Optimize Your Supply Chain with WIN SOURCE Solutions

-  Global Sourcing Solution
-  Obsolete Management
-  Cost Control Management
-  Shortage Management
-  Alternative Solution
-  Excess Inventory Management