



**THE DATASHEET OF
S70GL02GS12FHIV20**



2 Gbit (256 MB) GL-S MIRRORBIT™ Flash

Parallel, 3.0 V

General description

The S70GL02GS 2-Gb MIRRORBIT™ flash memory device is fabricated on 65-nm MIRRORBIT™ process technology. This device offers a fast page access time of 25 ns with a corresponding random access time of 110 ns. It features a write buffer that allows a maximum of 256 words/512 bytes to be programmed in one operation, resulting in faster effective programming time than standard single byte/word programming algorithms. This makes the device an ideal product for today's embedded applications that require higher density, better performance and lower power consumption.

This document contains information for the S70GL02GS device, which is a dual die stack of two S29GL01GS die. For detailed specifications, please refer to the discrete die datasheet.

Document	Document number
S29GL01GS datasheet	001-98285

Distinctive characteristics

- CMOS 3.0 V core with Versatile I/O™
- Two 1024 Megabit (S29GL01GS) in a single 64-ball Fortified-BGA package (see [S29GL01GS datasheet](#) for full specifications)
- 65-nm MIRRORBIT™ process technology
- Single supply (V_{CC}) for read / program / erase (2.7 V to 3.6 V)
- Versatile I/O feature
 - Wide I/O voltage (VIO): 1.65 V to V_{CC}
- ×16 data bus
- 16-word/32-byte page read buffer
- 512-byte programming buffer
 - Programming in page multiples, up to a maximum of 512 bytes
- Sector erase
 - Uniform 128-KB sectors
 - S70GL02GS: two thousand forty-eight sectors
- Suspend and Resume commands for Program and Erase operations
- Status Register, data polling, and Ready/Busy pin methods to determine device status
- Advanced sector protection (ASP)
 - Volatile and non-volatile protection methods for each sector
- Separate 1024-byte one time program (OTP) array with two lockable regions
 - Available in each device Support for common flash interface (CFI)
- WP# input
 - Protects first or last sector, or first and last sectors of each device, regardless of sector protection settings

2 Gbit (256 MB) GL-S MIRRORBIT™ Flash Parallel, 3.0 V



Performance characteristics

- Temperature range:
 - Industrial temperature range (-40°C to +85°C)
 - Automotive AEC-Q100 grade 3 (-40°C to +85°C)
 - Automotive AEC-Q100 grade 2 (-40°C to +105°C)
- 100,000 erase cycles per sector typical
- 20-year data retention typical
- Packaging options
 - 64-ball LSH Fortified BGA, 13 mm × 11 mm

Performance characteristics

Maximum read access times (ns) ^[1]

Parameter	2 Gb	
Random access time (t_{ACC})	110	120
Page access time (t_{PACC})	20	30
CE# access time (t_{CE})	110	120
OE# access time (t_{OE})	25	35

Typical program and erase rates

Operation	Rate
Buffer Programming (512 bytes)	1.5 MBps
Sector Erase (128 kbytes)	477 KBps

Maximum current consumption

Operation	Current
Active read at 5 MHz, 30 pF	60 mA
Program	100 mA
Erase	100 mA
Standby	200 μ A

Notes

1. Access times are dependent on V_{IO} operating ranges. See [“Ordering information”](#) on page 21 for further details.
2. Contact Infineon sales representative for availability.

Table of contents

General description	1
Distinctive characteristics	1
Performance characteristics	2
Table of contents	3
1 Input/output description and logic symbol	4
2 Block diagrams	5
3 Connection diagrams	7
3.1 Special handling instructions for BGA package	7
4 Memory map	8
5 Second die access	9
6 Autoselect	10
7 Electrical specifications	11
7.1 Thermal resistance	11
8 DC characteristics	12
9 BGA package capacitance	13
10 Device ID and common flash interface (ID-CFI) ASO map	14
11 Package diagram	20
11.1 LSH064 — 64-ball fortified ball grid array, 13 x 11 mm	20
12 Ordering information	21
12.1 Recommended combinations	21
Revision history	23

1 Input/output description and logic symbol

Table 1 identifies the input and output package connections provided on the device.

Table 1 Input/output description

Symbol	Type	Description
A26–A0	Input	Address lines for GL02GS.
DQ15–DQ0	I/O	Data input/output.
CE#	Input	Chip Enable.
OE#	Input	Output Enable.
WE#	Input	Write Enable.
V _{CC}	Supply	Device power supply.
V _{IO}	Supply	Versatile IO input.
V _{SS}	Supply	Ground.
RY/BY#	Output	Ready/Busy. Indicates whether an Embedded Algorithm is in progress or complete. At V _{IL} , the device is actively erasing or programming. At High Z, the device is in ready.
RESET#	Input	Hardware Reset. LOW = device resets and returns to reading array data.
WP#	Input	Write Protect/Acceleration Input. At V _{IL} , disables program and erase functions in the outermost sectors. At V _{HH} , accelerates programming; automatically places device in unlock bypass mode. Should be at V _{IH} for all other conditions.
NC	No Connect	Not Connected. No device internal signal is connected to the package connector nor is there any future plan to use the connector for a signal. The connection may safely be used for routing space for a signal on a printed circuit board (PCB).
DNU	Reserved	Do Not Use. A device internal signal may be connected to the package connector. The connection may be used by Infineon for test or other purposes and is not intended for connection to any host system signal. Any DNU signal related function will be inactive when the signal is at V _{IL} . The signal has an internal pull-down resistor and may be left unconnected in the host system or may be tied to V _{SS} . Do not use these connections for PCB signal routing channels. Do not connect any host system signal to these connections.
RFU	No Connect	Reserved for Future Use. No device internal signal is currently connected to the package connector but there is potential future use for the connector for a signal. It is recommended to not use RFU connectors for PCB routing channels so that the PCB may take advantage of future enhanced features in compatible footprint devices.

2 Block diagrams

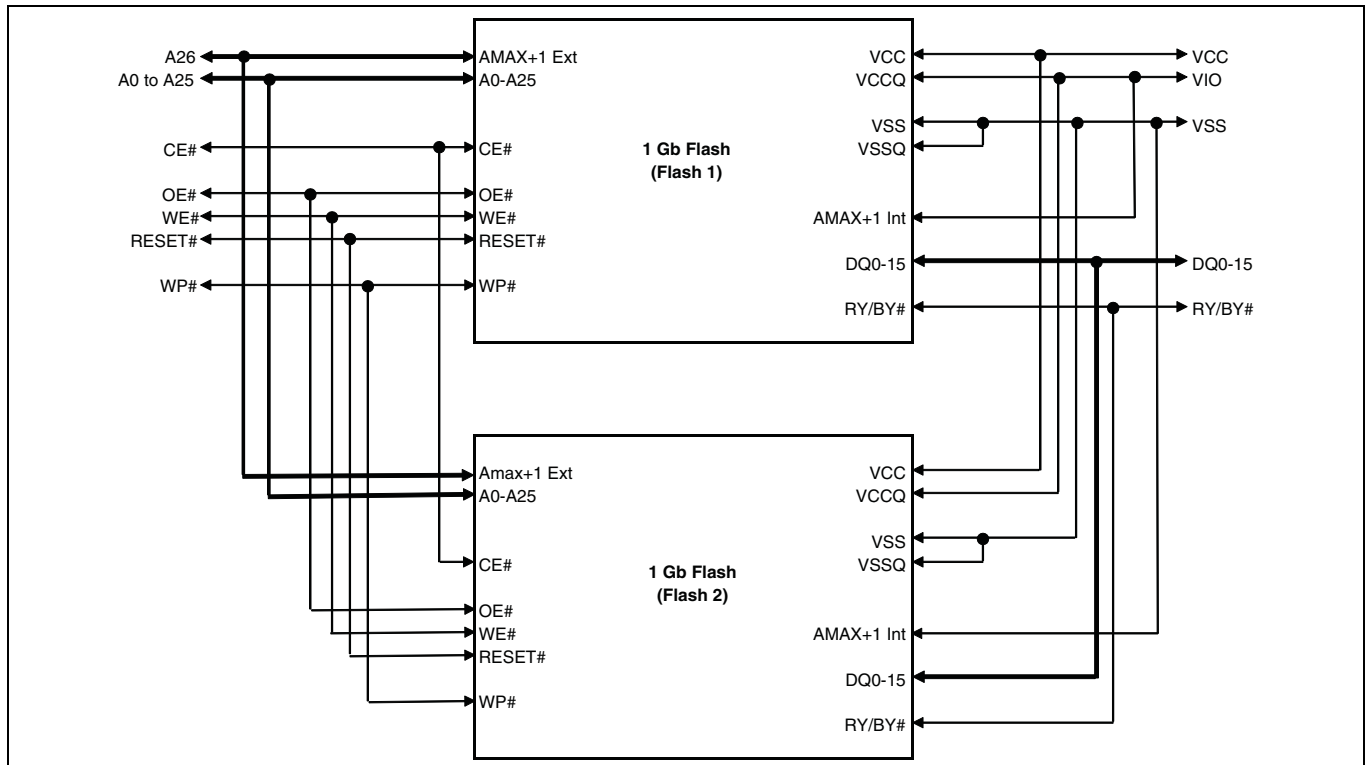

Figure 1 2 x GL01GS (Highest and lowest address sectors protected) block diagram

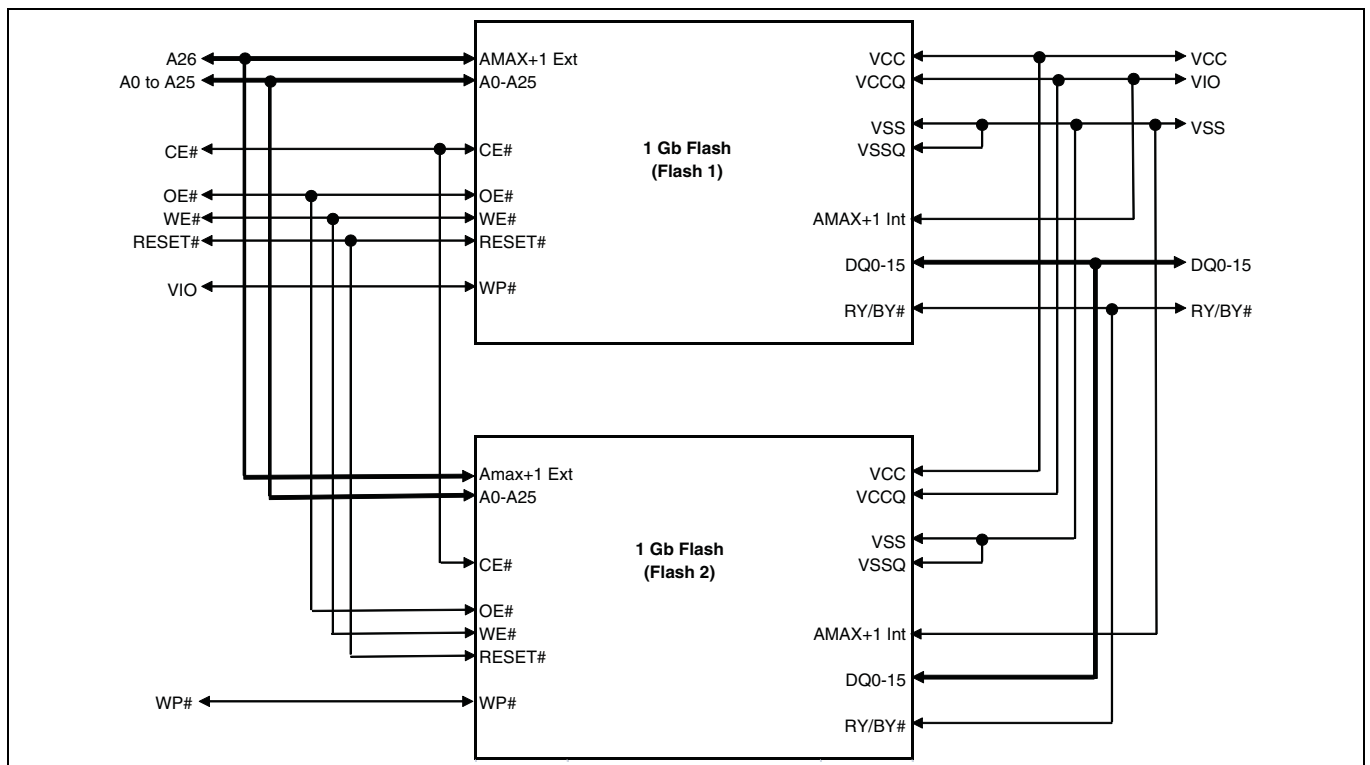

Figure 2 2 x GL01GS (Lowest address sector protected) block diagram

2 Gbit (256 MB) GL-S MIRRORBIT™ Flash Parallel, 3.0 V



Block diagrams

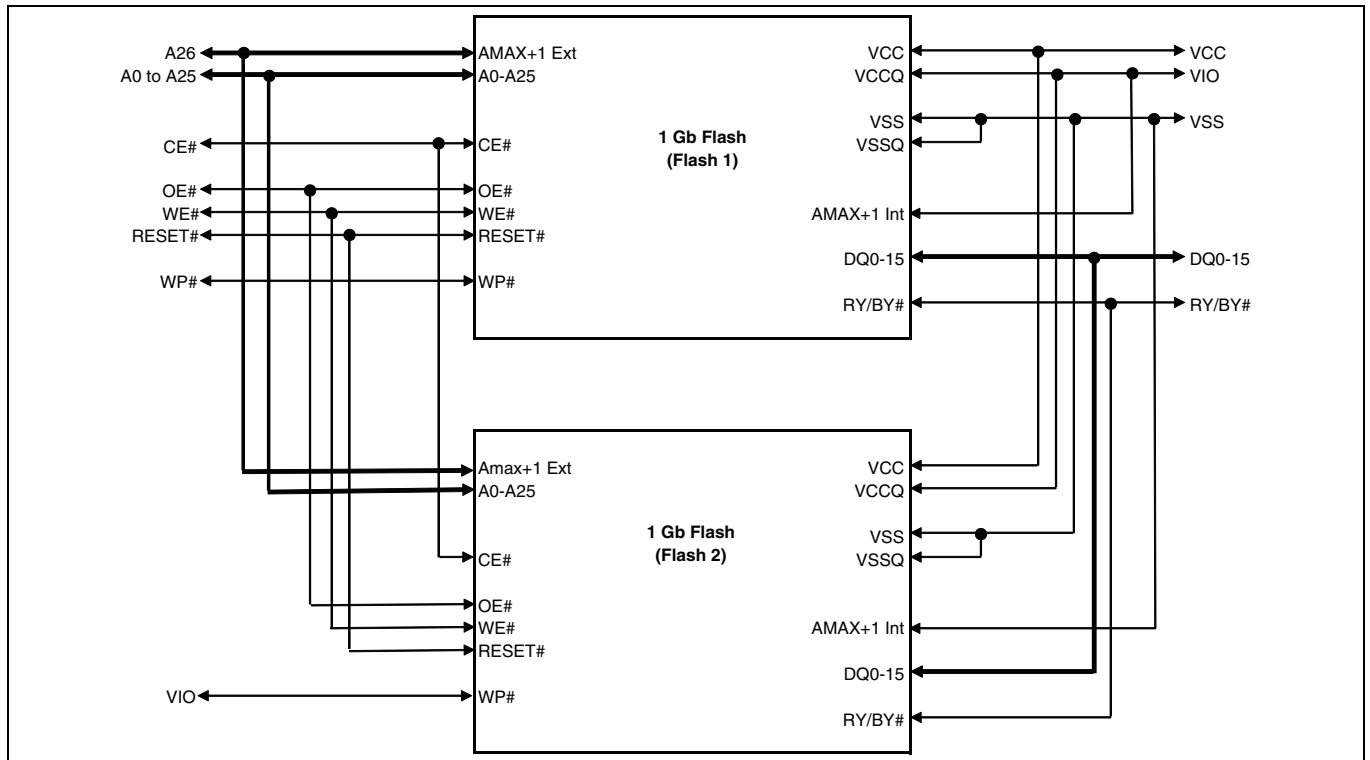

Figure 3 2 x GL01GS (Highest address sector protected) block diagram

3 Connection diagrams

3.1 Special handling instructions for BGA package

Special handling is required for flash memory products in BGA packages.

Flash memory devices in BGA packages may be damaged if exposed to ultrasonic cleaning methods. The package and/or data integrity may be compromised if the package body is exposed to temperatures above 150°C for prolonged periods of time.

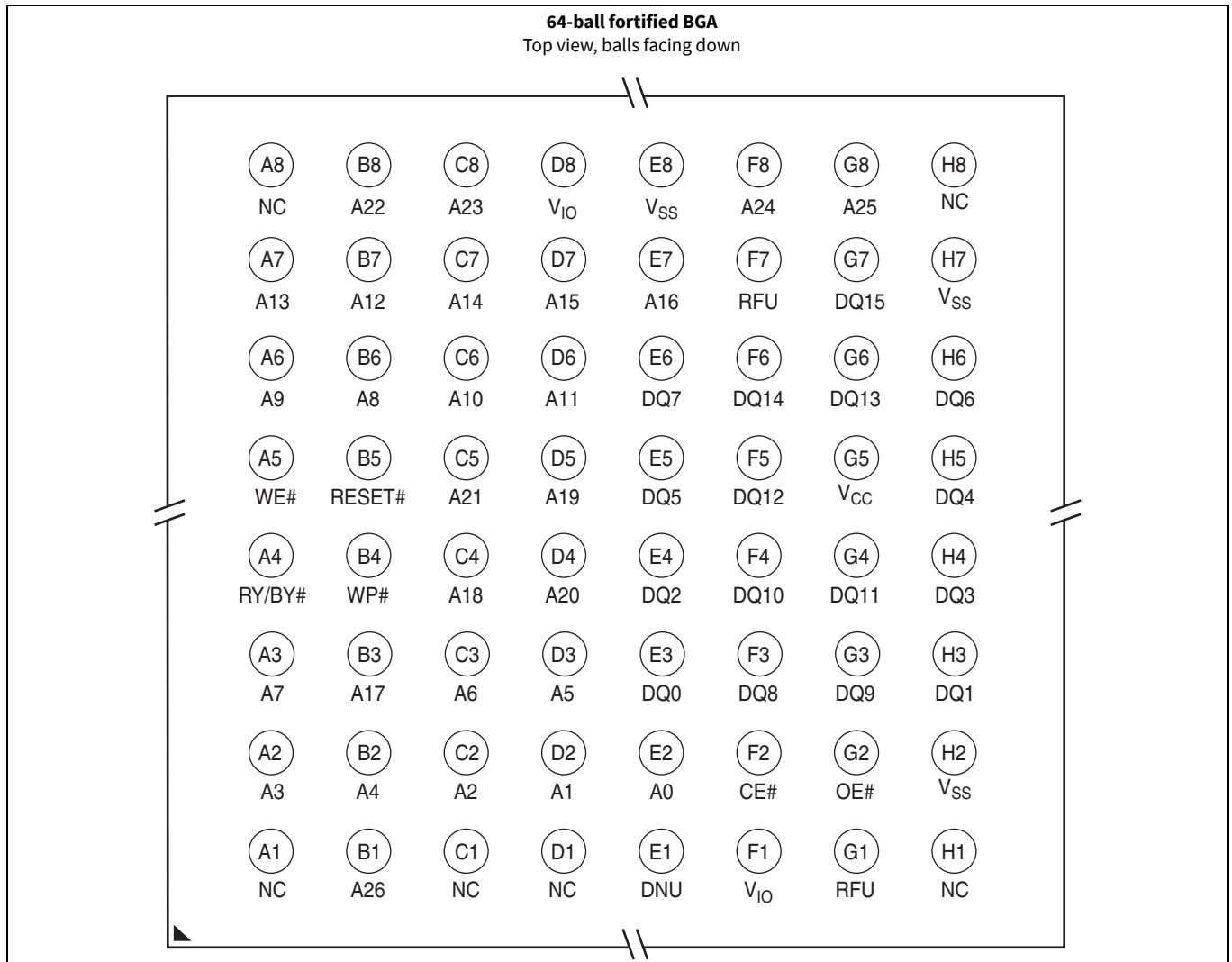

Figure 4 64-ball fortified ball grid array

Notes

- Ball E1, Do Not Use (DNU), a device internal signal is connected to the package connector. The connector may be used by Infineon for test or other purposes and is not intended for connection to any host system signal. Do not use these connections for PCB Signal routing channels. Though not recommended, the ball can be connected to V_{CC} or V_{SS} through a series resistor.
- Balls F7 and G1, Reserved for Future Use (RFU).
- Balls A1, A8, C1, D1, H1, and H8, No Connect (NC).

4 Memory map

The S70GL02GS consist of uniform 64 Kword (128-KB) sectors organized as shown in [Table 2](#).

Table 2 S70GL02GS sector and memory address map

Uniform sector size	Sector count	Sector range	Address range (16-bit)	Notes
64 Kword/128 KB	2048	SA00	0000000h-000FFFFh	Sector starting address
		:	:	
		SA2047	7FF0000H-7FFFFFFFh	Sector ending address

Note

6. This table has been condensed to show sector-related information for an entire device on a single page. Sectors and their address ranges that are not explicitly listed (such as SA001–SA2046) have sector starting and ending addresses that form the same pattern as all other sectors of that size. For example, all 128 KB sectors have the pattern xxx0000h–xxxFFFFh.

5 Second die access

The S70GL02GS device is a dual die stack comprising two S29GL01GS dies connected in parallel, but with only one chip select (CS#) signal. This means that each die receives commands in parallel. The low-address die accepts commands with A26 = 0, while the high-address die accepts commands with A26 = 1. So, it is necessary to set the address bit A26 to '1' while sending commands to access the second die of S70GL02GS. You can manage this by adding the base address for each die to each address argument for each command; the base address for first die is 0x0 and for the second die is 0x4000000. The following table provides an example.

Table 3 Second die access example

	Command sequence to erase first sector in die 1	Command sequence to erase first sector in die 2
1st unlock cycle	Address 0x555 / Data 0xAA	Address 0x4000555 / Data 0xAA
2nd unlock cycle	Address 0x2AA / Data 0x55	Address 0x40002AA / Data 0x55
1st command cycle	Address 0x555 / Data 0x80	Address 0x4000555 / Data 0x80
2nd command cycle	Address 0x555 / Data 0xAA	Address 0x4000555 / Data 0xAA
3rd command cycle	Address 0x2AA / Data 0x55	Address 0x40002AA / Data 0x55
Sector Address / Sector Erase command	Address 0x0000000 / Data 0x30	Address 0x4000000 / Data 0x30

No special address manipulation is required for reading the main flash array. While reading you cannot tell that there are two flash die - only that there is a continuous address space that spans both flash chips.

The special address manipulation is required for writing commands and receiving command response. Many commands have “unlock cycles” consisting of the 555h/AAh and 2AAh/55h address/data pattern. For these cycles A26 must be set correctly, so the unlock cycles are accepted by the intended flash die. Some commands also have address arguments that must be directed to the correct die via A26. These arguments are: Read Address (RA), Program Address (PA), Sector Address (SA), Write Buffer Location (WBL), PassWord Address (PWA), Don't Care (XXX - for single die only)

Autoselect

6 Autoselect

Table 4 provides the device identification codes for the S70GL02GS. For more information on the autoselect function, refer to the S29GL-S datasheet.

Table 4 Autoselect addresses in system

Description	Address	Read data (word/byte mode)
Manufacturer ID	(Base) + 00h	0001h
Device ID, Word 1	(Base) + 01h	227Eh
Device ID, Word 2	(Base) + 0Eh	2248h
Device ID, Word 3	(Base) + 0Fh	2201h
Secure Device Verify	(Base) + 03h	For S70GL02GS highest address sector protect: XX3Fh = Not factory locked XXBFh = Factory locked For S70GL02GS lowest address sector protect: XX2Fh = Not factory locked XXAFh = Factory locked
Sector Protect Verify	(SA) + 02h	xx01h/01h = Locked, xx00h/00h = Unlocked

7 Electrical specifications

7.1 Thermal resistance

Table 5 Thermal resistance

Parameter	Description	Test condition	LSH064	Unit
Theta JA	Thermal resistance (Junction to ambient)	Test conditions follow standard test methods and procedures for measuring thermal impedance in accordance with EIA/JESD51, with Still Air (0 m/s).	29.2	°C/W
Theta JB	Thermal resistance (Junction to board)		11.3	°C/W
Theta JC	Thermal resistance (Junction to case)		8.4	°C/W

8 DC characteristics

Table 6 DC characteristics

Parameter	Description	Test conditions	Min	Typ ^[8]	Max	Unit
I_{LI}	Input load current	$V_{IN} = V_{SS}$ to V_{CC} , $V_{CC} = V_{CC}$ max	-	+0.04	±2.0	μA
I_{LO}	Output leakage current	$V_{OUT} = V_{SS}$ to V_{CC} , $V_{CC} = V_{CC}$ max	-	+0.04	±2.0	μA
I_{CC4}	V_{CC} standby current	CE#, RESET#, OE# = V_{IH} , $V_{IH} = V_{IO}$, $V_{IL} = V_{SS}$, $V_{CC} = V_{CC}$ max	-	140	200	μA
I_{CC5}	V_{CC} reset current ^[8, 9]	CE# = V_{IH} , RESET# = V_{IL} , $V_{CC} = V_{CC}$ max	-	20	40	mA
I_{CC6}	Automatic Sleep mode ^[10]	$V_{IH} = V_{IO}$, $V_{IL} = V_{SS}$, $V_{CC} = V_{CC}$ max, $t_{ACC} + 30$ ns	-	6	12	mA
		$V_{IH} = V_{IO}$, $V_{IL} = V_{SS}$, $V_{CC} = V_{CC}$ max, t_{ASSB}	-	200	300	μA
I_{CC7}	V_{CC} current during power-up ^[8, 13]	RESET# = V_{IO} , CE# = V_{IO} , OE# = V_{IO} , $V_{CC} = V_{CC}$ max	-	106	160	mA

Notes

7. I_{CC} active while Embedded Algorithm is in progress.
8. Not 100% tested.
9. If an embedded operation is in progress at the start of reset, the current consumption will remain at the embedded operation specification until the embedded operation is stopped by the reset. If no embedded operation is in progress when reset is started, or following the stopping of an embedded operation, I_{CC7} will be drawn during the remainder of t_{RPH} . After the end of t_{RPH} the device will go to standby mode until the next read or write.
10. Automatic sleep mode enables the lower power mode when addresses remain stable for a designated time.
11. $V_{IO} = 1.65$ V to V_{CC} or 2.7 V to V_{CC} depending on the model.
12. $V_{CC} = 3$ V and $V_{IO} = 3$ V or 1.8 V. When V_{IO} is at 1.8 V, I/O pins cannot operate at >1.8 V.
13. During power-up there are spikes of current demand, the system needs to be able to supply this current to insure the part initializes correctly.
14. The recommended pull-up resistor for RY/BY# output is 5 kΩ to 10 kΩ.
15. For all other DC current values, refer to the [S29GL-128S_01GS_00](#) datasheet.

BGA package capacitance

9 BGA package capacitance

Table 7 BGA package capacitance

Parameter	Description	Typ	Max	Unit
C _{IN}	Input capacitance	15	16	pF
C _{OUT}	Output capacitance	10	11	pF
A26	Highest order address	6	7	pF
CE#	Separated control pin	12	13	pF
OE#	Separated control pin	7	8	pF
WE#	Separated control pin	11	12	pF
WP#	Separated control pin	11	12	pF
RESET#	Separated control pin	8	9	pF
RY/BY#	Separated control pin	5	6	pF

Notes

- 16. Sampled, not 100% tested.
- 17. Test conditions TA = 25°C, f = 1.0 MHz.

10 Device ID and common flash interface (ID-CFI) ASO map

The device ID portion of the ASO (word locations 0h to 0Fh) provides manufacturer ID, device ID, sector protection state, and basic feature set information for the device.

ID-CFI location 02h displays sector protection status for the sector selected by the sector address (SA) used in the ID-CFI enter command. To read the protection status of more than one sector it is necessary to exit the ID ASO and enter the ID ASO using the new SA. The access time to read location 02h is always t_{ACC} and a read of this location requires CE# to go HIGH before the read and return LOW to initiate the read (asynchronous read access). Page mode read between location 02h and other ID locations is not supported. Page mode read between ID locations other than 02h is supported.

Table 8 ID (Autoselect) address map

Description	Address	Read data
Manufacture ID	(SA) + 0000h	0001h
Device ID	(SA) + 0001h	227Eh
Protection verification	(SA) + 0002h	Sector protection state (1 = Sector protected, 0 = Sector unprotected). This protection state is shown only for the SA selected when entering ID-CFI ASO. Reading other SA provides undefined data. To read a different SA protection state ASO exit command must be used and then enter ID-CFI ASO again with the new SA.
Indicator bits	(SA) + 0003h	For S70GL02GS highest address sector protect: XX3Fh = Not factory locked XXBFh = Factory locked For S70GL02GS lowest address sector protect: XX2Fh = Not factory locked XXAFh = Factory locked DQ15–DQ08 = 1 (Reserved) DQ7 - Factory locked secure silicon region 1 = Locked 0 = Not locked DQ6 - Customer locked secure silicon region 1 = Locked 0 = Not locked DQ5 = 1 (Reserved) DQ4 - WP# Protects 0 = lowest address Sector 1 = highest address Sector DQ3–DQ0 = 1 (Reserved)
RFU	(SA) + 0004h	Reserved
	(SA) + 0005h	Reserved
	(SA) + 0006h	Reserved
	(SA) + 0007h	Reserved
	(SA) + 0008h	Reserved
	(SA) + 0009h	Reserved
	(SA) + 000Ah	Reserved
	(SA) + 000Bh	Reserved

2 Gbit (256 MB) GL-S MIRRORBIT™ Flash
Parallel, 3.0 V



Device ID and common flash interface (ID-CFI) ASO map

Table 8 ID (Autoselect) address map (Continued)

Description	Address	Read data
Lower software bits	(SA) + 000Ch	Bit 0 - Status Register support 1 = Status Register supported 0 = Status Register not supported Bit 1 - DQ polling Support 1 = DQ bits polling supported 0 = DQ bits polling not supported Bit 3-2 - Command set support 11 = reserved 10 = reserved 01 = Reduced Command set 00 = Classic Command set Bits 4-15 - Reserved = 0
Upper software bits	(SA) + 000Dh	Reserved
Device ID	(SA) + 000Eh	2248h = 2 Gb
Device ID	(SA) + 000Fh	2201h

2 Gbit (256 MB) GL-S MIRRORBIT™ Flash Parallel, 3.0 V



Device ID and common flash interface (ID-CFI) ASO map

Table 9 CFI query identification string

Word address	Data	Description
(SA) + 0010h (SA) + 0011h (SA) + 0012h	0051h 0052h 0059h	Query Unique ASCII string "QRY"
(SA) + 0013h (SA) + 0014h	0002h 0000h	Primary OEM Command set
(SA) + 0015h (SA) + 0016h	0040h 0000h	Address for primary extended table
(SA) + 0017h (SA) + 0018h	0000h 0000h	Alternate OEM command set (00h = none exists)
(SA) + 0019h (SA) + 001Ah	0000h 0000h	Address for alternate OEM extended table (00h = none exists)

Table 10 CFI system interface string

Word address	Data	Description
(SA) + 001Bh	0027h	V _{CC} Min. (erase/program) (D7–D4: volts, D3–D0: 100 mV)
(SA) + 001Ch	0036h	V _{CC} Max. (erase/program) (D7–D4: volts, D3–D0: 100 mV)
(SA) + 001Dh	0000h	V _{PP} Min. voltage (00h = no V _{PP} pin present)
(SA) + 001Eh	0000h	V _{PP} Max. voltage (00h = no V _{PP} pin present)
(SA) + 001Fh	0008h	Typical timeout per single word write 2 ^N μs
(SA) + 0020h	0009h	Typical timeout for max multi-byte program, 2 ^N μs (00h = not supported)
(SA) + 0021h	0008h	Typical timeout per individual block erase 2 ^N ms
(SA) + 0022h	0013h (2 Gb)	Typical timeout for full chip erase 2 ^N ms (00h = not supported)
(SA) + 0023h	0001h	Max. timeout for single word write 2 ^N times typical
(SA) + 0024h	0002h	Max. timeout for buffer write 2 ^N times typical
(SA) + 0025h	0003h	Max. timeout per individual block erase 2 ^N times typical
(SA) + 0026h	0003h	Max. timeout for full chip erase 2 ^N times typical (00h = not supported)

2 Gbit (256 MB) GL-S MIRRORBIT™ Flash
Parallel, 3.0 V



Device ID and common flash interface (ID-CFI) ASO map

Table 11 CFI device geometry definition

Word address	Data	Description
(SA) + 0027h	001Ch (2 Gb)	Device Size = 2 ^N byte
(SA) + 0028h	0001h	Flash Device Interface Description 0 = x8-only, 1 = x16-only, 2 = x8/x16 capable
(SA) + 0029h	0000h	
(SA) + 002Ah	0009h	Max. number of byte in multi-byte write = 2 ^N (00 = not supported)
(SA) + 002Bh	0000h	
(SA) + 002Ch	0001h	Number of erase block regions within device 1 = Uniform device, 2 = Boot device
(SA) + 002Dh	00XXh	Erase block region 1 information (refer to JEDEC JESD68-01 or JEP137 specifications) 00FFh, 0007h, 0000h, 0002h = 2 Gb
(SA) + 002Eh	000Xh	
(SA) + 002Fh	0000h	
(SA) + 0030h	000Xh	
(SA) + 0031h	0000h	Erase block region 2 information (refer to CFI publication 100)
(SA) + 0032h	0000h	
(SA) + 0033h	0000h	
(SA) + 0034h	0000h	
(SA) + 0035h	0000h	Erase block region 3 information (refer to CFI publication 100)
(SA) + 0036h	0000h	
(SA) + 0037h	0000h	
(SA) + 0038h	0000h	
(SA) + 0039h	0000h	Erase block region 4 information (refer to CFI publication 100)
(SA) + 003Ah	0000h	
(SA) + 003Bh	0000h	
(SA) + 003Ch	0000h	

2 Gbit (256 MB) GL-S MIRRORBIT™ Flash Parallel, 3.0 V



Device ID and common flash interface (ID-CFI) ASO map

Table 12 CFI primary vendor-specific extended query

Word address	Data	Description
(SA) + 0040h	0050h	Query-unique ASCII string "PRI"
(SA) + 0041h	0052h	
(SA) + 0042h	0049h	
(SA) + 0043h	0031h	Major version number, ASCII
(SA) + 0044h	0035h	Minor version number, ASCII
(SA) + 0045h	001Ch	Address sensitive unlock (Bits 1–0) 00b = Required 01b = Not required Process technology (Bits 5–2) 0000b = 0.23 μm floating gate 0001b = 0.17 μm floating gate 0010b = 0.23 μm MIRRORBIT™ 0011b = 0.13 μm floating gate 0100b = 0.11 μm MIRRORBIT™ 0101b = 0.09 μm floating gate 0110b = 0.09 μm MIRRORBIT™ 0111b = 0.065 μm MIRRORBIT™ Eclipse 1000b = 0.065 μm MIRRORBIT™ 1001b = 0.045 μm MIRRORBIT™
(SA) + 0046h	0002h	Erase Suspend 0 = Not supported 1 = Read only 2 = Read and write
(SA) + 0047h	0001h	Sector protect 00 = Not supported X = Number of sectors in smallest group
(SA) + 0048h	0000h	Temporary sector unprotect 00 = Not supported 01 = Supported
(SA) + 0049h	0008h	Sector protect/unprotect scheme 04 = High voltage method 05 = Software command locking method 08 = Advanced sector protection method
(SA) + 004Ah	0000h	Simultaneous operation 00 = Not supported X = Number of banks
(SA) + 004Bh	0000h	Burst mode type 00 = Not supported 01 = Supported
(SA) + 004Ch	0003h	Page mode type 00 = Not supported 01 = 4 word page 02 = 8 word page 03 = 16 word page
(SA) + 004Dh	0000h	ACC (Acceleration) supply minimum 00 = Not supported D7–D4: Volt D3–D0: 100 mV

2 Gbit (256 MB) GL-S MIRRORBIT™ Flash Parallel, 3.0 V



Device ID and common flash interface (ID-CFI) ASO map

Table 12 CFI primary vendor-specific extended query (Continued)

Word address	Data	Description
(SA) + 004Eh	0000h	ACC (Acceleration) supply maximum 00 = Not supported D7-D4: Volt D3-D0: 100 mV
(SA) + 004Fh	0004h (Bottom) 0005h (Top)	WP# Protection 00h = Flash device without WP Protect (No boot) 01h = Eight 8 KB sectors at top and bottom with WP (Dual boot) 02h = Bottom boot device with WP protect (Bottom boot) 03h = Top boot device with WP protect (Top boot) 04h = Uniform, bottom WP protect (Uniform bottom boot) 05h = Uniform, top WP protect (Uniform top boot) 06h = WP Protect for all sectors 07h = Uniform, top or bottom WP protect
(SA) + 0050h	0001h	Program Suspend 00 = Not supported 01 = Supported
(SA) + 0051h	0000h	Unlock Bypass 00 = Not supported 01 = Supported
(SA) + 0052h	0009h	Secured silicon sector (Customer OTP area) size 2^N (bytes)
(SA) + 0053h	008Fh	Software features bit 0: Status Register polling (1 = Supported, 0 = Not supported) bit 1: DQ polling (1 = Supported, 0 = Not supported) bit 2: New Program Suspend/Resume commands (1 = Supported, 0 = Not supported) bit 3: Word programming (1 = Supported, 0 = Not supported) bit 4: Bit-field programming (1 = Supported, 0 = Not supported) bit 5: Autodetect programming (1 = Supported, 0 = Not supported) bit 6: RFU bit 7: Multiple writes per line (1 = Supported, 0 = Not supported)
(SA) + 0054h	0005h	Page Size = 2^N bytes
(SA) + 0055h	0006h	Erase Suspend timeout maximum $< 2^N$ (μ s)
(SA) + 0056h	0006h	Program Suspend timeout maximum $< 2^N$ (μ s)
(SA) + 0078h	0006h	Embedded hardware reset timeout maximum $< 2^N$ (μ s) Reset with reset pin
(SA) + 0079h	0009h	Non-embedded hardware reset timeout maximum $< 2^N$ (μ s) Power-on reset

11 Package diagram

11.1 LSH064 – 64-ball fortified ball grid array, 13 x 11 mm

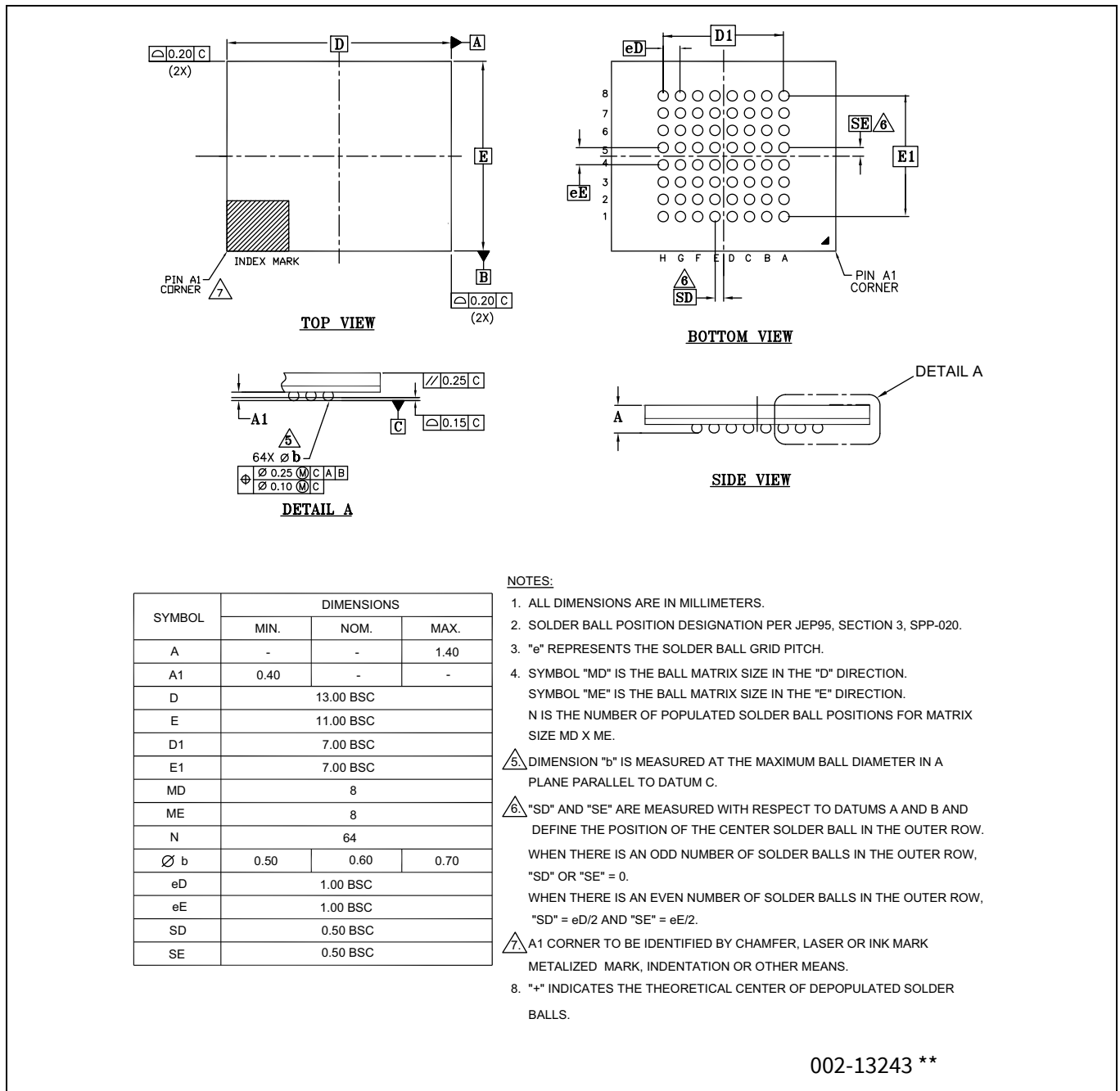

Figure 5 64-ball FBGA (13.0 x 11.0 x 1.4 mm) package outline (PG-LFBGA-64), 002-13243

12 Ordering information

12.1 Recommended combinations

Recommended combinations table below list various configurations planned to be available in volume. **Table 13** will be updated as new combinations are released. Contact your local Infineon sales representative to confirm availability of specific configuration not listed or to check on newly released combinations.

Table 13 S29GL-S valid combinations

Base OPN	Speed (ns)	Package and temperature	Model number	Packing type	Ordering part number (yy = Model number, x = Packing type)
S70GL02GS	110	FHI, FHV ^[18]	01, 02	0, 3 ^[19]	S70GL02GS11FHI01x S70GL02GS11FHI02x S70GL02GS11FHV01x S70GL02GS11FHV02x
	120		V1, V2		S70GL02GS12FHIV1x S70GL02GS12FHIV2x S70GL02GS12FHV1x S70GL02GS12FHV2x

Table 14 lists configurations that are automotive grade / AEC-Q100 qualified and are planned to be available in volume. The table will be updated as new combinations are released. Consult your local sales representative to confirm availability of specific combinations and to check on newly released combinations.

Production part approval process (PPAP) support is only provided for AEC-Q100 grade products.

Products to be used in end-use applications that require ISO/TS-16949 compliance must be AEC-Q100 grade products in combination with PPAP. Non-AEC-Q100 grade products are not manufactured or documented in full compliance with ISO/TS-16949 requirements.

AEC-Q100 grade products are also offered without PPAP support for end-use applications that do not require ISO/TS-16949 compliance.

Table 14 Valid combinations – automotive grade / AEC-Q100

Base OPN	Speed (ns)	Package and temperature	Model number	Packing type	Ordering part number (yy = Model Number, x = Packing Type)
S70GL02GS	110	FHA, FHB ^[18]	01, 02	0, 3 ^[19]	S70GL02GS11FHA01x S70GL02GS11FHA02x S70GL02GS11FHB01x S70GL02GS11FHB02x
	120		V1, V2		S70GL02GS12FHAV1x S70GL02GS12FHAV2x S70GL02GS12FHBV1x S70GL02GS12FHBV2x

Notes

18.BGA package marking omits leading “S70” and packing type designator from ordering part number.

19.Packing Type “0” is standard option.

2 Gbit (256 MB) GL-S MIRRORBIT™ Flash

Parallel, 3.0 V



Ordering information

The ordering part number is formed by a valid combination of the following:

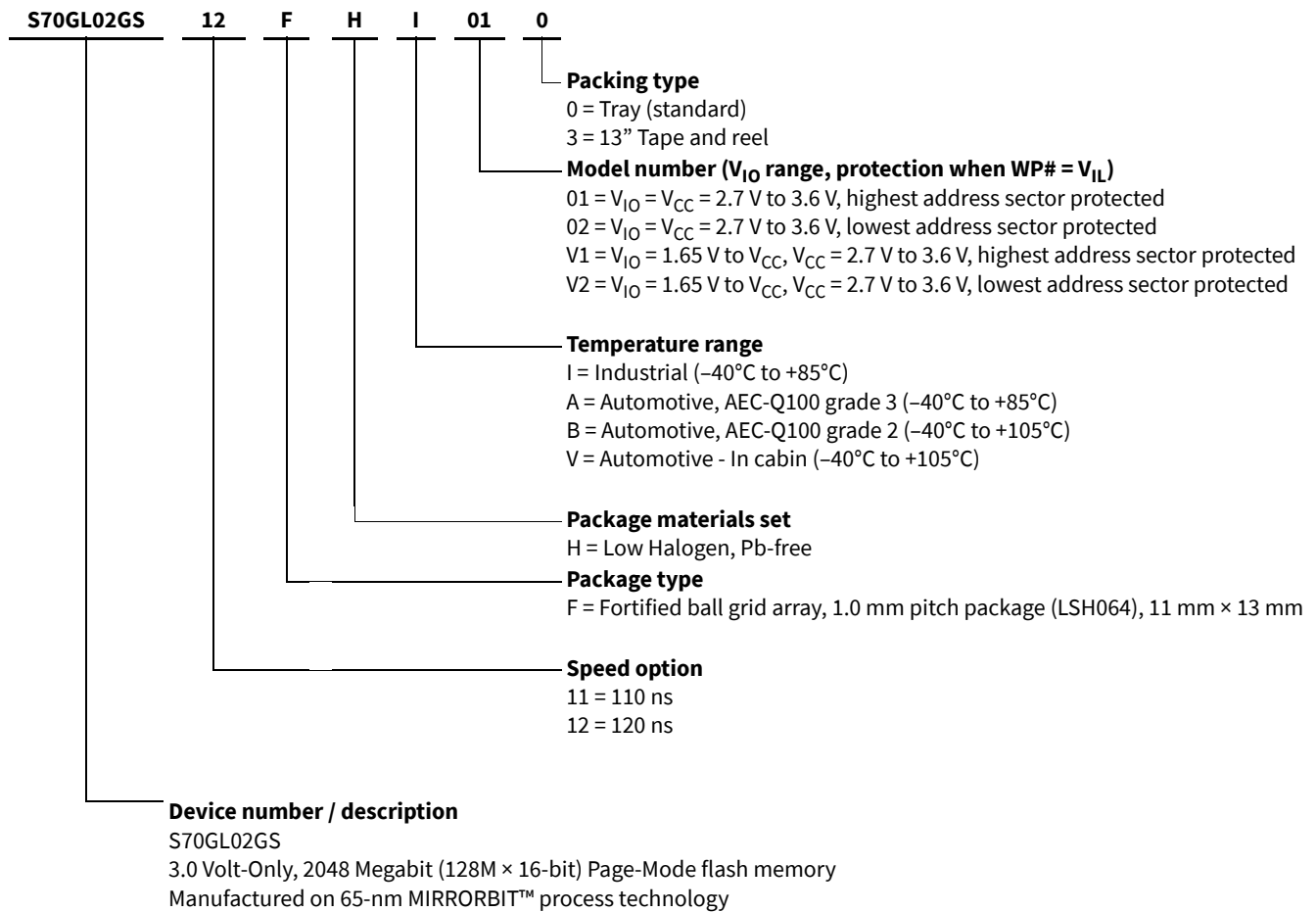

Revision history

Document revision	Date	Description of changes
**	2011-05-19	Spansion Publication Number: S70GL-S_00 Initial release.
*A	2011-07-08	Performance Characteristics: Updated Typical Program and Erase Rates Ordering Information: Updated model number description of V1 and V2 DC Characteristics: Modified Note 3
*B	2011-09-23	Distinctive Characteristics: Cosmetic changes Ordering Information: Updated CFI Device Geometry Definition: Data at (SA) + 002Eh modified
*C	2011-12-15	Global: Data sheet status changed from Preliminary to Full Production Performance Characteristics: Updated Sector Erase time Figure: 64-ball Fortified Ball Grid Array: Added notes BGA Package Capacitance: Updated
*D	2014-06-27	Global: Added –40°C to +105°C temperature range
*E	2015-08-13	Updated to Cypress template.
*F	2016-03-04	General Description: Updated Cypress Document Number as “001-98285” in the table. Distinctive Characteristics: Updated link to S29GL01GS datasheet. Updated to new template.
*G	2016-07-08	Updated Document Title to read as “S70GL02GS 2 Gbit (256 MB) GL-S MIRRORBIT™ Flash”. Updated to new template.
*H	2017-05-31	Updated Cypress Logo and Copyright.
*I	2017-06-15	Updated Ordering information: Updated description. Added Table 14 . Updated details under “Temperature range” in valid combination.
*J	2017-08-09	Updated Ordering information: Updated details under “Device number/description” in valid combination. Added Second die access .
*K	2022-09-09	Updated document Title to read as “S70GL02GS, 2 Gbit (256 MB) GL-S MIRRORBIT™ Flash Parallel, 3.0 V”. Updated Distinctive characteristics: Updated hyperlinks. Updated Electrical specifications: Added Thermal resistance . Updated Package diagram: Updated LSH064 – 64-ball fortified ball grid array, 13 x 11 mm: Replaced existing spec with 002-13243 **. Migrated to Infineon template.
*L	2023-08-11	Updated the term “GL-T” to “GL-S” in the document (in the document title and revision history table). Updated the URL reference for the S29GL01GS datasheet. Added the “ PG-LFBGA-64 ” package number to the Figure 5 caption.

Trademarks

All referenced product or service names and trademarks are the property of their respective owners.

Edition 2023-08-11

Published by

**Infineon Technologies AG
81726 Munich, Germany**

**© 2023 Infineon Technologies AG.
All Rights Reserved.**

Do you have a question about this document?

Email:

erratum@infineon.com

Document reference

001-98296 Rev. *L

IMPORTANT NOTICE

The information given in this document shall in no event be regarded as a guarantee of conditions or characteristics ("Beschaffenheitsgarantie").

With respect to any examples, hints or any typical values stated herein and/or any information regarding the application of the product, Infineon Technologies hereby disclaims any and all warranties and liabilities of any kind, including without limitation warranties of non-infringement of intellectual property rights of any third party.

In addition, any information given in this document is subject to customer's compliance with its obligations stated in this document and any applicable legal requirements, norms and standards concerning customer's products and any use of the product of Infineon Technologies in customer's applications.

The data contained in this document is exclusively intended for technically trained staff. It is the responsibility of customer's technical departments to evaluate the suitability of the product for the intended application and the completeness of the product information given in this document with respect to such application.

WARNINGS

Due to technical requirements products may contain dangerous substances. For information on the types in question please contact your nearest Infineon Technologies office.

Except as otherwise explicitly approved by Infineon Technologies in a written document signed by authorized representatives of Infineon Technologies, Infineon Technologies' products may not be used in any applications where a failure of the product or any consequences of the use thereof can reasonably be expected to result in personal injury.

Looking for pricing, stock, or lifecycle information?

Click below to explore more details on WIN SOURCE:

- ⊖ [View S70GL02GS12FHIV20 on WIN SOURCE](#)
- ⊖ [Cypress Semiconductor Corp Information](#)

Optimize Your Supply Chain with WIN SOURCE Solutions

- ✓ Global Sourcing Solution
- ✓ Obsolete Management
- ✓ Cost Control Management
- ✓ Shortage Management
- ✓ Alternative Solution
- ✓ Excess Inventory Management