



THE DATASHEET OF VNQ810P-E



Quad channel high-side driver

Features

Type	$R_{DS(on)}$	I_{OUT}	V_{CC}
VNQ810P-E	160m Ω ⁽¹⁾	3.5A ⁽¹⁾	36V

1. Per each channel.

- ECOPACK[®]: lead free and RoHS compliant
- Automotive Grade: compliance with AEC guidelines
- Very low standby current
- CMOS compatible input
- On-state open-load detection
- Off-state open-load detection
- Thermal shutdown protection and diagnosis
- Undervoltage shutdown
- Overvoltage clamp
- Output stuck to V_{CC} detection
- Load current limitation
- Reverse battery protection
- Electrostatic discharge protection

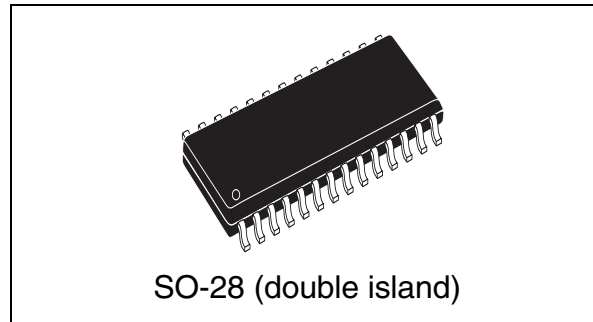

Description

The VNQ810P-E is a quad HSD formed by assembling two VND810P-E chips in the same SO-28 package. The VNQ810P-E is a monolithic device made by using STMicroelectronics VIPower[™] M0-3 technology, intended for driving any kind of load with one side connected to ground. Active V_{CC} pin voltage clamp protects the device against low energy spikes (see ISO7637 transient compatibility table).

Active current limitation combined with thermal shutdown and automatic restart protects the device against overload. The device detects open-load condition both in on and off-state. Output shorted to V_{CC} is detected in the off-state. Device automatically turns off in case of ground pin disconnection.

Table 1. Device summary

Package	Order codes	
	Tube	Tape and reel
SO-28 (double island)	VNQ810P-E	VNQ810PTR-E

Contents

1	Block diagram and pin description	5
2	Electrical specifications	7
2.1	Absolute maximum ratings	7
2.2	Thermal data	7
2.3	Electrical characteristics	8
2.4	Electrical characteristics curves	14
3	Application information	17
3.1	GND protection network against reverse battery	17
3.1.1	Solution 1: a resistor in the ground line (RGND only)	17
3.1.2	Solution 2: a diode (D_{GND}) in the ground line	18
3.2	Load dump protection	18
3.3	MCU I/O protection	18
3.4	Open-load detection in off-state	19
3.5	Maximum demagnetization energy ($V_{CC} = 13.5V$)	20
4	Package and PCB thermal data	21
4.1	SO-28 thermal data	21
5	Package and packing information	24
5.1	ECOPACK [®] packages	24
5.2	SO-28 package information	24
5.3	SO-28 packing information	26
6	Revision history	27

List of tables

Table 1.	Device summary	1
Table 2.	Suggested connections for unused and not connected pins	6
Table 3.	Absolute maximum ratings	7
Table 4.	Thermal data (per island)	7
Table 5.	Power output.	8
Table 7.	V _{CC} - output diode	9
Table 8.	Status pin	9
Table 9.	Switching (V _{CC} = 13V)	9
Table 6.	Protections	9
Table 10.	Open-load detection	10
Table 11.	Logic inputs.	10
Table 12.	Truth table.	11
Table 13.	Electrical transient requirements on V _{CC} pin (part 1/3).	12
Table 14.	Electrical transient requirements on V _{CC} pin (part 2/3).	12
Table 15.	Electrical transient requirements on V _{CC} pin (part 3/3).	12
Table 16.	Thermal calculation according to the PCB heatsink area	21
Table 17.	Thermal parameters	23
Table 18.	SO-28 mechanical data	25
Table 19.	Document revision history	27

List of figures

Figure 1.	Block diagram	5
Figure 2.	Configuration diagram (top view)	6
Figure 3.	Current and voltage conventions	8
Figure 4.	Status timings	10
Figure 5.	Switching time Waveforms	11
Figure 6.	Waveforms	13
Figure 7.	Off-state output current	14
Figure 8.	High level input current	14
Figure 9.	Input clamp voltage	14
Figure 10.	Status leakage current	14
Figure 11.	Status low output voltage	14
Figure 12.	Status clamp voltage	14
Figure 13.	Overshoot shutdown	15
Figure 14.	I_{LIM} vs T_{case}	15
Figure 15.	Turn-on voltage slope	15
Figure 16.	Turn-off voltage slope	15
Figure 17.	On-state resistance vs T_{case}	15
Figure 18.	On-state resistance vs V_{CC}	15
Figure 19.	Input high level	16
Figure 20.	Input low level	16
Figure 21.	Open-load on-state detection threshold	16
Figure 22.	Open-load off-state voltage detection threshold	16
Figure 23.	Input hysteresis voltage	16
Figure 24.	Application schematic	17
Figure 25.	Open-load detection in off-state	19
Figure 26.	SO-28 (double island) maximum turn-off current versus load inductance	20
Figure 27.	SO-28 double island PC board	21
Figure 28.	$R_{thj-amb}$ vs PCB copper area in open box free air condition	22
Figure 29.	SO-28 thermal impedance junction ambient single pulse	22
Figure 30.	Thermal fitting model of a quad channel HSD in SO-28	23
Figure 31.	SO-28 package dimensions	24
Figure 32.	SO-28 tube shipment (no suffix)	26
Figure 33.	SO-28 tape and reel shipment (suffix "TR")	26

1 Block diagram and pin description

Figure 1. Block diagram

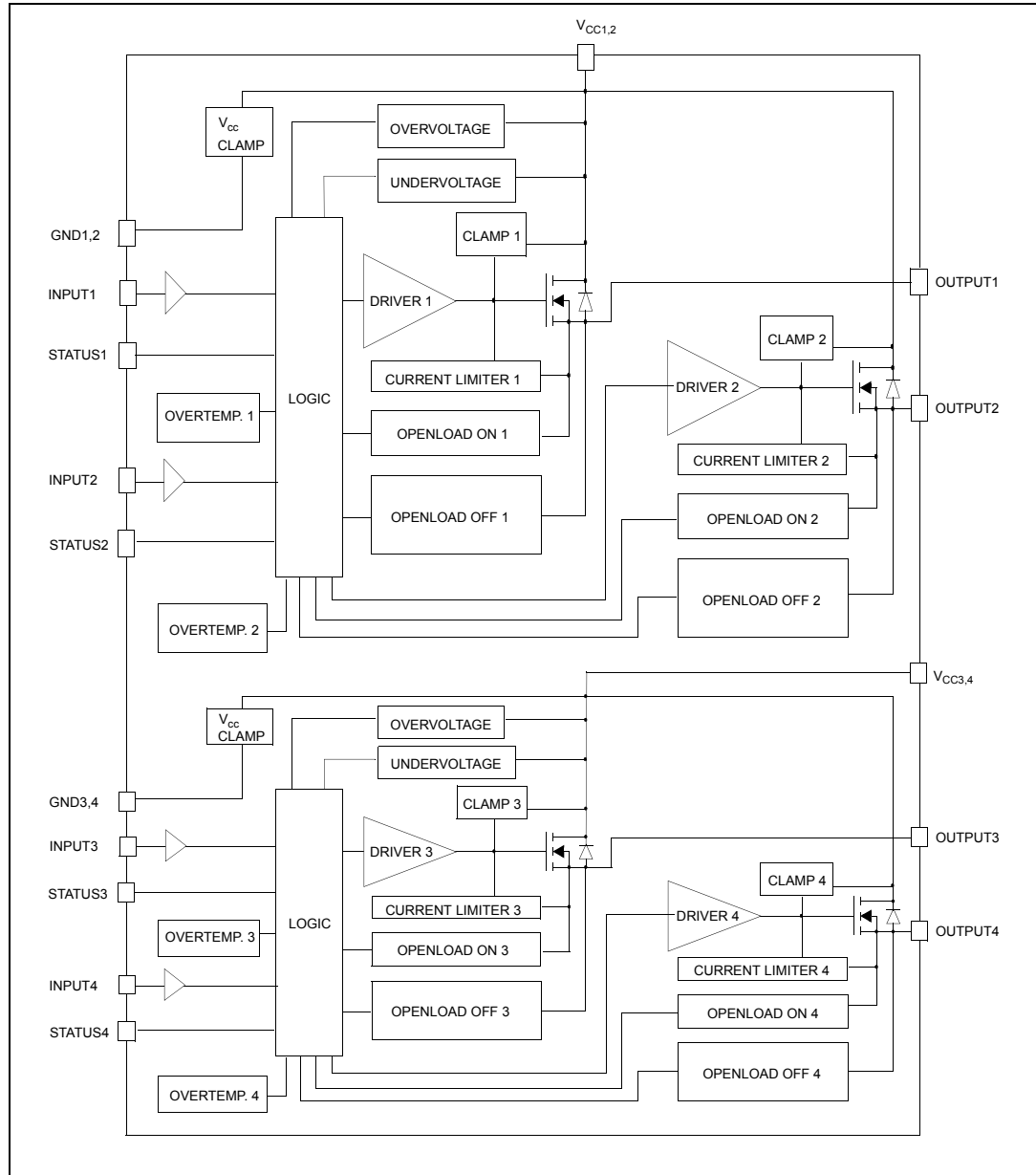

Figure 2. Configuration diagram (top view)

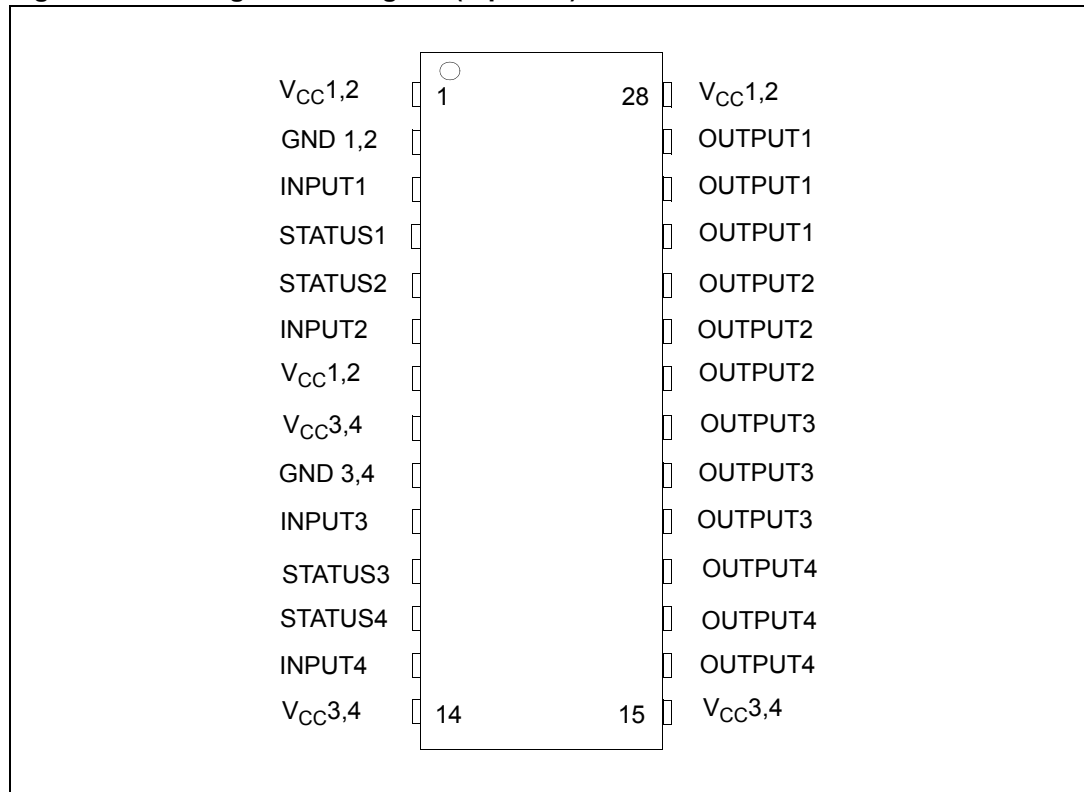

Table 2. Suggested connections for unused and not connected pins

Connection / pin	Status	N.C.	Output	Input
Floating	X	X	X	X
To ground		X		Through 10 KΩ resistor

2 Electrical specifications

2.1 Absolute maximum ratings

Stressing the device above the rating listed in the [Table 5](#) may cause permanent damage to the device. These are stress ratings only and operation of the device at these or any other conditions above those indicated in the operating sections of this specification is not implied. Exposure to absolute maximum rating conditions for extended periods may affect device reliability. Refer also to the STMicroelectronics SURE program and other relevant quality document.

Table 3. Absolute maximum ratings

Symbol	Parameter	Value	Unit
V_{CC}	DC supply voltage	41	V
$-V_{CC}$	Reverse DC supply voltage	-0.3	V
$-I_{GND}$	DC reverse ground pin current	-200	mA
I_{OUT}	DC output current	Internally limited	A
$-I_{OUT}$	Reverse DC output current	-6	A
I_{IN}	DC input current	+/-10	mA
I_{STAT}	DC Status current	+/-10	mA
V_{ESD}	Electrostatic discharge (human body model: R = 1.5 K Ω ; C = 100 pF)		
	- INPUT	4000	V
	- STATUS	4000	V
	- OUTPUT	5000	V
	- V_{CC}	5000	V
E_{MAX}	Maximum switching energy (L = 2.5 mH; R _L = 0 Ω ; V _{bat} = 13.5 V; T _{jstart} = 150 °C; I _L = 9 A)	23	mJ
P_{tot}	Power dissipation (per island) at T _{lead} = 25°C	6.25	W
T_j	Junction operating temperature	Internally limited	°C
T_{stg}	Storage temperature	- 55 to 150	°C

2.2 Thermal data

Table 4. Thermal data (per island)

Symbol	Parameter	Value		Unit
$R_{thj-lead}$	Thermal resistance junction-lead	20		°C/W
$R_{thj-amb}$	Thermal resistance junction-ambient (one chip ON)	60 ⁽¹⁾	44 ⁽²⁾	°C/W
$R_{thj-amb}$	Thermal resistance junction-ambient (two chips ON)	46 ⁽¹⁾	31 ⁽²⁾	°C/W

- When mounted on a standard single-sided FR-4 board with 0.5 cm² of Cu (at least 35 μ m thick) connected to all V_{CC} pins. Horizontal mounting and no artificial air flow.
- When mounted on a standard single-sided FR-4 board with 6 cm² of Cu (at least 35 μ m thick) connected to all V_{CC} pins. Horizontal mounting and no artificial air flow.

2.3 Electrical characteristics

Values specified in this section are for $8\text{ V} < V_{CC} < 36\text{ V}$; $-40\text{ }^\circ\text{C} < T_j < 150\text{ }^\circ\text{C}$, unless otherwise stated.

Figure 3. Current and voltage conventions

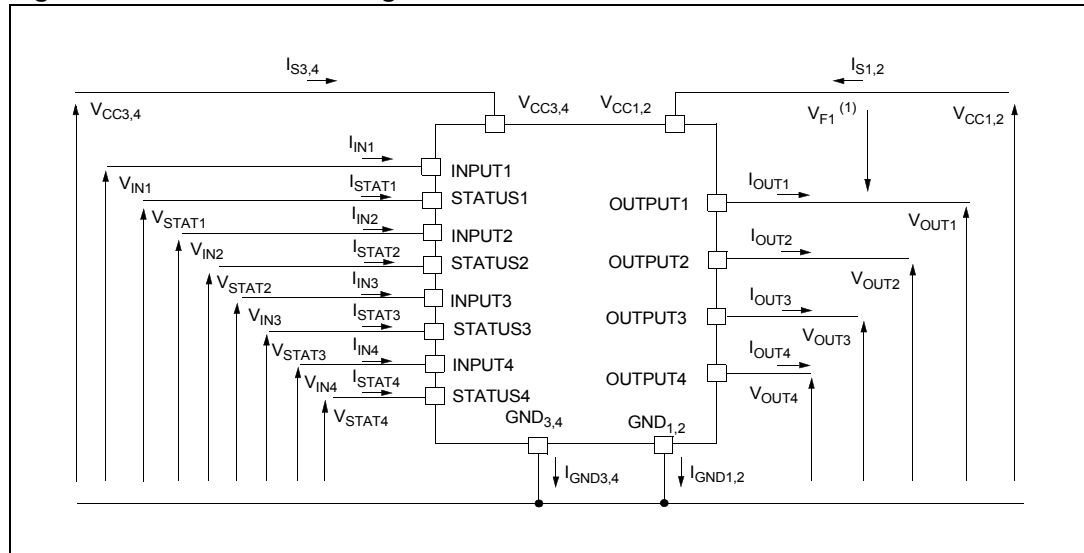

1. $V_{Fn} = V_{CCn} - V_{OUTn}$ during reverse battery condition.

Table 5. Power output

Symbol	Parameter	Test conditions	Min.	Typ.	Max.	Unit
$V_{CC}^{(1)}$	Operating supply voltage		5.5	13	36	V
$V_{USD}^{(1)}$	Undervoltage shutdown		3	4	5.5	V
$V_{OV}^{(1)}$	Overvoltage shutdown		36			V
R_{ON}	On-state resistance	$I_{OUT} = 1\text{ A}$; $T_j = 25\text{ }^\circ\text{C}$ $I_{OUT} = 1\text{ A}$; $V_{CC} > 8\text{ V}$			160 320	mΩ mΩ
I_S	Supply current	Off-state; $V_{CC} = 13\text{ V}$; $V_{IN} = V_{OUT} = 0\text{ V}$		12	40	μA
		Off-state; $V_{CC} = 13\text{ V}$; $V_{IN} = V_{OUT} = 0\text{ V}$; $T_j = 25\text{ }^\circ\text{C}$		12	25	μA
		On-state; $V_{CC} = 13\text{ V}$; $V_{IN} = 5\text{ V}$; $I_{OUT} = 0\text{ A}$		5	7	mA
$I_{L(off1)}$	Off-state output current	$V_{IN} = V_{OUT} = 0\text{ V}$	0		50	μA
$I_{L(off2)}$	Off-state output current	$V_{IN} = 0\text{ V}$; $V_{OUT} = 3.5\text{ V}$	-75		0	μA
$I_{L(off3)}$	Off-state output current	$V_{IN} = V_{OUT} = 0\text{ V}$; $V_{CC} = 13\text{ V}$; $T_j = 125\text{ }^\circ\text{C}$			5	μA
$I_{L(off4)}$	Off-state output current	$V_{IN} = V_{OUT} = 0\text{ V}$; $V_{CC} = 13\text{ V}$; $T_j = 25\text{ }^\circ\text{C}$			3	μA

1. Per island.

Table 6. Protections⁽¹⁾

Symbol	Parameter	Test conditions	Min.	Typ.	Max.	Unit
T_{TSD}	Shutdown temperature		150	175	200	°C
T_R	Reset temperature		135			°C
T_{hyst}	Thermal hysteresis		7	15		°C
t_{SDL}	Status delay in overload conditions	$T_j > T_{TSD}$			20	µs
I_{lim}	Current limitation	$V_{CC} = 13\text{ V}$	3.5	5	7.5	A
		$5.5\text{ V} < V_{CC} < 36\text{ V}$			7.5	A
V_{demag}	Turn-off output clamp voltage	$I_{OUT} = 1\text{ A}; L = 6\text{ mH}$	$V_{CC}-41$	$V_{CC}-48$	$V_{CC}-55$	V

1. To ensure long term reliability under heavy overload or short circuit conditions, protection and related diagnostic signals must be used together with a proper software strategy. If the device is subjected to abnormal conditions, this software must limit the duration and number of activation cycles.

Table 7. V_{CC} - output diode

Symbol	Parameter	Test conditions	Min.	Typ.	Max.	Unit
V_F	Forward on voltage	$-I_{OUT} = 0.5\text{ A}; T_j = 150\text{ °C}$	-	-	0.6	V

Table 8. Status pin

Symbol	Parameter	Test conditions	Min.	Typ.	Max.	Unit
V_{STAT}	Status low output voltage	$I_{STAT} = 1.6\text{ mA}$			0.5	V
I_{LSTAT}	Status leakage current	Normal operation; $V_{STAT} = 5\text{ V}$			10	µA
C_{STAT}	Status pin Input capacitance	Normal operation; $V_{STAT} = 5\text{ V}$			100	pF
V_{SCL}	Status clamp voltage	$I_{STAT} = 1\text{ mA}$	6	6.8	8	V
		$I_{STAT} = -1\text{ mA}$		-0.7		V

Table 9. Switching ($V_{CC} = 13\text{ V}$)

Symbol	Parameter	Test conditions	Min.	Typ.	Max.	Unit
$t_{d(on)}$	Turn-on delay time	$R_L = 13\ \Omega$ from V_{IN} rising edge to $V_{OUT} = 1.3\text{ V}$	-	30	-	µs
$t_{d(off)}$	Turn-off delay time	$R_L = 13\ \Omega$ from V_{IN} falling edge to $V_{OUT} = 11.7\text{ V}$	-	30	-	µs
$dV_{OUT}/dt_{(on)}$	Turn-on voltage slope	$R_L = 13\ \Omega$ from $V_{OUT} = 1.3\text{ V}$ to $V_{OUT} = 10.4\text{ V}$	-	See Figure 10	-	V/µs
$dV_{OUT}/dt_{(off)}$	Turn-off voltage slope	$R_L = 13\ \Omega$ from $V_{OUT} = 11.7\text{ V}$ to $V_{OUT} = 1.3\text{ V}$	-	See Figure 12	-	V/µs

Table 10. Open-load detection

Symbol	Parameter	Test conditions	Min.	Typ.	Max.	Unit
I_{OL}	Open-load on-state detection threshold	$V_{IN} = 5\text{ V}$	20	40	80	mA
$t_{DOL(on)}$	Open-load on-state detection delay	$I_{OUT} = 0\text{ A}$			200	μs
V_{OL}	Open-load off-state voltage detection threshold	$V_{IN} = 0\text{ V}$	1.5	2.5	3.5	V
$t_{DOL(off)}$	Open-load detection delay at turn-off				1000	μs

Table 11. Logic inputs

Symbol	Parameter	Test conditions	Min.	Typ.	Max.	Unit
V_{IL}	Input low level				1.25	V
I_{IL}	Low level input current	$V_{IN} = 1.25\text{ V}$	1			μA
V_{IH}	Input high level		3.25			V
I_{IH}	High level input current	$V_{IN} = 3.25\text{ V}$			10	μA
$V_{I(hyst)}$	Input hysteresis voltage		0.5			V
V_{ICL}	Input clamp voltage	$I_{IN} = 1\text{ mA}$	6	6.8	8	V
		$I_{IN} = -1\text{ mA}$		-0.7		V

Figure 4. Status timings

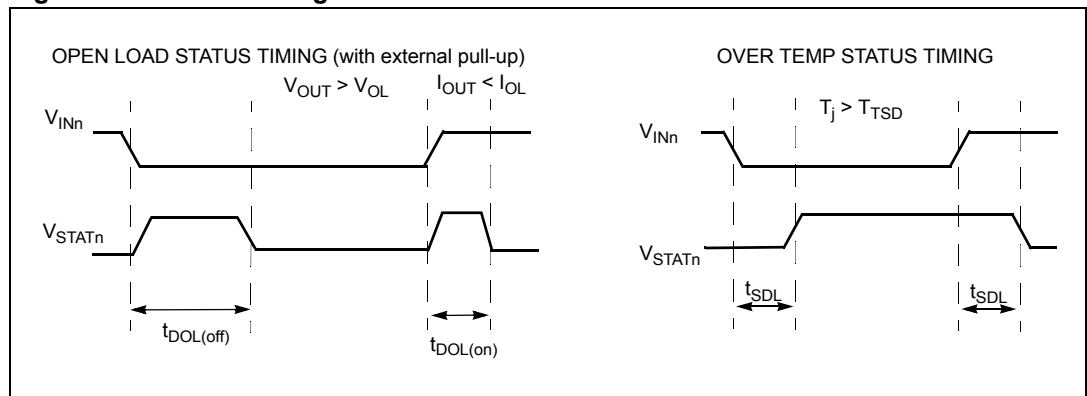

Figure 5. Switching time Waveforms

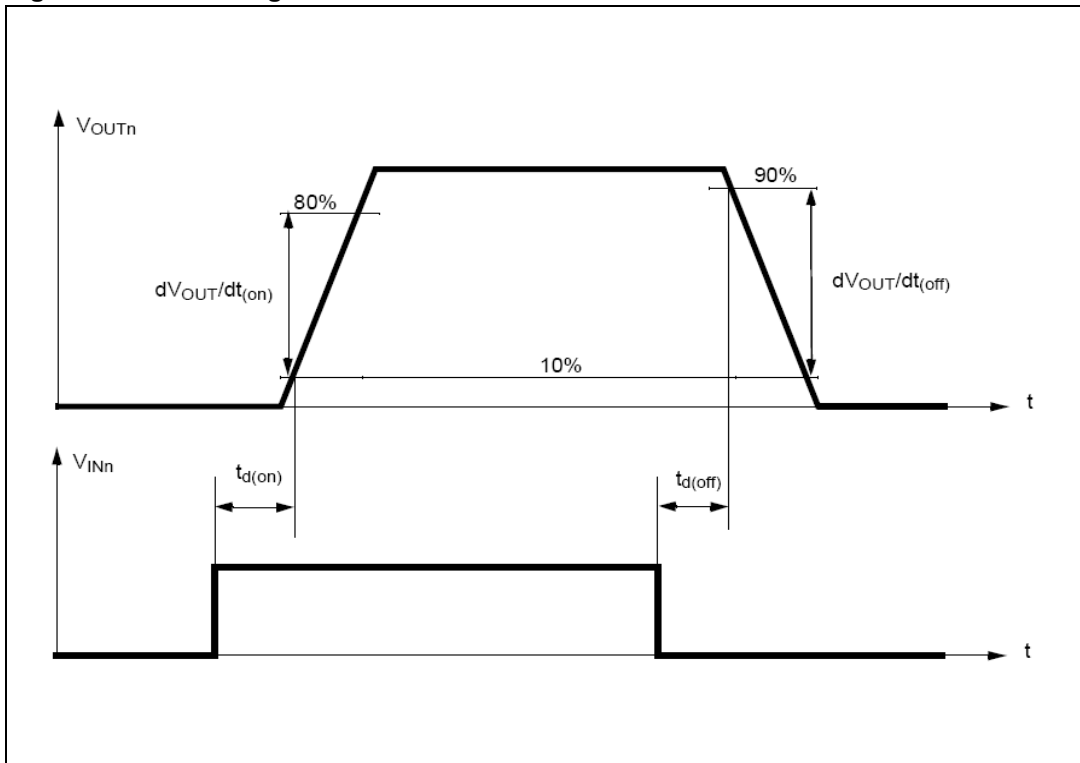

Table 12. Truth table

Conditions	Input	Output	Sense
Normal operation	L	L	H
	H	H	H
Current limitation	L	L	H
	H	X	$(T_j < T_{TSD})$ H $(T_j > T_{TSD})$ L
Overtemperature	L	L	H
	H	L	L
Undervoltage	L	L	X
	H	L	X
Overvoltage	L	L	H
	H	L	H
Output voltage > V_{OL}	L	H	L
	H	H	H
Output current < I_{OL}	L	L	H
	H	H	L

Table 13. Electrical transient requirements on V_{CC} pin (part 1/3)

ISO T/R 7637/1 Test pulse	Test levels				Delays and impedance
	I	II	III	IV	
1	- 25V	- 50V	- 75V	- 100V	2ms, 10Ω
2	+ 25V	+ 50V	+ 75V	+ 100V	0.2ms, 10Ω
3a	- 25V	- 50V	- 100V	- 150V	0.1μs, 50Ω
3b	+ 25V	+ 50V	+ 75V	+ 100V	0.1μs, 50Ω
4	- 4V	- 5V	- 6V	- 7V	100ms, 0.01Ω
5	+ 26.5V	+ 46.5V	+ 66.5V	+ 86.5V	400ms, 2Ω

Table 14. Electrical transient requirements on V_{CC} pin (part 2/3)

ISO T/R 7637/1 Test pulse	Test levels results			
	I	II	III	IV
1	C	C	C	C
2	C	C	C	C
3a	C	C	C	C
3b	C	C	C	C
4	C	C	C	C
5	C	E	E	E

Table 15. Electrical transient requirements on V_{CC} pin (part 3/3)

Class	Contents
C	All functions of the device are performed as designed after exposure to disturbance.
E	One or more functions of the device is not performed as designed after exposure and cannot be returned to proper operation without replacing the device.

Figure 6. Waveforms

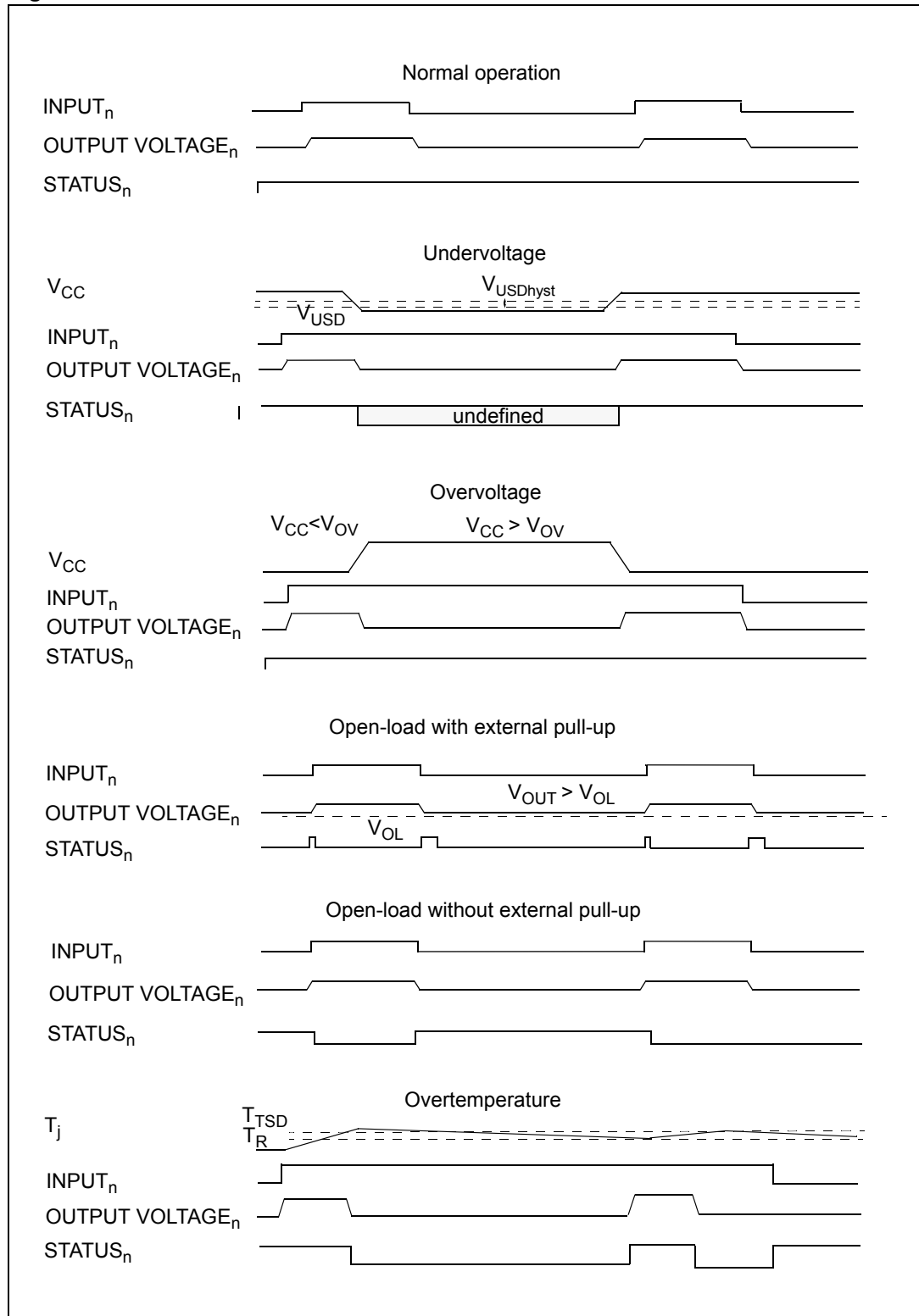

2.4 Electrical characteristics curves

Figure 7. Off-state output current

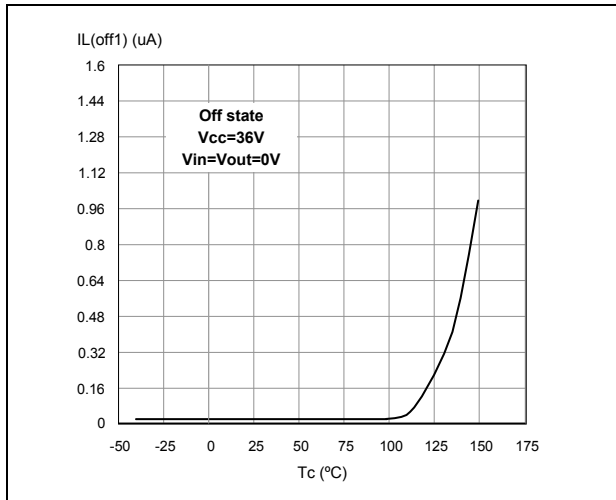

Figure 8. High level input current

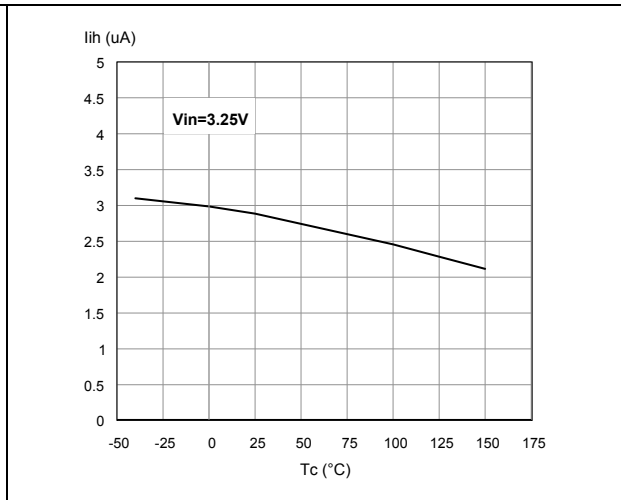

Figure 9. Input clamp voltage

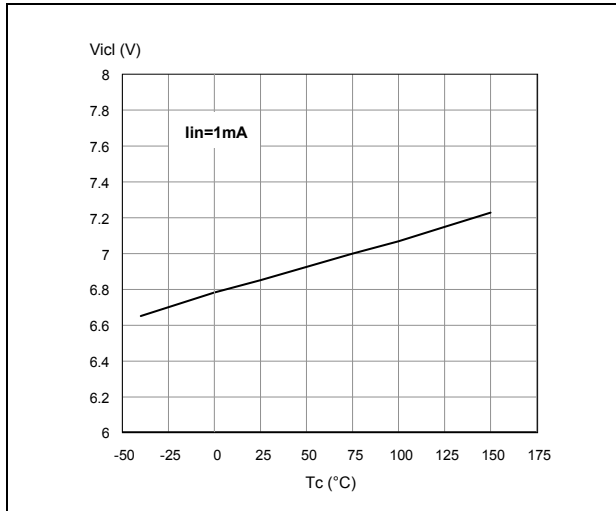

Figure 10. Status leakage current

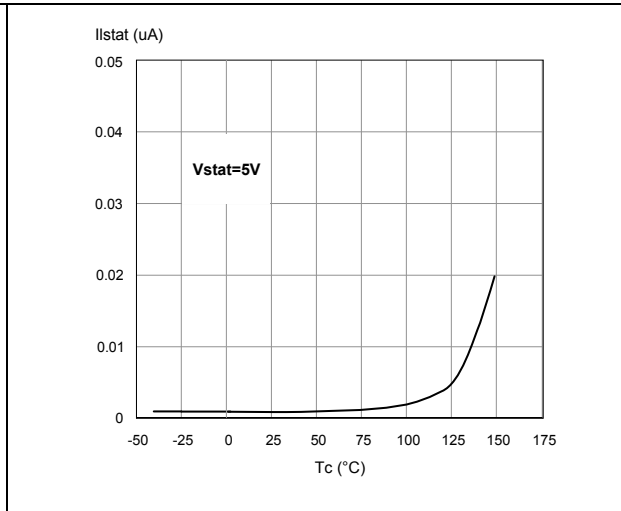

Figure 11. Status low output voltage

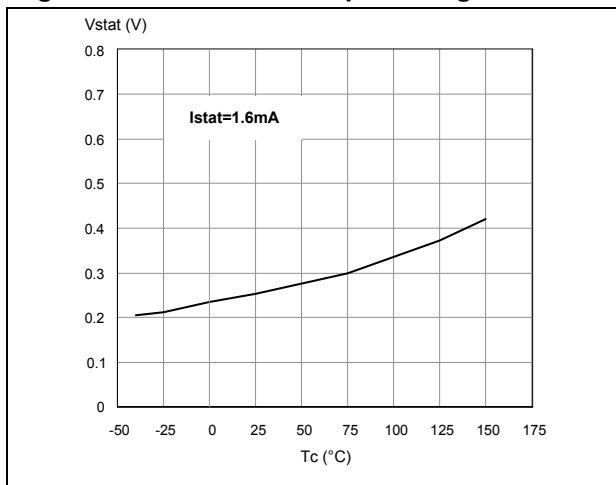

Figure 12. Status clamp voltage

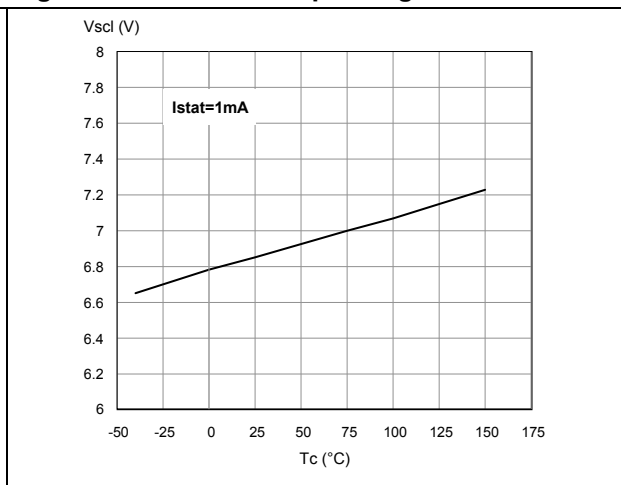

Figure 13. Overvoltage shutdown

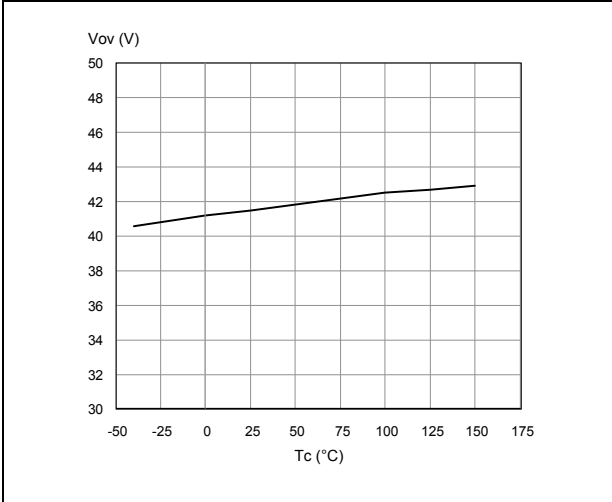

Figure 14. I_{LIM} vs T_{case}

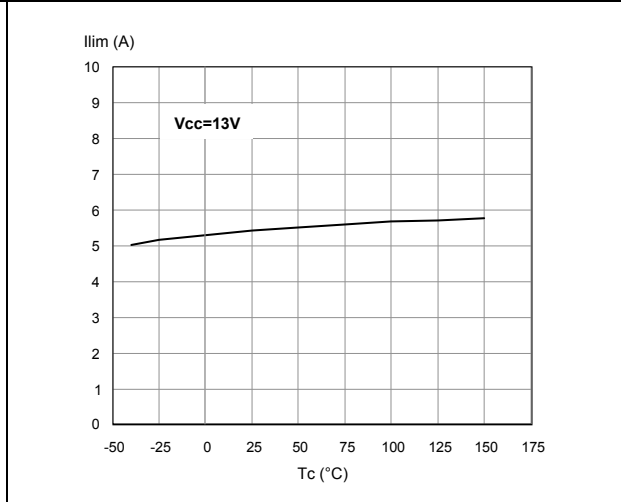

Figure 15. Turn-on voltage slope

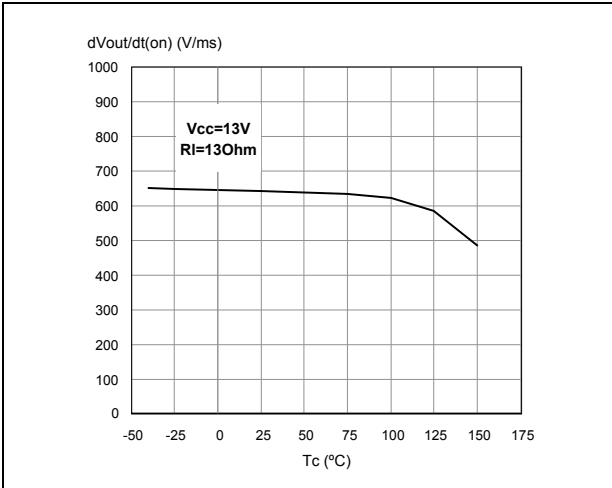

Figure 16. Turn-off voltage slope

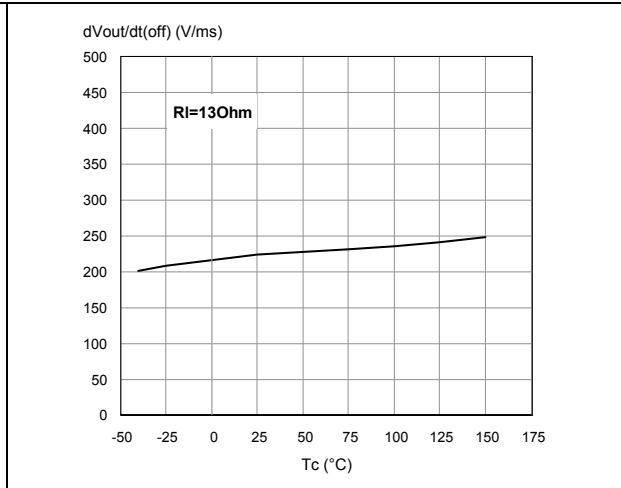

Figure 17. On-state resistance vs T_{case}

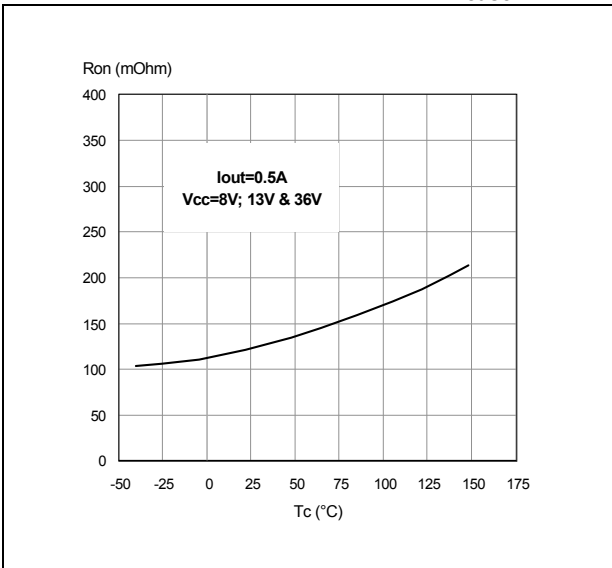

Figure 18. On-state resistance vs V_{CC}

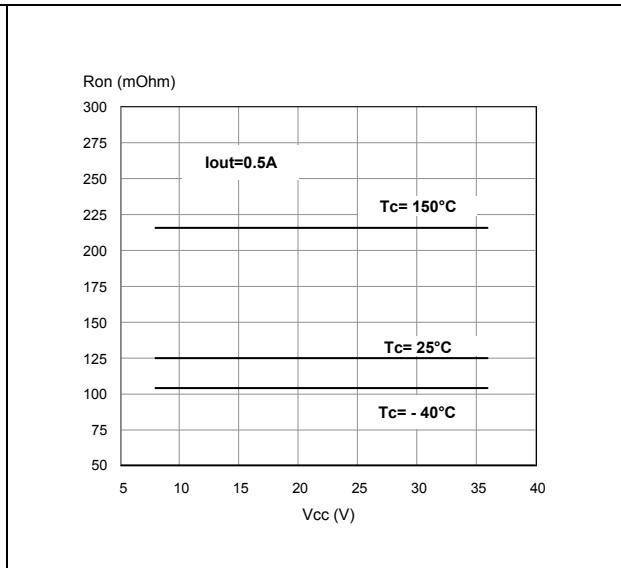

Figure 19. Input high level

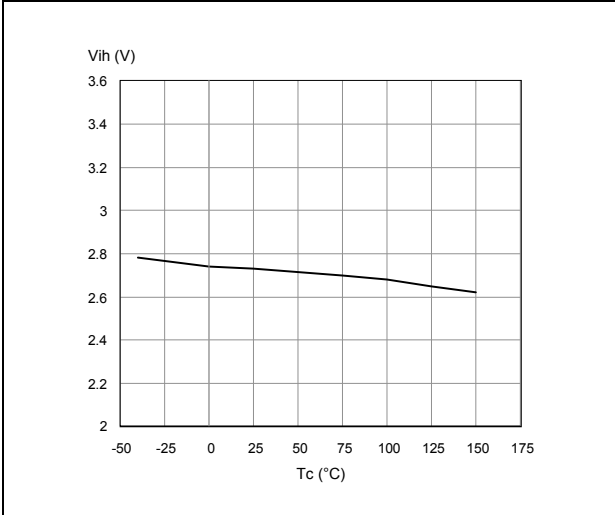

Figure 20. Input low level

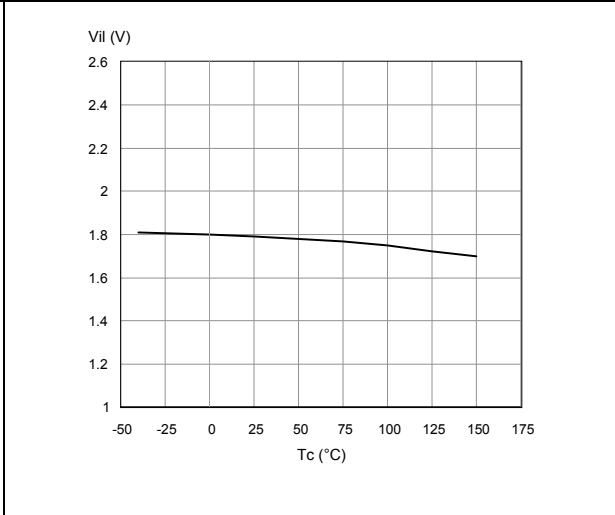

Figure 21. Open-load on-state detection threshold

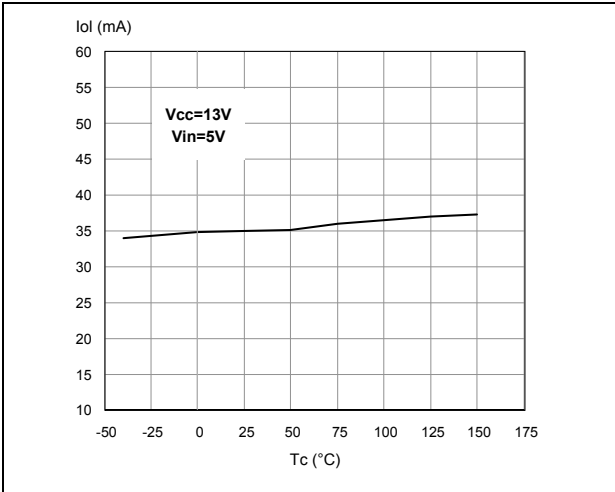

Figure 22. Open-load off-state voltage detection threshold

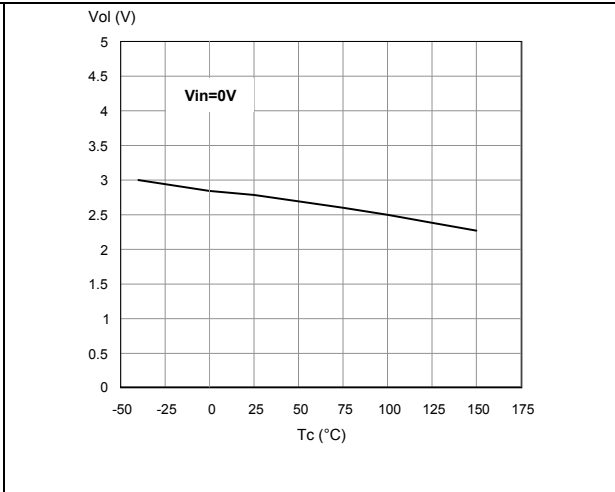
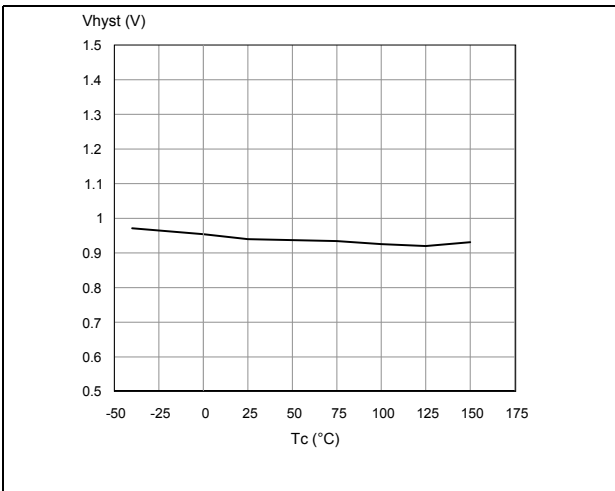
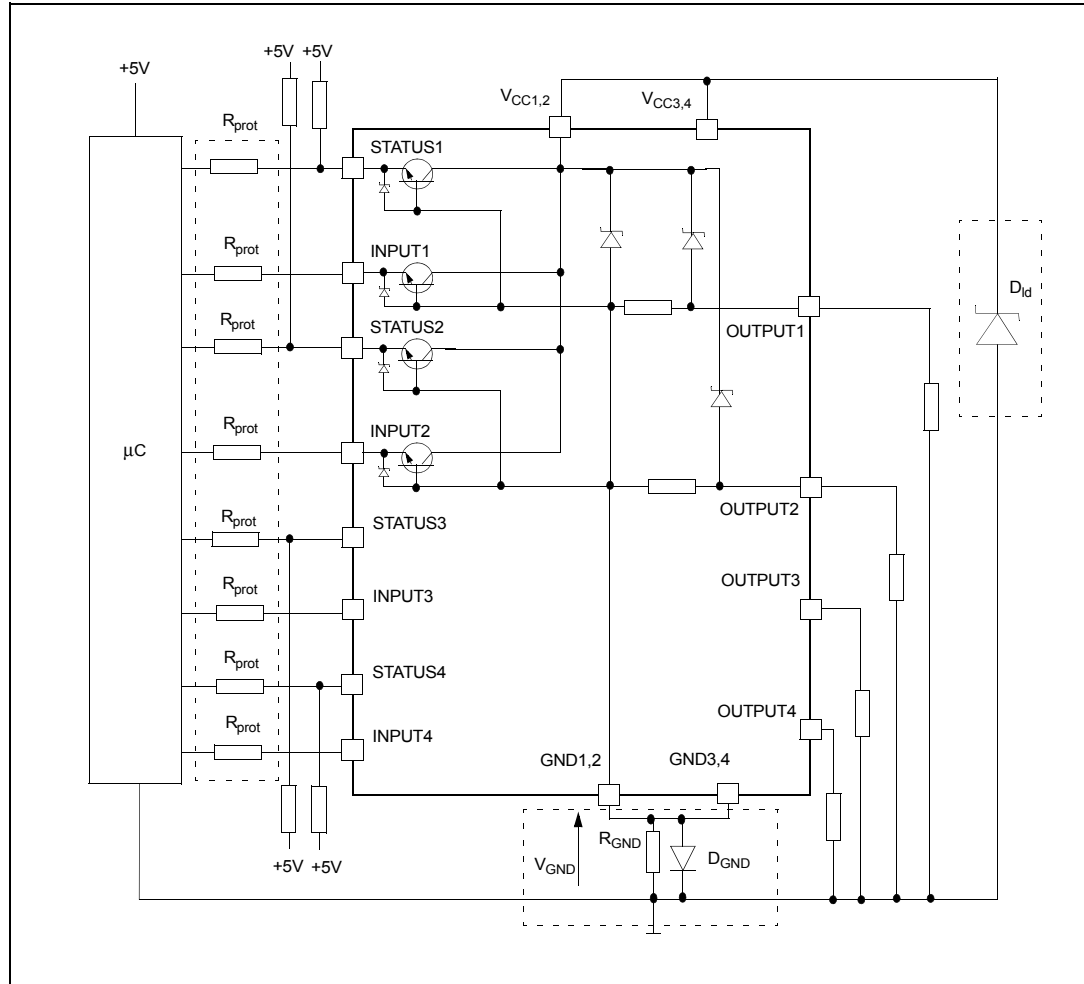

Figure 23. Input hysteresis voltage



3 Application information

Figure 24. Application schematic



Note: Channels 3 and 4 have the same internal circuit as channel 1 and 2.

3.1 GND protection network against reverse battery

This section provides two solutions for implementing a ground protection network against reverse battery.

3.1.1 Solution 1: a resistor in the ground line (R_{GND} only)

It can be used with any type of load.

The following show how to dimension the R_{GND} resistor:

Equation 1

$$R_{GND} \leq 600mV / 2 (I_{S(on)max})$$

Equation 2

$$R_{GND} \geq (-V_{CC}) / (-I_{GND})$$

where $-I_{GND}$ is the DC reverse ground pin current and can be found in the absolute maximum rating section of the device datasheet.

Power dissipation in R_{GND} (when $V_{CC} < 0$ during reverse battery situations) is:

$$P_D = (-V_{CC})^2 / R_{GND}$$

This resistor can be shared amongst several different HSDs. Please note that the value of this resistor should be calculated with [Equation 1](#) where $I_{S(on)max}$ becomes the sum of the maximum on-state currents of the different devices.

Please note that, if the microprocessor ground is not shared by the device ground, then the R_{GND} produces a shift ($I_{S(on)max} * R_{GND}$) in the input thresholds and the status output values. This shift varies depending on how many devices are ON in the case of several high side drivers sharing the same R_{GND} .

If the calculated power dissipation requires the use of a large resistor, or several devices have to share the same resistor, then ST suggests using solution 2 below.

3.1.2 Solution 2: a diode (D_{GND}) in the ground line

A resistor ($R_{GND} = 1k\Omega$) should be inserted in parallel to D_{GND} if the device is driving an inductive load. This small signal diode can be safely shared amongst several different HSD. Also in this case, the presence of the ground network produces a shift ($\approx 600mV$) in the input threshold and the status output values if the microprocessor ground is not common with the device ground. This shift not varies if more than one HSD shares the same diode/resistor network. Series resistor in INPUT and STATUS lines are also required to prevent that, during battery voltage transient, the current exceeds the Absolute Maximum Rating. Safest configuration for unused INPUT and STATUS pin is to leave them unconnected.

3.2 Load dump protection

D_{ld} is necessary (voltage transient suppressor) if the load dump peak voltage exceeds the V_{CC} maximum DC rating. The same applies if the device is subject to transients on the V_{CC} line that are greater than those shown in the ISO T/R 7637/1 table.

3.3 MCU I/O protection

If a ground protection network is used and negative transients are present on the V_{CC} line, the control pins are pulled negative. ST suggests to insert a resistor (R_{prot}) in line to prevent the microcontroller I/O pins from latching up.

The value of these resistors is a compromise between the leakage current of microcontroller and the current required by the HSD I/Os (Input levels compatibility) with the latch-up limit of microcontroller I/Os:

$$-V_{CCpeak} / I_{latchup} \leq R_{prot} \leq (V_{OH\mu C} - V_{IH} - V_{GND}) / I_{IHmax}$$

Example

For the following conditions:

$$V_{CCpeak} = - 100 \text{ V}$$

$$I_{latchup} \geq 20 \text{ mA}$$

$$V_{OH\mu C} \geq 4.5 \text{ V}$$

$$5 \text{ k}\Omega \leq R_{prot} \leq 65 \text{ k}\Omega$$

Recommended values are:

$$R_{prot} = 10 \text{ k}\Omega$$

3.4 Open-load detection in off-state

Off-state open-load detection requires an external pull-up resistor (R_{PU}) connected between output pin and a positive supply voltage (V_{PU}) like the +5V line used to supply the microprocessor.

The external resistor has to be selected according to the following requirements:

1. No false open-load indication when load is connected: in this case we have to avoid V_{OUT} to be higher than V_{OLmin} ; this results in the following condition $V_{OUT} = (V_{PU} / (R_L + R_{PU}))R_L < V_{OLmin}$.
2. No misdetection when load is disconnected: in this case the V_{OUT} has to be higher than V_{OLmax} ; this results in the following condition $R_{PU} < (V_{PU} - V_{OLmax}) / I_{L(off2)}$.

Because $I_{s(OFF)}$ may significantly increase if V_{out} is pulled high (up to several mA), the pull-up resistor R_{PU} should be connected to a supply that is switched OFF when the module is in standby.

The values of V_{OLmin} , V_{OLmax} and $I_{L(off2)}$ are available in [Section 2.3: Electrical characteristics](#).

Figure 25. Open-load detection in off-state

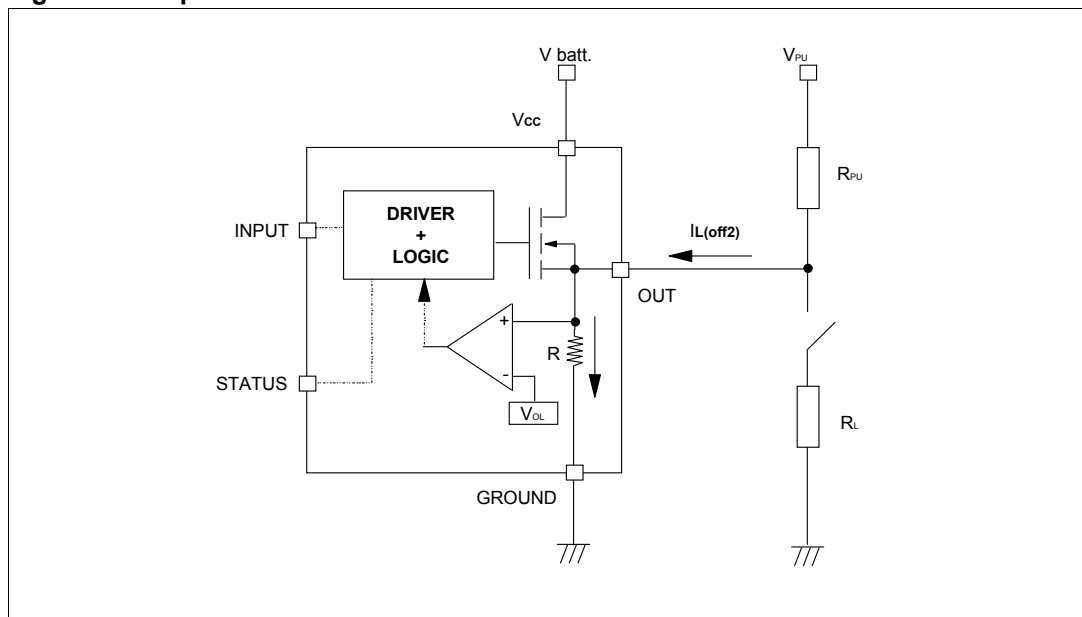

3.5 Maximum demagnetization energy ($V_{CC} = 13.5V$)

Figure 26. SO-28 (double island) maximum turn-off current versus load inductance

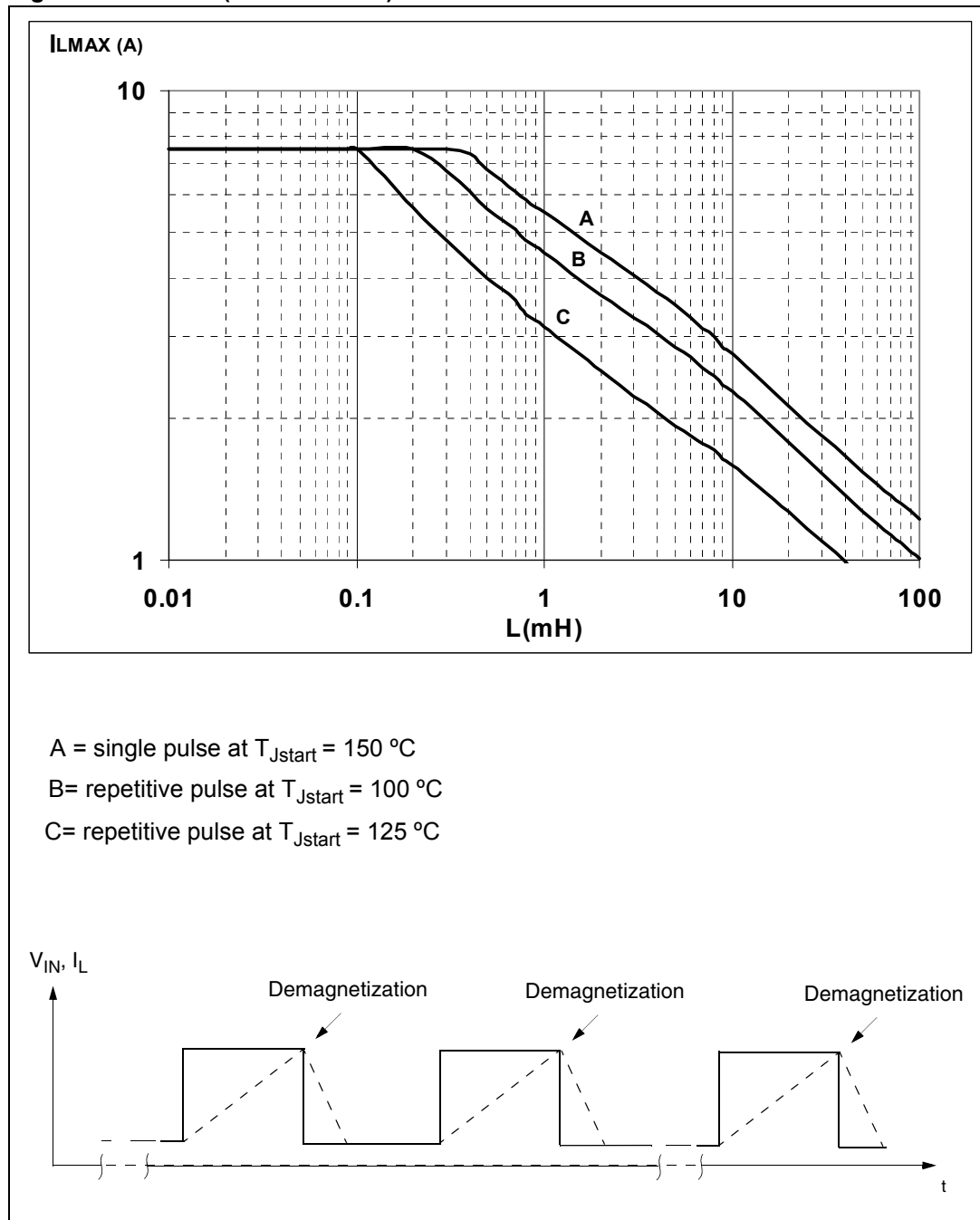

Note: Values are generated with $R_L = 0\Omega$.
 In case of repetitive pulses, T_{Jstart} (at beginning of each demagnetization) of every pulse must not exceed the temperature specified above for curves B and C.

4 Package and PCB thermal data

4.1 SO-28 thermal data

Figure 27. SO-28 double island PC board

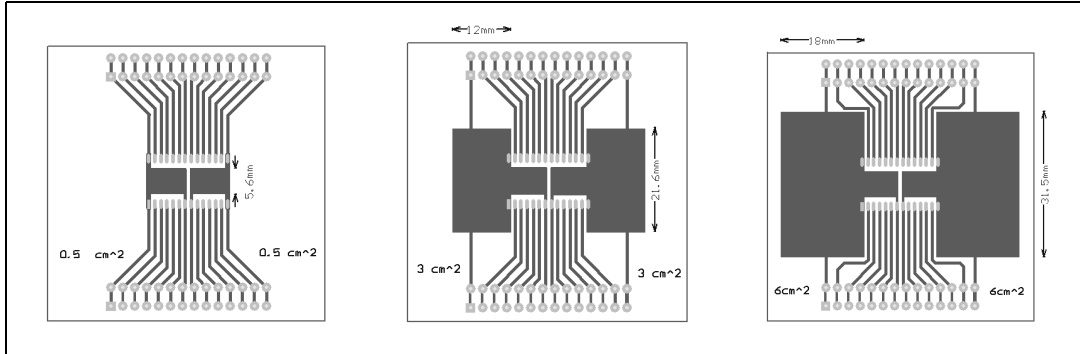

Note: Layout condition of R_{th} and Z_{th} measurements (PCB FR4 area = 58 mm x 58 mm, PCB thickness = 2 mm, Cu thickness = 35 μ m, Copper areas: 0.5 cm², 3 cm², 6 cm²).

Table 16. Thermal calculation according to the PCB heatsink area

Chip 1	Chip 2	T_{jchip1}	T_{jchip2}	Note
ON	OFF	$R_{thA} \times P_{dchip1} + T_{amb}$	$R_{thC} \times P_{dchip1} + T_{amb}$	
OFF	ON	$R_{thC} \times P_{dchip2} + T_{amb}$	$R_{thA} \times P_{dchip2} + T_{amb}$	
ON	ON	$R_{thB} \times (P_{dchip1} + P_{dchip2}) + T_{amb}$	$R_{thB} \times (P_{dchip1} + P_{dchip2}) + T_{amb}$	$P_{dchip1} = P_{dchip2}$
ON	ON	$(R_{thA} \times P_{dchip1}) + R_{thC} \times P_{dchip2} + T_{amb}$	$(R_{thA} \times P_{dchip2}) + R_{thC} \times P_{dchip1} + T_{amb}$	$P_{dchip1} \neq P_{dchip2}$

R_{thA} = thermal resistance junction to ambient with one chip ON

R_{thB} = thermal resistance junction to ambient with both chips ON and $P_{dchip1} = P_{dchip2}$

R_{thC} = mutual thermal resistance

Figure 28. $R_{thj-amb}$ vs PCB copper area in open box free air condition

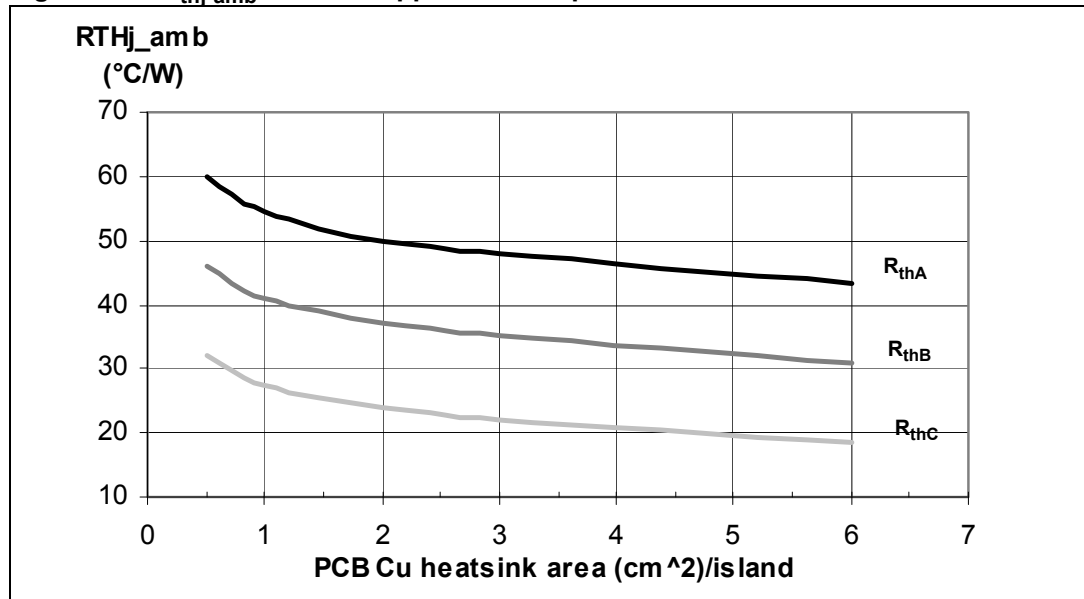
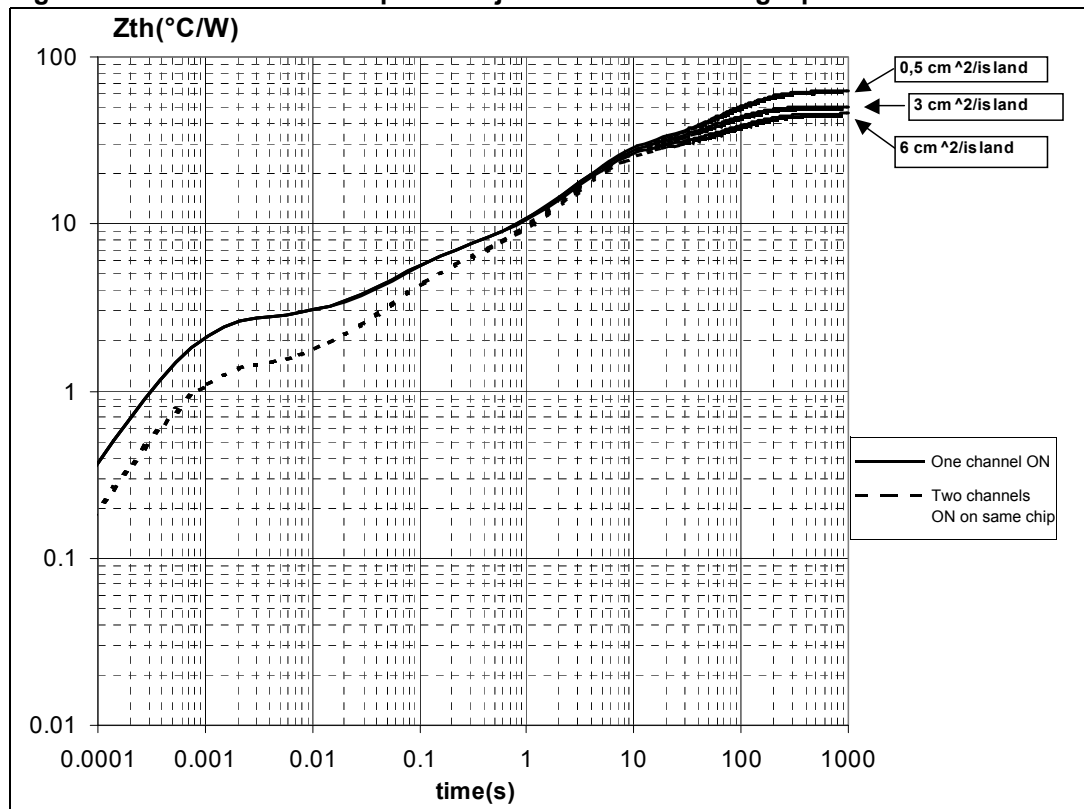

Figure 29. SO-28 thermal impedance junction ambient single pulse



Equation 3: pulse calculation formula

$$Z_{TH\delta} = R_{TH} \cdot \delta + Z_{THtp}(1 - \delta)$$

where $\delta = t_p/T$

Figure 30. Thermal fitting model of a quad channel HSD in SO-28

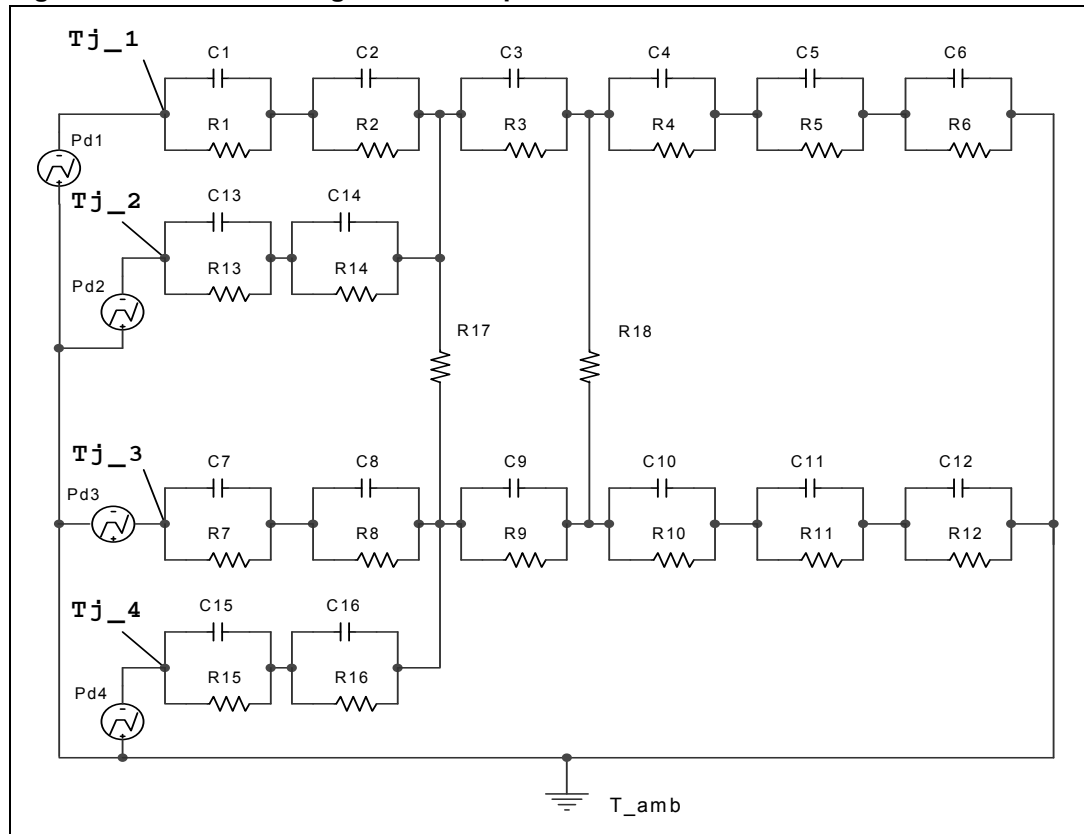

Table 17. Thermal parameters

Area / island (cm ²)	0.5	6
R1 = R7 = R13 = R15 (°C/W)	0.35	
R2 = R8 = R14 = R16 (°C/W)	1.8	
R3 = R9 (°C/W)	4.5	
R4 = R10 (°C/W)	11	
R5 = R11 (°C/W)	15	
R6 = R12 (°C/W)	30	13
C1 = C7 = C13 = C15 (W.s/°C)	0.0001	
C2 = C8 = C14 = C16 (W.s/°C)	7E-04	
C3 = C9 (W.s/°C)	6E-03	
C4 = C10 (W.s/°C)	0.2	
C5 = C11 (W.s/°C)	1.5	
C6 = C12 (W.s/°C)	5	8
R17 = R18 (°C/W)	150	

5 Package and packing information

5.1 ECOPACK® packages

In order to meet environmental requirements, ST offers these devices in different grades of ECOPACK® packages, depending on their level of environmental compliance. ECOPACK® specifications, grade definitions and product status are available at: www.st.com.

ECOPACK® is an ST trademark.

5.2 SO-28 package information

Figure 31. SO-28 package dimensions

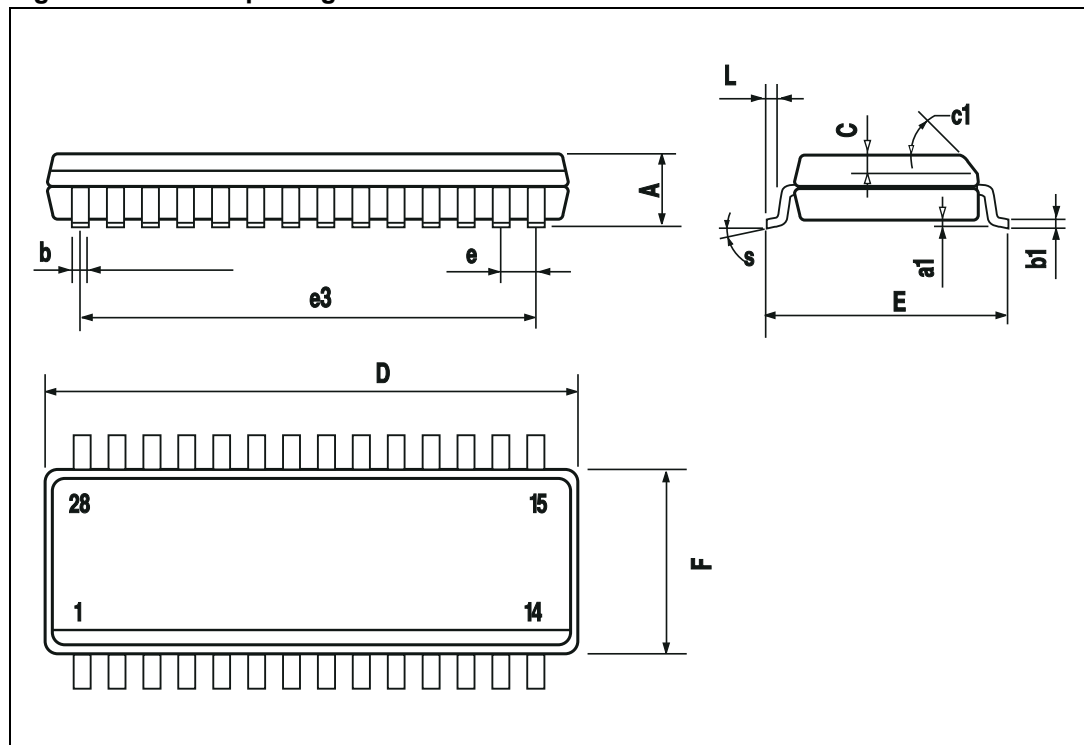

Table 18. SO-28 mechanical data

Symbol	Millimeters		
	Min.	Typ.	Max.
A			2.65
a1	0.10		0.30
b	0.35		0.49
b1	0.23		0.32
C		0.50	
c1	45° (typ.)		
D	17.7		18.1
E	10.00		10.65
e		1.27	
e3		16.51	
F	7.40		7.60
L	0.40		1.27
S	8° (max.)		

5.3 SO-28 packing information

Figure 32. SO-28 tube shipment (no suffix)

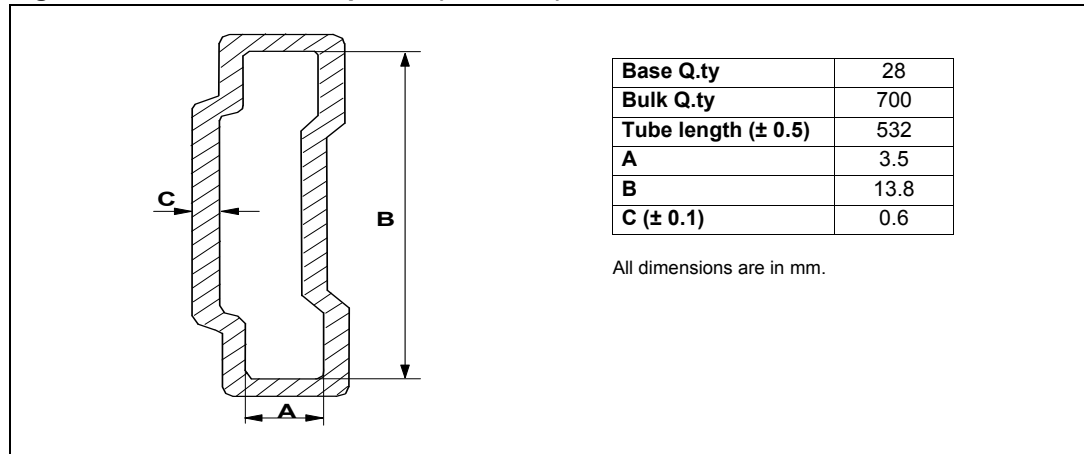
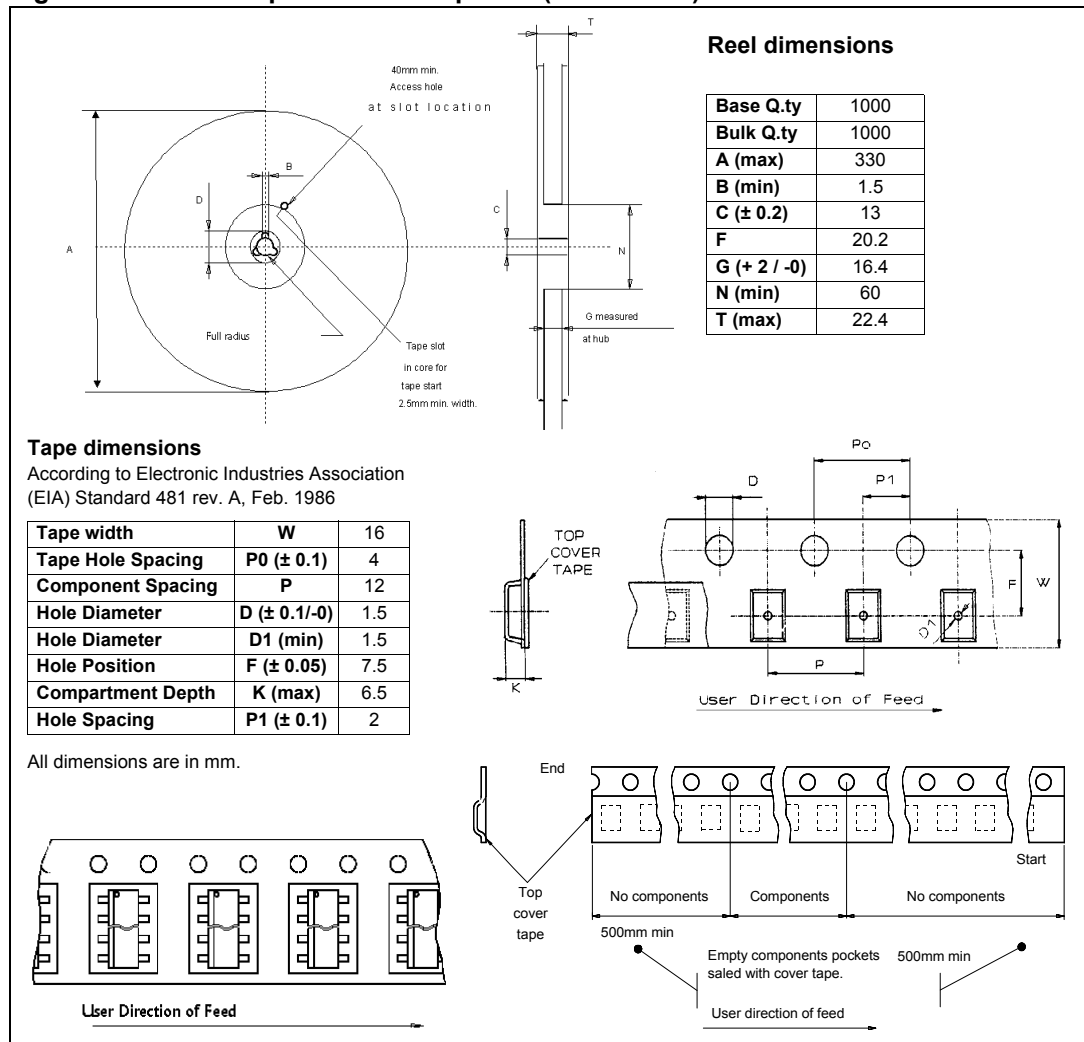

Figure 33. SO-28 tape and reel shipment (suffix "TR")



6 Revision history

Table 19. Document revision history

Date	Revision	Changes
27-Apr-2010	1	Initial release.
19-Sep-2013	2	Updated Disclaimer

Please Read Carefully:

Information in this document is provided solely in connection with ST products. STMicroelectronics NV and its subsidiaries ("ST") reserve the right to make changes, corrections, modifications or improvements, to this document, and the products and services described herein at any time, without notice.

All ST products are sold pursuant to ST's terms and conditions of sale.

Purchasers are solely responsible for the choice, selection and use of the ST products and services described herein, and ST assumes no liability whatsoever relating to the choice, selection or use of the ST products and services described herein.

No license, express or implied, by estoppel or otherwise, to any intellectual property rights is granted under this document. If any part of this document refers to any third party products or services it shall not be deemed a license grant by ST for the use of such third party products or services, or any intellectual property contained therein or considered as a warranty covering the use in any manner whatsoever of such third party products or services or any intellectual property contained therein.

UNLESS OTHERWISE SET FORTH IN ST'S TERMS AND CONDITIONS OF SALE ST DISCLAIMS ANY EXPRESS OR IMPLIED WARRANTY WITH RESPECT TO THE USE AND/OR SALE OF ST PRODUCTS INCLUDING WITHOUT LIMITATION IMPLIED WARRANTIES OF MERCHANTABILITY, FITNESS FOR A PARTICULAR PURPOSE (AND THEIR EQUIVALENTS UNDER THE LAWS OF ANY JURISDICTION), OR INFRINGEMENT OF ANY PATENT, COPYRIGHT OR OTHER INTELLECTUAL PROPERTY RIGHT.

ST PRODUCTS ARE NOT DESIGNED OR AUTHORIZED FOR USE IN: (A) SAFETY CRITICAL APPLICATIONS SUCH AS LIFE SUPPORTING, ACTIVE IMPLANTED DEVICES OR SYSTEMS WITH PRODUCT FUNCTIONAL SAFETY REQUIREMENTS; (B) AERONAUTIC APPLICATIONS; (C) AUTOMOTIVE APPLICATIONS OR ENVIRONMENTS, AND/OR (D) AEROSPACE APPLICATIONS OR ENVIRONMENTS. WHERE ST PRODUCTS ARE NOT DESIGNED FOR SUCH USE, THE PURCHASER SHALL USE PRODUCTS AT PURCHASER'S SOLE RISK, EVEN IF ST HAS BEEN INFORMED IN WRITING OF SUCH USAGE, UNLESS A PRODUCT IS EXPRESSLY DESIGNATED BY ST AS BEING INTENDED FOR "AUTOMOTIVE, AUTOMOTIVE SAFETY OR MEDICAL" INDUSTRY DOMAINS ACCORDING TO ST PRODUCT DESIGN SPECIFICATIONS. PRODUCTS FORMALLY ESCC, QML OR JAN QUALIFIED ARE DEEMED SUITABLE FOR USE IN AEROSPACE BY THE CORRESPONDING GOVERNMENTAL AGENCY.

Resale of ST products with provisions different from the statements and/or technical features set forth in this document shall immediately void any warranty granted by ST for the ST product or service described herein and shall not create or extend in any manner whatsoever, any liability of ST.

ST and the ST logo are trademarks or registered trademarks of ST in various countries.

Information in this document supersedes and replaces all information previously supplied.

The ST logo is a registered trademark of STMicroelectronics. All other names are the property of their respective owners.

© 2013 STMicroelectronics - All rights reserved



STMicroelectronics group of companies

Australia - Belgium - Brazil - Canada - China - Czech Republic - Finland - France - Germany - Hong Kong - India - Israel - Italy - Japan - Malaysia - Malta - Morocco - Philippines - Singapore - Spain - Sweden - Switzerland - United Kingdom - United States of America



www.st.com

Looking for pricing, stock, or lifecycle information?

Click below to explore more details on WIN SOURCE:

-  [View VNQ810P-E on WIN SOURCE](#)
-  [STMicroelectronics](#) Information

Optimize Your Supply Chain with WIN SOURCE Solutions

-  Global Sourcing Solution
-  Obsolete Management
-  Cost Control Management
-  Shortage Management
-  Alternative Solution
-  Excess Inventory Management