



**THE DATASHEET OF
MT28F008B3VG-9 T**



FLASH MEMORY

MT28F008B3
MT28F800B3

3V ONLY, DUAL SUPPLY (SMART 3)

FEATURES

- Eleven erase blocks:
16KB/8K-word boot block (protected)
Two 8KB/4K-word parameter blocks
Eight main memory blocks
- Smart 3 technology (B3):
3.3V ±0.3V VCC
3.3V ±0.3V VPP application programming
5V ±10% VPP application/production programming¹
- Compatible with 0.3µm Smart 3 device
- Advanced 0.18µm CMOS floating-gate process
- Address access time: 90ns
- 100,000 ERASE cycles
- Industry-standard pinouts
- Inputs and outputs are fully TTL-compatible
- Automated write and erase algorithm
- Two-cycle WRITE/ERASE sequence
- TSOP, SOP and FBGA packaging options
- Byte- or word-wide READ and WRITE
(MT28F800B3): 1 Meg x 8/512K x 16

Options

- Timing
90ns access
- Configurations
1 Meg x 8
512K x 16/1 Meg x 8
- Boot Block Starting Word Address
Top (7FFFh)
Bottom (0000h)
- Operating Temperature Range
Commercial (0°C to +70°C)
Extended (-40°C to +85°C)
- Packages
MT28F008B3
Plastic 40-pin (standard) TSOP Type I
Plastic 40-pin (lead free) TSOP Type I
MT28F800B3
Plastic 48-pin (standard) TSOP Type I
Plastic 48-pin (lead free) TSOP Type I
Plastic 44-pin (standard) SOP
Plastic 44-pin (lead free) SOP

Marking

-9

MT28F008B3
MT28F800B3

T
B

None
ET

VG
VP

WG
WP
SG²
SP²

- NOTE: 1. This generation of devices does not support 12V VPP production programming; however, 5V VPP application production programming can be used with no loss of performance.
2. Contact Factory for availability

Part Number Example:
MT28F800B3WG-9

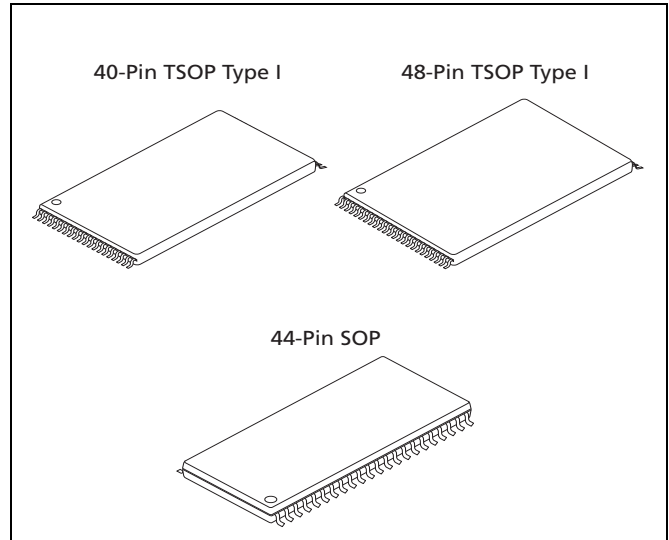

GENERAL DESCRIPTION

The MT28F008B3 (x8) and MT28F800B3 (x16/x8) are low-voltage, nonvolatile, electrically block-erasable (flash), programmable memory devices containing 8,388,608 bits organized as 524,288 words (16 bits) or 1,048,576 bytes (8 bits). Writing and erasing the device is done with a VPP voltage of either 3.3V or 5V, while all operations are performed with a 3.3V VCC. Due to process technology advances, 5V VPP is optimal for application and production programming. These devices are fabricated with Micron's advanced 0.18µm CMOS floating-gate process.

The MT28F008B3 and MT28F800B3 are organized into eleven separately erasable blocks. To ensure that critical firmware is protected from accidental erasure or overwrite, the devices feature a hardware-protected boot block. This block may be used to store code implemented in low-level system recovery. The remaining blocks vary in density and are written and erased with no additional security measures.

Refer to Micron's Web site (www.micron.com/flash) for the latest data sheet.

Figure 1: Pin Assignment (Top View)

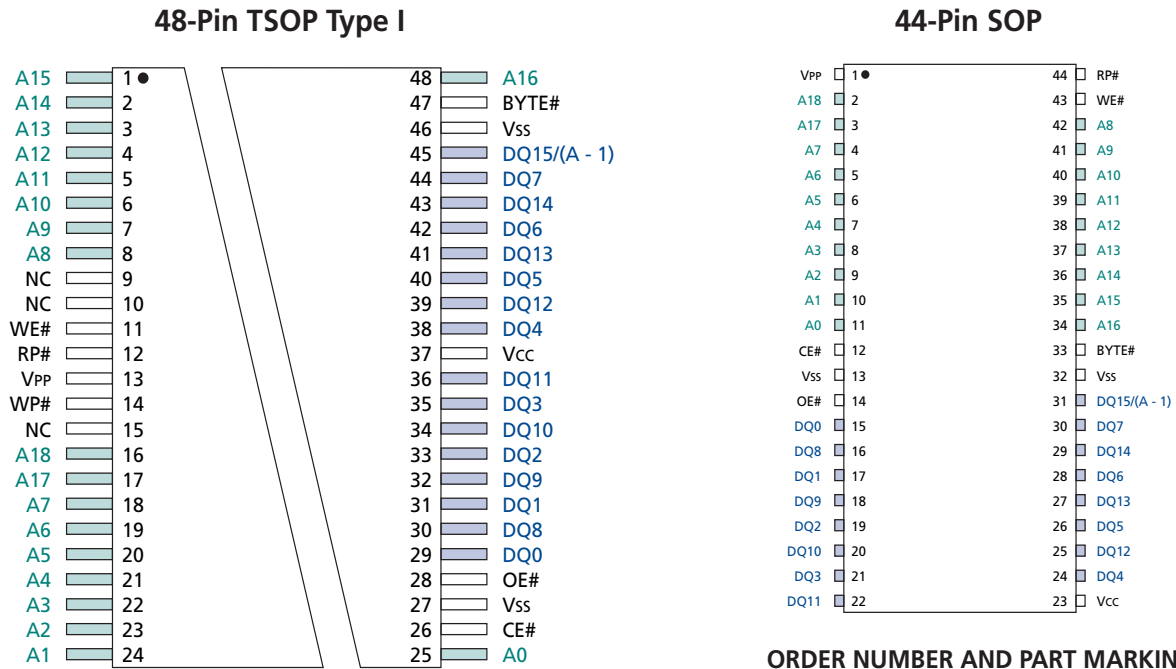

ORDER NUMBER AND PART MARKING

MT28F800B3WG-9 B MT28F800B3WP-9 B
 MT28F800B3WG-9 T MT28F800B3WP-9 T
 MT28F800B3WG-9 BET MT28F800B3WP-9 BET
 MT28F800B3WG-9 TET MT28F800B3WP-9 TET

ORDER NUMBER AND PART MARKING

MT28F800B3SG-9 B MT28F800B3SP-9 B
 MT28F800B3SG-9 T MT28F800B3SP-9 T
 MT28F800B3SG-9 BET MT28F800B3SP-9 BET
 MT28F800B3SG-9 TET MT28F800B3SP-9 TET

40-Pin TSOP Type I

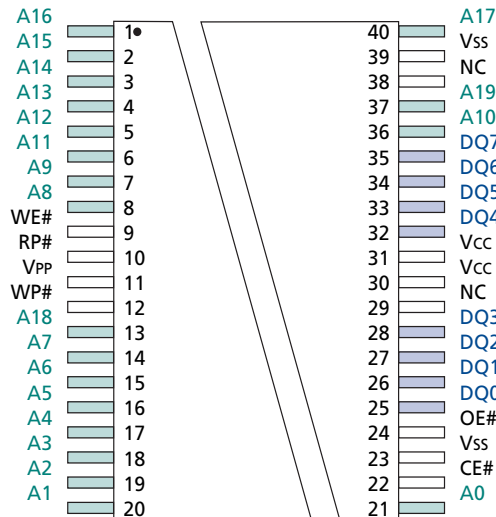

ORDER NUMBER AND PART MARKING

MT28F008B3VG-9 B MT28F008B3VP-9 B
 MT28F008B3VG-9 T MT28F008B3VP-9 T
 MT28F008B3VG-9 BET MT28F008B3VP-9 BET
 MT28F008B3VG-9 TET MT28F008B3VP-9 TET

Table 1: Pin Descriptions

44-PIN SOP NUMBERS	40-PIN TSOP NUMBERS	48-PIN TSOP NUMBERS	SYMBOL	TYPE	DESCRIPTION
43	9	11	WE#	Input	Write Enable: Determines if a given cycle is a WRITE cycle. If WE# is LOW, the cycle is either a WRITE to the command execution logic (CEL) or to the memory array.
–	12	14	WP#	Input	Write Protect: Unlocks the boot block when HIGH if VPP = VPPH1 (3.3V) or VPPH2 (5V) and RP# = VIH during a WRITE or ERASE. Does not affect WRITE or ERASE operation on other blocks.
12	22	26	CE#	Input	Chip Enable: Activates the device when LOW. When CE# is HIGH, the device is disabled and goes into standby power mode.
44	10	12	RP#	Input	Reset/Power-Down: When LOW, RP# clears the status register, sets the internal state machine (ISM) to the array read mode and places the device in deep power-down mode. All inputs, including CE#, are "Don't Care," and all outputs are High-Z. RP# unlocks the boot block and overrides the condition of WP# when at VHH (12V), and must be held at VIH during all other modes of operation.
14	24	28	OE#	Input	Output Enable: Enables data output buffers when LOW. When OE# is HIGH, the output buffers are disabled.
33	–	47	BYTE#	Input	Byte Enable: If BYTE# = HIGH, the upper byte is active through DQ8–DQ15. If BYTE# = LOW, DQ8–DQ14 are High-Z, and all data is accessed through DQ0–DQ7. DQ15/(A-1) becomes the least significant address input.
11, 10, 9, 8, 7, 6, 5, 4, 42, 41, 40, 39, 38, 37, 36, 35, 34, 3, 2	21, 20, 19, 18, 17, 16, 15, 14, 8, 7, 36, 6, 5, 4, 3, 2, 1, 40, 13, 37	25, 24, 23, 22, 21, 20, 19, 18, 8, 7, 6, 5, 4, 3, 2, 1, 48, 17, 16	A0–A18/ (A19)	Input	Address Inputs: Select a unique 16-bit word or 8-bit byte. The DQ15/(A-1) input becomes the lowest order address when BYTE# = LOW (MT28F800B3) to allow for a selection of an 8-bit byte from the 1,048,576 available.
31	–	45	DQ15/ (A-1)	Input/ Output	Data I/O: MSB of data when BYTE# = HIGH. Address Input: LSB of address input when BYTE# = LOW during READ or WRITE operation.
15, 17, 19, 21, 24, 26, 28, 30	25, 26, 27, 28, 32, 33, 34, 35	29, 31, 33, 35, 38, 40, 42, 44	DQ0– DQ7	Input/ Output	Data I/Os: Data output pins during any READ operation or data input pins during a WRITE. These pins are used to input commands to the CEL.
16, 18, 20, 22, 25, 27, 29	–	30, 32, 34, 36, 39, 41, 43	DQ8– DQ14	Input/ Output	Data I/Os: Data output pins during any READ operation or data input pins during a WRITE when BYTE# = HIGH. These pins are High-Z when BYTE# is LOW.
1	11	13	VPP	Supply	Write/Erase Supply Voltage: From a WRITE or ERASE CONFIRM until completion of the WRITE or ERASE, VPP must be at VPPH1 (3.3V) or VPPH2 (5V). VPP = "Don't Care" during all other operations.
23	30, 31	37	Vcc	Supply	Power Supply: +3.3V ±0.3V.
13, 32	23, 39	27, 46	Vss	Supply	Ground.
–	29, 38	9, 10, 15	NC	–	NoConnect: These pins may be driven or left unconnected.

Table 2: Truth Table (MT28F800B3)¹

FUNCTION	RP#	CE#	OE#	WE#	WP#	BYTE#	A0	A9	Vpp	DQ0–DQ7	DQ8–DQ14	DQ15/A-1
Standby	H	H	X	X	X	X	X	X	X	High-Z	High-Z	High-Z
RESET	L	X	X	X	X	X	X	X	X	High-Z	High-Z	High-Z
READ												
READ (word mode)	H	L	L	H	X	H	X	X	X	Data-Out	Data-Out	Data-Out
READ (byte mode)	H	L	L	H	X	L	X	X	X	Data-Out	High-Z	A-1
Output Disable	H	L	H	H	X	X	X	X	X	High-Z	High-Z	High-Z
WRITE/ERASE (EXCEPT BOOT BLOCK)²												
ERASE SETUP	H	L	H	L	X	X	X	X	X	20h	X	X
ERASE CONFIRM ³	H	L	H	L	X	X	X	X	VppH	D0h	X	X
WRITE SETUP	H	L	H	L	X	X	X	X	X	10h/40h	X	X
WRITE (word mode) ⁴	H	L	H	L	X	H	X	X	VppH	Data-In	Data-In	Data-In
WRITE (byte mode) ⁴	H	L	H	L	X	L	X	X	VppH	Data-In	X	A-1
READ ARRAY ⁵	H	L	H	L	X	X	X	X	X	FFh	X	X
WRITE/ERASE (BOOT BLOCK)^{2, 7}												
ERASE SETUP	H	L	H	L	X	X	X	X	X	20h	X	X
ERASE CONFIRM ³	VHH	L	H	L	X	X	X	X	VppH	D0h	X	X
ERASE CONFIRM ^{3, 6}	H	L	H	L	H	X	X	X	VppH	D0h	X	X
WRITE SETUP	H	L	H	L	X	X	X	X	X	10h/40h	X	X
WRITE (word mode) ⁴	VHH	L	H	L	X	H	X	X	VppH	Data-In	Data-In	Data-In
WRITE (word mode) ^{4, 6}	H	L	H	L	H	H	X	X	VppH	Data-In	Data-In	Data-In
WRITE (byte mode) ⁴	VHH	L	H	L	X	L	X	X	VppH	Data-In	X	A-1
WRITE (byte mode) ^{4, 6}	H	L	H	L	H	L	X	X	v	Data-In	X	A-1
READ ARRAY ⁵	H	L	H	L	X	X	X	X	X	FFh	X	X
DEVICE IDENTIFICATION^{8, 9}												
Manufacturer Compatibility (word mode) ¹⁰	H	L	L	H	X	H	L	VID	X	89h	00h	–
Manufacturer Compatibility (byte mode)	H	L	L	H	X	L	L	VID	X	89h	High-Z	X
Device (word mode, top boot) ¹⁰	H	L	L	H	X	H	H	VID	X	9Ch	88h	–
Device (byte mode, top boot)	H	L	L	H	X	L	H	VID	X	9Ch	High-Z	X
Device (word mode, bottom boot) ¹⁰	H	L	L	H	X	H	H	VID	X	9Dh	88h	–
Device (byte mode, bottom boot)	H	L	L	H	X	L	H	VID	X	9Dh	High-Z	X

NOTE:

- L = VIL (LOW), H = VIH (HIGH), X = VIL or VIH (“Don’t Care”).
- VppH = VppH1 = 3.3V or VppH2 = 5V.
- Operation must be preceded by ERASE SETUP command.
- Operation must be preceded by WRITE SETUP command.
- The READ ARRAY command must be issued before reading the array after writing or erasing.
- When WP# = VIH, RP# may be at VIH or VHH.
- VHH = 12V.
- VID = 12V; may also be read by issuing the IDENTIFY DEVICE command.
- A1–A8, A10–A18 = VIL.
- Value reflects DQ8–DQ15.

Table 3: Truth Table (MT28F008B3)¹

FUNCTION	RP#	CE#	OE#	WE#	WP#	A0	A9	VPP	DQ0-DQ7
Standby	H	H	X	X	X	X	X	X	High-Z
RESET	L	X	X	X	X	X	X	X	High-Z
READ									
READ	H	L	L	H	X	X	X	X	Data-Out
Output Disable	H	L	H	H	X	X	X	X	High-Z
WRITE/ERASE (EXCEPT BOOT BLOCK)²									
ERASE SETUP	H	L	H	L	X	X	X	X	20h
ERASE CONFIRM ³	H	L	H	L	X	X	X	VPPH	D0h
WRITE SETUP	H	L	H	L	X	X	X	X	10h/40h
WRITE ⁴	H	L	H	L	X	X	X	VPPH	Data-In
READ ARRAY ⁵	H	L	H	L	X	X	X	X	FFh
WRITE/ERASE (BOOT BLOCK)^{2, 7}									
ERASE SETUP	H	L	H	L	X	X	X	X	20h
ERASE CONFIRM ³	VHH	L	H	L	X	X	X	VPPH	D0h
ERASE CONFIRM ^{3, 6}	H	L	H	L	H	X	X	VPPH	D0h
WRITE SETUP	H	L	H	L	X	X	X	X	10h/40h
WRITE ⁴	VHH	L	H	L	X	X	X	VPPH	Data-In
WRITE ^{4, 6}	H	L	H	L	H	X	X	VPPH	Data-In
READ ARRAY ⁵	H	L	H	L	X	X	X	X	FFh
DEVICE IDENTIFICATION^{8, 9}									
Manufacturer Compatibility	H	L	L	H	X	L	VID	X	89h
Device (top boot)	H	L	L	H	X	H	VID	X	98h
Device (bottom boot)	H	L	L	H	X	H	VID	X	99h

NOTE:

1. L = V_{IL}, H = V_{IH}, X = V_{IL} or V_{IH}.
2. V_{PPH} = V_{PPH1} = 3.3V or V_{PPH2} = 5V.
3. Operation must be preceded by ERASE SETUP command.
4. Operation must be preceded by WRITE SETUP command.
5. The READ ARRAY command must be issued before reading the array after writing or erasing.
6. When WP# = V_{IH}, RP# may be at V_{IH} or V_{HH}.
7. V_{HH} = 12V.
8. VID = 12V; may also be read by issuing the IDENTIFY DEVICE command.
9. A1-A8, A10-A19 = V_{IL}.

Functional Description

The MT28F800B3 and MT28F008B3 Flash devices incorporate a number of features ideally suited for system firmware. The memory array is segmented into individual erase blocks. Each block may be erased without affecting data stored in other blocks. These memory blocks are read, written and erased with commands to the command execution logic (CEL). The CEL controls the operation of the internal state machine (ISM), which completely controls all WRITE, BLOCK ERASE and VERIFY operations. The ISM protects each memory location from over-erasure and optimizes each memory location for maximum data retention. In addition, the ISM greatly simplifies the control necessary for writing the device insystem or in an external programmer.

The Functional Description provides detailed information on the operation of the MT28F800B3 and MT28F008B3 and is organized into these sections:

- Overview
- Memory Architecture
- Output (READ) Operations
- Input Operations
- Command Set
- ISM Status Register
- Command Execution
- Error Handling
- WRITE/ERASE Cycle Endurance
- Power Usage
- Power-Up

Overview

Smart 3 Technology (B3)

Smart 3 operation allows maximum flexibility for insystem READ, WRITE and ERASE operations. WRITE and ERASE operations may be executed with a VPP voltage of 3.3V or 5V. Due to process technology advances, 5V VPP is optimal for application and production programming.

Eleven Independently Erasable Memory Blocks

The MT28F800B3 and MT28F008B3 are organized into eleven independently erasable memory blocks that allow portions of the memory to be erased without affecting the rest of the memory data. A special boot block is hardware-protected against inadvertent erasure or writing by requiring either a super-voltage on the RP# pin or driving the WP# pin HIGH. (The WP# pin does not apply to the SOP package.) One of these two conditions must exist along with the VPP voltage

(3.3V or 5V) on the VPP pin before a WRITE or ERASE is performed on the boot block. The remaining blocks require that only the VPP voltage be present on the VPP pin before writing or erasing.

Hardware-Protected Boot block

This block of the memory array can be erased or written only when the RP# pin is taken to VHH or when the WP# pin is brought HIGH. (The WP# pin does not apply to the SOP package.) This provides additional security for the core firmware during in-system firmware updates should an unintentional power fluctuation or system reset occur. The MT28F800B3 and MT28F008B3 are available with the boot block starting at the bottom of the address space (“B” suffix) and the top of the address space (“T” suffix).

Selectable Bus Size (MT28F800B3)

The MT28F800B3 allows selection of an 8-bit (1 Meg x 8) or 16-bit (512K x 16) data bus for reading and writing the memory. The BYTE# pin is used to select the bus width. In the x16 configuration, control data is read or written only on the lower eight bits (DQ0–DQ7).

Data written to the memory array utilizes all active data pins for the selected configuration. When the x8 configuration is selected, data is written in byte form; when the x16 configuration is selected, data is written in word form.

Internal State Machine (ISM)

BLOCK ERASE and BYTE/WORD WRITE timing are simplified with an ISM that controls all erase and write algorithms in the memory array. The ISM ensures protection against overerasure and optimizes write margin to each cell.

During WRITE operations, the ISM automatically increments and monitors WRITE attempts, verifies write margin on each memory cell and updates the ISM status register. When BLOCK ERASE is performed, the ISM automatically overwrites the entire addressed block (eliminates overerasure), increments and monitors ERASE attempts, and sets bits in the ISM status register.

ISM Status Register

The ISM status register enables an external processor to monitor the status of the ISM during WRITE and ERASE operations. Two bits of the 8-bit status register are set and cleared entirely by the ISM. These bits indicate whether the ISM is busy with an ERASE or WRITE

task and when an ERASE has been suspended. Additional error information is set in three other bits: VPP status, write status and erase status.

Command Execution Logic (CEL)

The CEL receives and interprets commands to the device. These commands control the operation of the ISM and the read path (i.e., memory array, ID register or status register). Commands may be issued to the CEL while the ISM is active. However, there are restrictions on what commands are allowed in this condition. See the Command Execution section for more detail.

Deep Power-Down Mode

To allow for maximum power conservation, the MT28F800B3 and MT28F008B3 feature a very low current, deep power-down mode. To enter this mode, the RP# pin is taken to VSS ±0.2V. In this mode, the current draw is a maximum of 8µA at 3.3V VCC. Entering deep power-down also clears the status register and sets the ISM to the read array mode.

Memory Architecture

The MT28F800B3 and MT28F008B3 memory array architecture is designed to allow sections to be erased without disturbing the rest of the array. The array is divided into eleven addressable blocks that vary in size and are independently erasable. When blocks rather than the entire array are erased, total device endurance is enhanced, as is system flexibility. Only the

ERASE function is block-oriented. All READ and WRITE operations are done on a random-access basis.

The boot block is protected from unintentional ERASE or WRITE with a hardware protection circuit which requires that a super-voltage be applied to RP# or that the WP# pin be driven HIGH before erasure is commenced. The boot block is intended for the core firmware required for basic system functionality. The remaining ten blocks do not require that either of these two conditions be met before WRITE or ERASE operations.

Boot Block

The hardware-protected boot block provides extra security for the most sensitive portions of the firmware. This 16KB block may only be erased or written when the RP# pin is at the specified boot block unlock voltage (VHH) of 12V or when the WP# pin is HIGH. During a WRITE or ERASE of the boot block, the RP# pin must be held at VHH or the WP# pin held HIGH until the WRITE or ERASE is completed. (The WP# pin does not apply to the SOP package.) The VPP pin must be at VPPH (3.3V or 5V) when the boot block is written to or erased.

The MT28F800B3 and MT28F008B3 are available in two configurations and top or bottom boot block. The top boot block version supports processors of the x86 variety. The bottom boot block version is intended for 680X0 and RISC applications. Figure 3 illustrates the memory address maps associated with these two versions.

Figure 3: Memory Address Maps

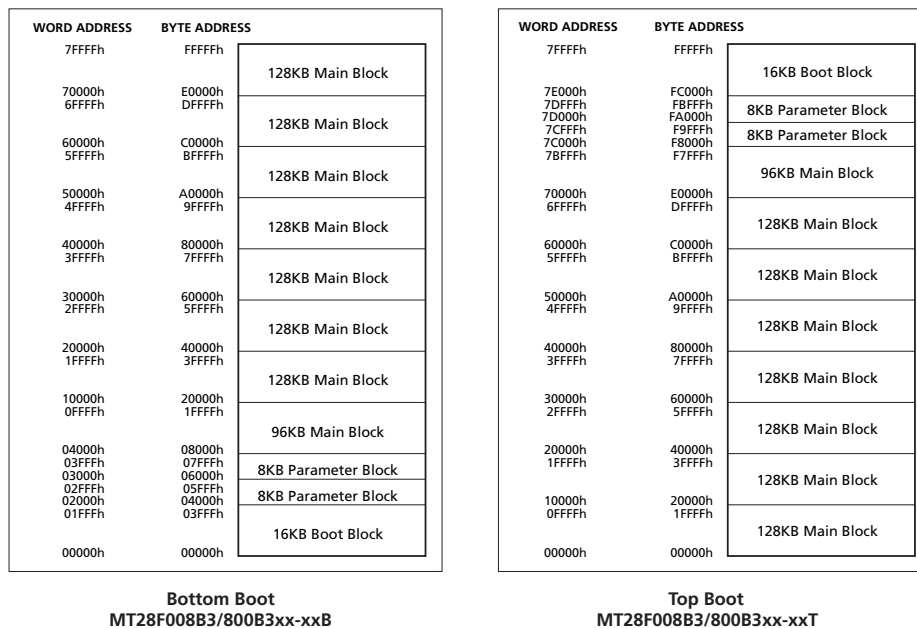

Parameter Blocks

The two 8KB parameter blocks store less sensitive and more frequently changing system parameters and also may store configuration or diagnostic coding. These blocks are enabled for erasure when the VPP pin is at VPPH. No super-voltage unlock or WP# control is required.

Main Memory Blocks

The eight remaining blocks are general-purpose memory blocks and do not require a super-voltage on RP# or WP# control to be erased or written. These blocks are intended for code storage, ROM-resident applications or operating systems that require in-system update capability.

Output (READ) Operations

The MT28F800B3 and MT28F008B3 feature three different types of READs. Depending on the current mode of the device, a READ operation produces data from the memory array, status register or device identification register. In each of these three cases, the WE#, CE# and OE# inputs are controlled in a similar manner. Moving between modes to perform a specific READ is described in the Command Execution section.

Memory Array

To read the memory array, WE# must be HIGH, and OE# and CE# must be LOW. Valid data is output on the DQ pins when these conditions have been met, and a valid address is given. Valid data remains on the DQ pins until the address changes, or until OE# or CE# goes HIGH, whichever occurs first. The DQ pins continue to output new data after each address transition as long as OE# and CE# remain LOW.

The MT28F800B3 features selectable bus widths. When the memory array is accessed as a 512K x 16, BYTE# is HIGH, and data is output on DQ0–DQ15. To access the memory array as a 1 Meg x 8, BYTE# must be LOW, DQ8–DQ14 must be High-Z, and all data must be output on DQ0–DQ7. The DQ15/(A-1) pin becomes the lowest order address input so that 1,048,576 locations can be read.

After power-up or RESET, the device is automatically in the array read mode. All commands and their operations are covered in the Command Set and Command Execution sections.

Status Register

Performing a READ of the status register requires the same input sequencing as a READ of the array except that the address inputs are “Don’t Care.” The status register contents are always output on DQ0–DQ7, regardless of the condition of BYTE# on the MT28F800B3. DQ8–DQ15 are LOW when BYTE# is HIGH, and DQ8–DQ14 are High-Z when BYTE# is LOW. Data from the status register is latched on the falling edge of OE# or CE#, whichever occurs last. If the contents of the status register change during a READ of the status register, either OE# or CE# may be toggled while the other is held LOW to update the output.

Following a WRITE or ERASE, the device automatically enters the status register read mode. In addition, a READ during a WRITE or ERASE produces the status register contents on DQ0–DQ7. When the device is in the erase suspend mode, a READ operation produces the status register contents until another command is issued. In certain other modes, READ STATUS REGISTER may be given to return to the status register read mode. All commands and their operations are described in the Command Set and Command Execution sections.

Identification Register

A READ of the two 8-bit device identification registers requires the same input sequencing as a READ of the array. WE# must be HIGH, and OE# and CE# must be LOW. However, ID register data is output only on DQ0–DQ7, regardless of the condition of BYTE# on the MT28F800B3. A0 is used to decode between the two bytes of the device ID register; all other address inputs are “Don’t Care.” When A0 is LOW, the manufacturer compatibility ID is output, and when A0 is HIGH, the device ID is output. DQ8–DQ15 are High-Z when BYTE# is LOW. When BYTE# is HIGH, DQ8–DQ15 are 00h when the manufacturer compatibility ID is read and 88h when the device ID is read.

To get to the identification register read mode, READ IDENTIFICATION may be issued while the device is in certain other modes. In addition, the identification register read mode can be reached by applying a super-voltage (VID) to the A9 pin. Using this method, the ID register can be read while the device is in any mode. When A9 is returned to VIL or VIH, the device returns to the previous mode.

Input Operations

The DQ pins are used either to input data to the array or to input a command to the CEL. A command input issues an 8-bit command to the CEL to control the mode of operation of the device. A WRITE is used to input data to the memory array. The following section describes both types of inputs. More information describing how to use the two types of inputs to write or erase the device is provided in the Command Execution section.

Commands

To perform a command input, OE# must be HIGH, and CE# and WE# must be LOW. Addresses are “Don’t Care” but must be held stable, except during an ERASE CONFIRM (described in a later section). The 8-bit command is input on DQ0–DQ7, while DQ8–DQ15 are “Don’t Care” on the MT28F800B3. The command is latched on the rising edge of CE# (CE#-controlled) or WE# (WE#-controlled), whichever occurs first. The condition of BYTE# on the MT28F800B3 has no effect on a command input.

Memory Array

A WRITE to the memory array sets the desired bits to logic 0s but cannot change a given bit to a logic 1 from a logic 0. Setting any bits to a logic 1 requires that the entire block be erased. To perform a WRITE, OE#

must be HIGH, CE# and WE# must be LOW, and VPP must be set to VPPH1 or VPPH2. Writing to the boot block also requires that the RP# pin be at VHH or WP# be HIGH. A0–A18 (A19) provide the address to be written, while the data to be written to the array is input on the DQ pins. The data and addresses are latched on the rising edge of CE# (CE#-controlled) or WE# (WE#-controlled), whichever occurs first. A WRITE must be preceded by a WRITE SETUP command. Details on how to input data to the array are described in the Write Sequence section.

Selectable bus sizing applies to WRITES as it does to READs on the MT28F800B3. When BYTE# is LOW (byte mode), data is input on DQ0–DQ7, DQ8–DQ14 are High-Z, and DQ15 becomes the lowest order address input. When BYTE# is HIGH (word mode), data is input on DQ0–DQ15.

Command Set

To simplify writing of the memory blocks, the MT28F800B3 and MT28F008B3 incorporate an ISM that controls all internal algorithms for writing and erasing the floating gate memory cells. An 8-bit command set is used to control the device. Details on how to sequence commands are provided in the Command Execution section. Table 4 lists the valid commands.

Table 4: Command Set

COMMAND	HEX CODE	DESCRIPTION
RESERVED	00h	This command and all unlisted commands are invalid and should not be called. These commands are reserved to allow for future feature enhancements.
READ ARRAY	FFh	Must be issued after any other command cycle before the array can be read. It is not necessary to issue this command after power-up or RESET.
IDENTIFY DEVICE	90h	Allows the device and manufacturer compatibility ID to be read. A0 is used to decode between the manufacturer compatibility ID (A0 = LOW) and device ID (A0 = HIGH).
READ STATUS REGISTER	70h	Allows the status register to be read. Please refer to Table 5 for more information on the status register bits.
CLEAR STATUS REGISTER	50h	Clears status register bits 3-5, which cannot be cleared by the ISM.
ERASE SETUP	20h	The first command given in the two-cycle ERASE sequence. The ERASE is not completed unless followed by ERASE CONFIRM.
ERASE CONFIRM/RESUME	D0h	The second command given in the two-cycle ERASE sequence. Must follow an ERASE SETUP command to be valid. Also used during an ERASE SUSPEND to resume the ERASE.
WRITE SETUP	40h or 10h	The first command given in the two-cycle WRITE sequence. The write data and address are given in the following cycle to complete the WRITE.
ERASE SUSPEND	B0h	Requests a halt of the ERASE and puts the device into the erase suspend mode. When the device is in this mode, only READ STATUS REGISTER, READ ARRAY and ERASE RESUME commands may be executed.

ISM Status Register

The 8-bit ISM status register (see Table 5) is polled to check for WRITE or ERASE completion or any related errors. During or following a WRITE, ERASE or ERASE SUSPEND, a READ operation outputs the status register contents on DQ0–DQ7 without prior command. While the status register contents are read, the outputs are not be updated if there is a change in the ISM status unless OE# or CE# is toggled. If the device is not in the write, erase, erase suspend or status register read mode, READ STATUS REGISTER (70h) can be issued to view the status register contents.

All of the defined bits are set by the ISM, but only the ISM and erase suspend status bits are reset by the ISM. The erase, write and VPP status bits must be cleared using CLEAR STATUS REGISTER. If the VPP status bit (SR3) is set, the CEL does not allow further WRITE or ERASE operations until the status register is cleared. This enables the user to choose when to poll and clear the status register. For example, the host system may perform multiple BYTE WRITE operations before checking the status register instead of checking after each individual WRITE. Asserting the RP# signal or powering down the device also clears the status register.

Table 5: Status Register Bit Definitions

ISMS	ESS	ES	WS	VPPS	R
7	6	5	4	3	2–0

STATUS BIT #	STATUS REGISTER BIT	DESCRIPTION
SR7	ISM STATUS (ISMS) 1 = Ready 0 = Busy	The ISMS bit displays the active status of the state machine during WRITE or BLOCK ERASE operations. The controlling logic polls this bit to determine when the erase and write status bits are valid.
SR6	ERASE SUSPEND STATUS (ESS) 1 = ERASE suspended 0 = ERASE in progress/completed	Issuing an ERASE SUSPEND places the ISM in the suspend mode and sets this and the ISMS bit to "1." The ESS bit remains "1" until an ERASE RESUME is issued.
SR5	ERASE STATUS (ES) 1 = BLOCK ERASE error 0 = Successful BLOCK ERASE	ES is set to "1" after the maximum number of ERASE cycles is executed by the ISM without a successful verify. ES is only cleared by a CLEAR STATUS REGISTER command or after a RESET.
SR4	WRITE STATUS (WS) 1 = WORD/BYTE WRITE error 0 = Successful WORD/BYTE WRITE	WS is set to "1" after the maximum number of WRITE cycles is executed by the ISM without a successful verify. WS is only cleared by a CLEAR STATUS REGISTER command or after a RESET.
SR3	VPP STATUS (VPPS) 1 = No VPP voltage detected 0 = VPP present	VPPS detects the presence of a VPP voltage. It does not monitor VPP continuously, nor does it indicate a valid VPP voltage. The VPP pin is sampled for 3.3V or 5V after WRITE or ERASE CONFIRM is given. VPPS must be cleared by CLEAR STATUS REGISTER or by a RESET.
SR0–2	RESERVED	Reserved for future use.

Command Execution

Commands are issued to bring the device into different operational modes. Each mode allows specific operations to be performed. Several modes require a sequence of commands to be written before they are reached. The following section describes the properties of each mode, and Table 6 lists all command sequences required to perform the desired operation.

Read Array

The array read mode is the initial state of the device upon power-up and after a RESET. If the device is in any other mode, READ ARRAY (FFh) must be given to return to the array read mode. Unlike the WRITE SETUP command (40h), READ ARRAY does not need to be given before each individual READ access.

IDENTIFY DEVICE

IDENTIFY DEVICE (90h) may be written to the CEL to enter the identify device mode. While the device is in this mode, any READ produces the device identification when A0 is HIGH and the manufacturer compatibility identification when A0 is LOW. The device remains in this mode until another command is given.

Write Sequence

Two consecutive cycles are needed to input data to the array. WRITE SETUP (40h or 10h) is given in the first cycle. The next cycle is the WRITE, during which

the write address and data are issued and VPP is brought to VPPH. Writing to the boot block also requires that the RP# pin be brought to VHH or the WP# pin be brought HIGH at the same time VPP is brought to VPPH. The ISM now begins to write the word or byte. VPP must be held at VPPH until the WRITE is completed (SR7 = 1).

While the ISM executes the WRITE, the ISM status bit (SR7) is at 0, and the device does not respond to any commands. Any READ operation produces the status register contents on DQ0–DQ7. When the ISM status bit (SR7) is set to a logic 1, the WRITE has been completed, and the device goes into the status register read mode until another command is given.

After the ISM has initiated the WRITE, it cannot be aborted except by a RESET or by powering down the part. Doing either during a WRITE corrupts the data being written. If only the WRITE SETUP command has been given, the WRITE may be nullified by performing a null WRITE. To execute a null WRITE, FFh must be written when BYTE# is LOW, or FFFFh must be written when BYTE# is HIGH. When the ISM status bit (SR7) has been set, the device is in the status register read mode until another command is issued.

Table 6: Command Sequences

COMMANDS	BUS CYCLES REQ'D	OPERATION ADDRESS	FIRST CYCLE	DATA	OPERATION ADDRESS	SECOND CYCLE	DATA	NOTES
READ ARRAY	1	WRITE	X	FFh				1
IDENTIFY DEVICE	3	WRITE	X	90h	READ	IA	ID	2, 3
READ STATUS REGISTER	2	WRITE	X	70h	READ	X	SRD	4
CLEAR STATUS REGISTER	1	WRITE	X	50h				
ERASE SETUP/CONFIRM	2	WRITE	X	20h	WRITE	BA	D0h	5, 6
ERASE SUSPEND/RESUME	2	WRITE	X	80h	WRITE	X	D0h	
WRITE SETUP/WRITE	2	WRITE	X	40h	WRITE	WA	WD	6, 7
ALTERNATE WORD/BYTE WRITE	2	WRITE	X	10h	WRITE	WA	WD	6, 7

NOTE:

1. Must follow WRITE or ERASE CONFIRM commands to the CEL in order to enable Flash array READ cycles.
2. IA = Identify Address: 00h for manufacturer compatibility ID; 01h for device ID.
3. ID = Identify Data.
4. SRD = Status Register Data.
5. BA = Block Address (A12–A19).
6. Addresses are “Don’t Care” in first cycle but must be held stable.
7. WA = Address to be written; WD = Data to be written to WA.

ERASE Sequence

Executing an ERASE sequence sets all bits within a block to logic 1. The command sequence necessary to execute an ERASE is similar to that of a WRITE. To provide added security against accidental block erasure, two consecutive command cycles are required to initiate an ERASE of a block. In the first cycle, addresses are “Don’t Care,” and ERASE SETUP (20h) is given. In the second cycle, VPP must be brought to VPPH, an address within the block to be erased must be issued, and ERASE CONFIRM (D0h) must be given. If a command other than ERASE CONFIRM is given, the write and erase status bits (SR4 and SR5) are set, and the device is in the status register read mode.

After the ERASE CONFIRM (D0h) is issued, the ISM starts the ERASE of the addressed block. Any READ operation outputs the status register contents on DQ0–DQ7. VPP must be held at VPPH until the ERASE is completed (SR7 = 1). When the ERASE is completed, the device is in the status register read mode until another command is issued. Erasing the boot block also requires that either the RP# pin be set to VHH or the WP# pin be held HIGH at the same time VPP is set to VPPH.

ERASE Suspension

The only command that may be issued while an ERASE is in progress is ERASE SUSPEND. This command enables other commands to be executed while pausing the ERASE in progress. When the device has reached the erase suspend mode, the erase suspend status bit (SR6) and ISM status bit (SR7) are set. The device may now be given a READ ARRAY, ERASE RESUME or READ STATUS REGISTER command. After READ ARRAY has been issued, any location not within the block being erased may be read. If ERASE RESUME is issued before SR6 has been set, the device immediately proceeds with the ERASE in progress.

Error Handling

After the ISM status bit (SR7) has been set, the VPP (SR3), write (SR4) and erase (SR5) status bits may be checked. If one or a combination of these three bits has been set, an error has occurred. The ISM cannot reset these three bits. To clear these bits, CLEAR STATUS REGISTER (50h) must be given. If the VPP status bit (SR3) is set, further WRITE or ERASE operations cannot resume until the status register is cleared. Table 7 lists the combination of errors.

Table 7: Status Register Error Code Description¹

STATUS BITS			ERROR DESCRIPTION
SR5	SR4	SR3	
0	0	0	No errors
0	0	1	VPP voltage error
0	1	0	WRITE error
0	1	1	WRITE error, VPP voltage not valid at time of WRITE
1	0	0	ERASE error
1	0	1	ERASE error, VPP voltage not valid at time of ERASE CONFIRM
1	1	0	Command sequencing error or WRITE/ERASE error
1	1	1	Command sequencing error, VPP voltage error, with WRITE and ERASE errors

NOTE:

1. SR3–SR5 must be cleared using CLEAR STATUS REGISTER.

WRITE/ERASE Cycle Endurance

The MT28F800B3 and MT28F008B3 are designed and fabricated to meet advanced firmware storage requirements. To ensure this level of reliability, V_{PP} must be at $3.3V \pm 0.3V$ or $5V \pm 10\%$ during WRITE or ERASE cycles. Due to process technology advances, 5V V_{PP} is optimal for application and production programming.

Power Usage

The MT28F800B3 and MT28F008B3 offer several power-saving features that may be utilized in the array read mode to conserve power. Deep power-down mode is enabled by bringing RP# LOW. Current draw (I_{CC}) in this mode is a maximum of $8\mu A$ at 3.3V VCC. When CE# is HIGH, the device enters standby mode. In this mode, maximum I_{CC} current is $100\mu A$ at 3.3V VCC. If CE# is brought HIGH during a WRITE or ERASE, the ISM continues to operate, and the device consumes the respective active power until the WRITE or ERASE is completed.

Power-Up

The likelihood of unwanted WRITE or ERASE operations is minimized because two consecutive cycles are required to execute either operation. However, to reset the ISM and to provide additional protection while VCC is ramping, one of the following conditions must be met:

- RP# must be held LOW until VCC is at valid functional level; or
- CE# or WE# may be held HIGH and RP# must be toggled from VCC-GND-VCC.

After a power-up or RESET, the status register is reset, and the device enters the array read mode.

Figure 4: Power-Up/Reset Timing Diagram

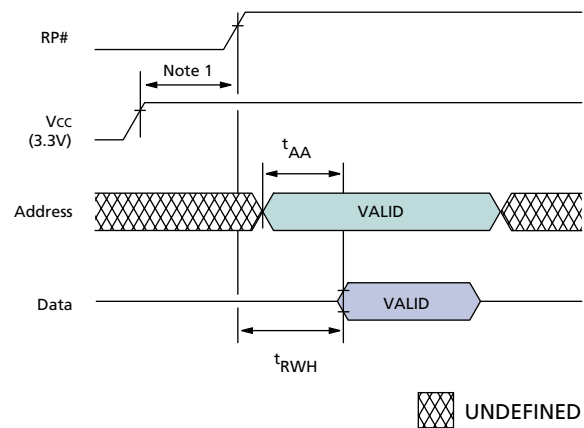

NOTE: 1. Vcc must be within the valid operating range before RP# goes HIGH.

NOTE:

1. Vcc must be within the valid operating range before RP# goes HIGH.

Figure 5: Self-Timed WRITE Sequence (Word or Byte WRITE)¹

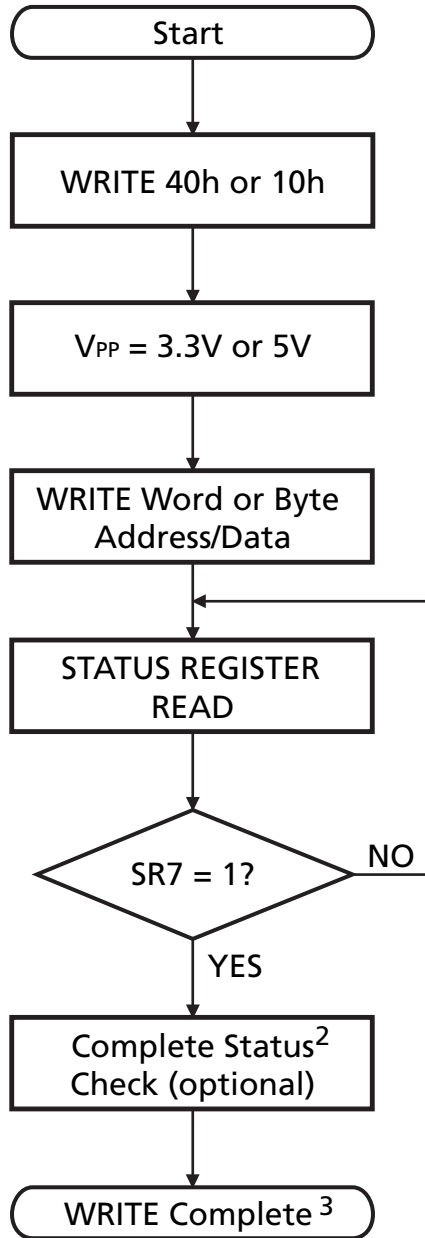
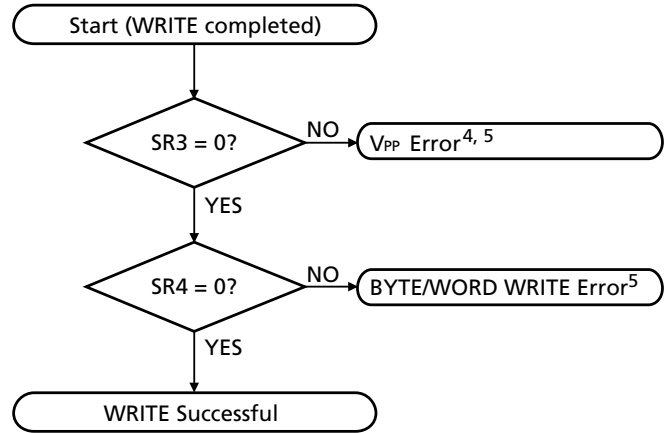

Figure 6: Complete WRITE Status-Check Sequence



NOTE:

1. Sequence may be repeated for additional BYTE or WORD WRITES.
2. Complete status check is not required. However, if SR3 = 1, further WRITES are inhibited until the status register is cleared.
3. Device will be in status register read mode. To return to the array read mode, the FFh command must be issued.
4. If SR3 is set during a WRITE or BLOCK ERASE attempt, CLEAR STATUS REGISTER must be issued before further WRITE or ERASE operations are allowed by the CEL.
5. Status register bits 3-5 must be cleared using CLEAR STATUS REGISTER.

Figure 7: Self-Timed BLOCK ERASE Sequence¹

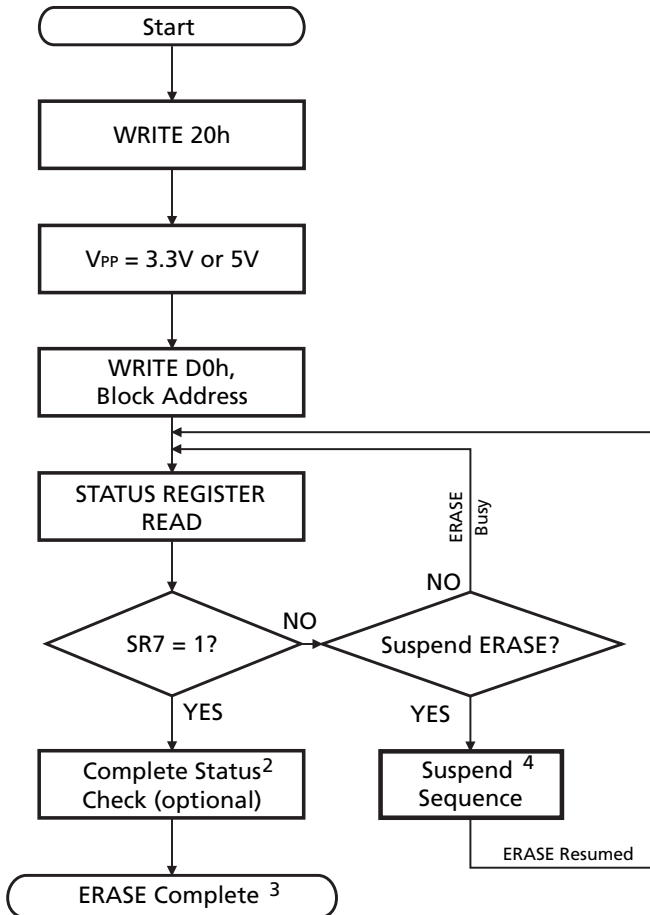
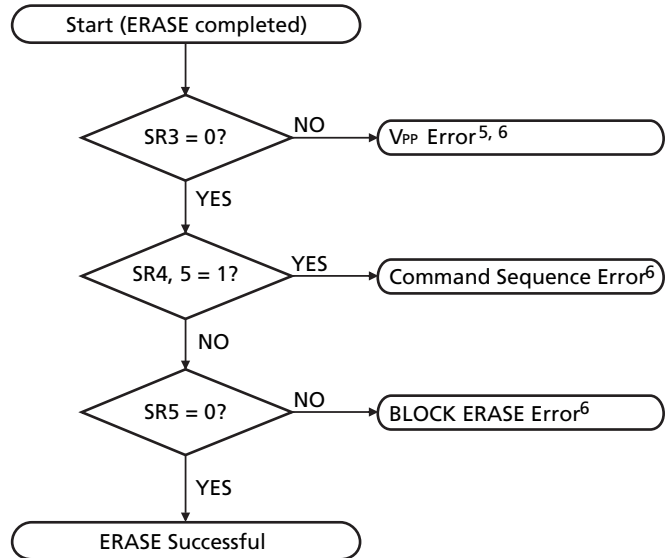

Figure 8: Complete BLOCK ERASE Status-Check Sequence



NOTE:

1. Sequence may be repeated to erase additional blocks.
2. Complete status check is not required. However, if SR3 = 1, further ERASEs are inhibited until the status register is cleared.
3. To return to the array read mode, the FFh command must be issued.
4. Refer to the ERASE SUSPEND flowchart for more information.
5. If SR3 is set during a WRITE or BLOCK ERASE attempt, CLEAR STATUS REGISTER must be issued before further WRITE or ERASE operations are allowed by the CEL.
6. Status register bits 3-5 must be cleared using CLEAR STATUS REGISTER.

Figure 9: ERASE SUSPEND/RESUME SEQUENCE

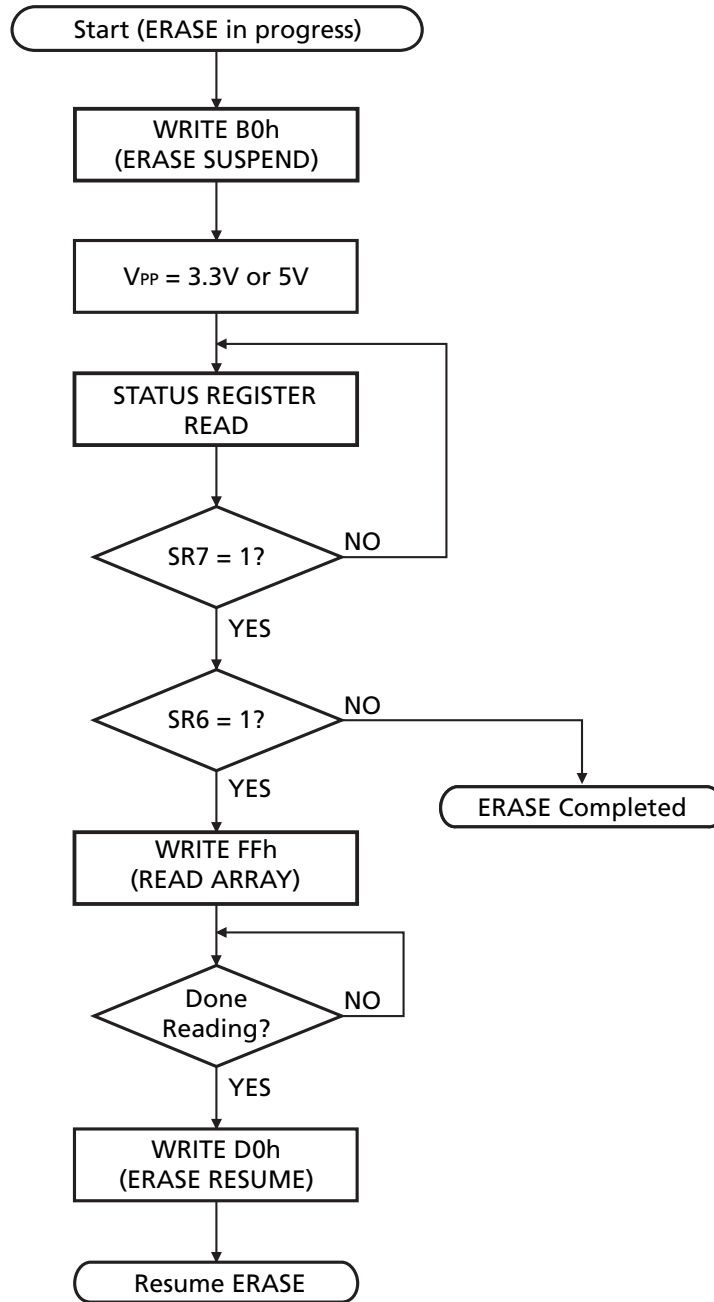

Absolute Maximum Ratings*

Voltage on VCC Supply	
Relative to VSS	-0.5V to +4V**
Input Voltage Relative to VSS.	-0.5V to +4V**
VPP Voltage Relative to VSS.	-0.5V to +5.5V†
RP# or A9 Pin Voltage	
Relative to VSS	-0.5V to +12.6V††
Temperature Under Bias	-10°C to +80°C
Storage Temperature (plastic).	-55°C to +125°C
Power Dissipation	1W

*Stresses greater than those listed under “Absolute Maximum Ratings” may cause permanent damage to the device. This is a stress rating only, and functional operation of the device at these or any other conditions above those indicated in the operational sections of this specification is not implied. Exposure to absolute maximum rating conditions for extended periods may affect reliability.

**VCC, input and I/O pins may transition to -2V for <20ns and VCC + 2V for <20ns.

† Voltage may pulse to -2V for <20ns and 7V for <20ns.

†† Voltage may pulse to -2V for <20ns and 14V for <20ns.

Table 8: Electrical Characteristics and Recommended DC READ Operating Conditions

 Commercial Temperature (0°C ≤ T_A ≤ +70°C) and Extended Temperature (-40°C ≤ T_A ≤ +85°C)

PARAMETER/CONDITION	SYMBOL	MIN	MAX	UNITS	NOTES
3.3V Supply Voltage	VCC	3	3.6	V	1
Input High (Logic 1) Voltage, all inputs	V _{IH}	2.4	V _{CC} + 0.5	V	1
Input Low (Logic 0) Voltage, all inputs	V _{IL}	-0.5	0.8	V	1
Device Identification Voltage, A9	V _{ID}	10	12.6	V	1
VPP Supply Voltage	VPP	-0.5	5.5	V	1

Table 9: DC Operating Characteristics

 Commercial Temperature (0°C ≤ T_A ≤ +70°C) and Extended Temperature (-40°C ≤ T_A ≤ +85°C)

PARAMETER/CONDITION	SYMBOL	MIN	MAX	UNITS	NOTES
OUTPUT VOLTAGE LEVELS	V _{OH}	V _{CC} - 0.2	-	V	1
Output High Voltage (I _{OH} = -100μA)	V _{OL}	-	0.45	V	
Output Low Voltage (I _{OL} = 2mA)					
INPUT LEAKAGE CURRENT	I _L	-1	1	μA	
Any input (0V ≤ V _{IN} ≤ V _{CC}); All other pins not under test = 0V					
INPUT LEAKAGE CURRENT: A9 INPUT (10V ≤ A9 ≤ 12V = V _{ID})	I _{ID}	-	500	μA	
INPUT LEAKAGE CURRENT: RP# INPUT (10V ≤ RP# ≤ 12V = V _{IHH})	I _{IHH}	-	500	μA	
OUTPUT LEAKAGE CURRENT (DOUT is disabled; 0V ≤ V _{OUT} ≤ V _{CC})	I _{OZ}	-10	10	μA	

NOTE:

1. All voltages referenced to V_{SS}.

Table 10: Capacitance
 $(T_A = 25^\circ\text{C}; f = 1 \text{ MHz})$

PARAMETER/CONDITION	SYMBOL	MAX	UNITS	NOTES
Input Capacitance	C _i	9	pF	
Output Capacitance	C _o	12	pF	

Table 11: READ and STANDBY Current Drain¹

 Commercial Temperature ($0^\circ\text{C} \leq T_A \leq +70^\circ\text{C}$) and Extended Temperature ($-40^\circ\text{C} \leq T_A \leq +85^\circ\text{C}$)

PARAMETER/CONDITION	SYMBOL	MAX	UNITS	NOTES
READ CURRENT: WORD-WIDE (CE# $\leq 0.2\text{V}$; OE# $V_{cc} - 0.2\text{V}$; $f = 5 \text{ MHz}$; Other inputs $\leq 0.2\text{V}$ or $V_{cc} - 0.2\text{V}$; RP# $V_{cc} - 0.2\text{V}$)	I _{cc1}	15	mA	2, 3
READ CURRENT: BYTE-WIDE (CE# $\leq 0.2\text{V}$; OE# $V_{cc} - 0.2\text{V}$; $f = 5 \text{ MHz}$; Other inputs $\leq 0.2\text{V}$ or $V_{cc} - 0.2\text{V}$; RP# = $V_{cc} - 0.2\text{V}$)	I _{cc2}	15	mA	2, 3
STANDBY CURRENT: TTL INPUT LEVELS V _{cc} power supply standby current (CE# = RP# = V _{IH} ; Other inputs = V _{IL} or V _{IH})	I _{cc3}	2	mA	
STANDBY CURRENT: CMOS INPUT LEVELS V _{cc} power supply standby current (CE# = RP# = $V_{cc} - 0.2\text{V}$)	I _{cc4}	100	μA	
DEEP POWER-DOWN CURRENT: V _{cc} SUPPLY (RP# = $V_{ss} \pm 0.2\text{V}$)	I _{cc6}	20	μA	
STANDBY OR READ CURRENT: V _{PP} SUPPLY (V _{PP} $\leq 5.5\text{V}$)	I _{PP1}	± 15	μA	
DEEP POWER-DOWN CURRENT: V _{PP} SUPPLY (RP# = $V_{ss} \pm 0.2\text{V}$)	I _{PP2}	5	μA	

NOTE:

1. V_{cc} = MAX V_{cc} during I_{cc} tests.
2. I_{cc} is dependent on cycle rates.
3. I_{cc} is dependent on output loading. Specified values are obtained with the outputs open.

Table 12: READ Timing Parameters Electrical Characteristics and Recommended AC Operating Conditions¹

 Commercial Temperature ($0^{\circ}\text{C} \leq T_A \leq +70^{\circ}\text{C}$) and Extended Temperature ($-40^{\circ}\text{C} \leq T_A \leq +85^{\circ}\text{C}$); $V_{cc} = +3.3\text{V} \pm 0.3\text{V}$

AC CHARACTERISTICS		-9/-9 ET		UNITS	NOTES
PARAMETER	SYMBOL	MIN	MAX		
READ cycle time	t_{RC}	90		ns	
Access time from CE#	t_{ACE}		90	ns	2
Access time from OE#	t_{AOE}		40	ns	2
Access time from address	t_{AA}		90	ns	
RP# HIGH to output valid delay	t_{RWH}		1,000	ns	
OE# or CE# HIGH to output in High-Z	t_{OD}		25	ns	
Output hold time from OE#, CE# or address change	t_{OH}	0		ns	
RP# LOW pulse width	t_{RP}	150		ns	

NOTE:

1. $V_{cc} = \text{MAX } V_{cc}$ during Icc tests. Icc is dependent on cycle rates.
2. Icc is dependent on output loading. Specified values are obtained with the outputs open.

AC Test Conditions

Input pulse levels. 0V to 3V
 Input rise and fall times. <10ns
 Input timing reference level 1.5V
 Output timing reference level. 1.5V
 Output load. 1TTL gate and $CL = 50\text{pF}$

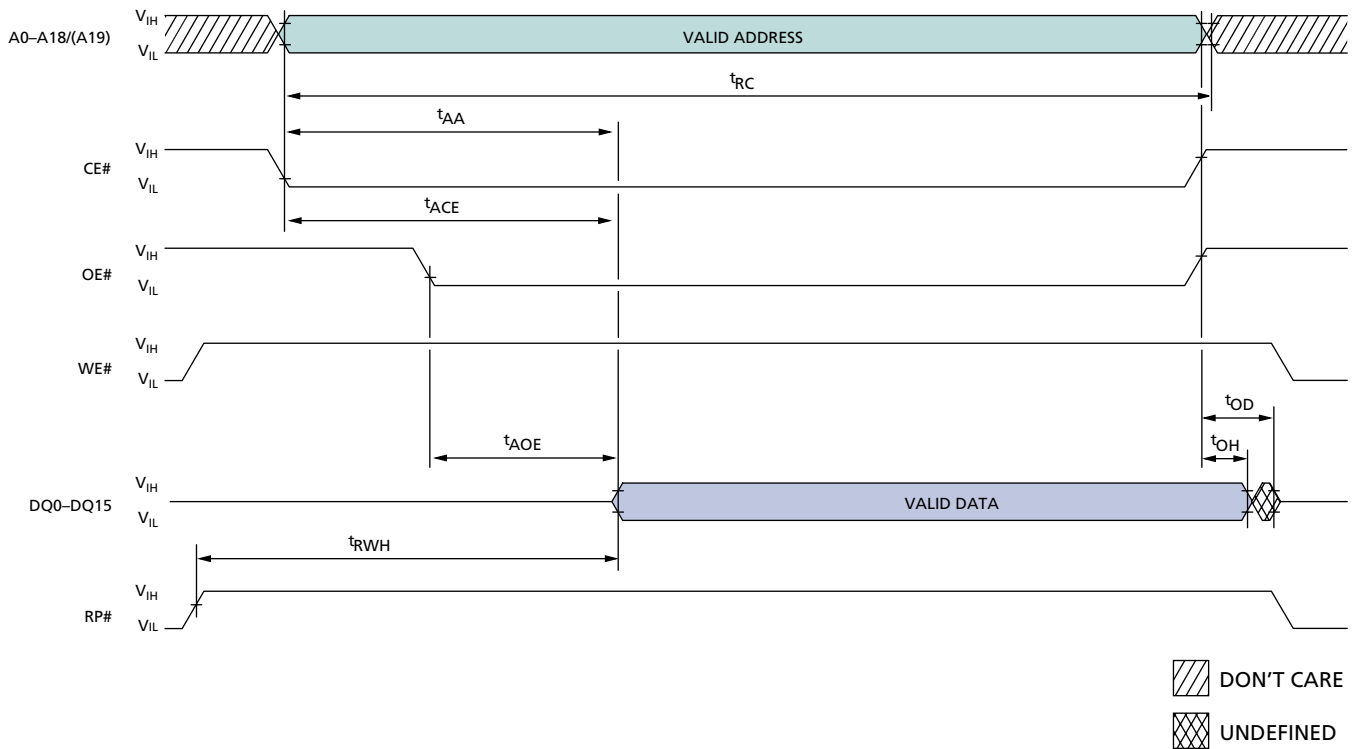
Figure 10: Word-Wide READ Cycle¹

Timing Parameters

 Commercial Temperature ($0^{\circ}\text{C} \leq T_A \leq +70^{\circ}\text{C}$)

 Extended Temperature ($-40^{\circ}\text{C} \leq T_A \leq +85^{\circ}\text{C}$)

SYMBOL	-9/-9 ET		UNITS
	MIN	MAX	
t_{RC}	90		ns
t_{ACE}		90	ns
t_{AOE}		40	ns
t_{AA}		90	ns

SYMBOL	-9/-9 ET		UNITS
	MIN	MAX	
t_{RWH}		1,000	ns
t_{OD}		25	ns
t_{OH}	0		ns

NOTE:

1. BYTE# = HIGH (MT28F800B3 only).

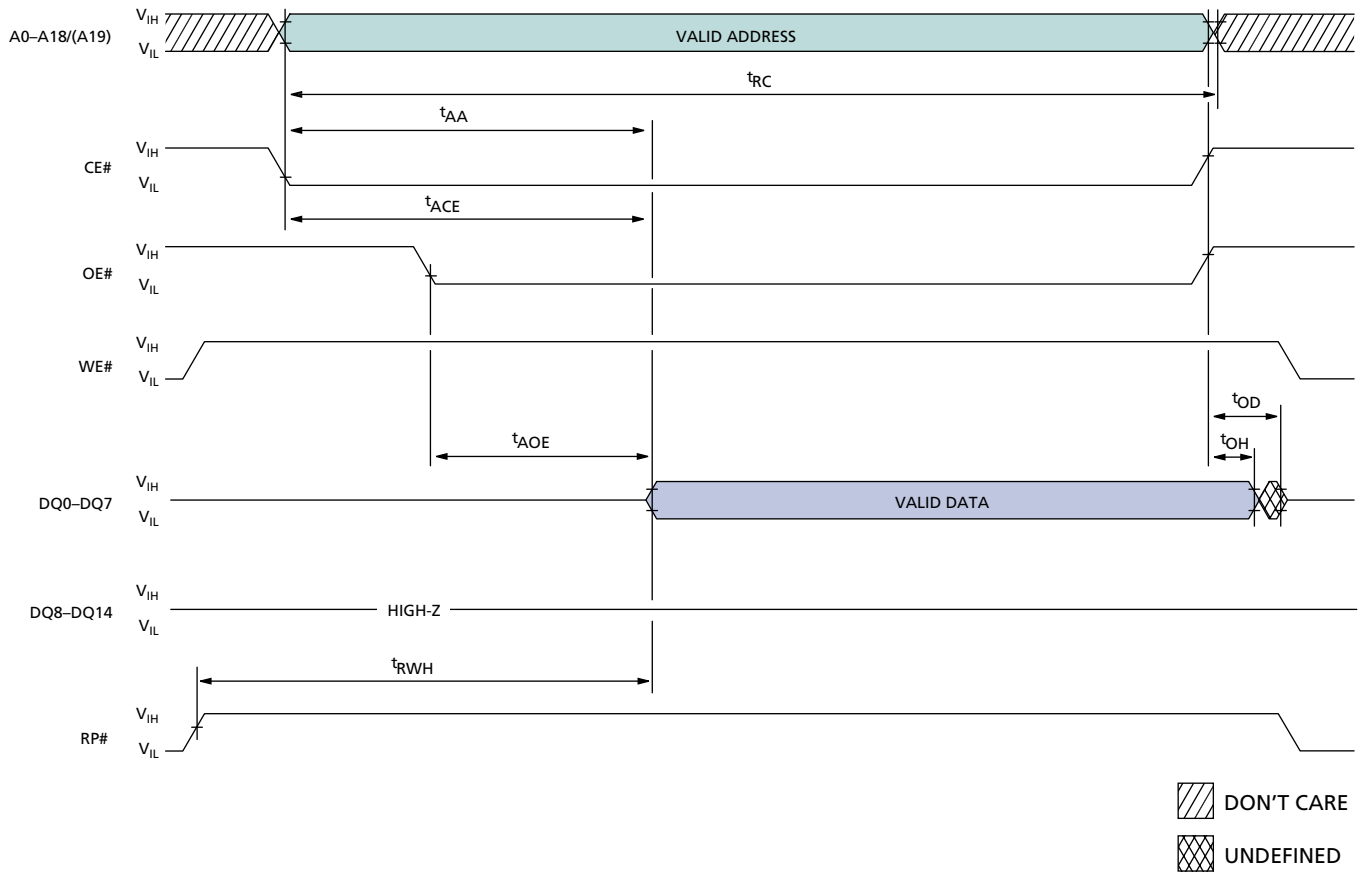
Figure 11: Byte-Wide READ Cycle¹

Timing Parameters

 Commercial Temperature ($0^{\circ}\text{C} \leq T_A \leq +70^{\circ}\text{C}$)

 Extended Temperature ($-40^{\circ}\text{C} \leq T_A \leq +85^{\circ}\text{C}$)

SYMBOL	-9/-9 ET		UNITS
	MIN	MAX	
t_{RC}	90		ns
t_{ACE}		90	ns
t_{AOE}		40	ns
t_{AA}		90	ns

SYMBOL	-9/-9 ET		UNITS
	MIN	MAX	
t_{RWH}		1,000	ns
t_{OD}		25	ns
t_{OH}	0		ns

NOTE:

1. BYTE# = LOW (MT28F800B3 only).

Table 13: Recommended DC WRITE/ERASE Conditions¹

 Commercial Temperature ($0^{\circ}\text{C} \leq T_A \leq +70^{\circ}\text{C}$) and Extended Temperature ($-40^{\circ}\text{C} \leq T_A \leq +85^{\circ}\text{C}$); $V_{CC} = +3.3\text{V} \pm 0.3\text{V}$

PARAMETER/CONDITION	SYMBOL	MIN	MAX	UNITS	NOTES
V _{PP} WRITE/ERASE lockout voltage	V _{PPLK}	–	1.5	V	2
V _{PP} voltage during WRITE/ERASE operation	V _{PPH1}	3.0	3.6	V	3
V _{PP} voltage during WRITE/ERASE operation	V _{PPH2}	4.5	5.5	V	
Boot block unlock voltage	V _{HH}	10	12.6	V	
V _{CC} WRITE/ERASE lockout voltage	V _{LKO}	2	–	V	

Table 14: WRITE/ERASE Current Drain⁴

 Commercial Temperature ($0^{\circ}\text{C} \leq T_A \leq +70^{\circ}\text{C}$) and Extended Temperature ($-40^{\circ}\text{C} \leq T_A \leq +85^{\circ}\text{C}$); $V_{CC} = +3.3\text{V} \pm 0.3\text{V}$

PARAMETER/CONDITION	SYMBOL	3.3V V _{PP}	5V V _{PP}	UNITS	NOTES
		MAX	MAX		
WORD WRITE CURRENT: V _{CC} SUPPLY	I _{CC7}	20	20	mA	5
WORD WRITE CURRENT: V _{PP} SUPPLY	I _{PP3}	20	20	mA	5
BYTE WRITE CURRENT: V _{CC} SUPPLY	I _{CC8}	20	20	mA	6
BYTE WRITE CURRENT: V _{PP} SUPPLY	I _{PP4}	20	20	mA	6
ERASE CURRENT: V _{CC} SUPPLY	I _{CC9}	25	25	mA	
ERASE CURRENT: V _{PP} SUPPLY	I _{PP5}	25	30	mA	
ERASE SUSPEND CURRENT: V _{CC} SUPPLY (ERASE suspended)	I _{CC10}	8	10	mA	7
ERASE SUSPEND CURRENT: V _{PP} SUPPLY (ERASE suspended)	I _{PP6}	200	200	μA	

NOTE:

1. WRITE operations are tested at V_{PP} voltages equal to or less than the previous ERASE.
2. Absolute WRITE/ERASE protection when $V_{PP} \leq V_{PPLK}$.
3. When 3.3V V_{CC} and V_{PP} are used, V_{CC} cannot exceed V_{PP} by more than 500mV during WRITE and ERASE operations.
4. All currents are in RMS unless otherwise noted.
5. Applies to MT28F800B3 only.
6. Applies to MT28F008B3 and MT28F800B3 with BYTE# = LOW.
7. Parameter is specified when device is not accessed. Actual current draw will be I_{CC10} plus read current if a READ is executed while the device is in erase suspend mode.

Table 15: Speed-Dependent WRITE/ERASE AC Timing Characteristics and Recommended AC Operating Conditions: WE# (CE#)-Controlled WRITES

 Commercial Temperature ($0^{\circ}\text{C} \leq T_A \leq +70^{\circ}\text{C}$) and Extended Temperature ($-40^{\circ}\text{C} \leq T_A \leq +85^{\circ}\text{C}$); $V_{CC} = +3.3\text{V} \pm 0.3\text{V}$

AC CHARACTERISTICS	PARAMETER	SYMBOL	-9/-9 ET		UNITS	NOTES
			MIN	MAX		
WRITE cycle time		t_{WC}	90		ns	
WE# (CE#) HIGH pulse width		t_{WPH} (t_{CPH})	20		ns	
WE# (CE#) pulse width		t_{WP} (t_{CP})	50		ns	
Address setup time to WE# (CE#) HIGH		t_{AS}	50		ns	
Address hold time from WE# (CE#) HIGH		t_{AH}	0		ns	
Data setup time to WE# (CE#) HIGH		t_{DS}	50		ns	
Data hold time from WE# (CE#) HIGH		t_{DH}	0		ns	
CE# (WE#) setup time to WE# (CE#) LOW		t_{CS} (t_{WS})	0		ns	
CE# (WE#) hold time from WE# (CE#) HIGH		t_{CH} (t_{WH})	0		ns	
VPP setup time to WE# (CE#) HIGH		t_{VPS1}	200		ns	1
VPP setup time to WE# (CE#) HIGH		t_{VPS2}	100		ns	2
RP# HIGH to WE# (CE#) LOW delay		t_{RS}	1,000		ns	
RP# at VHH or WP# HIGH setup time to WE# (CE#) HIGH		t_{RHS}	100		ns	3
WRITE duration (WORD or BYTE WRITE)		t_{WED1}	2		μs	5
Boot BLOCK ERASE duration		t_{WED2}	100		ms	5
Parameter BLOCK ERASE duration		t_{WED3}	100		ms	5
Main BLOCK ERASE duration		t_{WED4}	500		ms	5
WE# (CE#) HIGH to busy status (SR7 = 0)		t_{WB}	200		ns	4
VPP hold time from status data valid		t_{VPH}	0		ns	5
RP# at VHH or WP# HIGH hold time from status data valid		t_{RHH}	0		ns	3
Boot block relock delay time		t_{REL}		100	ns	6

Table 16: Word/Byte WRITE and ERASE Duration Characteristics

PARAMETER	3.3V VPP		5V VPP		UNITS	NOTES
	TYP	MAX	TYP	MAX		
Boot/parameter BLOCK ERASE time	0.5	7	0.4	7	s	7
Main BLOCK ERASE time	2.8	14	1.5	14	s	7
Main BLOCK WRITE time (byte mode)	1.5	–	1	–	s	7, 8, 9
Main BLOCK WRITE time (word mode)	1.5	–	1	–	s	7, 8, 9

NOTE:

1. Measured with $V_{PP} = V_{PPH1} = 3.3\text{V}$.
2. Measured with $V_{PP} = V_{PPH2} = 5\text{V}$.
3. RP# should be held at VHH or WP# held HIGH until boot block WRITE or ERASE is complete.
4. Polling status register before t_{WB} is met may falsely indicate WRITE or ERASE completion.
5. WRITE/ERASE times are measured to valid status register data (SR7 = 1).
6. t_{REL} is required to relock boot block after WRITE or ERASE to boot block.
7. Typical values measured at $T_A = +25^{\circ}\text{C}$.
8. Assumes no system overhead.
9. Typical WRITE times use checkerboard data pattern.

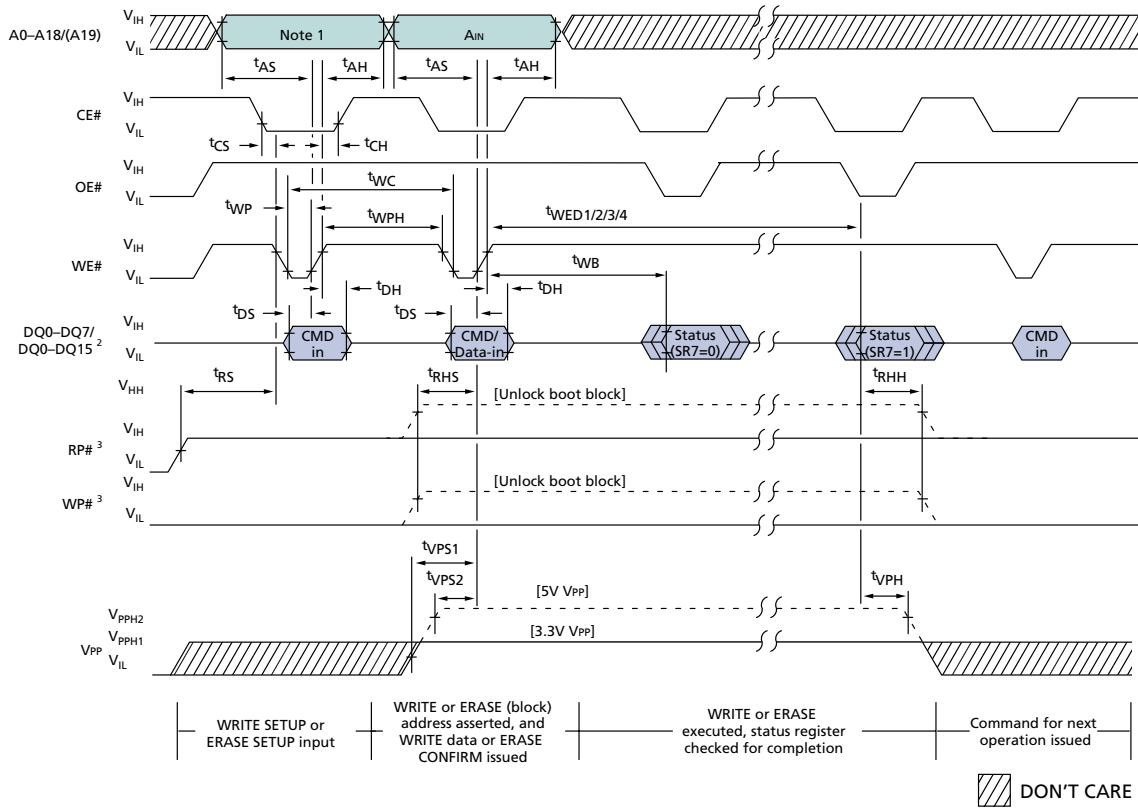
**Figure 12: WRITE/ERASE Cycle
WE#-Controlled WRITE/ERASE**

Timing Parameters

Commercial Temperature ($0^{\circ}\text{C} \leq T_A \leq +70^{\circ}\text{C}$)

Extended Temperature ($-40^{\circ}\text{C} \leq T_A \leq +85^{\circ}\text{C}$)

SYMBOL	-9/-9 ET		UNITS
	MIN	MAX	
t_{WC}	90		ns
t_{WPH}	20		ns
t_{WP}	50		ns
t_{AS}	50		ns
t_{AH}	0		ns
t_{DS}	50		ns
t_{DH}	0		ns
t_{CS}	0		ns
t_{CH}	0		ns
t_{VPS1}	200		ns

SYMBOL	-9/-9 ET		UNITS
	MIN	MAX	
t_{VPS2}	100		ns
t_{RS}	1,000		ns
t_{RHS}	100		ns
t_{WED1}	2		μs
t_{WED2}	100		ms
t_{WED3}	100		ms
t_{WED4}	500		ms
t_{WB}	200		ns
t_{VPH}	0		ns
t_{RHH}	0		ns

NOTE:

1. Address inputs are "Don't Care" but must be held stable.
2. If BYTE# is LOW, data and command are 8-bit. If BYTE# is HIGH, data is 16-bit and command is 8-bit.
3. Either RP# at V_{HH} or WP# HIGH unlocks the boot block.

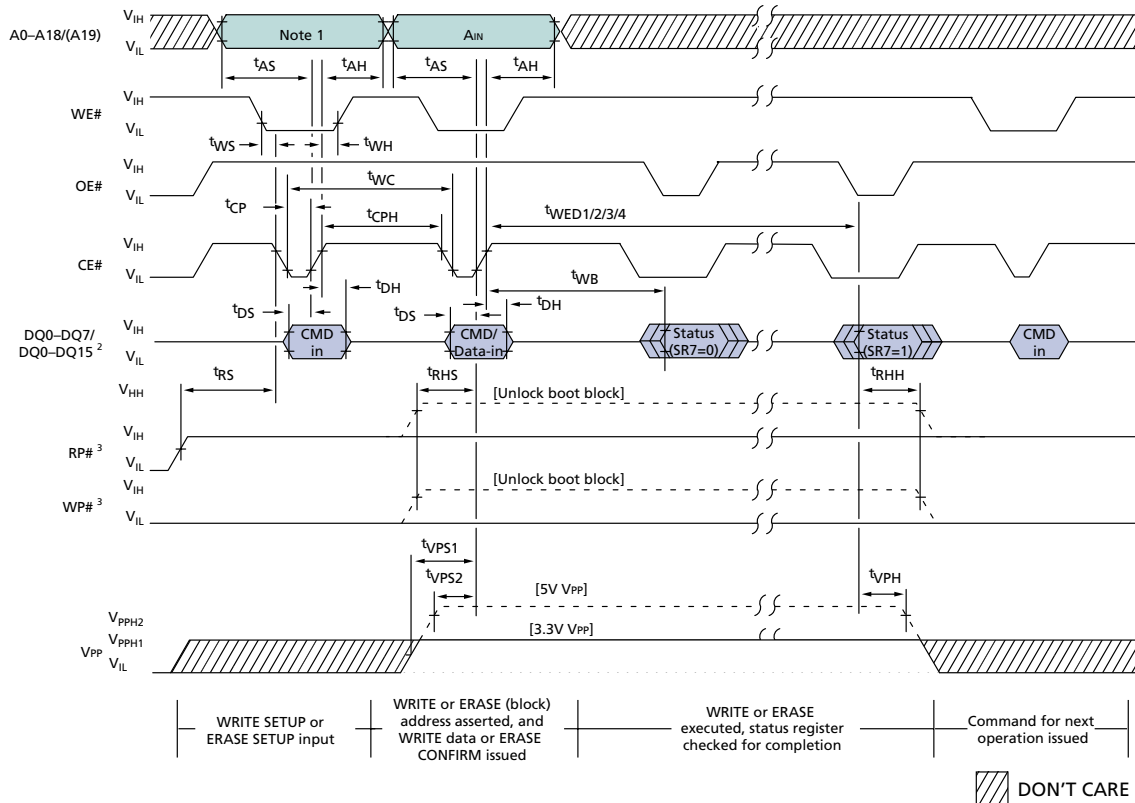
**Figure 13: WRITE/ERASE Cycle
CE#-Controlled WRITE/ERASE**

Timing Parameters

Commercial Temperature ($0^{\circ}\text{C} \leq T_A \leq +70^{\circ}\text{C}$)

Extended Temperature ($-40^{\circ}\text{C} \leq T_A \leq +85^{\circ}\text{C}$)

SYMBOL	-9/-9 ET		UNITS
	MIN	MAX	
t_{WC}	90		ns
t_{CPH}	20		ns
t_{CP}	50		ns
t_{AS}	50		ns
t_{AH}	0		ns
t_{DS}	50		ns
t_{DH}	0		ns
t_{WS}	0		ns
t_{WH}	0		ns
t_{VPS1}	200		ns

SYMBOL	-9/-9 ET		UNITS
	MIN	MAX	
t_{VPS2}	100		ns
t_{RS}	1,000		ns
t_{RHS}	100		ns
t_{WED1}	2		μs
t_{WED2}	100		ms
t_{WED3}	100		ms
t_{WED4}	500		ms
t_{WB}	200		ns
t_{VPH}	0		ns
t_{RHH}	0		ns

NOTE:

- Address inputs are "Don't Care" but must be held stable.
- If BYTE# is LOW, data and command are 8-bit. If BYTE# is HIGH, data is 16-bit and command is 8-bit.
- Either RP# at VHH or WP# HIGH unlocks the boot block.

**Figure 14: 40-Pin Plastic TSOP I
(10mm x 20mm)**

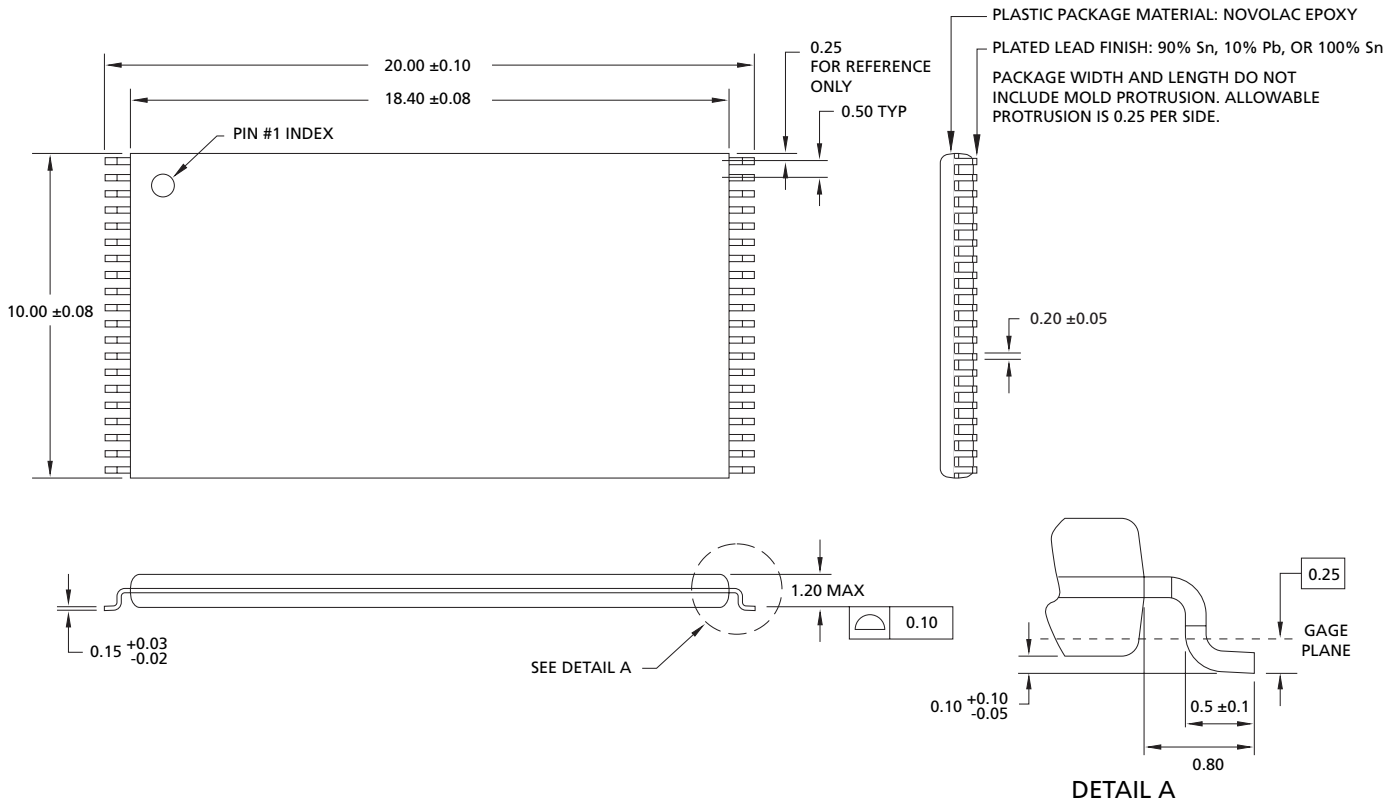

NOTE:

1. All dimensions in millimeters.
2. Package width and length do not include mold protrusion; allowable mold protrusion is .01" per side.

**Figure 15: 48-Pin Plastic TSOP I
(12mm x 20mm)**

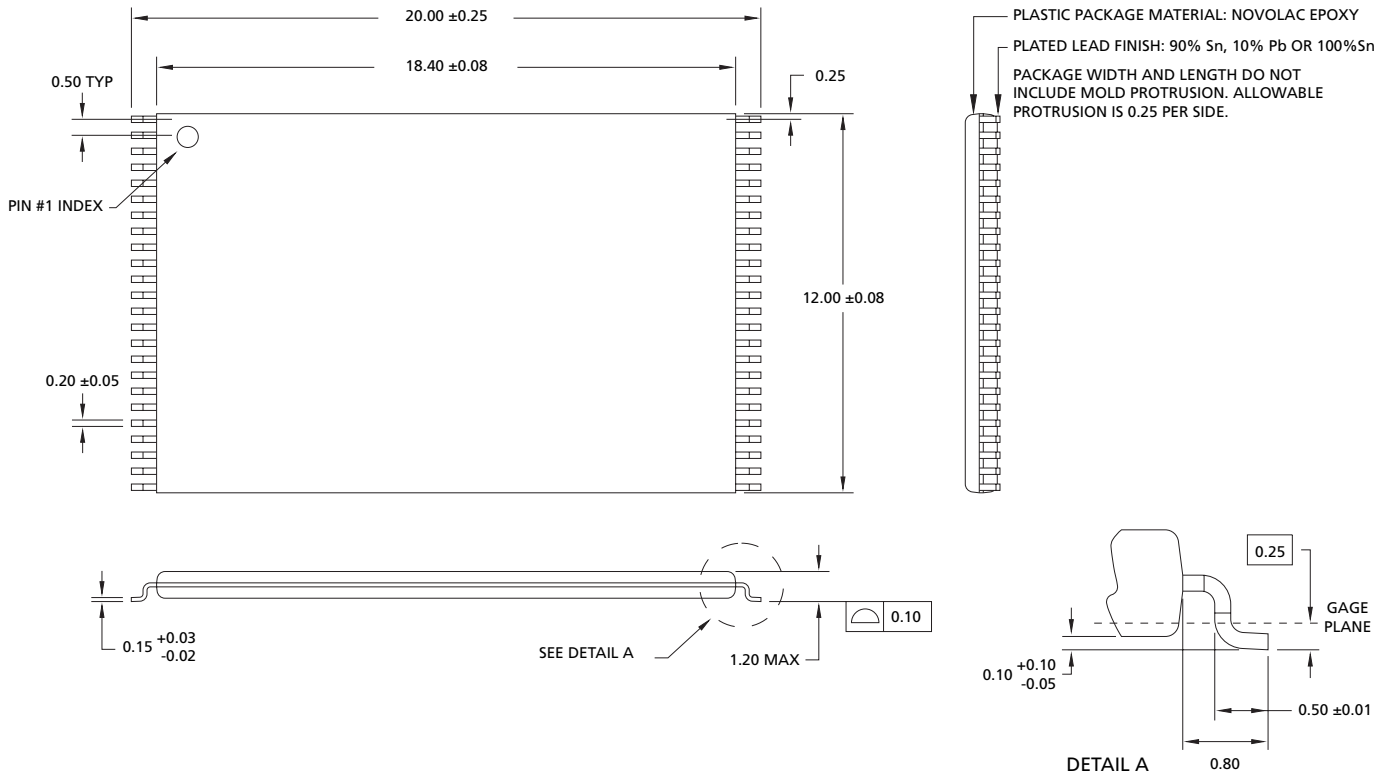

NOTE:

1. All dimensions in millimeters.
2. Package width and length do not include mold protrusion; allowable mold protrusion is .01" per side.

**Figure 16: 44-Pin Plastic SOP1
(500 mil)**

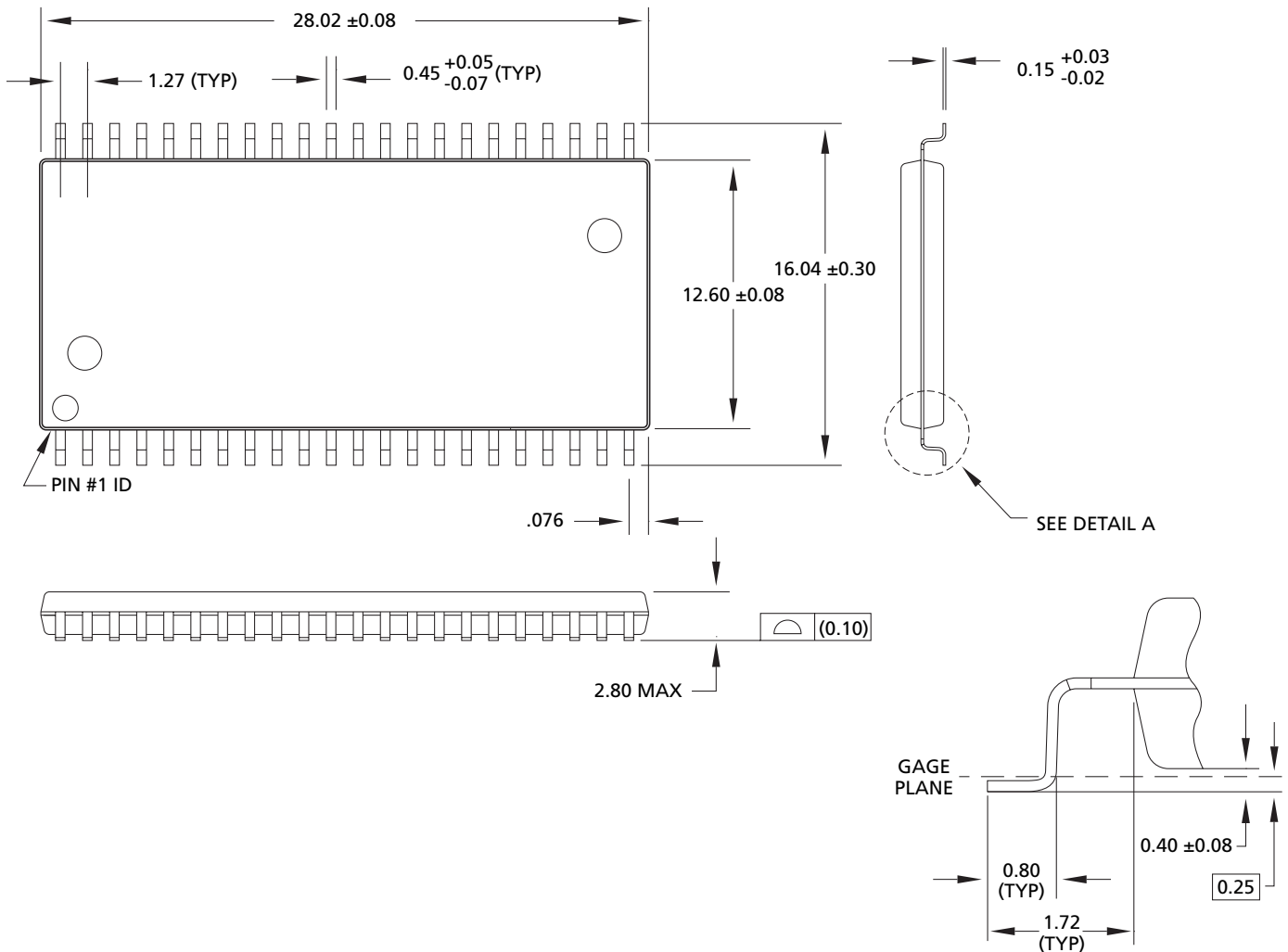

NOTE:

1. Not recommended for new designs.
2. All dimensions in millimeters.
3. Package width and length do not include mold protrusion; allowable mold protrusion is .01" per side.

Data Sheet Designation

Production: This data sheet contains minimum and maximum limits specified over the complete power supply and temperature range for production devices. Although considered final, these specifications are subject to change, as further product development and data characterization sometimes occur.



8000 S. Federal Way, P.O. Box 6, Boise, ID 83707-0006, Tel: 208-368-3900

E-mail: prodmktg@micron.com, Internet: <http://www.micron.com>, Customer Comment Line: 800-932-4992

Micron, the M logo, and the Micron logo are trademarks of Micron Technology, Inc.



All other trademarks are the property of their respective owners.

Revision History

Rev. E, Pub.6/04.	6/04
<ul style="list-style-type: none">• Update to ICC6 value• 40-pin TSOP and 48-pin TSOP package drawings have been updated	
Rev. D, Pub.3/04	3/04
<ul style="list-style-type: none">• Added lead-free packaging options	
Rev. 3, Pub. 10/01	10/01
<ul style="list-style-type: none">• Updated input capacitance spec• Changed access time to 90ns	
Rev. 2	3/01
<ul style="list-style-type: none">• Changed to 0.18μm process• 12V V_{PP} no longer supported• 10V \leq V_{HH} \leq 12V• V_{OH} \leq V_{CC} - 0.2V• ^tR_{WH} changed to 1μs from 800ns• ^tA_H changed to 10ns from 0ns• AC test output load CL changed to 50pF• Typical main BLOCK ERASE time changed to 1.5s from 1s• Typical main BLOCK WRITE time (byte mode) changed to 1s from 0.5s• Typical main BLOCK WRITE time (word mode) changed to 1s from 0.5s• MT28F800B3 only available in WG and SG packages• MT28F008B3 only available in VG package• Added 80ns access time for commercial and extended temperature ranges	

Looking for pricing, stock, or lifecycle information?

Click below to explore more details on WIN SOURCE:

-  [View MT28F008B3VG-9 T on WIN SOURCE](#)
-  [Micron Technology Inc. Information](#)

Optimize Your Supply Chain with WIN SOURCE Solutions

-  Global Sourcing Solution
-  Obsolete Management
-  Cost Control Management
-  Shortage Management
-  Alternative Solution
-  Excess Inventory Management