



**THE DATASHEET OF
DC2039A**



Multichemistry Buck Battery Charger Controller with Digital Telemetry System

FEATURES

- Multichemistry Li-Ion/Polymer, LiFePO₄, or Lead-Acid Battery Charger with Termination
- High Efficiency Synchronous Buck Battery Charger
- Digital Telemetry System Monitors V_{BAT} , I_{BAT} , R_{BAT} , NTC Ratio (Battery Temperature), V_{IN} , I_{IN} , V_{SYSTEM} , Die Temperature
- Coulomb Counter and Integrated 14-Bit ADC
- Wide Charging Input Voltage Range: 4.5V to 35V
- Wide Battery Voltage Range: Up to 35V
- Input Undervoltage Charge Current Limit Loop
- Maximum Power Point Tracking
- Optional I²C Serial Port Control
- Input Current Limit Prioritizes System Load Output
- Input and Output Ideal Diodes Provide Low Loss PowerPath™ Operation
- Instant-On Operation with Discharged Battery

APPLICATIONS

- Portable Medical Instruments/Military Equipment
- Industrial Handhelds/Lighting
- Ruggedized Notebook/Tablet Computers

DESCRIPTION

The LTC[®]4015 is a complete synchronous buck controller/charger with pin-selectable, chemistry specific charging and termination algorithms.

The LTC4015 can charge Li-Ion/Polymer, LiFePO₄, or lead-acid batteries. Battery charge voltage is pin selectable and I²C adjustable. Input current limit and charge current can be accurately programmed with sense resistors and can be individually adjusted via the I²C serial port. A digital telemetry system monitors all system power parameters.

Safety timer and current termination algorithms are supported for lithium chemistry batteries. The LTC4015 also includes automatic recharge, precharge (Li-Ion) and NTC thermistor protection. The LTC4015's I²C port allows user customization of charger algorithms, reading of charger status information, configuration of the maskable and programmable alerts, plus use and configuration of the Coulomb counter.

Available in a 38-Lead 5mm × 7mm QFN package.

LT, LT, LTC, LTM, Linear Technology and the Linear logo are registered trademarks and PowerPath is a trademark of Linear Technology Corporation. All other trademarks are the property of their respective owners.

TYPICAL APPLICATION

12V_{IN} 2-Cell Li-Ion 8A Step-Down Battery Charger Controller

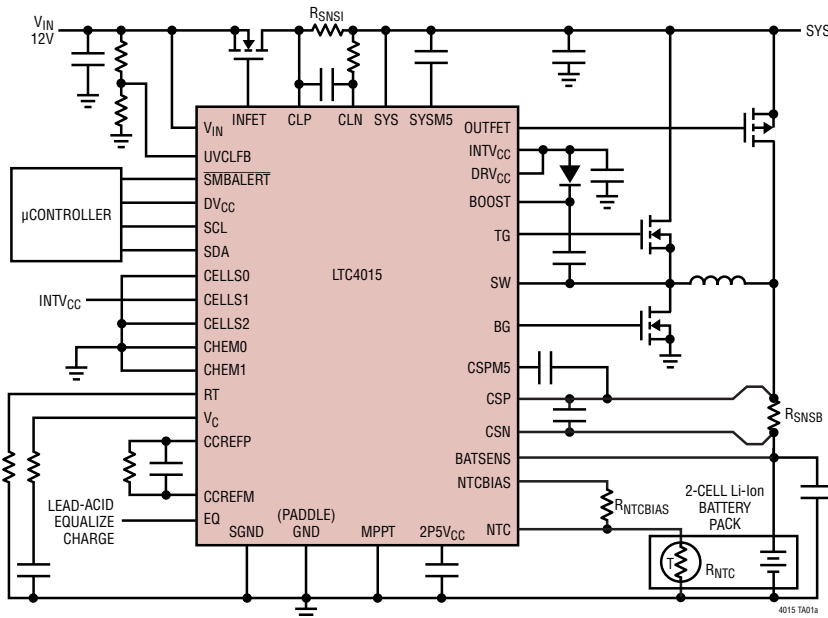

Step-Down Charger Efficiency and Coulomb Counter Error vs Battery Charge Current

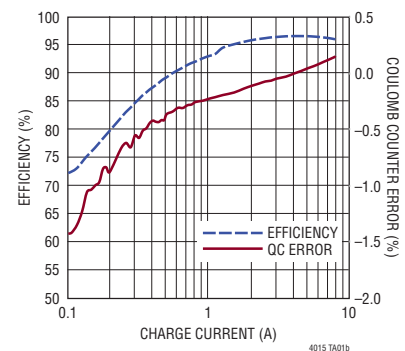

TABLE OF CONTENTS

Features	1
Applications	1
Typical Application	1
Description.....	1
Absolute Maximum Ratings.....	3
Order Information	3
Data Sheet Conventions	3
Pin Configuration	3
Electrical Characteristics	4
Typical Performance Characteristics	10
Pin Functions	13
Block Diagram.....	15
I2C Timing Diagram	16
Operation.....	17
Applications Information	42
Register Description	49
DETAILED Register Descriptions	55
Typical Applications	72
Package Description	74
Revision History	75
Typical Application	76
Related Parts	76

ABSOLUTE MAXIMUM RATINGS

(Notes 1, 5)

V_{IN} , CSN.....	-0.3V to 40V
BOOST to SW.....	-0.3 to 5.5V
BATSENS to CSN, CSP to CSN, CLP to CLN, CLP, CLN to SYS.....	$\pm 0.3V$
DV_{CC} , DRV_{CC}	-0.3V to 5.5V
CELLSO, CELLS1, CELLS2, CHEMO, CHEM1, MPPT, EQ.....	-0.3V to $INTV_{CC}$
SDA, SCL, $SMBALERT$	-0.3V to DV_{CC}
I_{UVCLFB} (Note 4).....	$\pm 200\mu A$
$INTV_{CC}$ Peak Output Current.....	100mA
Operating Junction Temperature Range (Notes 2,3).....	-40 to 125°C
Storage Temperature Range.....	-65 to 150°C

PIN CONFIGURATION

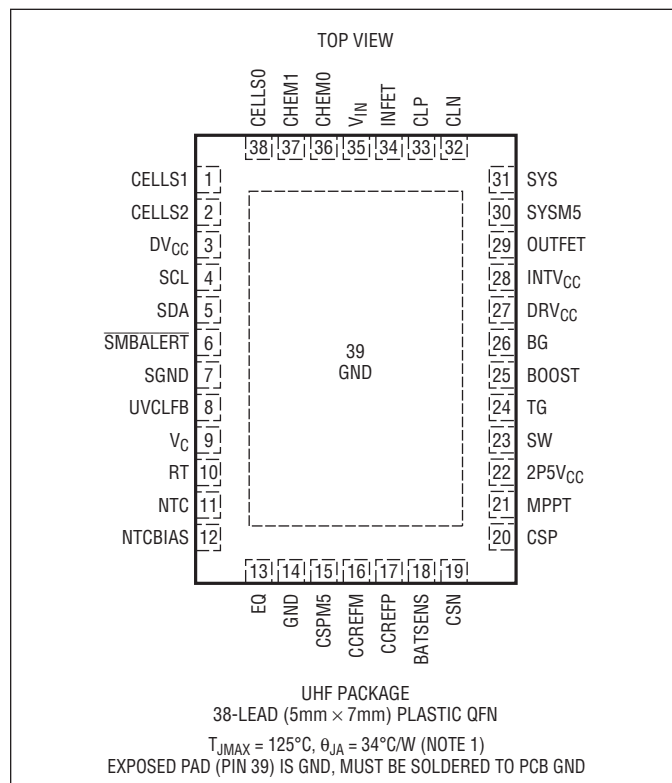

ORDER INFORMATION <http://www.linear.com/product/LTC4015#orderinfo>

LEAD FREE FINISH	TAPE AND REEL	PART MARKING*	PACKAGE DESCRIPTION	TEMPERATURE RANGE
LTC4015EUHF#PBF	LTC4015EUHF#TRPBF	4015	38-Lead (5mm × 7mm) Plastic QFN	-40°C to 125°C
LTC4015IUHF#PBF	LTC4015IUHF#TRPBF	4015	38-Lead (5mm × 7mm) Plastic QFN	-40°C to 125°C

Consult LTC Marketing for parts specified with wider operating temperature ranges. *The temperature grade is identified by a label on the shipping container.

For more information on lead free part marking, go to: <http://www.linear.com/leadfree/>

For more information on tape and reel specifications, go to: <http://www.linear.com/tapeandree/>. Some packages are available in 500 unit reels through designated sales channels with #TRMPBF suffix.

DATA SHEET CONVENTIONS

- $V_{PINNAME}$ and $I_{PINNAME}$ represents the voltage on a pin or the pin current; $V_{EQ} = EQ$ Pin Voltage.
- Hexadecimal numbers are prefixed with 0x; 0x10 is a hexadecimal 10
- Register symbol names will be capitalized. Symbols within a register will be lower case;
 $en_meas_sys_valid_alert$ is bit 15 in register EN_LIMIT_ALERTS (0x0D)
- $LiFePO_4$ is lithium iron phosphate, Li-Ion is used for both lithium-ion and lithium-ion polymer
- Lithium chemistries refers to $LiFePO_4$, lithium-ion, and lithium-ion polymer as a group.
- When a register name is used in square brackets, this means the 16 bit value associated with that register; For example [VBAT] is the 16 bit ADC measurement value of the per cell battery voltage.

ELECTRICAL CHARACTERISTICS The ● denotes the specifications which apply over the specified operating junction temperature range, otherwise specifications are at $T_A = 25^\circ\text{C}$. (Note 2), $DV_{CC} = 3.3\text{V}$, $UV_{CLFB} = 1.5$; $CELLS1 = INTV_{CC}$; EQ , $MPPT$, $CELLS0$, $CELLS2$, $CHEM0$, $CHEM1 = 0$; $RT = 95.3\text{k}$; $R_{CCREF} = 301\text{k}$, $R_{NTCBIAS} = R_{NTC} = 10\text{k}$; $BATSENS = CSN = CSP$; $DRV_{CC} = INTV_{CC}$; $SYS = CLP = CLN$. Conditions: Charging; $V_{IN} = 12\text{V}$, $SYS = 12\text{V}$, $BATSENS = 7.4\text{V}$ Battery Only; $V_{IN} = 0\text{V}$, $SYS = 8.4\text{V}$, $BATSENS = 8.4\text{V}$

SYMBOL	PARAMETER	CONDITIONS	MIN	TYP	MAX	UNITS
V_{IN}	Input Supply Voltage Range	Note 8	● 3.1		35	V
V_{BAT}	Battery Voltage Range	Note 8	●		35	V
$V_{CHARGE(TOL)}$	Charge Voltage, Regulated Battery per Cell Tolerance, All Chemistries	Li-Ion .4.2V per Cell; LiFePO ₄ 3.6V per Cell; Lead-Acid 2.2V per Cell	● -1.25		1.25	%
	Regulated Battery Charge Current Tolerance	Full-Scale $V_{CSP} - CSN / R_{SNSB}$	● -2.0		2.0	%
V_{SYS}	SYS Pin Voltage	Note 8	● 3.05		35	V

Quiescent Current $I_Q = I_{VIN} + I_{CLP} + I_{CLN} + I_{SYS} + I_{SW} + I_{CSP} + I_{CSN} + I_{BATSENS}$

	Battery Discharge Current (No Input Supply, Coulomb Counter Disabled)	Battery Only, Telemetry Inactive	●	112	325	μA
		Battery Only, Telemetry Active 1% Duty Cycle	●	140	364	μA
		Battery Only, Telemetry Active Continuously		2.84		mA
	I_Q , Charging	Charging, Switcher Suspended		3.00		mA
		Charging, $V_{BAT} > V_{CHARGE}$ (Note 7)		4.10		mA
	I_Q , Ship Mode	Ship Mode ($V_{IN} = 0$)	●	5	40	μA
I_{VIN}	V_{IN} Pin Current	Battery Only (No Input Supply)		-200	200	nA
		Charging		<140		μA
I_{SYS}	SYS Pin Current	Battery Only, Telemetry Off		100		μA
		Battery Only, Telemetry On		2.75		mA
		Charging, $V_{BAT} > V_{CHARGE}$ (Note 7)		3.65		mA
V_{IN_DUVLO}	V_{IN} to $V_{BATSENS}$ Differential Undervoltage (Must Be Satisfied for Charging)	Rising Threshold	●	140	200	mV
		Hysteresis		100	250	mV
V_{IN_OVLO}	Input Overvoltage Lockout (Inhibits Charger)	Rising Threshold	●	37.7	38.6	V
		Hysteresis		1.4	39.5	V

Input Undervoltage Current Limit

V_{UVCLFB}	UVCLFB Pin Regulation Range (8-Bit DAC)	V_{UVCLFB} Maximum Code 0xFF V_{UVCLFB} Minimum Code 0x00	●	1188	1200 4.6875	1212 mV
	UVCLFB Pin Regulation DAC LSB				4.6875	mV
	UVCLFB Pin Leakage Current	$V_{UVCLFB} = 1.2\text{V}$	●	-100	100	nA

Input Current Limit

	Regulated Input Current Limit Tolerance	Full-Scale $V_{CLP} - CLN / R_{SNSI}$	●	-2.0	2.0	%
I_{CL}	Input Current Limit Range	$I_{CL} = (V_{CLP} - CLN) / R_{SNSI}$		0.5 – 32		mV / R_{SNSI}
	Input Current Limit LSB Step Size			0.5		mV / R_{SNSI}
	CLP Input Current	$V_{CLP} = 12\text{V}$, $V_{CLP} - CLN = 32\text{mV}$		45		μA
	CLN Input Current	$V_{CLP} = 12\text{V}$, $V_{CLP} - CLN = 32\text{mV}$		-100	100	nA
	CLP, CLN Common Mode Range	Note 8		4	35	V

ELECTRICAL CHARACTERISTICS The ● denotes the specifications which apply over the specified operating junction temperature range, otherwise specifications are at $T_A = 25^\circ\text{C}$. (Note 2), $DV_{CC} = 3.3\text{V}$, $UV_{CLFB} = 1.5$; $CELLS1 = INTV_{CC}$; EQ , $MPPT$, $CELLS0$, $CELLS2$, $CHEM0$, $CHEM1 = 0$; $RT = 95.3\text{k}$; $R_{CCREF} = 301\text{k}$, $R_{NTCBIAS} = R_{NTC} = 10\text{k}$; $BATSENS = CSN = CSP$; $DRV_{CC} = INTV_{CC}$; $SYS = CLP = CLN$. Conditions: Charging; $V_{IN} = 12\text{V}$, $SYS = 12\text{V}$, $BATSENS = 7.4\text{V}$ Battery Only; $V_{IN} = 0\text{V}$, $SYS = 8.4\text{V}$, $BATSENS = 8.4\text{V}$

SYMBOL	PARAMETER	CONDITIONS	MIN	TYP	MAX	UNITS
INTV_{CC} Regulator (SYS is Supply Pin for This Regulator)						
V_{INTVCC}	Internal Regulator Output Voltage	No Load		5		V
	Load Regulation	$I_{INTVCC} = 50\text{ mA}$		1.5	2.5	%
V_{INTVCC_CUVLO}	INTV _{CC} Undervoltage Charger Lockout	Rising Threshold Hysteresis	● 4.2	4.3 0.3	4.4	V V
V_{INTVCC_TUVLO}	INTV _{CC} Undervoltage Telemetry System Lockout	Rising Threshold Hysteresis	● 2.75	2.85 0.12	2.95	V V
DRV_{CC} INPUT (External Supply or Supplied by INTV_{CC})						
V_{DRVCC}	DRV _{CC} Supply Voltage		4.3		5.5	V
	DRV _{CC} Undervoltage Lockout	Rising Threshold Hysteresis	● 4.1	4.2 0.3	4.3	V V
Battery Charger (All Chemistries)						
I_{CHARGE}	Battery Charge Current Range, Battery Charge Current Resolution	$V_{CSP} > 2.6\text{V}$ (Note 10)		1 – 32 1		mV/R _{SNSB} mV/R _{SNSB}
	Peak Low V_{CSP} Charge Current	$V_{CSP} < 2.4\text{V}$		7.0		mV/R _{SNSB}
	$I_{BATSENS} + I_{CSP} + I_{CSN}$	Charger Suspended (Telemetry Active) $V_{IN}, V_{SYS} = 12\text{V}$, $V_{BATSENS} = 7.4\text{V}$ $V_{IN}, V_{SYS} = 35\text{V}$, $V_{BATSENS} = 34\text{V}$ (9 Cells)		110 200		μA μA
Lithium-Ion/Lithium Polymer Battery Charger						
Lithium-Ion/Lithium Polymer Programmable, CHEM1, CHEM0 = [LL] (Note 9)						
	Li-Ion Charge Voltage Max DAC Setting	Code 11111 (Note 11)		4.2		V/Cell
	Li-Ion Charge Voltage Min DAC Setting	Code 00000 (Note 11)		3.8125		V/Cell
	Li-Ion Charge Voltage DAC LSB			12.5		mV
	Li-Ion Recharge Voltage	Percent of Charge Voltage		97.5		%
	Charge C/x Termination Setting	$V_{CSP-CSN}$ (I^2C Termination Option)		3.2		mV
Lithium-Ion/Lithium Polymer Fixed 4.2, 4.1, 4.0 Charge Voltage, CHEM1, CHEM0 = [HH,LZ,ZL] (Note 9)						
	4.2V Fixed Li-Ion Charge Voltage	CHEM1,0 = [H,H] (Note 11)		4.200		V/Cell
	4.2V Fixed Li-Ion Recharge Voltage	CHEM1,0 = [H,H]		4.095		V/Cell
	4.1V Fixed Li-Ion Charge Voltage	CHEM1,0 = [L,Z] (Note 11)		4.100		V/Cell
	4.1V Fixed Li-Ion Recharge Voltage	CHEM1,0 = [L,Z]		4.000		V/Cell
	4.0V Fixed Li-Ion Charge Voltage	CHEM1,0 = [Z,L] (Note 11)		4.000		V/Cell
	4.0V Fixed Li-Ion Recharge Voltage	CHEM1,0 = [Z,L]		3.900		V/Cell
Lithium-Ion/Lithium Polymer, CHEM1, CHEM0 = [LL, HH, LZ, ZL] (Note 9)						
	Low Battery Precharge Threshold	Charge Voltage = 4.2V		2.85		V/Cell
	Low Battery Precharge Hysteresis	Charge Voltage = 4.2V		50		mV/Cell
	Low Battery Precharge Current	I_{CHARGE} Set to 32 mV/R _{SNSB}		3		mV/R _{SNSB}
	Max Charge Time			18.2		hrs
	Charge Termination Timer	(Default Termination)		4		hrs

ELECTRICAL CHARACTERISTICS The ● denotes the specifications which apply over the specified operating junction temperature range, otherwise specifications are at $T_A = 25^\circ\text{C}$. (Note 2), $DV_{CC} = 3.3\text{V}$, $UV_{CLFB} = 1.5$; $CELLS1 = INTV_{CC}$; EQ, MPPT, $CELLS0$, $CELLS2$, $CHEM0$, $CHEM1 = 0$; $RT = 95.3\text{k}$; $R_{CCREF} = 301\text{k}$, $R_{NTCBIAS} = R_{NTC} = 10\text{k}$; $BATSENS = CSN = CSP$; $DRV_{CC} = INTV_{CC}$; $SYS = CLP = CLN$. Conditions: Charging; $V_{IN} = 12\text{V}$, $SYS = 12\text{V}$, $BATSENS = 7.4\text{V}$ Battery Only; $V_{IN} = 0\text{V}$, $SYS = 8.4\text{V}$, $BATSENS = 8.4\text{V}$

SYMBOL	PARAMETER	CONDITIONS	MIN	TYP	MAX	UNITS	
LiFePO₄ Battery Charger							
LiFePO₄, Programmable, CHEM1, CHEM0 = [LH] (Note 9)							
	LiFePO ₄ Charge Voltage Max DAC setting	Code 11111 (Note 11)		3.8		V/Cell	
	LiFePO ₄ Charge Voltage Min DAC setting	Code 00000 (Note 11)		3.4125		V/Cell	
	LiFePO ₄ Charge Voltage DAC LSB			12.5		mV	
	LiFePO ₄ Recharge Voltage	POR Value I ² C Programmable		3.35		V/Cell	
$V_{LiFePO4-C/x}$	Charge Termination C/x Threshold	$V_{CSP-CSN}$ (I ² C Programmable)		3.2		mV	
LiFePO₄ Fixed Standard Charge, Fixed Fast Charge, CHEM1, CHEM0 = [ZH, HZ] (Note 9)							
	LiFePO ₄ Fixed Fast Charge Absorb Voltage	CHEM1, CHEM0 = [HZ] Only (Note 11)		3.8		V/Cell	
	LiFePO ₄ Charge Voltage	CHEM1, CHEM0 = [ZH, HZ] (Note 11)		3.6		V/Cell	
	LiFePO ₄ Recharge Voltage	CHEM1, CHEM0 = [ZH, HZ] (Note 11)		3.35		V/Cell	
LiFePO₄, CHEM1, CHEM0 = [LH, HZ, ZH] (Note 9)							
	Max Charge Time			18.2		hrs	
$V_{LiFePO4-T(CV)}$	Charge Termination Time			1		hrs	
Lead-Acid Battery Charger							
Lead-Acid Fixed, CHEM1, CHEM0 = [ZZ] (Note 9)							
$V_{Lead_Acid_Vcharge}$	Lead-Acid V_{CHARGE} , Equalization	(Note 11)		2.6		V/Cell	
	Lead-Acid V_{CHARGE} , Absorption	(Note 11)		2.4		V/Cell	
	Lead-Acid V_{CHARGE} , CV	(Note 11)		2.2		V/Cell	
	Lead-Acid Temperature Compensation			-3.65		mV/Cell/°C	
Lead-Acid Programmable, CHEM1, CHEM0 = [HL] (Note 9)							
$V_{Lead_Acid_Vcharge}$	Lead-Acid V_{CHARGE} DAC Maximum	Code 111111 (Note 11)		2.6		V/Cell	
	Lead-Acid V_{CHARGE} DAC Minimum	Code 000000 (Note 11)		2.0		V/Cell	
	Lead-Acid V_{CHARGE} DAC Resolution			9.5		mV	
	Lead-Acid Temperature Comp	Temperature Comp Enabled		-3.65		mV/Cell/°C	
Thermistor (NTC) BIAS							
$V_{NTCBIAS}$	Applied NTC Bias Voltage	Internally Switched to 1.2V		1.2		V	
I_{NTC}	NTC Leakage Current		-50		50	nA	
SYSM5, CSPM5 Regulators							
$-5V_{VINM5}$	$V_{SYS} - V_{SYSM5}$, $V_{CSP} - V_{CSPM5}$	No Load		4.8		V	
Power Path/Ideal Diode Controllers							
V_{FTO}	Forward Turn-On Voltage			50		mV	
V_{FR}	Forward Regulation			15		mV	
V_{RTO}	Reverse Turn-Off			-30		mV	
$t_{IF(ON)}$	INFET Turn-On Time	INFET - $V_{IN} > 3\text{V}$, $C_{INFET} = 3.3\text{nF}$		550		μs	
$t_{IF(OFF)}$	INFET Turn-Off Time	INFET - $V_{IN} < 1\text{V}$, $C_{INFET} = 3.3\text{nF}$		2		μs	
$t_{OF(ON)}$	OUTFET Turn-On Time	VBAT - OUTFET $> 3\text{V}$, $C_{OUTFET} = 3.3\text{nF}$		2.3		μs	
$t_{OF(OFF)}$	OUTFET Turn-Off Time	VBAT - OUTFET $< 1\text{V}$, $C_{OUTFET} = 3.3\text{nF}$		1.9		μs	
Inductor Current Regulation							
I_{LIM}	Cycle by Cycle Max Charge Current	Note 5	●	47	52	57	mV/R _{SNSB}
I_{REV}	Reverse Inductor Current		●	3.8	7.0	10	mV/R _{SNSB}

ELECTRICAL CHARACTERISTICS The ● denotes the specifications which apply over the specified operating junction temperature range, otherwise specifications are at $T_A = 25^\circ\text{C}$. (Note 2), $DV_{CC} = 3.3\text{V}$, $UV_{CLFB} = 1.5$; $CELLS1 = INTV_{CC}$; EQ, MPPT, $CELLS0, CELLS2, CHERO, CHERO1 = 0$; $R_T = 95.3\text{k}$; $R_{CCREF} = 301\text{k}$, $R_{NTCBIAS} = R_{NTC} = 10\text{k}$; $BATSENS = CSN = CSP$; $DRV_{CC} = INTV_{CC}$; $SYS = CLP = CLN$. Conditions: Charging; $V_{IN} = 12\text{V}$, $SYS = 12\text{V}$, $BATSENS = 7.4\text{V}$ Battery Only; $V_{IN} = 0\text{V}$, $SYS = 8.4\text{V}$, $BATSENS = 8.4\text{V}$

SYMBOL	PARAMETER	CONDITIONS	MIN	TYP	MAX	UNITS
Oscillator						
f_{OSC}	Switching Frequency	$R_T = 95.3\text{k}$	● 475	500	525	kHz
f_{MAX}	Maximum Programmable Frequency	$R_T = 47.5\text{k}$		1		MHz
f_{MIN}	Minimum Programmable Frequency	$R_T = 237\text{k}$		200		kHz
Gate Drivers						
R_{UP-TG}	TG Pull-Up On-Resistance			2.0		Ω
$R_{DOWN-TG}$	TG Pull-Down On-Resistance			0.5		Ω
R_{UP-BG}	BG Pull-Up On-Resistance			2.0		Ω
$R_{DOWN-BG}$	TG Pull-Down On-Resistance			0.5		Ω
t_{R-TG}	TG 10% to 90% Rise Time	$C_{LOAD} = 3.3\text{nF}$		20		ns
t_{F-TG}	TG 90% to 10% Fall Time	$C_{LOAD} = 3.3\text{nF}$		10		ns
t_{R-BG}	BG 10% to 90% Rise Time	$C_{LOAD} = 3.3\text{nF}$		20		ns
t_{F-BG}	BG 90% to 10% Fall Time	$C_{LOAD} = 3.3\text{nF}$		10		ns
t_{NO}	Non-Overlap Time			60		ns
$t_{ON(MIN)}$	Minimum On-Time			140		ns
DC_{MAX}	Maximum Duty Cycle			98.4		%
VC Error Amplifier						
g_m	Transconductance to V_C pin $g_m(V_{CSP-CSM})$ (Constant-Current) $g_m(V_{BATSENS})$ (Constant-Voltage Lithium) $g_m(V_{BATSENS})$ (Constant-Voltage LA) $g_m(V_{UVCLFB})$ (Input Voltage Regulation) $g_m(V_{CLP-CLM})$ (Input Current Limiting)	2 Cell; ($g_m = 1.06^{-3} \cdot 2 / (7 \cdot \text{Cell Count})$) 6 Cell; ($g_m = 1.06^{-3} \cdot 3 / (7 \cdot \text{Cell Count})$)		4.10 0.15 0.08 1.06 4.10		mmho mmho mmho mmho mmho
Telemetry A/D Measurement Subsystem, Battery Only Mode						
V_{ERR}	Measurement Error (Note 6)	$V_{IN} = 1\text{V}$ $V_{IN} = 35\text{V}$		± 100 ± 1.5		mV %
		$V_{SYS} = 2.5\text{V}$ $V_{SYS} = 35\text{V}$		± 100 ± 1.5		mV %
		$V_{BAT} = 1.75\text{V}$, 1 Cell Li-Ion $V_{BAT} = 35\text{V}$, 9 Cell Li-Ion		± 50 ± 1.5		mV %
		$V_{CLP-CLN} = 0\text{mV}$ $V_{CLP-CLN} = 32\text{mV}$		± 200 ± 2.5		μV %
		$V_{CSP-CSN} = 0\text{mV}$ $V_{CSP-CSN} = 32\text{mV}$		± 200 ± 2.5		μV %
		NTC/NTCBIAS = 50%, 75% NTC/NTCBIAS = 5%		± 2 ± 3.5		% %

ELECTRICAL CHARACTERISTICS The ● denotes the specifications which apply over the specified operating junction temperature range, otherwise specifications are at $T_A = 25^\circ\text{C}$. (Note 2), $DV_{CC} = 3.3\text{V}$, $UV_{CLFB} = 1.5$; $CELLS1 = INTV_{CC}$; EQ, MPPT, $CELLS0, CELLS2, CHEM0, CHEM1 = 0$; $RT = 95.3\text{k}$; $R_{CCREF} = 301\text{k}$, $R_{NTCBIAS} = R_{NTC} = 10\text{k}$; $BATSENS = CSN = CSP$; $DRV_{CC} = INTV_{CC}$; $SYS = CLP = CLN$. Conditions: Charging; $V_{IN} = 12\text{V}$, $SYS = 12\text{V}$, $BATSENS = 7.4\text{V}$ Battery Only; $V_{IN} = 0\text{V}$, $SYS = 8.4\text{V}$, $BATSENS = 8.4\text{V}$

SYMBOL	PARAMETER	CONDITIONS	MIN	TYP	MAX	UNITS
Coulomb Counter						
V_{SENSE}	Sense Voltage Differential Input Range	$V_{CSP-CSN}$			± 50	mV
q_{LSB}	Charge Measurement Resolution	Prescaler M = 512 (Default)		0.017		mV/hr
TCE	Total Charge Error	$10\text{mV} \leq V_{SENSE} \leq 50\text{mV}$			± 1.5	%
		$10\text{mV} \leq V_{SENSE} \leq 50\text{mV}$	●		± 2.5	%
		$V_{SENSE} = 1\text{mV}$		<1.0		%
I_{QC_CSP}	I_Q^- Coulomb Counter	$V_{SENSE} = 30\text{mV}$, Battery Only		78		μA
CELLS0, CELLS1, CELLS2, CHEM0, CHEM1 Programming Input Pins (Note 9)						
V_{IHPP}	Input High Threshold	$INTV_{CC} - V_{PIN}$	●		0.3	V
V_{ILPP}	Input Low Threshold	V_{PIN}	●		0.3	V
R_{IZPP}	Input High-Z Test Resistance	Internal 50k/50k Resistor Divider Applied to Inputs During Chemistry/Cell Read		25		k Ω
MPPT, EQ Input Pins						
	MPPT, EQ Input High Threshold		●	1.1		V
	MPPT, EQ Input Low Threshold		●		0.2	V
	MPPT, EQ Pin Leakage Current	$V_{EQ}, V_{MPPT} = 5\text{V}$		0	1	μA
SMBALERT Pin Characteristics						
$I_{SMBALERT}$	SMBALERT Pin Leakage Current	$V_{SMBALERT} = 5\text{V}$		0	1	μA
$V_{SMBALERT}$	SMBALERT Pin Output Low Voltage	$I_{SMBALERT} = 1\text{mA}$		65	100	mV
I²C Port, SDA, SCL						
DV_{CC}	I ² C Logic Reference Level		1.6		5.5	V
I_{DVCCQ}	DV_{CC} Current	SCL/SDA = 0kHz		0		μA
ADDRESS	I ² C Address			1101_000[R/W]b		
V_{IH12C}	Input High Threshold				70	% DV_{CC}
V_{IL12C}	Input Low Threshold		30			% DV_{CC}
I_{IH12C}	Input Leakage High		-1		1	μA
I_{IL12C}	Input Leakage Low		-1		1	μA
V_{OL12C}	Digital Output Low (SDA)	$I_{SDA} = 3\text{mA}$			0.4	V
F_{SCL}	SCL Clock Frequency				400	kHz
t_{LOW}	LOW Period of SCL Clock		1.3			μs
t_{HIGH}	HIGH Period of SCL Clock		0.6			μs
t_{BUF}	Bus Free Time Between Start and Stop Conditions		1.3			μs
$t_{HD(STA)}$	Hold Time, After (Repeated) Start Condition		0.6			μs
$t_{SU(STA)}$	Setup Time After a Repeated Start Condition		0.6			μs
$t_{SU(STO)}$	Stop Condition Set-Up Time		0.6			μs

ELECTRICAL CHARACTERISTICS The ● denotes the specifications which apply over the specified operating junction temperature range, otherwise specifications are at $T_A = 25^\circ\text{C}$. (Note 2), $DV_{CC} = 3.3\text{V}$, $UV_{CLFB} = 1.5$; $CELLS1 = INTV_{CC}$; EQ , $MPPT$, $CELLS0$, $CELLS2$, $CHEM0$, $CHEM1 = 0$; $RT = 95.3\text{k}$; $R_{CCREF} = 301\text{k}$, $R_{NTCBIAS} = R_{NTC} = 10\text{k}$; $BATSENS = CSN = CSP$; $DRV_{CC} = INTV_{CC}$; $SYS = CLP = CLN$. Conditions: Charging; $V_{IN} = 12\text{V}$, $SYS = 12\text{V}$, $BATSENS = 7.4\text{V}$ Battery Only; $V_{IN} = 0\text{V}$, $SYS = 8.4\text{V}$, $BATSENS = 8.4\text{V}$

SYMBOL	PARAMETER	CONDITIONS	MIN	TYP	MAX	UNITS
$t_{HD(DAT(OUT))}$	Output Data Hold Time		0		900	ns
$t_{HD(DAT(IN))}$	Input Data Hold Time		0			ns
$t_{SU(DAT)}$	Data Set-Up Time		100			ns
t_{SP}	Input Spike Suppression Pulse Width				50	ns

Note 1: Stresses beyond those listed under Absolute Maximum Ratings may cause permanent damage to the device. Exposure to any Absolute Maximum Rating condition for extended periods may affect device reliability and lifetime.

Note 2: The LTC4015 is tested under pulsed load conditions such that $T_J \approx T_A$. The LTC4015E is guaranteed to meet specifications from 0°C to 85°C junction temperature. Specifications over the -40°C to 125°C operating junction temperature range are assured by design, characterization and correlation with statistical process controls. The LTC4015I is guaranteed over the -40°C to 125°C operating junction temperature range. Note that the maximum ambient temperature consistent with these specifications is determined by specific operating conditions in conjunction with board layout, the rated package thermal impedance and other environmental factors. The junction temperature (T_J , in $^\circ\text{C}$) is calculated from the ambient temperature (T_A , in $^\circ\text{C}$) and power dissipation (PD, in Watts) according to the formula:

$$T_J = T_A + (PD \cdot \theta_{JA})$$

where $\theta_{JA} = 34^\circ\text{C/W}$ for the UHF package.

Note 3: The LTC4015 includes overtemperature protection that is intended to protect the device during momentary overload conditions. The maximum rated junction temperature will be exceeded when this protection is active. Continuous operation above the specified absolute maximum operating junction temperature may impair device reliability or permanently damage the device.

Note 4: UV_{CLFB} is internally clamped above the maximum UV_{CLFB} regulation point (2.5V at 200 μA nominally). Maximum input current must be limited to 200 μA when this clamp is reached.

Note 5: The current limit features of this part are intended to protect the IC from short term or intermittent fault conditions. Continuous operation above the maximum specified pin current may result in device degradation or failure.

Note 6: Measurement error is the magnitude of the difference between the actual measured value and the ideal value. Error for $V_{CLP-CLN}$ and $V_{CSP-CSN}$ is expressed in μV , a conversion to an equivalent current may be made by dividing by the sense resistors, R_{SNSI} and R_{SNSB} , respectively.

Note 7: V_{CHARGE} is the battery charge voltage (or CV, constant-voltage) target. V_{BAT} is the battery voltage. Dynamic supply current is higher due to the gate charge being delivered at the switching frequency. See the Applications Information section.

Note 8: V_{IN} , or V_{BAT} for battery only operation, may be connected to any suitable DC power source from 2.8V to 35V such that the voltage at V_{SYS} is high enough to allow $INTV_{CC}$ to support the desired mode of operation. In order for the telemetry system to operate, $INTV_{CC}$ must exceed the telemetry undervoltage lockout (V_{INTVCC_TUVLO}). In order for the battery charger to operate, $INTV_{CC}$ must exceed the charger undervoltage lockout (V_{INTVCC_CUVLO}). Allowing for 0.3V of drop from V_{IN} to $INTV_{CC}$, these modes require a minimum input voltage of 3.1V and 4.35V, respectively. Additionally the V_{IN} to $V_{BATSENS}$ (V_{IN_DULVO}) differential must also be satisfied for charging.

Note 9: Chemistry selection is made using the $CHEM1$ and $CHEM0$ pins. These are three-state pins used by the LTC4015 to select of one of nine chemistry specific charging algorithms. These pins should be hard wired to GND(L), $INTV_{CC}(H)$, or left open ($Z > 1000\text{k}\Omega$).

Note 10: I_{CHARGE} is the battery charge current (or CC, constant-current) target. I_{CHG} is the charge current when charging.

Note 11: Charge voltage tolerance is $V_{CHARGE(TOL)}$ which is specified at the beginning of the electrical table. The LTC4015 is not a substitute for pack protection! The 4015 does not monitor or balance individual cells – the full stack voltage is divided by number of cells for simplicity only.

TYPICAL PERFORMANCE CHARACTERISTICS

$T_A = 25^\circ\text{C}$, application circuit 1 unless otherwise noted.

Lead-Acid Charging Profile
Voltage, Current vs Time

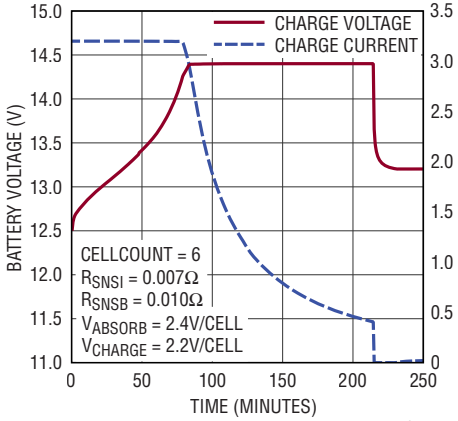

Li-Ion Charging Profile
Voltage, Current vs Time

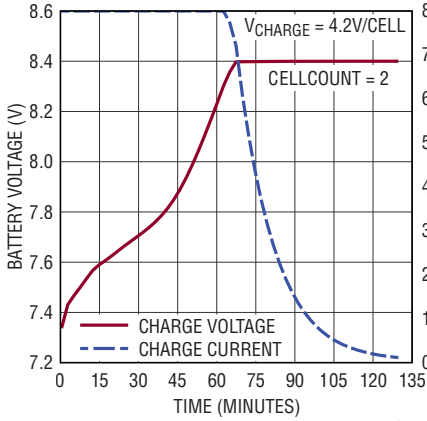

LiFePO₄ Charging Profile
Voltage, Current vs Time

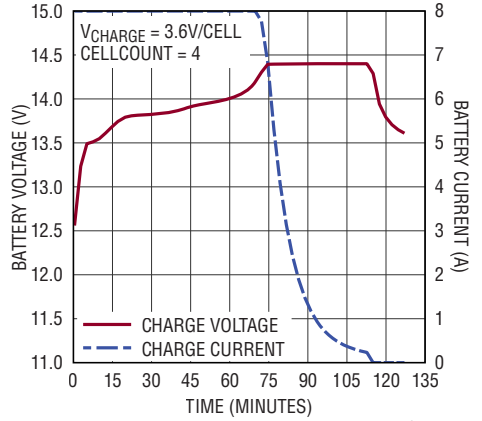

V_{IN} (Resistive), MPPT Enabled
Charger On/Off

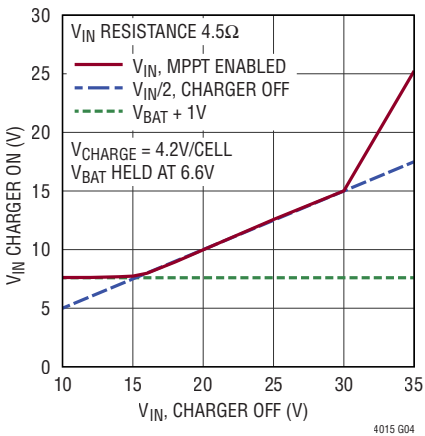

Li-Ion Charging Efficiency vs V_{IN}

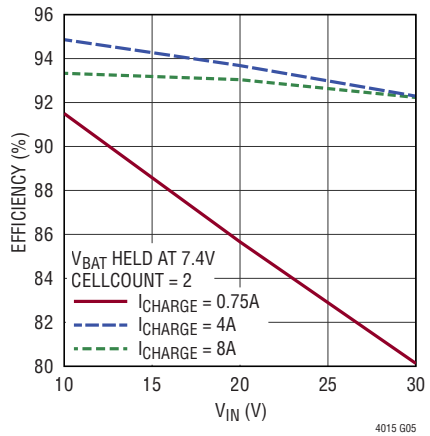

Lead-Acid Charging Efficiency
vs I_{CHARGE}

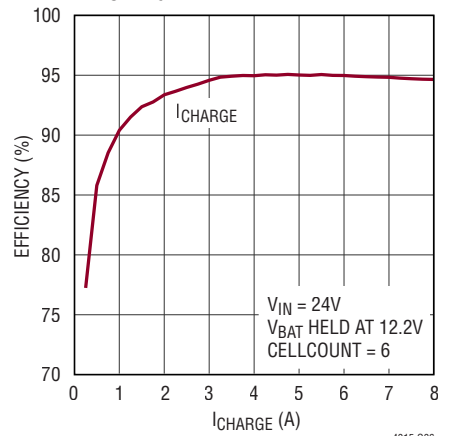

LiFePO₄ Charging Efficiency
vs I_{CHARGE}

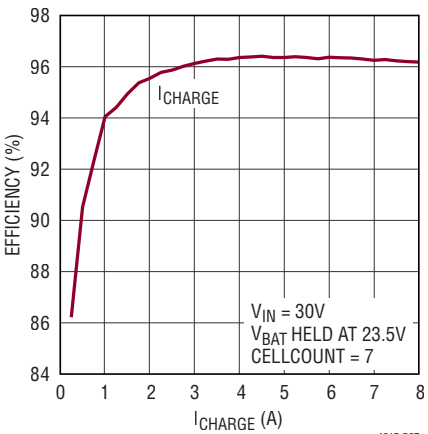

Charge Voltage (CV Mode)
vs Junction Temperature

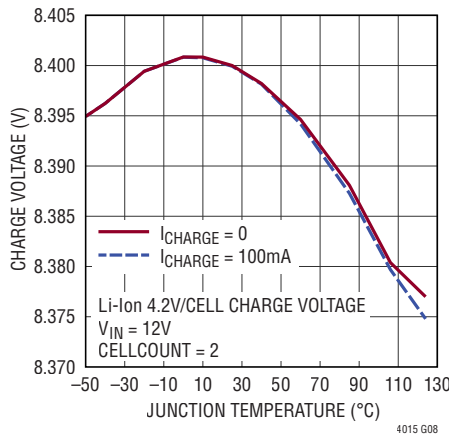

V_{RSNSB} Current (CC Mode)
vs Junction Temperature

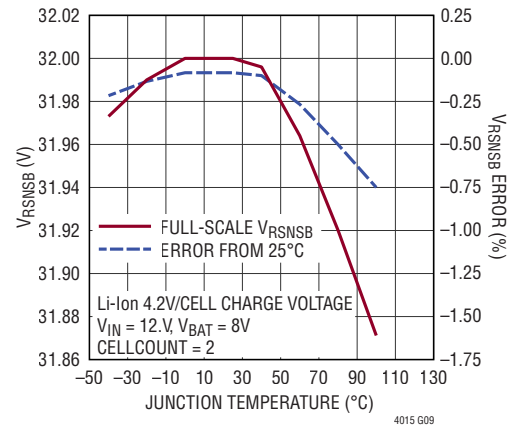

TYPICAL PERFORMANCE CHARACTERISTICS

$T_A = 25^\circ\text{C}$, application circuit 1 unless otherwise noted.

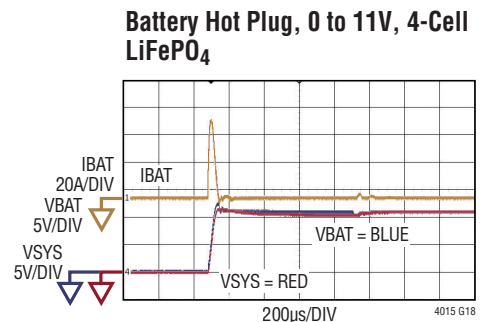
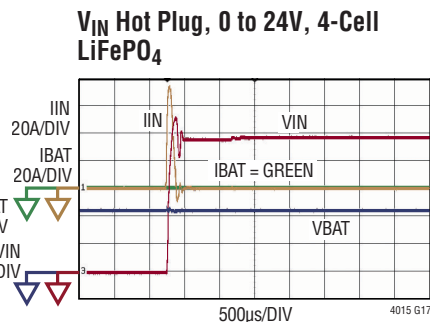
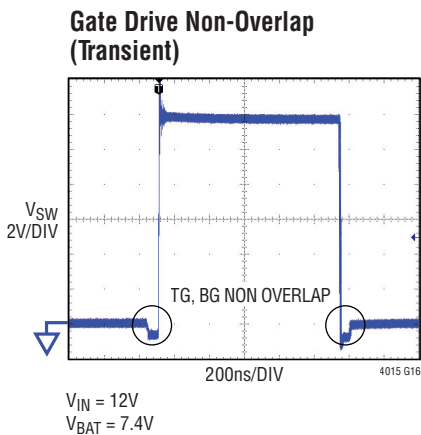
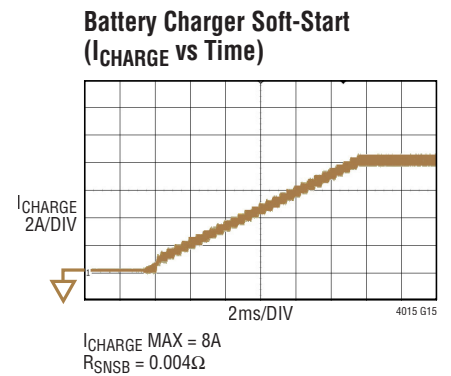
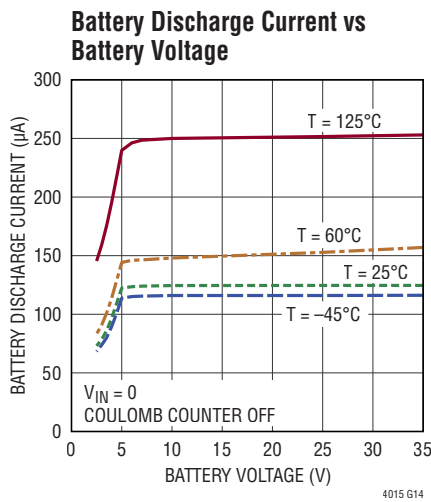
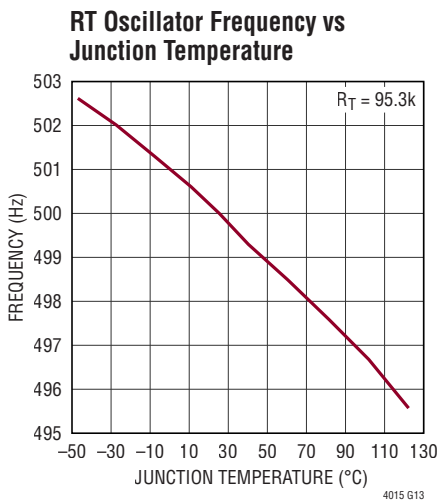
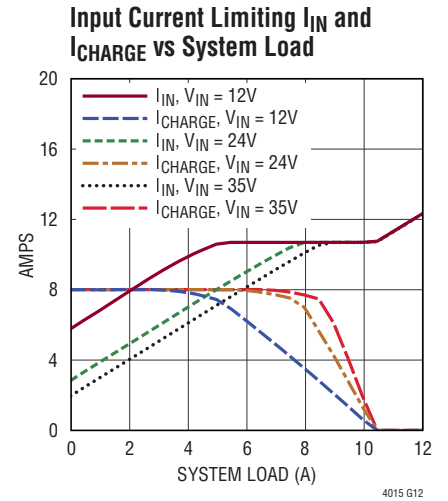
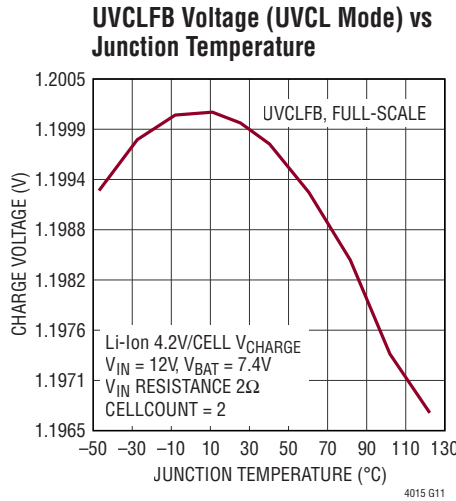
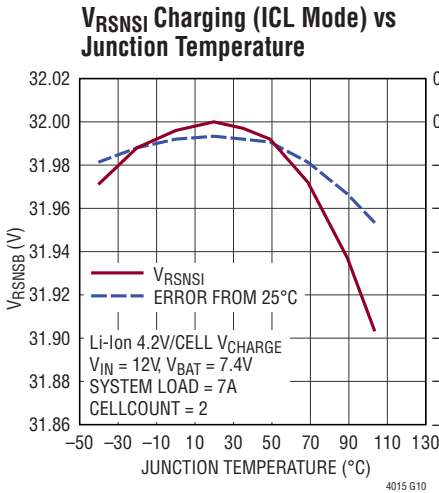

TYPICAL PERFORMANCE CHARACTERISTICS

**Start-Up from 24V V_{IN} Hot Plug,
 $I_{CHARGE} = 8A$ ($R_{SNSB} = 0.004\Omega$)**

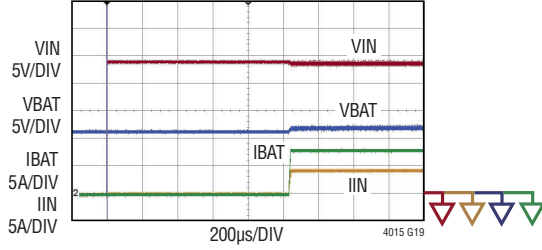

**Ship Mode Battery Discharge
Current vs Battery Voltage**

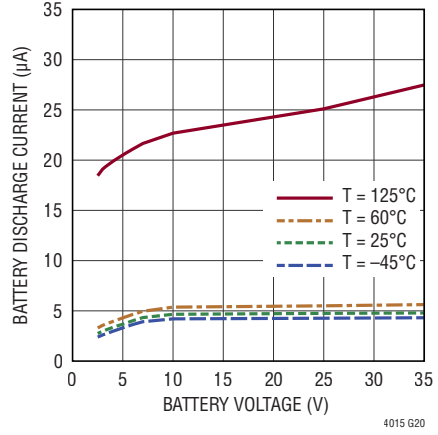

**MPPT Algorithm Using UVCL DAC
Sweep to Find MPP**

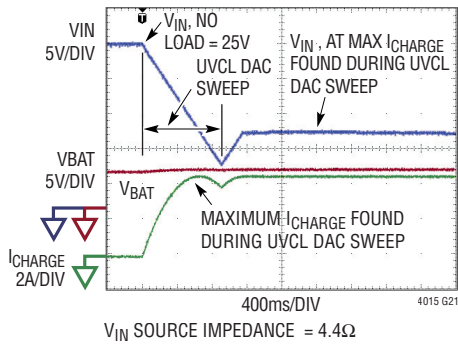

**Coulomb Counter Accuracy vs
 $V_{CSP} - V_{CSN}$**

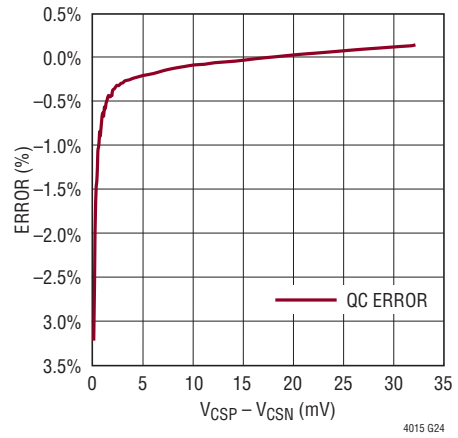

PIN FUNCTIONS

CELLS1 (Pin 1): Number of Cells Select Pin. Three-state pin used in combination with CELLS0 and CELLS2 to set the total number of battery cells.

CELLS2 (Pin 2): Number of Cells Select Pin. Three-state pin used in combination with CELLS0 and CELLS1 to set the total number of battery cells.

DV_{CC} (Pin 3): Logic Supply for the I²C Serial Port. DV_{CC} sets the reference level of the SDA and SCL pins for I²C compliance. It must be connected to the same power supply used to power the I²C pull up resistors. If the I²C port is unused connect this pin to INTV_{CC}, do not float.

SCL (Pin 4): Clock Input for the I²C Serial Port. The I²C input levels are scaled with respect to DV_{CC} for I²C compliance. If the I²C port is unused connect this pin to INTV_{CC}, do not float.

SDA (Pin 5): Data Input/Output for the I²C serial port. The I²C input levels are scaled with respect to DV_{CC} for I²C compliance. If the I²C port is unused connect this pin to INTV_{CC}, do not float.

SMBALERT (Pin 6): Open-Drain Interrupt Request. Pulls low when something important needs to be reported back to the system.

SGND (Pin 7): Signal Ground. All small signal components and compensation should connect to this ground, which should be connected to PGND at a single point.

UVCLFB (Pin 8): Undervoltage Current Limit Feedback Pin. UVCLFB can be used to reduce charge current when the V_{IN} pin reaches a level programmed by the user supplied resistor divider. This feature can be used for power sources with higher source impedance such as a solar panel. Maximum charge current is tapered off when this pin is below 1.2V, at 1.15V the charge current is zero. UVCLFB is internally clamped to about 2.5V with 200μA in this pin. Limit the current into this pin to 200μA at maximum V_{IN} using the thevenin resistance of the input divider. If the input undervoltage current limit feature is not desired, connect UVCLFB to 2P5V_{CC} through a 10k resistor or to V_{IN} through an appropriately sized resistor.

VC (Pin 9): Current Control Threshold and Error Amplifier Compensation Point. The current comparator threshold increases with this control voltage. The voltage normally ranges from 900mV to 2.4V.

RT (Pin 10): Connect a resistor from RT to GND to set frequency of the switching power supply.

NTC (Pin 11): Thermistor Input. The NTC pin connects to a negative temperature coefficient thermistor (Type_2) to monitor the temperature of the battery. The voltage on this pin is digitized by the analog to digital converter and is available via the I²C port. The thermistor value is also used to qualify battery charging. Connect a low drift bias resistor from NTCBIAS to NTC and a thermistor from NTC to ground. If NTC functions are unwanted, use a resistor equal in value to R_{NTCBIAS} instead of a thermistor.

NTCBIAS (Pin 12): NTC Thermistor Bias Output. Connect a bias resistor between NTCBIAS and NTC, and a thermistor between NTC and GND. The bias resistor should be equal in value to the nominal value of the thermistor. The LTC4015 applies 1.2V to this pin during NTC measurement.

EQ (Pin 13): Equalize. Apply a logic signal between 1.5V and INTV_{CC} (5V) to this pin to allow the 4015 to trigger lead-acid equalize mode. GND this pin if unused, do not float.

GND (Pin 14, Exposed Pad Pin 39): Ground. The exposed pad should be connected by multiple vias directly under the LTC4015 to a continuous ground plane on the second layer of the printed circuit board.

CSPM5 (Pin 15): Internal Supply Pin. The V_{CSPM5} pin regulates at the higher of ground or approximately V_{CSP} – 5V. A low impedance multilayer ceramic capacitor should be connected from V_{CSP} to V_{CSPM5}.

CCREFM (Pin 16): Coulomb Counter Reference Resistor Pin. Leakage on this pin will affect Coulomb counter accuracy. Connect a 301k, 0.1%, 25ppm resistor from CCREFM to CCREF.

CCREFP (Pin 17): Coulomb Counter Reference Resistor Pin. CCREFP in conjunction with CCREFM provide a reference for the Coulomb counter to make an accurate measure of charge into and out of the battery. CCREFP is connected internally to CSP with 50Ω. Connect a 301k, 0.1%, 25ppm resistor from CCREFP to CCREFM.

4015fb

PIN FUNCTIONS

BATSENS (Pin 18): Battery Voltage Sense Input. For proper operation, this pin must be connected physically close to the positive input terminal of the battery.

CSN (Pin 19): Connection Point for the Negative Terminal of the Charge Current Sense Resistor.

CSP (Pin 20): Connection Point for the Positive Terminal of the Charge Current Sense Resistor.

MPPT (Pin 21): MPPT Enable Pin. Apply a logic signal between 1.5V and $INTV_{CC}$ (5V) to this pin to allow the 4015 to enter MPPT mode. MPPT mode can also be entered via the I²C port. GND this pin if unused, do not float.

2P5V_{CC} (Pin 22): Bypass Pin for the Internal 2.5V Regulator. This regulator provides power to the internal logic circuitry. Bypass 2P5V_{CC} with a 2.2 μ F multilayer ceramic capacitor to GND.

SW (Pin 23): Switch Node. SW pin swings from a diode drop below ground up to V_{SYS} .

TG (Pin 24): Top Gate Drive. Drives the top N-channel MOSFET with a voltage swing equal to DRV_{CC} superimposed on the switch node voltage V_{SW} .

BOOST (Pin 25): Boosted Floating Top Gate Drive Supply. The BOOST pin swings from a diode voltage below DRV_{CC} up to $V_{SYS} + DRV_{CC}$.

BG (Pin 26): Bottom Gate Drive. Drives the bottom N-channel MOSFET between DRV_{CC} and ground.

DRV_{CC} (Pin 27): External Supply for Gate Driver. Do not exceed 5.5V on this pin. If DRV_{CC} is not connected to $INTV_{CC}$, $INTV_{CC}$ must be greater than 3V before DRV_{CC} is applied. If not connected to $INTV_{CC}$ bypass this pin to ground with a low ESR ceramic capacitor.

INTV_{CC} (Pin 28): Internal 5V Regulator Output. The control circuits and optionally the gate drivers are powered from this pin. Bypass this pin to ground with a minimum 4.7 μ F low ESR tantalum or ceramic capacitor.

OUTFET (Pin 29): Output Ideal Diode Gate Control Pin for External P-channel MOSFET.

SYSM5 (Pin 30): Internal Supply Pin. The V_{SYSM5} pin regulates at the higher of ground or approximately $V_{SYS} - 5V$. A low impedance multilayer ceramic capacitor should be connected from V_{SYS} to V_{SYSM5} .

SYS (Pin 31): System Input Voltage. Primary power input to the 4015. This pin powers the internal $INTV_{CC}$ LDO. SYS is the max of V_{BAT} or V_{IN} . V_{SYS} should be bypassed with a low impedance multilayer ceramic capacitor, along with large bulk capacitors.

CLN (Pin 32): Connection Point for the Negative Terminal of the Input Current Sense Resistor.

CLP (Pin 33): Connection Point for the Positive Terminal of the Input Current Sense Resistor.

INFET (Pin 34): Input Ideal Diode Gate Control Pin for External N-channel MOSFET.

V_{IN} (Pin 35): Supply Voltage for the PowerPath Step-down Switching Charger. V_{IN} may be connected to any suitable DC power source from 2.8V to 35V such that the voltage at V_{SYS} is high enough to allow $INTV_{CC}$ to support the desired mode of operation. In order for the telemetry system to operate $INTV_{CC}$ must exceed the telemetry undervoltage lockout. V_{IN} should be bypassed with a low impedance multilayer ceramic capacitor.

CHEM0 (Pin 36): Chemistry Select Pin. Three-state pin used in combination with CHEM1 to set the battery chemistry and charge algorithm.

CHEM1 (Pin 37): Chemistry Select Pin. Three-state pin used in combination with CHEM0 to set the battery chemistry and charge algorithm.

CELLS0 (Pin 38): Number of Cells Select Pin. Three-state pin used in combination with CELLS1 and CELLS2 to set the total number of battery cells.

BLOCK DIAGRAM

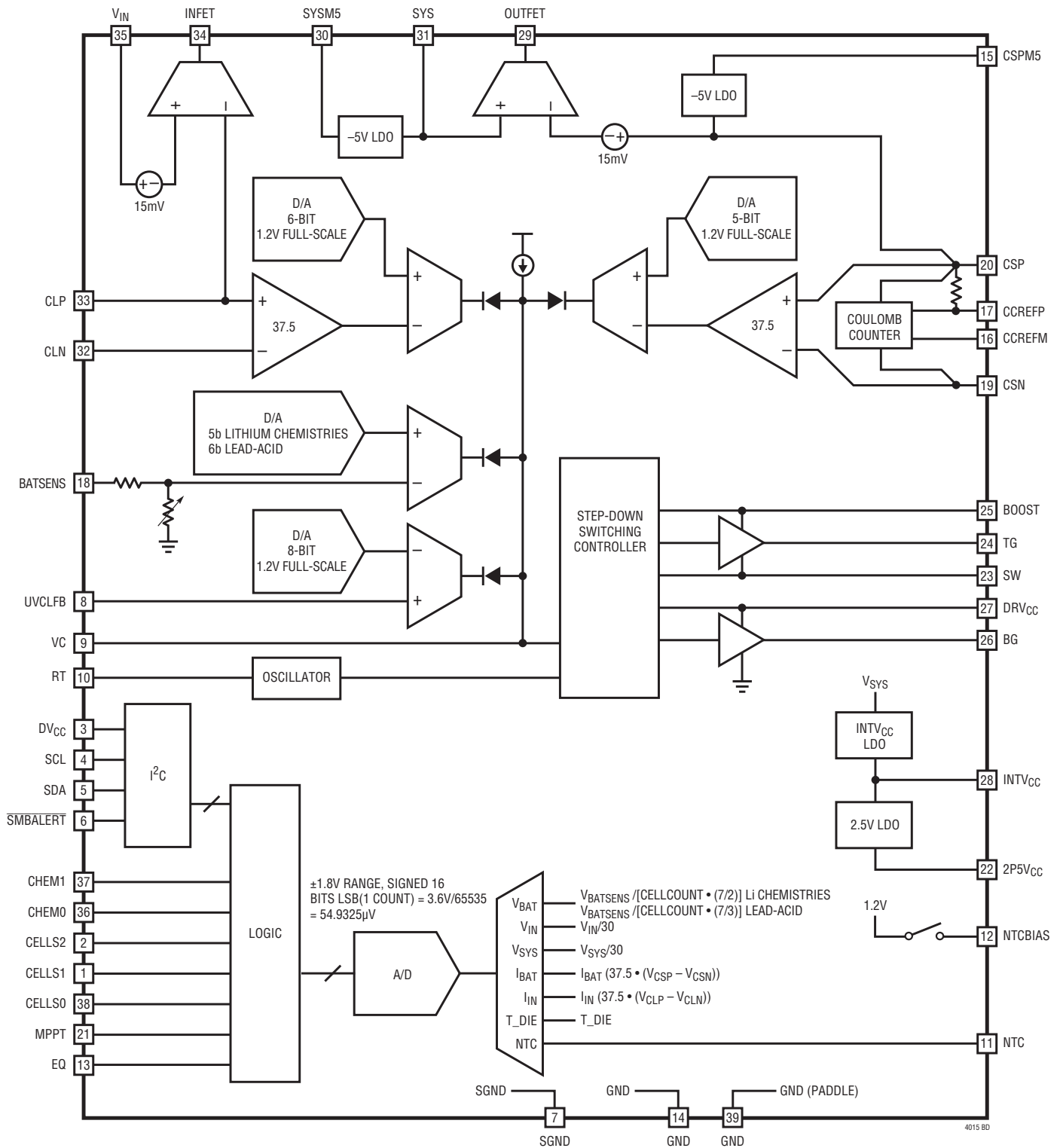

I²C TIMING DIAGRAM

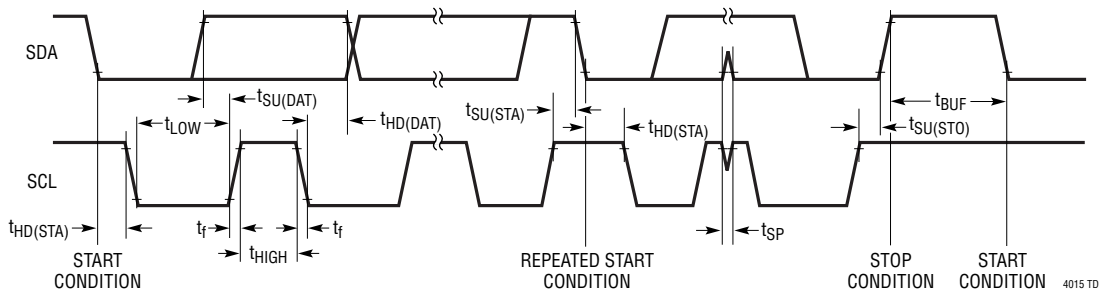

I²C SMBus Legend

- S START CONDITION
- Sr REPEATED START CONDITION
- Rd READ (BIT VALUE OF 1)
- Wr WRITE (BIT VALUE OF 0)
- A ACKNOWLEDGE
- N NACK
- P STOP CONDITION
- PEC* PACKET ERROR CODE
- MASTER TO SLAVE
- SLAVE TO MASTER

SMBus WRITE WORD PROTOCOL



SMBus WRITE WORD WITH PEC PROTOCOL



SMBus READ WORD PROTOCOL



SMBus READ WORD WITH PEC PROTOCOL



SMBus ALERT RESPONSE ADDRESS PROTOCOL



SMBus ALERT RESPONSE ADDRESS PROTOCOL WITH PEC



*USE OF PACKET ERROR CHECKING IS OPTIONAL

OPERATION

Introduction

The LTC4015 is a Li-Ion/LiFePO₄/lead-acid battery charger utilizing a step-down switching controller. It is designed to efficiently transfer power from a variety of possible sources, such as wall adapters and solar panels, to a battery and system load while minimizing power dissipation and easing thermal budgeting constraints. Since a switching regulator conserves power, the LTC4015 allows the charge current to exceed the source's output current, making maximum use of the allowable power for battery charging without exceeding the source's delivery specifications. By incorporating input voltage and current measurement and control systems, the switching charger interfaces seamlessly to these sources without requiring application software to monitor and adjust system loads.

By decoupling the system load from the battery and prioritizing power to the system, the instant-on PowerPath architecture ensures that the system is powered immediately after V_{IN} is applied, even with a completely dead battery.

Two ideal diode controllers drive external MOSFETs to provide low loss power paths from V_{IN} and V_{BAT} to the system. Two ideal diodes work with the charger to provide power from V_{BAT} to the system without back driving V_{IN} . The ideal diode from V_{BAT} to the system load guarantees that power is available to the system even if there is insufficient or absent power from V_{IN} . The ideal diode from V_{IN} to the system load guarantees neither V_{BAT} or the system will back drive V_{IN} .

A wide range of input current settings as well as battery charge current settings are available by software control and the values of sense resistors R_{SNSI} and R_{SNSB} . A measurement subsystem periodically monitors and reports system parameters via the I²C serial port. Included in this subsystem is a Coulomb counter to allow battery gas gauging.

An interrupt subsystem can be enabled to alert the host microprocessor of various status change events so that system parameters can be varied as needed by the system. Many status change events are maskable for maximum flexibility.

To eliminate battery drain between manufacture and sale, a ship-and-store feature reduces the already low battery

drain and optionally disconnects power from downstream circuitry.

The input undervoltage current loop (UVCL) can be engaged to help keep the input voltage from decreasing beyond a minimum voltage when a resistive cable or power limited supply such as a solar panel is providing input power to the LTC4015. A maximum power point algorithm using this control loop has been preprogrammed into the LTC4015 to maximize power extraction from solar panels and other resistive sources.

Finally, the LTC4015 has a digital subsystem that provides substantial adjustability so that power levels and status information can be controlled and monitored via the simple 2-wire I²C serial port.

LTC4015 Digital System Overview

The LTC4015 contains an advanced digital system which can be optionally accessed using the I²C serial port. The LTC4015 digital system can be used extensively in the application or not at all, as dictated by the application requirements. This data sheet provides extensive details of the digital functions of the LTC4015, though much of this detail is not required for simpler applications.

Use of the serial port is completely optional. Even without use of the serial port, the LTC4015 is a fully functioning high performance battery charger which is highly configurable using external components and pin connections. Chemistry/algorithm, cell count, charge current, input current regulation (ICL), V_{IN} undervoltage regulation (UVCL), maximum power point tracking (MPPT), and switching charger frequency and compensation are all externally configurable without using the serial port.

For applications requiring the LTC4015's advanced digital features, the serial port provides a means to use the Coulomb counter, read status and ADC telemetry data from the measurement system, monitor charger operation, configure charger settings (e.g. charge voltage, charge current, temperature response, etc), enable/disable/read/clear alerts, activate low power ship mode, and enable/disable the battery charger.

Detailed information about the digital system and the serial port registers, as well as digital system usage examples, can be found in the section LTC4015 Digital System.

OPERATION

Power Path Ideal Diode Controllers

The LTC4015 features input and output ideal diode controllers. These controllers make up a power path that allows power to be delivered to the system (V_{SYS}) by either V_{IN} or V_{BAT} , whichever is greater. The input ideal diode provides a one way path from V_{IN} to V_{SYS} . The output ideal diode provides a one way path from V_{BAT} to V_{SYS} .

The ideal diode controllers consist of a precision amplifier that drives the gate of a MOS transistor whenever the voltage at V_{SYS} is approximately 15mV (V_{FWD}) below the voltage at V_{IN} or V_{BAT} . Within the amplifier's linear range, the small signal resistance of the ideal diode will be quite low, keeping the forward drop near 15mV. At higher current levels, the MOS transistors will be in full conduction.

The input ideal diode controller assumes control of an external NMOS transistor by modulating the gate voltage of the NMOS transistor to allow current to flow from V_{IN} to V_{SYS} while blocking current in the opposite direction to prevent back driving V_{IN} . Additionally a fastoff comparator shuts off the NMOS if V_{IN} falls 25mV below V_{SYS} .

The output ideal diode provides a path for V_{BAT} to power V_{SYS} when V_{IN} is unavailable, while blocking current in the opposite direction to prevent overcharging of the battery. The output ideal diode controller controls an external PMOS transistor by modulating the gate voltage of the PMOS transistor. In addition to a fast-off comparator the output ideal diode also has a fast-on comparator that turns on the external MOSFET when V_{SYS} drops 45mV below V_{BAT} .

When limited power is available to the switching charger because either the programmed input current limit or input undervoltage limit is active, charge current will automatically be reduced to prioritize power delivery to the system load. Note that the LTC4015 only limits charge current, but does not limit current from the input to the system load—if the system load alone requires more power than is available from the input after charge current has been reduced to zero, V_{SYS} must fall to the battery voltage in order for the battery to provide supplemental power. Note that a system load fault can dissipate very large amounts of power, as the system load current will not be limited by the ideal diode controllers.

Input Current Regulation (ICL)

The LTC4015 contains a control loop, ICL (input current limit), that automatically reduces charge current when the overall average input current reaches a maximum level.

The input current regulation function can only reduce charge current to zero, it cannot limit the overall input current which is a function of the load on V_{SYS} .

This level is set by the combination of the current sense resistor R_{SNSI} from CLP to CLN and either the default 32mV servo voltage or a value programmed into IIN_LIMIT_SETTING via the serial port. The maximum servo voltage that can be programmed is 32mV. The voltage across the sense resistor divided by its value determines the target maximum possible input current. A 2m Ω resistor, for example, would have an upper limit of input current of 16A using a 32mV servo voltage.

Input Undervoltage Regulation (UVCL) and Solar Panel Maximum Power Point Tracking (MPPT)

The LTC4015 contains a control loop, UVCL (under voltage current limit) that allows it to tolerate a resistive connection to the input power source by automatically reducing charge current as V_{IN} (as observed at the UVCLFB pin using a V_{IN} voltage divider) drops to a programmable level (VIN_UVCL_SETTING). This circuit helps prevent UVLO oscillations by regulating the input voltage above the LTC4015's undervoltage lockout level. The UVCL function can only reduce charge current to zero, it cannot limit the overall input current which is also a function of the load on V_{SYS} .

Optionally, the LTC4015 includes a maximum power point tracking (MPPT) algorithm to find and track the VIN_UVCL_SETTING that delivers the maximum charge current to the battery. If enabled by the MPPT pin or by the mppt_en_i2c bit via the serial port, the MPPT algorithm performs a sweep of VIN_UVCL_SETTING values, measuring battery charge current at each setting. When the sweep is completed, the LTC4015 applies the VIN_UVCL_SETTING value corresponding to the maximum battery charge current (i.e. the maximum power point). The LTC4015 then tracks small changes in the maximum power point by slowly dithering the VIN_UVCL_SETTING. The LTC4015 periodically performs a new sweep of

OPERATION

VIN_UVCL_SETTING values, applies the new maximum power point, and resumes dithering at that point. With the automatic MPPT algorithm enabled, a solar panel can be used as a suitable power source for charging a battery and powering a load. The MPPT feature can be enabled either via the serial port or by connecting the MPPT pin to the 2P5V_{CC} pin or a suitable GPIO from a microcontroller.

The MPPT algorithm may not work for all solar panel applications and does not have to be used, alternatively a solar panel can be used without the MPPT algorithm by setting the UVCL V_{IN} minimum value to match the optimum loaded solar panel voltage by selecting the appropriate VIN_UVCL_SETTING and UVCLFB pin resistor divider.

Serial Port, SMBus and I²C Protocol Compatibility

The LTC4015 uses an SMBus/I²C style 2-wire serial port for programming and monitoring functions. Using the serial port, the user may program alerts, set control parameters and read status data. The timing diagram shows the relationship of the signals on the bus. The two bus lines, SDA and SCL, must be HIGH when the bus is not in use. External pull-up resistors or active loads, such as the LTC1694 SMBus accelerator, are required on these lines. The LTC4015 is both a slave receiver and slave transmitter. It is never a master. The control signals, SDA and SCL, are scaled internally to the DV_{CC} supply in compliance with the I²C specification. DV_{CC} must be connected to the same power supply as the bus pull-up resistors.

Aside from electrical levels and bus speed, the SMBus specification is generally compatible with the I²C bus specification, but extends beyond I²C to define and standardize specific protocol formats for various types of transactions. The LTC4015 serial port is compatible with the 400kHz speed and ratiometric input thresholds of the I²C specification and supports the read word and write word protocols of the SMBus specification. It has built-in timing delays to ensure correct operation when addressed from an I²C compliant master device. It also contains input filters designed to suppress glitches.

Programmable Alerts and Interrupt Controller

The serial port supports the SMBus $\overline{\text{SMBALERT}}$ protocol. An alert can optionally be generated if a monitored parameter exceeds a programmed limit or if selected bat-

tery charger states or status events occur. This offloads much of the continuous monitoring from the system's microcontroller and onto the LTC4015; reducing bus traffic and microprocessor load.

The $\overline{\text{SMBALERT}}$ pin is asserted (pulled low) whenever an enabled alert occurs (see the following tables and register descriptions). The LTC4015 will de-assert (release) the $\overline{\text{SMBALERT}}$ pin only after successfully responding to an SMB alert response address (ARA). The alert response is an SMB protocol used to respond to an $\overline{\text{SMBALERT}}$. The host reads from the alert response address 0001_1001b (0x19) and each part asserting $\overline{\text{SMBALERT}}$ begins to respond with its address. The responding parts arbitrate in such a way that only the part with the lowest address responds. Only when a part has responded with its address does it release the $\overline{\text{SMBALERT}}$ signal. If multiple parts are asserting the $\overline{\text{SMBALERT}}$ signal then multiple reads from the ARA are needed. Therefore, only a response of 1101_0001b (0xD1) will clear the LTC4015/ $\overline{\text{SMBALERT}}$ signal. Any other response indicates a device with a lower I²C address also requests attention from the host. For more information refer to the SMBus specification.

Table 1. Shows a Summary of LTC4015 Limit Alerts. Each Alert Has an Associated Enable (Mask), Limit, and Bit That Is Set to 1 to Indicate the Enabled Alert Has Occurred.

LIMIT ALERTS	ALERT ENABLE BITS (0x0D)	ALERT LIMIT SET POINT REGISTER	ALERT REPORTING BITS (0x36)
Measurement System Valid Alert (ADC Ready)	15	N/A	15
Reserved	14	N/A	N/A
Coulomb Counter Accumulator Low and High Alert	13, 12	0x10, 0x11	13, 12
Battery Voltage Low and High Alert	11, 10	0x01, 0x02	11, 10
Input Voltage Low and High Alert	9, 8	0x03, 0x04	9, 8
System Voltage Low and High Alert	7, 6	0x05, 0x06	7, 6
Input Current High Alert	5	0x07	5
Battery Current Low Alert	4	0x08	4
Die Temperature High Alert	3	0x09	3
Battery Series Resistance High Alert	2	0x0A	2
NTC Ratio High and Low Alert	1, 0	0x0B, 0x0C	1, 0

OPERATION

Table 2. Shows a Summary of LTC4015 Charger State Alerts. Each Alert Has an Associated Enable (or Mask), and Bit That Is Set to 1 to Indicate the Alert Has Occurred.

CHARGER STATE ALERTS	ALERT ENABLE BITS (0x0E)	ALERT REPORTING BITS (0x37)
Equalize	10	10
Absorb	9	9
Charger Suspended	8	8
Precharge	7	7
CC_CV	6	6
NTC Pause	5	5
Timer Termination	4	4
C/x Termination	3	3
Max Charge Time Fault	2	2
Battery Missing Fault	1	1
Battery Short Fault	0	0

Table 3. Shows a Summary of LTC4015 Charger Status Alerts. These Alerts Indicate Which Control Loop Is in Control During Charging. Each Alert Has an Associated Enable (or Mask), and Bit That Is Set to 1 to Indicate the Alert Has Occurred.

CHARGER STATUS ALERTS	ALERT ENABLE BITS (0x0F)	ALERT REPORTING BITS (0x38)
UVCL (V_{IN} Undervoltage Charge Current Limiting)	3	3
ICL (I_{IN} Charge Current Limiting)	2	2
CC (Constant-Current Mode)	1	1
CV (Constant-Voltage Mode)	0	0

Table 4. Measurement Subsystem Scaling and LSB Size

ADC LSB (3.6V/65535) =				54.932479	μV
MEASUREMENT	REGISTER SYMBOL	REGISTER NUMBER	LSB SCALING	LSB SIZE	UNITS
$V_{\text{BATSENS/Cellcount}}$ (Lithium Chemistries)	VBAT	0x3A	*7/2	192.264	μV
$V_{\text{BATSENS/Cellcount}}$ (Lead-Acid)	VBAT	0x3A	*7/3	128.176	μV
V_{IN}	VIN	0x3B	*30	1.648	mV
V_{SYS}	VSYS	0x3C	*30	1.648	mV
$V_{\text{RSNSB}} (V_{\text{CSP}} - V_{\text{CSN}})$	IBAT	0x3D	/37.5	1.465	μV
$V_{\text{RSNSI}} (V_{\text{CLP}} - V_{\text{CLN}})$	IIN	0x3E	/37.5	1.465	μV
Die Temperature (Note 1)	DIE_TEMP	0x3F	1	54.932	μV

Note 1: DIE_TEMP is the ADC conversion of a internal PTAT (proportional to absolute temperature) voltage. DIE temperature = (DIE_TEMP – 12010)/45.6 in °C.

Measurement Subsystem

The LTC4015 includes a 14-bit analog-to-digital converter (ADC) and signal channel multiplexer to monitor several analog parameters. It can measure the voltages at V_{IN} , SYS and BATSENS, the current into the SYS node (voltage across R_{SNSI}), the battery charge current (voltage across R_{SNSB}), the voltage across the battery pack thermistor, and its own internal die temperature. After a charge cycle begins the LTC4015 uses the appropriate analog parameters to calculate the series resistance of the battery. To save battery power the measurement system will not run if the battery is the only source of power, unless the force_meas_sys_on bit is set.

The converter is automatically multiplexed between all of the measured channels and its results are stored in registers accessible via the I²C port.

The seven channels measured by the ADC each take approximately 1.6ms to measure. The result of the analog-to-digital conversion is stored in a 16-bit register as a signed, two's complement number. The lower two bits of this number are sub-bits. These bits are ADC outputs which are too noisy to be reliably used on any single conversion, however, they may be included if multiple samples are averaged. The maximum range of the ADC is $\pm 1.8\text{V}$, which gives a LSB size of $3.6\text{V}/65535$ ($2^{16} - 1$).

Table 4 summarizes the LSB scaling and resultant LSB size for these ADC measurements.

OPERATION

When input power is absent, the measurement system can be sampled periodically at reduced battery load using the following procedure as an example:

- Write `en_meas_sys_valid_alert = 1`
- Write `force_meas_sys_on = 1`
- Wait for `SMBALERT` to go low (typically 20ms from `force_meas_sys_on = 1`)
- Upon `SMBALERT` going low, perform ARA command. If there are multiple slave devices, verify that the LTC4015 is asserting the alert.
- Verify `meas_sys_valid_alert = 1`
- Write `en_meas_sys_valid_alert = 0`
- Write `force_meas_sys_on = 0`
- Read updated measurement system data from the LTC4015

This procedure can be repeated at desired intervals (for example, once per second) in order to periodically monitor the system.

Thermistor/NTC Measurement

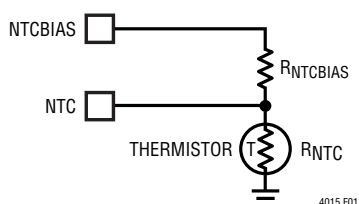

Figure 1. NTC Bias Configuration

Battery temperature is sensed by using an external NTC (negative temperature coefficient) thermistor, R_{NTC} . R_{NTC} is normally located in the battery pack. Connect R_{NTC} between the NTC pin and ground. A bias resistor, $R_{NTCCBIAS}$, is connected between NTCBIAS and NTC. $R_{NTCCBIAS}$ should be a 1% resistor with a value equal to the value of the

chosen thermistor at 25°C (r_{25}). NTC_RATIO (0x40) is available via the serial port, except when the ship mode feature has been activated.

The LTC4015 measurement system is configured to directly calculate NTC_RATIO , where:

$$NTC_RATIO = 21845 \cdot \frac{R_{NTC}}{R_{NTCCBIAS} + R_{NTC}}$$

$$R_{NTC} = R_{NTCCBIAS} \cdot \frac{NTC_RATIO}{21845 - NTC_RATIO}$$

NTC_RATIO has a bit weight of $1/21845 = 4.5777^{-5}/LSB$. For a NTC_RATIO of 0.5, where $R_{NTC} = R_{NTCCBIAS}$, the value of NTC_RATIO reported by the serial port would be approximately 10922.

The data in the first two columns in the following table are from a Vishay NTC thermistor with a R_{25} of 10k and β value of 3490k, such as provided by a Vishay NTCS0402E3103FLT or NTHS0402N02N1002JE. The NTC_RATIO value is $21845 \cdot [R_{NTC}/(R_{NTC} + R_{NTCCBIAS})]$, where $R_{NTCCBIAS} = R_{25} = 10k$.

TEMPERATURE	R_{NTC}	NTC_RATIO
10.0	18290	14122
15.0	14867	13059
20.0	12157	11985
25.0	10000	10922
30.0	8272	9889
35.0	6879	8902
40.0	5751	7975

Steps to find NTC resistor temperature given a NTC_RATIO value;

- Retrieve value for the NTC_RATIO from the LTC4015 via the I²C port
- Calculate R_{NTC} : $R_{NTC} = R_{NTCCBIAS} \cdot \frac{NTC_RATIO}{21845 - NTC_RATIO}$
- Using the calculated R_{NTC} , use NTC resistor manufacturers data to determine temperature.

OPERATION

ICL, UVCL, ICHARGE and VCHARGE DACS

The LTC4015 has four DAC's for setting target values of:

1. Maximum battery charge voltage (VCHARGE_SETTING)
2. Maximum battery charge current (ICHARGE_TARGET)
3. Minimum input voltage, UVCL (VIN_UVCL_SETTING)
4. Maximum input current (IIN_LIMIT_SETTING)

The user can program the target values only with the I²C port. The LTC4015 uses the target values as a starting point, the charging algorithms calculate the actual values to be applied to the DACs to support functions such as Li-Ion precharge, absorb and equalize charge voltage adders, MPPT, lead-acid charge voltage temperature compensation, and charger soft starting.

The target value register is read/write, the actual value register is read only. In the case of the UVCL register, minimum input voltage is scaled by external resistors. For further information see the Register Description and Battery Charging sections.

JEITA temperature controlled charging does not use VCHARGE_SETTING or ICHARGE_TARGET for setting target values, see JEITA Temperature Controlled Charging section for further information.

Charging Timers

There are a total of four timers in the LTC4015 used in the charging algorithms. Timers are 16-bit, and measure time in seconds. $2^{16} = 65535$ seconds or 18.2 hours maximum. Each timer has current value (read only) and a timeout value (read/write):

TIMED PARAMETER	CURRENT VALUE	TIMEOUT VALUE	APPLICABLE CHEMISTRIES
Constant-Voltage State Time	CV_TIMER (0x31)	MAX_CV_TIME (0x1D)	Lithium Chemistries
Maximum Total Charge Time	MAX_CHARGE_TIMER (0x30)	MAX_CHARGE_TIME (0x1E)	Lithium Chemistries
Maximum Absorb Charge Time	ABSORB_TIMER (0x32)	MAX_ABSORB_TIME (0x2B)	LiFePO4, Lead-Acid
Maximum Equalize Charge Time	EQUALIZE_TIMER (0x33)	EQUALIZE_TIME (0x2D)	Lead-Acid

Low Power Ship Mode

The LTC4015 can reduce its already low standby current to approximately 5 μ A in a special mode designed for shipment and storage. Ship mode is armed by setting the ARM_SHIP_MODE register to 0x534D (ASCII for SM) via the serial port. Note that once armed, ship mode cannot be disarmed (the ARM_SHIP_MODE register cannot be cleared once set to 0x534D). Once armed, ship mode takes

The Target and Actual Registers as Well as the DAC Size are Shown Below:

FUNCTION	TARGET VALUE REGISTER			ACTUAL VALUE REGISTER		
	NAME	HEX ADDRESS (SIZE)	DEFAULT	NAME	HEX ADDRESS (SIZE)	DEFAULT
Input Current Limit	IIN_LIMIT_SETTING	0x15(5:0)	0x3F	IIN_LIMIT_DAC	0x46(5:0)	0x3F
Battery Charge Voltage	VCHARGE_SETTING	0x1B(5:0) ¹	0x3F	VCHARGE_DAC	0x45(5:0)	0x3F
Minimum Input Voltage (UVCL)	VIN_UVCL_SETTING	0x16(8:0)	0xFF	Scaled by External Resistors		
Battery Charge Current	ICHARGE_TARGET	0x1A(4:0)	0x1F	ICHARGE_DAC	0x44(4:0)	0x1F

¹ Lithium chemistries = 5b (4:0), lead-acid chemistry = 6b (5:0)

OPERATION

Cells Selection

Number of series cells selection is made using the CELLS2, CELLS1, and CELLS0 pins. For lithium chemistries the LTC4015 allows charging of up to nine series cells. For lead-acid there are only three valid selections 3, 6 or 12 cells corresponding to 6, 12, and 24V batteries respectively. Note that number of cells multiplied by their expected maximum cell voltage during charging cannot exceed $V_{IN} - 200\text{mV}$. With V_{IN}/V_{SYS} limited to 35V as an upper bound for V_{BAT} , at nine cells the maximum V/cell would be 3.89V. In practice the 3.89V/cell will be lower, due to several factors including; input ideal diode drop ($V_{IN} - V_{SYS}$) and switcher max duty cycle. These pins should be hard wired to GND(L), INTV_{CC}(H), or left open (Z). The LTC4015 does not monitor or balance individual cells – the full battery stack voltage is divided by number of cells (V/cell) for simplicity only. The 4015 is not a substitute for pack protection!

NUMBER OF CELLS	CELLS2	CELLS1	CELLS0
Invalid	L	L	L
1	L	L	H
2	L	H	L
3	L	H	H
4	L	L	Z
5	L	Z	L
6	L	H	Z
7	L	Z	H
8	L	Z	Z
9	H	L	L
Invalid	H	L	H
Invalid	H	H	L
12*	H	H	H

* Lead-acid only

Chemistry Selection

Chemistry selection is made using the CHEM1 and CHEM0 pins. These are three-state pins used by the LTC4015 to select of one of nine chemistry specific charging algorithms. These pins should be hard wired to GND(L), INTV_{CC}(H), or left open (Z).

CHEMISTRY	CHEM1	CHEM0
Li-Ion Programmable	L	L
Li-Ion 4.2V/Cell Fixed	H	H
Li-Ion 4.1V/Cell Fixed	L	Z
Li-Ion 4V/Cell Fixed	Z	L
LiFePO ₄ Programmable	L	H
LiFePO ₄ Fixed Fast Charge	H	Z
LiFePO ₄ Fixed Standard Charge	Z	H
Lead-Acid Fixed	Z	Z
Lead-Acid Programmable	H	L

Li-Ion/LiFePO₄ Battery Charging

It is the responsibility of the user of the LTC4015 to consult with the battery manufacturer to determine the recommended charging parameters for a particular battery. Battery allowable temperature range while charging and any required charging parameter temperature coefficients also need to be considered.

OPERATION

Li-Ion/Charging Parameters

Table 5 shows Li-Ion charging parameters. For Li-Ion programmable, defaults values are shown.

Bold parameters are I²C programmable in Li-Ion programmable mode only. ICHARGE_TARGET and VCHARGE_SETTING values are at 25°C if JEITA is enabled¹. Shown in Figure 3 is an example of a Li-Ion battery charging profile. Shown in Table 6 are the Li-Ion programmable I²C configurable charging parameters.

Table 5. Li-Ion Charging Parameters

CHARGING ALGORITHM	ICHARGE_TARGET	V _{CHARGE} (PER CELL)	CV TIMER TERM ENABLE	MAX CV TIME	C/x TERM ENABLE	C/x THRESH	JEITA	MAX CHARGE TIME	LOW BAT PRECHARGE CURRENT	LOW BAT THRESHOLD (PER CELL)
Li-Ion Programmable	32mV/R_{SNSB} ¹	4.20 ¹	Yes	4 Hours	No	10%	Y	18 Hrs	~10% ²	2.9V
Li-Ion 4.2V/cell Fixed	32mV/R _{SNSB} ¹	4.20 ¹	Yes	4 Hours	No	–	Y	18 Hrs	~10% ²	2.9V
Li-Ion 4.1V/cell Fixed	32mV/R _{SNSB} ¹	4.10 ¹	Yes	4 Hours	No	–	Y	18 Hrs	~10% ²	2.9V
Li-Ion 4V/cell Fixed	32mV/R _{SNSB} ¹	4.00 ¹	Yes	4 Hours	No	–	Y	18 Hrs	~10% ²	2.9V

Table 6. Li-Ion Programmable I²C Configurable Parameters

PROGRAMMABLE MODE PARAMETER	RANGE	BITS	RESOLUTION
ICHARGE_TARGET ¹	1mV to 32mV/R _{SNSB}	5	1mV/R _{SNSB}
VCHARGE_SETTING ¹	3.8125V to 4.2V/Cell	5	12.5mV
MAX_CV_TIME	0 to 65535	16	1 Second
en_jeita	0, 1	1	1 = Enable
en_c_over_x_term	0, 1	1	1 = Enable
C_OVER_X_THRESHOLD	0mV to 32mV/R _{SNSB}	16	1.465μV/R _{SNSB}
MAX_CHARGE_TIME	0 to 65535	16	1 Second

Notes

- When JEITA is enabled (en_jeita=1), ICHARGE_TARGET and VCHARGE_SETTING are controlled by the JEITA temperature controlled charging algorithm, as described in the descriptions for ICHARGE_JEITA_n and VCHARGE_JEITA_n.
- Precharge current is 10% of ICHARGE_TARGET, rounded down to the next LSB.

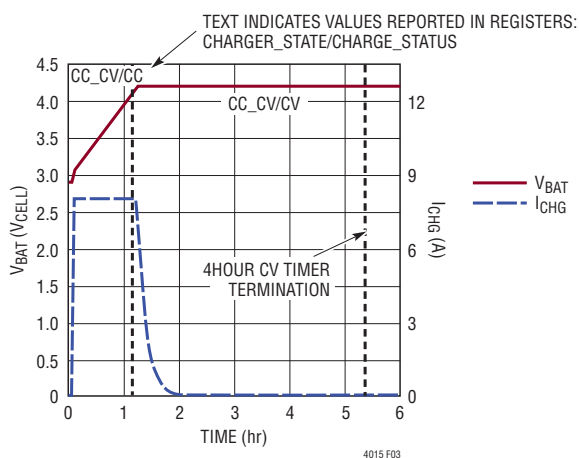

Figure 3. Li-Ion 4.2V/Cell Fixed Charging Profile

OPERATION

LiFePO₄ Charging Parameters

Table 7 shows LiFePO₄ charging parameters. For LiFePO₄ programmable, default values are shown. **Bold** parameters are I²C programmable in **LiFePO₄ programmable** mode only. ICHARGE_TARGET and VCHARGE_SETTING values

are at 25°C when JEITA is enabled. Shown in Table 8 are the **LiFePO₄ programmable** I²C configurable charging parameters. Shown in Figure 4 is the **LiFePO₄ fixed fast charge** charging profile.

Table 7. LiFePO₄ Charging Parameters

CHARGING ALGORITHM	ICHARGE_TARGET	V _{ABSORB, MAX} ABSORB TIME IN MINUTES	V _{CHARGE} (PER CELL)	CV TIMER TERM	MAX CV TIME	C/x TERM	C/x THRESH	JEITA	MAX CHARGE TIME
LiFePO ₄ Programmable	32mV/R_{SNSB} ¹	No Absorb Phase	3.60 ¹	Yes	1 Hour	No	10%	Y	18 Hrs
LiFePO ₄ Fixed Standard Charge	32mV/R _{SNSB} ¹	No Absorb Phase	3.60 ¹	Yes	1 Hour	No	–	Y	18 Hrs
LiFePO ₄ Fixed Fast Charge	32mV/R _{SNSB} ¹	3.8, 15	3.60 ¹	Yes	1 Hour	No	10% (Absorb)	Y	18 Hrs

1: When JEITA is enabled ICHARGE_TARGET and VCHARGE_SETTING are overridden and controlled by the JEITA temperature qualified charging algorithm.

Table 8. LiFePO₄ Programmable I²C Configurable Parameters

PROGRAMMABLE MODE PARAMETER	RANGE	BITS	RESOLUTION
ICHARGE_TARGET ¹	1mV to 32mV/R _{SNSB}	5	1mV/R _{SNSB}
VABSORB_DELTA	0V to 0.4V	5	12.5mV
MAX_ABSORB_TIME	0 to 65535	16	1 Second
VCHARGE_SETTING ¹	3.4125V to 3.8V/Cell	5	12.5mV
MAX_CV_TIME	0 to 65535	16	1 Second
en_jeita	0,1	1	1 = Enable
en_c_over_x_term	0,1	1	1 = Enable
C_OVER_X_THRESHOLD	0mV to 32mV/R _{SNSB}	16	1.465μV/R _{SNSB}
MAX_CHARGE_TIME	0 to 65535	16	1 Second
LiFePO ₄ _RECHARGE_THRESHOLD	0 to 4.2V/Cell	16	192.26μV

Notes

1: When JEITA is enabled ICHARGE_TARGET and VCHARGE_SETTING are overridden and controlled by the JEITA temperature qualified charging algorithm.

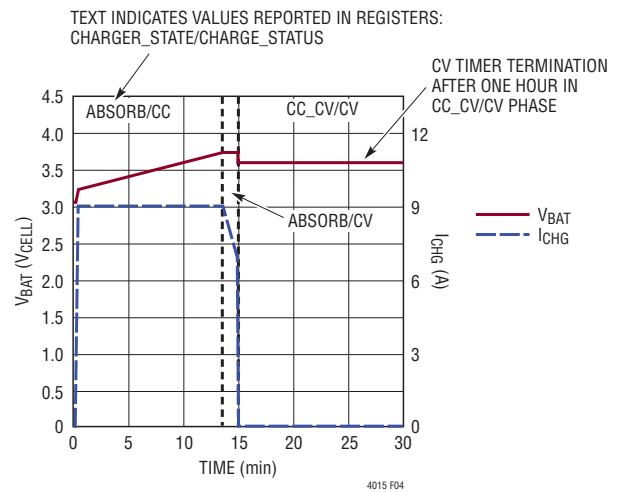

Figure 4. LiFePO₄ Fast Charge Charging Profile

OPERATION

Li-Ion/LiFePO₄ Battery Charger Operation

The LTC4015 provides full featured, inherently safe, constant-current/constant-voltage Li-Ion/LiFePO₄ battery charging. Features include battery presence detection, automatic recharge, maximum charge time safety timer, precharge (Li-Ion only), rapid absorb charge (LiFePO₄ only), programmable CV timer and C/x termination, thermistor temperature controlled charging, programmable end-of-charge indication, programmable charge voltage, programmable charge current, J.E.I.T.A. support, battery series resistance measurement, detailed status reporting, and programmable interrupt generation.

LTC4015 Charge Algorithm Overview

The LTC4015 charge algorithms are based on a constant-current constant-voltage charging (CC-CV) technique. The battery is charged at a constant-current (CC) until the battery reaches its charge voltage (V_{CHARGE}) whereupon the delivered charge current is automatically reduced to maintain the battery at a constant V_{CHARGE} (CV). The LTC4015 does not monitor or balance individual cells – the full battery stack voltage is divided by number of cells (V/cell) for simplicity only. The 4015 is not a substitute for pack protection!

Under voltage current limiting (UVCL) is used to automatically reduce charge current to help keep V_{IN} from falling below a minimum voltage. Input current limiting (ICL) is used to automatically limit charge current to help keep input current below a maximum level. However, UVCL and ICL can only reduce charge current. The total load current from V_{IN} cannot be limited by the LTC4015 if the load on the system exceeds the ICL setpoint.

Li-Ion Charge Algorithm Overview

(See Figure 5A for Li-Ion battery charging state diagram)

The charge algorithm begins with a battery detection test and proceeds to constant-current constant-voltage (CC-

CV) charging. If the Li-Ion battery voltage is very low the charger will charge at a reduced (precharge) CC rate until the battery voltage reaches an acceptable level. Then it will be charged at the full CC rate. CC-CV charging continues until the charge cycle terminates based on time (default) or battery current (C/x for Li-Ion programmable option).

LiFePO₄ Charge Algorithm (without Absorption Phase) Overview

(See Figure 5B for LiFePO₄ battery charging state diagram)

The charge algorithm begins with a battery detection test and proceeds to constant-current constant-voltage (CC-CV) charging. CC-CV charging continues until the charge cycle terminates based on time in CV mode (default) or battery current (C/x for LiFePO₄ programmable option). Remaining in constant-voltage mode without termination is also a LiFePO₄ programmable option.

LiFePO₄ Charge Algorithm (with Absorption Phase) Overview

(See Figure 5B for Li-FePO₄ battery charging state diagram)

An absorb phase can allow accelerated charging by raising the charge voltage, which may result in a higher CC rate, for a portion of the charge cycle. The charge algorithm begins with a battery detection test and proceeds to CC-CV charging with a charge voltage of V_{ABSORB} , which is an absorb delta added to V_{CHARGE} . CC-CV absorption charging continues until the V_{ABSORB} is reached and charge current has dropped below the C/x threshold, or the maximum absorb phase time has passed. Upon exiting the absorb phase the charge voltage is reduced from V_{ABSORB} to V_{CHARGE} . CC-CV charging continues until the charge cycle terminates based on time in CV mode (default) or charge current (C/x) (LiFePO₄ programmable option). Remaining in constant-voltage mode without termination is also a LiFePO₄ programmable option.

OPERATION

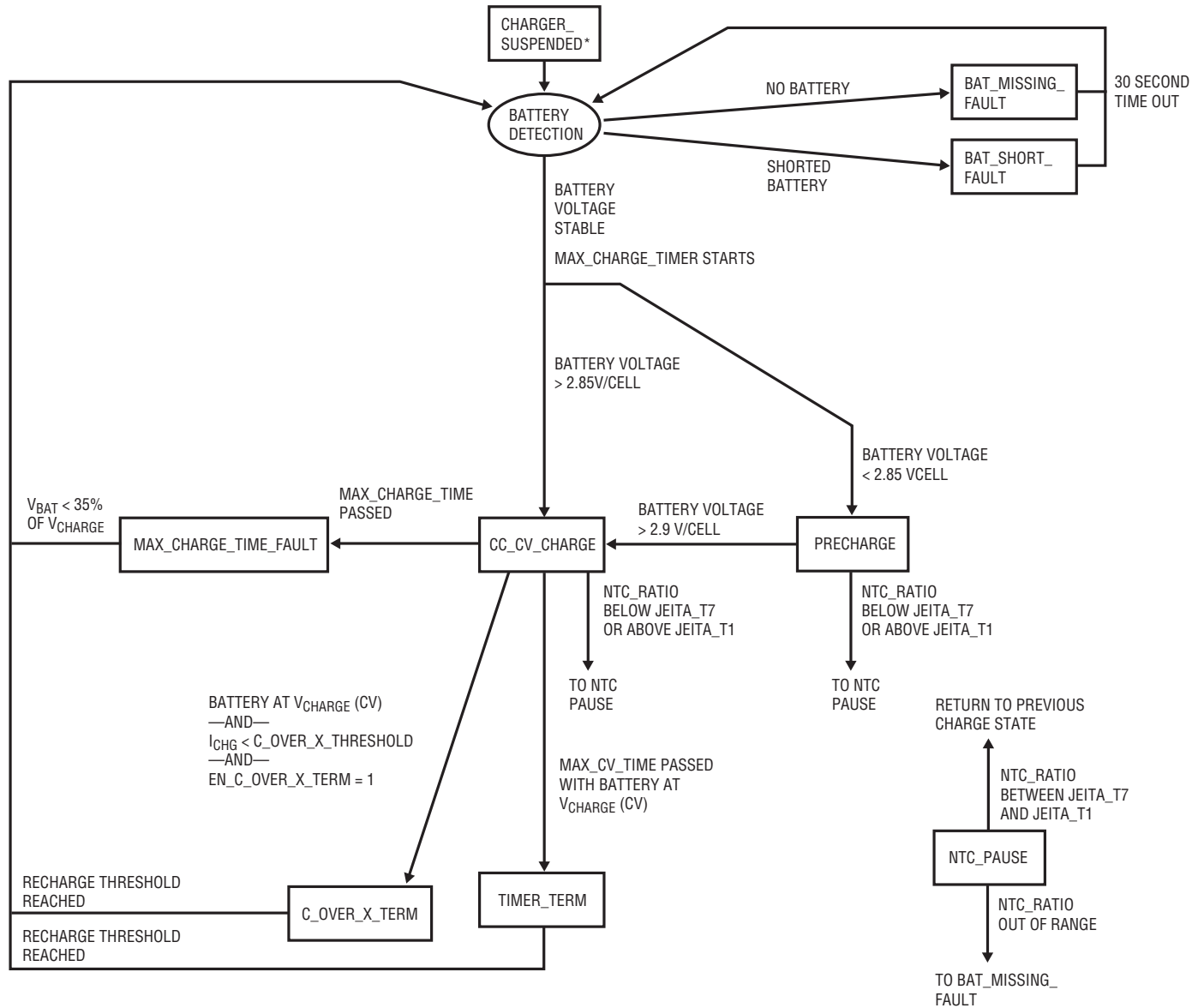

* NOTE: ALL STATES RETURN TO CHARGER SUSPENDED IF ANY OF THE FOLLOWING OCCUR:
 A. THE INPUT VOLTAGE V_{IN} FALLS TO WITHIN 100mV OF THE BATSSENS PIN VOLTAGE.
 B. SUSPEND_CHARGER IS WRITTEN TO 1 VIA THE SERIAL PORT.
 C. A SYSTEM FAULT OCCURS (V_{IN} OVERVOLTAGE LOCKOUT, 2P5V $_{CC}$ UNDERVOLTAGE LOCKOUT, INTV $_{CC}$ UNDERVOLTAGE LOCKOUT, DRV $_{CC}$ UNDERVOLTAGE LOCKOUT, THERMAL SHUTDOWN, MISSING RT RESISTOR, OR INVALID COMBINATION OF CELLS PINS).

4015 F05a

Figure 5A. Li-Ion Battery Charging State Diagram

OPERATION

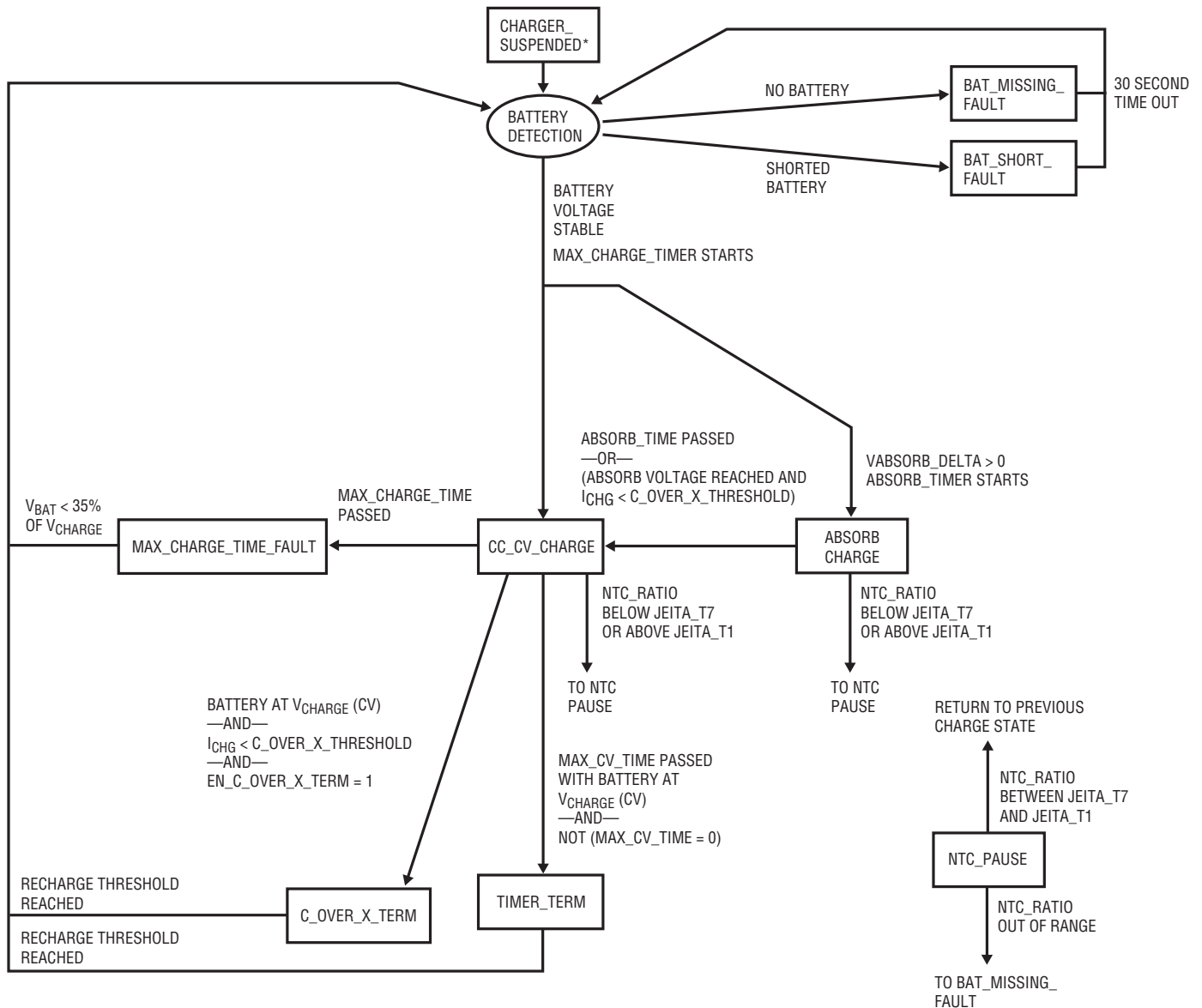

* NOTE: ALL STATES RETURN TO CHARGER SUSPENDED IF ANY OF THE FOLLOWING OCCUR:
 A. THE INPUT VOLTAGE V_{IN} FALLS TO WITHIN 100mV OF THE BATSENS PIN VOLTAGE.
 B. SUSPEND_CHARGER IS WRITTEN TO 1 VIA THE SERIAL PORT.
 C. A SYSTEM FAULT OCCURS (V_{IN} OVERVOLTAGE LOCKOUT, 2P5V_{CC} UNDERVOLTAGE LOCKOUT, INTV_{CC} UNDERVOLTAGE LOCKOUT, DRV_{CC} UNDERVOLTAGE LOCKOUT, THERMAL SHUTDOWN, MISSING RT RESISTOR, OR INVALID COMBINATION OF CELLS PINS).

4015 F05a

Figure 5B. LiFePO₄ Battery Charging State Diagram

OPERATION

Battery Detection

The LTC4015 begins a charging cycle by performing a two to four second battery detection test, during which a 1mA load is drawn from the battery. If the battery voltage remains stable during the battery detection test, the LTC4015 proceeds with battery charger soft-start. If the battery voltage does not remain stable, the LTC4015 proceeds with a battery open/short test. The battery is charged at minimum charge current for one to two seconds. If the battery voltage as a result of this brief charging is within a reasonable range the LTC4015 will proceed with a battery charger soft-start. A battery open fault will also occur if the NTC resistor is open or has a very high value. A programmable interrupt can be set to alert the system if a battery detection fault has occurred.

Battery Charger Soft-Start

The LTC4015 soft starts by ramping ICHARGE_DAC from 0 to ICHARGE_TARGET at a nominal rate of 400 μ s per ICHARGE_TARGET LSB. This results in a maximum soft-start time of $31 \cdot 400\mu\text{s} = 12.4\text{ms}$.

Maximum Charge Time

The LTC4015, for charging batteries of Lithium chemistries, provides a maximum charge time safety timer. The MAX_CHARGE_TIMER starts with the battery charger soft-start after battery detection. If the total time charging the battery exceeds MAX_CHARGE_TIME, the charger will enter the MAX_CHARGE_TIME FAULT state and cease charging. This fault state can only be exited in normal operation if the battery voltage is less than 35% of V_{CHARGE} , where upon a new charge cycle begins and the timer reset. The timer is reset upon timer or C/x termination. The MAX_CHARGE_TIME fault state can also be exited as a result of the input voltage V_{IN} falling to within 100mV of the BATSENS pin voltage, SUSPEND_CHARGER is written to a 1 via the serial port or a system fault occurs.

Low Battery/Pre-Charge; Li-Ion

When a Li-Ion battery charge cycle begins, the LTC4015 first determines if the battery is deeply discharged. If the battery voltage is below 2.85V per cell (VBAT_FILT below 14822) and BATSENS pin is above 2.6V then the LTC4015 begins charging by applying a preconditioning charge equal to ICHARGE_TARGET/10 (rounded down to the next LSB), and reporting precharge = 1. When the battery voltage exceeds 2.9V per cell (VBAT_FILT above 15082), the LTC4015 proceeds to the constant-current/constant-voltage charging phase (cc_cv_charge = 1).

Should the BATSENS pin voltage be lower than 2.4V, the switching charger operates in constant peak current mode, where the peak current is 7mV/ R_{SNSB} . Exact average current value depends on a number of factors including input voltage, battery voltage and inductance value. When the BATSENS pin voltage is higher than 2.6V, normal charging proceeds.

Low Battery; LiFePO₄

Low battery for LiFePO₄ chemistry is the same as Li-Ion with the exception that there is no preconditioning charge phase; charge current is set by ICHARGE_TARGET.

However, if the BATSENS pin voltage is lower than 2.4V, the switching charger operates in constant peak current mode, where the peak current is 7mV/ R_{SNSB} . Exact average current value depends on a number of factors including input voltage, battery voltage and inductance value. When the BATSENS pin voltage is higher than 2.6V, normal charging proceeds.

LiFePO₄ Absorb Charge

The LTC4015 can optionally perform an accelerated absorb charge cycle on LiFePO₄ batteries. If VABSORB_DELTA is greater than zero, the LTC4015 begins charging with an absorb charge phase, and reports absorb_charge = 1

OPERATION

via the serial port. During absorb charging, the LTC4015 charges at a constant-current I_{CHG} , with a target set by `ICHARGE_TARGET` and R_{SNSB} , unless one of the following conditions occurs:

- The battery voltage reaches the absorb target voltage (determined by `VCHARGE_SETTING + VABSORB_DELTA`, limited to a maximum of 3.8V/cell), indicated by `constant_voltage=1`
- Input current limit (`IIN_LIMIT_SETTING`) is reached, indicated by `iin_limit_active=1`
- The UVCLFB pin voltage falls to the undervoltage current limit (`VIN_UVCL_SETTING`), indicated by `vin_uvcl_active=1`

If either the input current limit or the undervoltage current limit is activated, the LTC4015 will limit charge current and will attempt to regulate at the input current or input voltage limit level, as permitted by the input source and system load.

LiFePO₄ Absorb Phase Ends After Either:

- `MAX_ABSORB_TIME` has passed
- The battery voltage reaches absorb target voltage (as determined by `VCHARGE_SETTING+VABSORB_DELTA`, limited to a maximum of 3.8V/cell), indicated by `constant_voltage=1`, and `IBAT` falls below `C_OVER_X_THRESHOLD`. When the absorb phase ends, the LTC4015 proceeds to the CC-CV charging phase.

Constant-Current/Constant-Voltage (CC-CV) Charging Constant-Current

When the battery voltage is above 2.9V per cell, the charger will attempt to deliver the programmed charge current I_{CHG} , as set by `ICHARGE_TARGET` and R_{SNSB} , in constant-current mode. Depending on available input power and external load conditions, the battery charger may not be able to charge at the full programmed rate. If input current limit is reached, the system load will always be prioritized over the battery charge current. Likewise, the

input undervoltage control loop will always be observed and may limit the power available to charge the battery. When system loads permit, battery charge current will be maximized.

The upper limit of charge current I_{CHG} is programmed by the combination of the current sense resistor (R_{SNSB}) from CSP to CSN and a servo voltage of 32mV or a value programmed via the serial port (see register descriptions for `ICHARGE_TARGET` and `icharge_jeita_n`). The voltage across R_{SNSB} divided by its value determines the maximum possible charge current. The maximum servo voltage that can be programmed is 32mV. A 4m Ω resistor, for example, would have an upper limit charge current of 8A.

Independent of whether or not the charge current loop is controlling the switching charger, the voltage across the R_{SNSB} will represent the actual charge current delivered to the battery. The voltage across R_{SNSB} is measured by the LTC4015's onboard measurement system and is available via the serial port in register `IBAT`.

R_{SNSB} should be set based on the maximum charge current of the battery without regard to source or load limitations from any other control loop. The multiple control loop architecture of the LTC4015 will correct for any discrepancies, always sorting out the optimal transfer of power to the battery.

Battery Series Resistance (BSR) Measurement

The LTC4015 can optionally measure the series resistance of the battery. If `run_bsr` is set to 1 the LTC4015 momentarily suspends the battery charger and calculates the battery series resistance by dividing the change (charging vs charger suspended) in battery voltage by the change in charge current (`ICHARGE_BSR`). The per cell resistance value is reported in the `BSR` register and the change in charge current is reported in the `ICHARGE_BSR` register via the serial port. The LTC4015 resets `run_bsr` to 0 after the BSR measurement is complete. The battery series resistance value is proportional to the charge current

OPERATION

sense resistor, R_{SNSB} , and can be computed in Ω from $BSR \cdot R_{SNSB}/500$. Note that the resistance reported in the BSR register must be multiplied by the total number of cells to calculate total battery series resistance. The higher ICHARGE_BSR (charge current) when a BSR measurement is requested, the more accurate the BSR measurement will be. Very low values of ICHARGE_BSR may significantly impact the accuracy of the BSR measurement. Setting run_bsr to a 1 will not turn the charger on, if the charger is suspended or in a termination state, setting run_bsr = 1 results in the BSR measurement request being queued and run after the soft-start of the next charge cycle.

Battery Charge Voltage Regulation, Constant-Voltage

Once the BATSENS voltage reaches the preset charge voltage, the switching charger will reduce its output power, holding the battery voltage steady. The charge current will decrease naturally toward zero providing inherently safe operation by preventing the battery from being over-charged. Multiple charge voltage settings are available for final charge voltage selection via the serial port. While charge voltage trade-offs can be made to preserve battery life or maximize capacity, it is not possible for the LTC4015 to be set to a charge voltage that is dangerously high or inconsistent with the battery's chemistry.

Li-Ion LiFePO₄ Full Capacity Charge Indication (C/x) and Charger Termination

The battery charge cycle will terminate at the expiration of a built-in programmable CV termination safety timer (CV_TIMER). When the voltage on the battery reaches the programmed charge voltage, the safety timer is started. After the safety timer expires, charging of the battery will discontinue and no more current will be delivered. The safety timer's default expiration time may be altered via the serial port. For Li-Ion cells the timer termination feature cannot be disabled. For LiFePO₄ cells, timer termination can be disabled by setting MAX_CV_TIME to zero, in this case, if C/x termination is not enabled, charging will not terminate. C/x termination cannot be enabled in fixed chemistry algorithms.

In addition, by monitoring the charge current and other states of the system, the LTC4015 determines when the battery has reached a given state of charge. Specifically, programmable C/x detection in constant-voltage mode determines when the charge current has naturally dropped to a given fraction of its full-scale current. If C/x termination is enabled the charge cycle will end when C/x is reached, or when then safety timer expires, whichever occurs first. C/x termination is disabled by default. The LTC4015 can optionally be configured via the serial port to generate an interrupt and terminate charging when the C/x threshold is reached.

The LTC4015 terminates charging by disabling the switching controller, when this occurs the SW node goes HI Z.

Li-Ion LiFePO₄ Automatic Recharge

After the battery charger terminates, it will remain off, drawing only a small amount of current from the battery. If the portable product remains in this state long enough, the battery will eventually self discharge. To ensure that the battery is always topped off, a new charge cycle will automatically begin when the battery voltage falls below approximately 97.5% of the programmed charge voltage for Li-Ion and 3.35V/cell for LiFePO₄ (3.35V/cell is the default for LiFePO₄_RECHARGE_THRESHOLD in LiFePO₄ programmable mode). The termination safety timer will also reset back to zero. A new charge cycle will also be initiated if input power is cycled or if the charger is momentarily disabled using the serial port (suspend_charger set to 1, then set to 0).

J.E.I.T.A. Temperature Controlled Charging

For lithium chemistries, a measurement and control system has been included to enable compliance with the Japan Electronics and Information Technology Industries Association guidelines on battery charging. Specifically a very flexible multi-point temperature-voltage-current

OPERATION

profile can be programmed into the LTC4015 to ensure that optimum charging parameters as a function of temperature are always used. Figure 6 illustrates an example of the JEITA system available in the LTC4015. There are seven distinct temperature regions programmed by the six temperature set points JEITA_T1-JEITA_T6. For each of the temperature regions, the charge current and charge voltage can be programmed within the limits set by $V_{CSP-CSN}/R_{SNSB}$ (I_{CHARGE}) and battery charge voltage (V_{CHARGE}) for a selected chemistry code.

When JEITA is enabled, charge current is controlled by I_{CHARGE_DAC} , which in turn is set by $icharge_jeita_n$ of the applicable JEITA region. Writing I_{CHARGE_TARGET} has no effect, as it will be overwritten by JEITA. Likewise V_{CHARGE} is controlled by V_{CHARGE_DAC} which in turn is set by $vcharge_jeita_n$ of the applicable JEITA region.

The LTC4015 provides temperature controlled charging if a grounded thermistor and a bias resistor are connected to the NTCBIAS and NTC pins. Charging is paused if the temperature rises above a programmable upper limit or falls below a programmable lower limit.

If the application does not require temperature controlled charging then the thermistor should be replaced with a resistor of equal value to bias resistor $R_{NTCBIAS}$, for example, 10k Ω .

The values for the JEITA registers are shown in the tables below. The **bold** values in the tables are programmable when using Li-Ion programmable or LiFePO₄ programmable chemistry selections.

The JEITA_Tn registers determine the NTC_RATIO values for the breakpoints between regions. The corresponding temperature values assume a thermistor β value of 3490k, such as provided by a Vishay NTCS0402E3103FLT or NTHS0402N02N1002JE. For other thermistors, one or two inexpensive low temperature coefficient resistors can generally be added to the circuit to adjust the thermistor's biasing (see the section NTC Resistor in Applications Information for details).

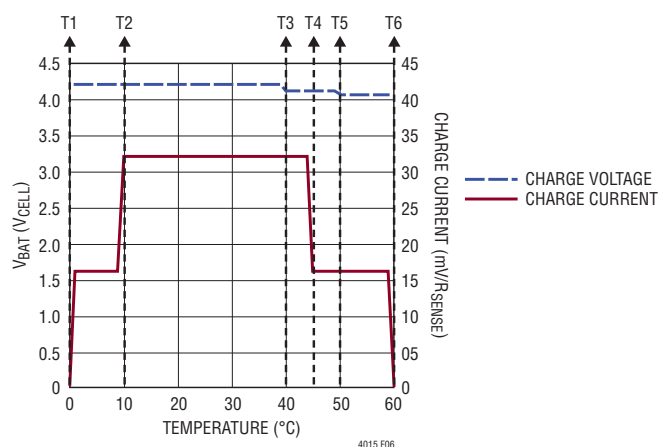

Figure 6. Default JEITA Temperature Profile, Showing Values for Li-Ion Fixed 4.2V

Table Illustrates the JEITA Values That Can Be Programmed Via the Serial Port.

REGION 1	REGION 2	REGION 3	REGION 4	REGION 5	REGION 6	REGION 7
	JEITA_T1	JEITA_T2	JEITA_T3	JEITA_T4	JEITA_T5	JEITA_T6
CHARGER	$icharge_jeita_2$	$icharge_jeita_3$	$icharge_jeita_4$	$icharge_jeita_5$	$icharge_jeita_6$	CHARGER
OFF	$vcharge_jeita_2$	$vcharge_jeita_3$	$vcharge_jeita_4$	$vcharge_jeita_5$	$vcharge_jeita_6$	OFF

OPERATION

Table Default Values for JEITA Parameters

REGION 1	REGION 2	REGION 3	REGION 4	REGION 5	REGION 6	REGION 7
	JEITA_T1 = 0x3F00 (0°C)	JEITA_T2 = 0x372A (10°C)	JEITA_T3 = 0x1F27 (40°C)	JEITA_T4 = 0x1BCC (45°C)	JEITA_T5 = 0x18B9 (50°C)	JEITA_T6 = 0x136D (60°C)
CHARGER OFF	icharge_jeita_2 vcharge_jeita_2	icharge_jeita_3 vcharge_jeita_3	icharge_jeita_4 vcharge_jeita_4	icharge_jeita_5 vcharge_jeita_5	icharge_jeita_6 vcharge_jeita_6	CHARGER OFF
Li-Ion Programmable						
CHARGER OFF	16mV/R_{SNSB} 4.20V	32mV/R_{SNSB} 4.20V	32mV/R_{SNSB} 4.10V	16mV/R_{SNSB} 4.10V	16mV/R_{SNSB} 4.05V	CHARGER OFF
Li-Ion Fixed 4.2V						
CHARGER OFF	16mV/R _{SNSB} 4.20V	32mV/R _{SNSB} 4.20V	32mV/R _{SNSB} 4.10V	16mV/R _{SNSB} 4.10V	16mV/R _{SNSB} 4.05V	CHARGER OFF
Li-Ion Fixed 4.1V						
CHARGER OFF	16mV/R _{SNSB} 4.10V	32mV/R _{SNSB} 4.10V	32mV/R _{SNSB} 4.00V	16mV/R _{SNSB} 4.00V	16mV/R _{SNSB} 3.95V	CHARGER OFF
Li-Ion Fixed 4.0V						
CHARGER OFF	16mV/R _{SNSB} 4.00V	32mV/R _{SNSB} 4.00V	32mV/R _{SNSB} 3.90V	16mV/R _{SNSB} 3.90V	16mV/R _{SNSB} 3.85V	CHARGER OFF
LiFePO₄ Programmable						
CHARGER OFF	16mV/R_{SNSB} 3.60V	32mV/R_{SNSB} 3.60V	32mV/R_{SNSB} 3.50V	16mV/R_{SNSB} 3.50V	16mV/R_{SNSB} 3.45V	CHARGER OFF
LiFePO₄ Fixed Fast and Fixed Standard Charge						
CHARGER OFF	16mV/R _{SNSB} 3.60V	32mV/R _{SNSB} 3.60V	32mV/R _{SNSB} 3.50V	16mV/R _{SNSB} 3.50V	16mV/R _{SNSB} 3.45V	CHARGER OFF

Lead-Acid Battery Charging

It is the responsibility of the user of the LTC4015 to consult with the battery manufacturer to determine the recommended charging parameters for a particular battery. Battery allowable temperature range while charging and any required charging parameter temperature coefficients also need to be considered.

An example of charging profile (battery voltage and current vs. time) for a lead-acid battery is shown in Figure 7.

Lead-Acid Charging Parameters

Following is a table of lead-acid charging parameters. For lead-acid programmable, default values are shown. **Bold** parameters are programmable via the serial port in lead-acid programmable mode only. All voltages are per cell at 25°C.

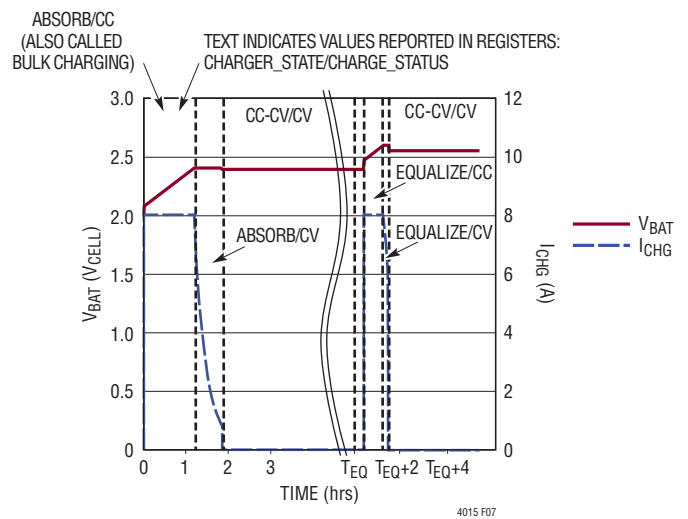

Figure 7. Example Charging Profile for a Lead-Acid Battery

OPERATION

PROGRAMMABLE MODE PARAMETER	RANGE	BITS	RESOLUTION
ICHARGE_TARGET	1mV to 32mV/ R _{SNSB}	5	1mV/R _{SNSB}
VCHARGE_SETTING	2V to 2.6V/Cell	6	9.523mV
VABSORB_DELTA	0V to 0.6V/Cell	6	9.523mV
VEQUALIZE_DELTA	0V to 0.6V/Cell	6	9.523mV
MAX_ABSORB_TIME	0 to 65535	16	1 Second
EQUALIZE_TIME	0 to 65535	16	1 Second
en_lead_acid_temp_comp	0, 1	1	1 = Enable
C_OVER_X_THRESHOLD ¹	0mV to 32mV/ R _{SNSB}	16	1.465μV/ R _{SNSB}

Notes

1: In lead-acid mode C_OVER_X_THRESHOLD is used only to terminate the absorb charge phase.

Lead-Acid Battery Charger Operation

The LTC4015 provides full featured, inherently safe, constant-current/constant-voltage lead-acid battery charging with battery presence detection, equalization, absorb, bad battery detection, thermistor based charge voltage temperature compensation, programmable charge voltage, programmable charge current, battery series resistance measurement, detailed status reporting, and programmable interrupt generation.

LTC4015 Charge Algorithm Overview

The LTC4015 charge algorithms are based on a constant-current constant-voltage charging (CC-CV) technique. The battery is charged at a constant-current (CC) until the battery reaches its charge voltage (V_{CHARGE}) whereupon the delivered charge current is automatically reduced to maintain the battery at a constant V_{CHARGE} (CV). The LTC4015 does not monitor or balance individual cells – the full battery stack voltage is divided by number of cells (V/cell) for simplicity only. The 4015 is not a substitute for pack protection!

Lead-Acid Charging Parameters

CHARGING ALGORITHM	ICHARGE_TARGET	ABSORB C_OVER_X_THRESHOLD	VEQUALIZE, EQUALIZE TIME (MINUTES)	VABSORB, MAX ABSORB TIME (MINUTES)	END ABSORB ON C/x	VCHARGE (PER CELL)	mV/C TEMPCO	TEMPCO ENABLED
Lead-Acid Fixed	32mV/R _{SNSB}	3.2mV/R _{SNSB}	2.60, 60	2.40, 90	Yes	2.20	-3.65	Yes
Lead-Acid Programmable	32mV/R_{SNSB}	3.2mV/R_{SNSB}	2.60, 60	2.40, 90	Yes	2.20	-3.65	Yes

Undervoltage current limiting (UVCL) is used to automatically reduce charge current to help keep V_{IN} from falling below a minimum voltage. Input current limiting (ICL) is used to automatically limit charge current to help keep input current below a maximum level. However, UVCL and ICL can only reduce charge current. The total load current from V_{IN} cannot be limited by the LTC4015 if the load on SYS exceeds the ICL setpoint.

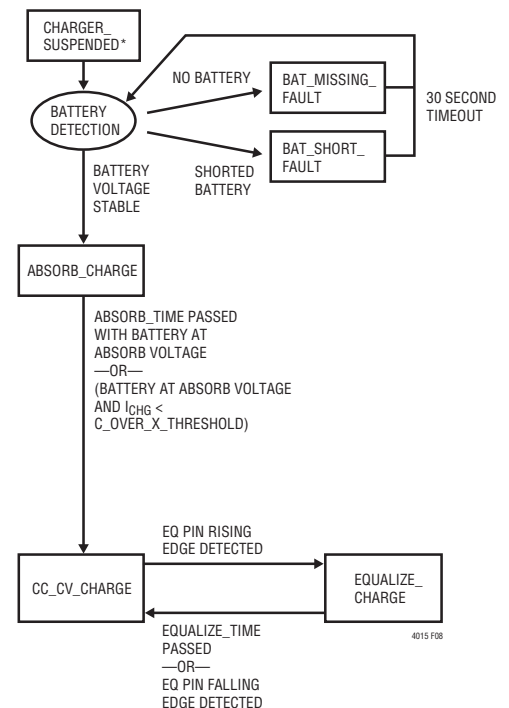

* NOTE: ALL STATES RETURN TO CHARGER SUSPENDED IF ANY OF THE FOLLOWING OCCUR:
 A. THE INPUT VOLTAGE V_{IN} FALLS TO WITHIN 100mV OF THE BATSNS PIN VOLTAGE.
 B. SUSPEND_CHARGER IS WRITTEN TO 1 VIA THE SERIAL PORT.
 C. A SYSTEM FAULT OCCURS (V_{IN} OVERVOLTAGE LOCKOUT, 2P5V_{CC} UNDERVOLTAGE LOCKOUT, INTV_{CC} UNDERVOLTAGE LOCKOUT, DRV_{CC} UNDERVOLTAGE LOCKOUT, THERMAL SHUTDOWN, MISSING R_T RESISTOR, OR INVALID COMBINATION OF CELLS PINS).

Figure 8. Lead-Acid Battery Charging State Diagram

Lead Acid Charge Algorithm Overview

(See Figure 8 for lead-acid battery charging state diagram)

The charge algorithm begins with a battery detection test, then proceeds to CC-CV charging with a charge voltage

OPERATION

of V_{ABSORB} , which is an absorb delta added to V_{CHARGE} . Following constant-current bulk charging, constant-voltage absorption charging continues until V_{ABSORB} is reached and charge current has dropped below the C/x threshold, or the battery absorb charge voltage is reached and the maximum absorb phase time has passed. If neither of the criteria for exiting the absorb charge phase is met then CC-CV charging with V_{ABSORB} charge voltage can continue indefinitely. Upon exiting the absorb phase the charge voltage absorb delta is set to zero and CC-CV float charging continues indefinitely.

Upon exiting the absorb phase an equalization charge can be performed upon user request.

Lead Acid Equalization Charge

The equalization charge voltage, V_{EQUALIZE} , can be significantly higher than the absorption voltage. This aggressive overcharging of the battery can equalize acid concentrations throughout the battery and remove electrode sulfation that may have formed during low charge conditions. Equalization can restore battery capacity, but it can also result in battery heating, overcharging of some or all cells and the loss of electrolyte which can lead to battery damage. Equalization is typically not performed with sealed batteries because they are usually not re-wettable in the event of electrolyte loss. Due to its aggressive nature, specific equalization frequency, voltage and time duration should be obtained from the battery manufacturer.

Battery Detection

The LTC4015 begins a charging cycle by performing a two to four second battery detection test, during which a 1mA load is drawn from the battery. If the battery voltage remains stable during the battery detection test, the LTC4015 proceeds with battery charger soft-start. If the battery voltage does not remain stable, the LTC4015 proceeds with a battery open/short test. The battery is charged at minimum charge current for one to two seconds. If the battery voltage as a result of this brief charging is within a reasonable range the LTC4015 will proceed with a battery charger soft-start. A battery open fault will also occur if the NTC resistor is open or has a very high value. A programmable interrupt can be set to alert the system if a battery detection fault has occurred.

Battery Charger Soft-Start

The LTC4015 soft-starts by ramping ICHARGE_DAC from minimum to ICHARGE_TARGET at a nominal rate of 400 μ S per ICHARGE_TARGET LSB. This results in a maximum soft-start time of $31 \cdot 400\mu\text{S} = 12.4\text{mS}$.

Low Battery

If the BATSENS pin voltage is lower than 2.4V, the switching charger operates in constant peak current mode, where the peak current is $7\text{mV}/R_{\text{SNSB}}$. Exact average current value depends on a number of factors including input voltage, battery voltage and inductance value. When the BATSENS pin voltage is higher than 2.6V, normal charging proceeds.

Absorb Charge

The LTC4015 begins lead-acid battery charging with an absorb charge phase, and reports absorb_charge = 1 via the serial port. During absorb charging, the LTC4015 charges at a constant-current I_{CHG} , with a target set by ICHARGE_TARGET and R_{SNSB} , unless one of the following conditions occurs:

- The battery voltage reaches the absorb target voltage (V_{ABSORB}) (determined by $V_{\text{CHARGE_SETTING}} + V_{\text{ABSORB_DELTA}}$, limited to a maximum of 2.6V/cell), indicated by constant_voltage=1
- Input current limit (IIN_LIMIT_SETTING) is reached, indicated by iin_limit_active=1
- The UVCLFB pin voltage falls to the undervoltage current limit ($V_{\text{IN_UVCL_SETTING}}$), indicated by vin_uvcl_active=1

If either the input current limit or the input undervoltage current limit is activated, the LTC4015 will limit charge current and will attempt to regulate at the input current limit or input undervoltage limit, as permitted by the input source and system load.

Absorb phase ends after the battery voltage reaches V_{ABSORB} and either ABSORB_TIMER reaches MAX_ABSORB_TIME or IBAT falls below C_OVER_X_THRESHOLD. When the absorb phase ends, the LTC4015 proceeds to constant-current/constant-voltage (CC-CV) charge phase.

Constant-Current/Constant-Voltage (CC-CV) Charge:

In CC-CV charging phase, the LTC4015 prevents the

OPERATION

battery voltage from falling below the charge voltage level, as determined by VCHARGE_SETTING, unless one of the following conditions occurs:

- The battery charge current I_{CHG} reaches the target set by ICHARGE_TARGET, indicated by constant_current=1
- Input current limit (IIN_LIMIT_SETTING) is reached, indicated by iin_limit_active=1
- The UVCLFB pin voltage falls to the undervoltage current limit (VIN_UVCL_SETTING), indicated by vin_uvcl_active = 1

If either the input current limit or the input undervoltage current limit is activated, the LTC4015 will limit charge current and will attempt to regulate at the input current limit or input undervoltage limit, as permitted by the input source and system load. There is no termination in the charging algorithm for lead-acid; the charger will remain in CV mode as long as input power is available.

Equalization Charge:

If a rising edge is detected on the EQ pin (as reported by the equalize_req bit), the LTC4015 will perform an equalization charge when the charge voltage is reached (constant-voltage = 1) in constant-current/constant-voltage (CC-CV) charge phase. In equalization charging phase, the LTC4015 charges the battery at a constant-current I_{CHG} , with a target set by ICHARGE_TARGET and R_{SNSB} , unless one of the following conditions occurs:

- The battery voltage reaches the equalization target voltage (as determined by VCHARGE_SETTING+VEQUALIZE_DELTA, limited to a maximum of 2.6V/cell), indicated by constant_voltage=1,
- Input current limit (IIN_LIMIT_SETTING) is reached, indicated by iin_limit_active=1, or
- The UVCLFB pin voltage falls to the undervoltage current limit (VIN_UVCL_SETTING), indicated by vin_uvcl_active=1.

If either the input current limit or the input undervoltage current limit is activated, the LTC4015 will limit charge current and will attempt to regulate at the input current limit or input undervoltage limit, as permitted by the input source and system load. Equalize charge phase runs until EQUALIZE_TIMER reaches EQUALIZE_TIME, at which time

the LTC4015 returns to constant-current/constant-voltage (CC-CV) charge phase.

The EQ pin is rising edge triggered, it must remain high through the duration of the equalize phase. The EQ pin must be de-asserted and re-asserted to begin another equalization charge.

V_{IN} Input Power Removal/SUSPEND_CHARGER/ System Fault Response

If, at any time, the input voltage on the V_{IN} pin falls to within 100mV of the BATSENS pin voltage, or suspend_charger is written to 1 via the serial port, or if a system fault condition occurs (V_{IN} overvoltage, low 2P5V_{CC} voltage, low INTV_{CC} voltage, low DRV_{CC} voltage, thermal shutdown, missing R_T resistor, or invalid combination of CELLS pins), the LTC4015 suspends charging and reports charger_suspended = 1.

Battery Series Resistance (BSR) Measurement

The LTC4015 can optionally measure the series resistance of the battery. If run_bsr is set to 1 the LTC4015 momentarily suspends the battery charger and calculates the battery series resistance. The per cell resistance value is reported in the BSR register and the change in charge current is reported in the ICHARGE_BSR register via the serial port. The battery series resistance value is proportional to the charge current sense resistor, R_{SNSB} , and can be computed in Ω from $BSR \times R_{SNSB} / 750$. Note that the resistance reported in the BSR register must be multiplied by the total number of cells to calculate total battery series resistance. The higher ICHARGE_BSR (charge current) when a BSR measurement is requested, the more accurate the BSR measurement will be. Very low values of ICHARGE_BSR may significantly impact the accuracy of the BSR measurement. Setting run_bsr to a 1 will not turn the charger on, if the charger is suspended or in a termination state. Setting run_bsr = 1 results in the BSR measurement request being queued and run after the soft-start of the next charge cycle.

Lead-Acid Temperature Compensated Charging (en_lead_acid_temp_comp=1)

The LTC4015 uses a $-3.65 \text{ mV}/^\circ\text{C}$ per cell V_{CHARGE} temperature compensation when using a thermistor with a β value of 3490K similar to a Vishay NTCS0402E3103FLT or NTHS0402N02N1002JE thermistor. When en_lead_

OPERATION

acid_temp_comp=1, the registers VCHARGE_SETTING, VABSORB_DELTA, and VEQUALIZE_DELTA control the 25°C value of VCHARGE_DAC. At other temperatures, the value of VCHARGE_DAC is adjusted based on NTC_RATIO, to produce the temperature profile shown in Figure 9. In effect, the temperature profile is shifted up or down by increasing or decreasing the values of VCHARGE_SETTING, VABSORB_DELTA, and VEQUALIZE_DELTA, but the slope of the temperature compensation response is not directly programmable.

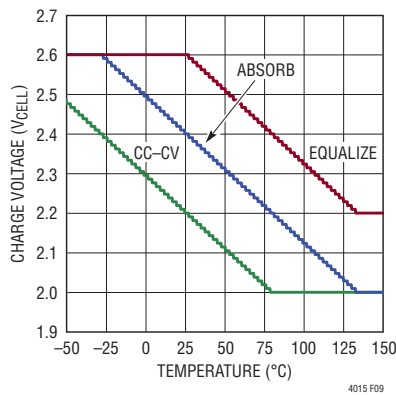

Figure 9. Lead-Acid Temperature Profile

The LTC4015 limits lead-acid charge voltage to 2V to 2.6V/cell regardless of battery temperature in CC-CV, Absorb and equalize modes. VABSORB_DELTA is an adder to VCHARGE_SETTING in absorb mode. VEQUALIZE_DELTA is an adder to VCHARGE_SETTING in equalize mode.

At 25°C the default charge voltage is 2.2 V/cell. Using -3.65 mV/°C per cell, V_{CHARGE} will reach its minimum of 2.0V/cell at a temperature of 80°C. Similarly, V_{CHARGE} reaches its maximum of 2.6V/cell at a temperature of -85°C .

The default VABSORB_DELTA value is 0x15 (21 decimal). This translates to an absorb voltage of 2.4V/cell at 25°C.

The default VEQUALIZE_DELTA value is 0x2A (42 decimal). This translates to an equalize voltage of 2.6V/cell at 25°C.

Temperature compensation is active over a NTC_RATIO range of 21437 to 912, which corresponds to an approximate temperature range of -55°C to 135°C using a thermistor with a β value of 3490K such as the Vishay NTCS0402E3103FLT or NTHS0402N02N1002JE. See Figure 9.

Table Default Lead-Acid Temperature Compensation

PARAMETER:	REGISTERS THAT DETERMINE 25°C VALUE:	DEFAULT VALUE AT 25°C (VOLTS/CELL)
$V_{EQUALIZE}$	VCHARGE_SETTING+VEQUALIZE_DELTA	2.6
V_{ABSORB}	VCHARGE_SETTING+VABSORB_DELTA	2.4
V_{CHARGE}	VCHARGE_SETTING	2.2

Coulomb Counter

The LTC4015 features an integrated Coulomb counter for battery state of charge monitoring. Charge is the time integral of current. The Coulomb counter is disabled by default, and can be enabled only via the I²C port (en_qcount).

There are several I²C accessible registers associated with the Coulomb counter. The LO and HI alerts listed below can be disabled. See register map and detailed register descriptions for details.

en_qcount	1-Bit	Enable Coulomb Counter (0x14, Bit 2)
en_qcount_lo_alert	1-Bit	Enable Coulomb Counter Low Alert. (0x0D Bit 13)
en_qcount_hi_alert	1-Bit	Enable Coulomb Counter High Alert. (0x0D Bit 12)
QCOUNT	16-Bits	Coulomb Counter Accumulator Value (0x13)
QCOUNT_LO_ALERT_LIMIT	16-Bits	Coulomb Counter Accumulator Low Alert Limit. (0x10)
QCOUNT_HI_ALERT_LIMIT	16-Bits	Coulomb Counter Accumulator High Alert Limit. (0x11)
QCOUNT_PRESCALE_FACTOR	16-Bits	Coulomb Counter Prescale Factor. (0x12)

The LTC4015 does not directly sense battery current, but instead senses $V_{CSP-CSN}$ developed across R_{SNSB} . This voltage is divided by the value of R_{SNSB} to calculate current. The Coulomb counter integrates $V_{CSP-CSN}$ to infer charge. The differential voltage across R_{SNSB} is applied to a voltage to the frequency converter (V-to-F). When the integrator portion of the V-to-F output ramps to the CCREFP or CCREFM level, switches S1, S2, S3 and S4 toggle to reverse the ramp direction. By observing the state of the switches and the ramp direction, polarity is determined. The frequency of this ticking is directly proportional to $V_{CSP-CSN}$. The coulomb counter V-to-F transfer function is:

$$f_{TICK} = K_{QC} \cdot V_{CSP-CSN}$$

OPERATION

Where $K_{QC} = 8333.33\text{Hz/V}$

f_{TICK} is then divided by a prescaler (QCOUNT_PRESCALE_FACTOR) that is programmable from 1 to 65535 (default of 512). The prescaler effectively increases integration time by a factor equal to QCOUNT_PRESCALE_FACTOR. At each under or overflow of the prescaler, the accumulated voltage register (QCOUNT) is incremented or decremented one count. The value of accumulated voltage is read via the I²C interface.

To achieve the specified precision of the Coulomb counter the differential voltage $V_{\text{CSP-CSN}}$ must stay within $\pm 50\text{mV}$. For differential input signals up to $\pm 300\text{mV}$ the Coulomb counter will remain functional but the precision of the Coulomb counter is not guaranteed.

The value of external sense resistor, R_{SNSB} , influences the gain of the Coulomb counter. A larger sense resistor gives a larger differential voltage for the same current which results in more precise Coulomb counting. Thus the amount of charge represented by the least significant bit (q_{LSB}) of the accumulated charge is given by:

$$q_{\text{LSB}} = \frac{\text{QCOUNT_PRESCALE_FACTOR}}{K_{\text{QC}} \cdot R_{\text{SNSB}}}$$

q_{LSB} units are in coulombs (Amp-seconds)

where:

$$K_{\text{QC}} = 8333.33\text{Hz/V}$$

QCOUNT_PRESCALE_FACTOR = value of the prescaler

R_{SNSB} is in Ω

If the value of QCOUNT reaches 0 or 65535, the value saturates. QCOUNT does not wrap.

As long as input power is applied and the battery charger is enabled, the LTC4015 will allow lead-acid batteries to remain in a CV state indefinitely. As the battery slowly discharges itself internally, the LTC4015 replenishes the lost charge, and this charge is accumulated by the Coulomb counter. After a long period of time, the Coulomb counter accumulated charge due to battery self discharge current while the charger is in CV mode could cause significant errors relative to the actual SOC of the battery.

Coulomb Counter Applications

The following examples demonstrate simple applications of the LTC4015 Coulomb counter function. For more advanced applications, including calibration of state-of-charge based on temperature, please contact Linear Technology Applications Engineering for more information.

EXAMPLE: Setting QCOUNT_PRESCALE_FACTOR and initializing and calibrating QCOUNT: Charging two Li-Ion 3.5Ah batteries in parallel at 6.4A total

$$\text{Total capacity} = 7.0 \text{ Ah} = 7.0\text{A} \cdot 3600\text{sec} = 25200\text{C}$$

$$\text{Constant-current charging at } 6.4\text{A} \text{ requires } R_{\text{SNSB}} = \frac{32\text{mV}}{6.4\text{A}} = 5\text{m}\Omega$$

The maximum value of the QCOUNT register is 65535. To prevent over ranging QCOUNT, the highest allowed value of q_{LSB} is $25200\text{C}/65535 = 0.385\text{C}$

Using:

$$q_{\text{LSB}} = \frac{\text{QCOUNT_PRESCALE_FACTOR}}{K_{\text{QC}} \cdot R_{\text{SNSB}}}$$

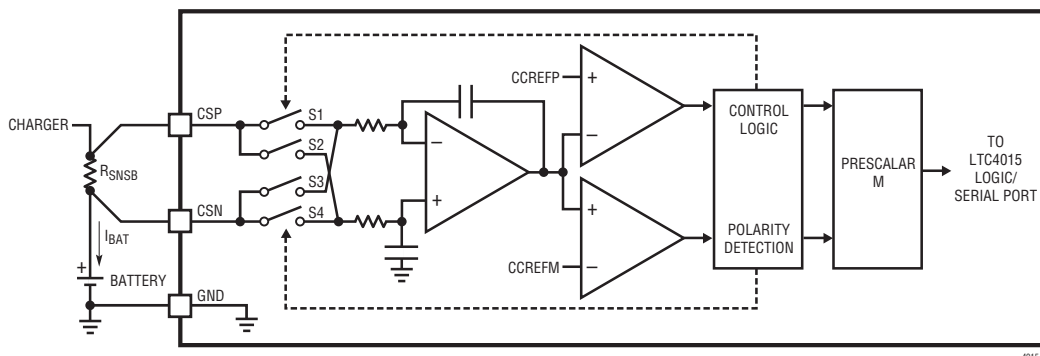

Figure 10. Coulomb Counter Section of the LTC4015

OPERATION

In order to achieve a q_{LSB} of at least $0.385C$, $QCOUNT_PRESCALE_FACTOR$ must be at least $q_{LSB} \cdot (K_{QC} \cdot R_{SNSB}) = 0.385 \cdot (8333.33 \cdot 0.005)$. Doubling (to allow for margin) and rounding to the nearest integer gives $QCOUNT_PRESCALE_FACTOR = 32$.

The initial state of charge (SOC) of the battery is known to be approximately 25%. Given that the $QCOUNT_PRESCALE_FACTOR = 32$ has now been set for approximately twice the capacity of the battery, the desired valid range of $QCOUNT$ is from 16384 (to represent 0% SOC) to 49152 (to represent 100% SOC). The value of $QCOUNT$ is thus initialized to $(32768 \cdot 0.25) + 16384 = 24576$ to represent the approximate 25% initial SOC. In this case, the SOC of the battery at any time can be calculated as $100\% \cdot (QCOUNT - 16384) / 32768$.

Upon the first termination ($c_over_x_term=1$ or $timer_term=1$), the battery is known to be very near 100% SOC, so the value of $QCOUNT$ can be calibrated accordingly. For example, if the initial state of charge was actually 23% instead of the expected 25%, termination will occur when $QCOUNT$ is approximately 49806. Upon the first termination, the value of $QCOUNT$ is overwritten to 49152 to calibrate $QCOUNT$ to the true SOC of the battery.

EXAMPLE: Coulomb Counter Charge Termination

The Coulomb counter alert limits can be used to implement a maximum state of charge termination algorithm. The following example demonstrates such a procedure:

- 1) Set the Coulomb counter register ($QCOUNT$) to the battery's initial state of charge, and set $QCOUNT_PRESCALE_FACTOR$ based on the battery capacity, as indicated in the example above.
- 2) Set $QCOUNT_HI_ALERT_LIMIT$ to the desired maximum state of charge of the battery (e.g. $QCOUNT_HI_ALERT_LIMIT = 49152$)
- 3) Set $en_qcount_hi_alert=1$
- 4) If the battery charges enough that $QCOUNT$ exceeds $QCOUNT_HI_ALERT_LIMIT$, the LTC4015 will issue an SMBALERT and set $qcount_hi_alert=1$. After completing the alert response algorithm and verifying that the LTC4015 is issuing $qcount_hi_alert=1$, set

$suspend_charger=1$ to stop the battery from charging. At this time, write $QCOUNT_LO_ALERT_LIMIT$ to a lower level corresponding to a recharge threshold (e.g. $QCOUNT_LO_ALERT_LIMIT = 0.95 \cdot QCOUNT_HI_ALERT_LIMIT$) and set $en_qcount_lo_alert=1$ and $en_qcount_hi_alert=0$.

- 5) When the battery discharges enough that $QCOUNT$ falls below $QCOUNT_LO_ALERT_LIMIT$, the LTC4015 will issue an SMBALERT and set $qcount_lo_alert=1$. After completing the alert response algorithm and verifying that the LTC4015 is issuing $qcount_lo_alert=1$, set $en_qcount_lo_alert=0$, $en_qcount_hi_alert=1$, and $suspend_charger=0$ to allow the battery to charge again.

Step Down Switching Charger Controller

The LTC4015's primary power path is a fully synchronous step down switching charger controller. Due to its all NMOS design, a diode and capacitor are required to provide high side boosted drive. Taking error signals from four control loops simultaneously, the feedback paths are externally compensated with a RC network connected to the V_C pin.

The switching controller is designed to charge single or multiple batteries. Normal charging proceeds at a constant-current until the batteries reach their target voltage. The maximum charge current is determined by the value of the sense resistor, R_{SNSB} , used in series with the inductor. The charge current loop servos the voltage across R_{SNSB} to the value determined by $ICHARGE_DAC$.

When charging is enabled an internal soft-start will ramp up the charge current from zero to $ICHARGE_TARGET$. Both the battery voltage and charge current can be read back over I^2C . The LTC4015 provides constant power charging by limiting input current drawn by the switching controller. The input current limit will reduce charge current to limit the voltage across the input sense resistor, R_{SNSI} , to $IIN_LIMIT_SETTING$. If the combined system load plus battery charge current is large enough to cause the switching controller to reach the programmed input current limit, the input current limit loop will reduce the charge current. Even if the charge current is programmed to exceed the allowable input current, the input current will not be violated; the charger will reduce its current as needed. The input current can be read back over I^2C .

OPERATION

DRV_{CC}

The bottom gate driver is powered from the DRV_{CC} pin. DRV_{CC} is normally connected to the INTV_{CC} pin. An external LDO or DC/DC converter can also be used to power the top and bottom gate driver to minimize power dissipation inside the IC. The use of a DC/DC for DRV_{CC} can also minimize power dissipation in general.

INTV_{CC}/DRV_{CC} and IC Power Dissipation

The LTC4015 features an internal PMOS low dropout linear regulator (LDO) that supplies power to INTV_{CC} from V_{SYS}. INTV_{CC} powers the gate drivers (when DRV_{CC} is connected to INTV_{CC}) and much of the LTC4015's internal circuitry. The INTV_{CC} LDO regulates the voltage at the INTV_{CC} pin to 5V. The LDO can supply a maximum current of 50mA and must be bypassed to ground with a ceramic capacitor with a minimum value of 4.7μF. If DRV_{CC} is not connected to INTV_{CC}, it should have at least a 2.2μF ceramic or low ESR electrolytic capacitor. No matter what type of bulk capacitor is used on DRV_{CC}, an additional 0.1μF ceramic capacitor placed directly adjacent to the DRV_{CC} pin and GND is highly recommended. Good bypassing is needed to supply the high transient currents required by the MOSFET gate drivers. High input voltage applications in which large MOSFETs are being driven at high frequencies may cause the maximum junction temperature rating for the LTC4015 to be exceeded. The DRV_{CC} current, which is dominated by the gate charge current, is supplied by the INTV_{CC} LDO. Power dissipation for the IC in this case is highest and is approximately equal to (V_{SYS}) • (I_Q + I_G), where I_Q is the non-switching quiescent current of ~4mA and I_G is gate charge current. The junction temperature can be estimated by using the equations given in Note 2 of the Electrical Characteristics. For example, the I_G supplied by the INTV_{CC} LDO is limited to less than 42mA from a 35V supply in the QFN package at a 70°C ambient temperature:

$$T_J = 70^\circ\text{C} + (35\text{V})(4\text{mA} + 42\text{mA})(34^\circ\text{C}/\text{W}) = 125^\circ\text{C}$$

To prevent the maximum junction temperature from being exceeded, the DRV_{CC} current must be checked while operating in continuous conduction mode at maximum V_{SYS}.

The power dissipation in the IC is significantly reduced if DRV_{CC} is powered from an external LDO. In this case the power dissipation in the IC is equal to power dissipation due to I_Q and the power dissipated in the gate drivers, (VDRV_{CC}) • (I_G). Assuming the external DRV_{CC} LDO output is 5V and is supplying 42mA to the gate drivers, the junction temperature rises to only 82°C:

$$T_J = 70^\circ\text{C} + [(35\text{V})(4\text{mA}) + (5\text{V})(42\text{mA})](34^\circ\text{C}/\text{W}) = 82^\circ\text{C}$$

If DRV_{CC} is powered from an external LDO, the LDO should be powered from V_{SYS} and its output must be less than 5.5V. In this case, DRV_{CC} should not be tied to INTV_{CC}. Sequencing is also important, if DRV_{CC} is not tied to INTV_{CC}, DRV_{CC} should not be applied until INTV_{CC} has reached 3V to ensure the gate drivers are held off.

Die Temperature Sensor

The LTC4015 has an integrated die temperature sensor. It is monitored by the ADC and is digitized to the DIE_TEMP register. An alarm may be set on die temperature by setting the DIE_TEMP_LO_ALERT_LIMIT and/or DIE_TEMP_HI_ALERT_LIMIT registers and enabling the alarms in the EN_LIMIT_ALERTS register.

INTV_{CC} and DRV_{CC} UVLO

Internal undervoltage lockout circuits monitor both the INTV_{CC} and DRV_{CC} pins. The switching controller is kept off until INTV_{CC} rises above 4.3V and DRV_{CC} is above 4.2V. Hysteresis on the UVLOs turn off the controller if either INTV_{CC} falls below 4V or DRV_{CC} falls below 3.9V. Charging is not enabled until V_{IN} is 200mV above the battery voltage. Charging is disabled when V_{IN} falls to within 100mV of the battery voltage.

Input Overvoltage Protection

The LTC4015 has overvoltage detection on its input. If V_{IN} exceeds 38.6V, the switching controller will hold both switches off. The controller will resume switching if V_{IN} falls below 37.2V.

APPLICATIONS INFORMATION

NTC Resistor Selection

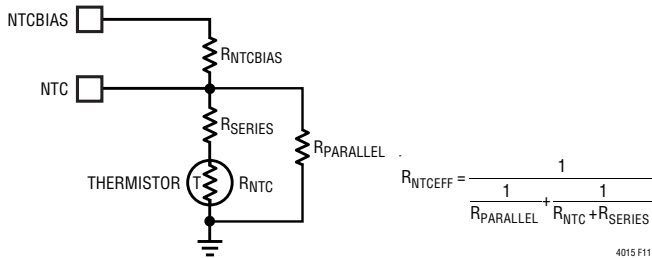

Figure 11

With minor modifications to the thermistor bias network, it is possible to adjust the effective temperature profile of the thermistor. Note that this technique can generally only reduce the slope of the temperature profile—it is not possible to increase the sensitivity of the thermistor.

The temperature based charging characteristics of the LTC4015 are based on the ADC reading NTC_RATIO. For the alternate thermistor bias network shown in Figure 11, the value of NTC_RATIO is determined by:

$$\text{NTC_RATIO} = 21845 \cdot \frac{R_{\text{NTCEFF}}}{R_{\text{NTCTBIAS}} + R_{\text{NTCEFF}}}$$

The values of R_{NTCTBIAS} , R_{PARALLEL} , and R_{SERIES} can be selected in order to achieve a desired temperature profile for NTC_RATIO. Note that thermistor temperature profiles are highly nonlinear; consult manufacturers' documentation for data on a specific thermistor. Two examples are included here as a demonstration

Example 1: For a lithium chemistry battery with a 100k Ω Vishay NTHS0402N01N1003J NTC thermistor, using $R_{\text{NTCTBIAS}} = 100\text{k}\Omega$, $R_{\text{PARALLEL}} = 2\text{M}\Omega$, and $R_{\text{SERIES}} = 5\text{k}\Omega$ will approximately mimic the profile of a thermistor β value of 3490k over the range 0°C to 60°C, resulting in less than 1°C of error (typical) for the default JEITA temperature thresholds (defined by JEITA_Tn, see JEITA Temperature Controlled Charging). This error is significantly less than the error tolerance of most thermistors.

Example 2: For a lead-acid battery with a 100k Ω Vishay NTHS0402N01N1003J NTC thermistor, using $R_{\text{NTCTBIAS}} = 95\text{k}\Omega$, $R_{\text{PARALLEL}} = 5\text{M}\Omega$, and $R_{\text{SERIES}} = 2\text{k}\Omega$ will approxi-

mately mimic the profile of a thermistor β value of 3490k over the range –40 to 125°C, resulting in less than 5°C of error (typical) for the lead-acid temperature charging profile (see Lead-Acid Temperature Compensated Charging), which in turn results in a battery voltage error of less than 20mV/cell over temperature.

Setting the R_T Resistor

A resistor on the RT pin sets the LTC4015's step down regulator switching frequency. To keep the inductor size down and ensure optimum efficiency and stability the LTC4015 switching frequency can be optimized (see Inductor Selection section). An R_T value of 95.3k resistor sets the frequency to 500kHz:

$$f_{\text{OSC(MHz)}} = \frac{47.65}{R_T(\text{k}\Omega)}$$

Setting Input and Charge Currents

As mentioned previously, maximum average charge current is determined by the value of the sense resistor R_{SNSB} , connected between CSP and CSN, which is in series with the inductor. The maximum average input current is determined by the resistance R_{SNSI} , connected between the CLP and CLN pins. The input and charge current loops servo the voltages across their respective sense resistors to a maximum of 32mV. Therefore the maximum input and charge average currents are:

$$I_{\text{IN(MAX)}} = \frac{32\text{mV}}{R_{\text{SNSI}}} \quad I_{\text{CHG(MAX)}} = \frac{32\text{mV}}{R_{\text{SNSB}}}$$

Compensation

The input current, charge current, V_{BAT} voltage and UVCL voltage loops all require a 6.8nF to 14.7nF capacitor from the V_C node to ground.

When using the MPPT feature with resistive sources in excess of 0.5 Ω , the required V_C capacitor (C_{V_C}) may be in the 100's of nF, with an additional series resistor in the 100 Ω to 1000 Ω range. If a series R is used, a smaller cap, $C_{V_C}/10$, should be placed directly from V_C to ground.

APPLICATIONS INFORMATION

If testing is to be done with a electronic load in constant-current mode, care must be taken if using CC mode that instability may occur. A few milli Farads on V_{BAT} , with enough series R (e.g. ESR) to give a zero around 1kHz range can help in this situation.

Inductor Selection

The operating frequency and inductor selection are interrelated. Higher operating frequencies allow the use of smaller inductor and capacitor values but generally also results in lower efficiency because of MOSFET switching and gate charge losses. In addition, the effect of inductor value on ripple current must also be considered. The inductor ripple current decreases with higher inductance or higher frequency and increases with higher V_{IN} . Accepting larger values of ripple current allows the use of low inductances, but results in higher output voltage ripple and greater core losses. For the LTC4015, the best overall performance will be attained if the inductor is chosen to be:

$$L = \frac{V_{BAT} \cdot (1 - V_{BAT}/V_{IN(MAX)})}{0.25 \cdot f \cdot I_{CHG(MAX)}}$$

Where V_{BAT} is the highest BATSENS voltage, $V_{IN(MAX)}$ is the maximum input voltage, $I_{CHG(MAX)}$ is the maximum regulated charge current and f_{SW} is the switching frequency. Using these equations, the inductor ripple will be at most 25% of $I_{CHG(MAX)}$. Once the value for L is known, the type of inductor core must be selected. Ferrite cores are recommended for their very low core loss. Selection criteria should concentrate on minimizing copper loss and preventing saturation. Ferrite core material saturates hard, which means that inductance collapses abruptly when the peak design current is exceeded. This causes an abrupt increase in inductor ripple current and consequent output voltage ripple. Do not allow the core to saturate! The saturation current for the inductor should be at least 60% higher than the maximum regulated current, $I_{CHG(MAX)}$.

C_{SYS} and C_{BAT} Capacitance

The specification for C_{SYS} will be determined by the desired ripple voltage:

$$\Delta V_{SYS} = \frac{V_{BAT}}{V_{SYS}} \left(1 - \frac{V_{BAT}}{V_{SYS}} \right) \frac{I_{CHG(MAX)}}{C_{SYS} \cdot f_{SW}} + I_{CHG(MAX)} \cdot ESR_{CSYS}$$

In continuous mode, the source current of the top MOSFET is a square wave of duty cycle (V_{BAT}/V_{SYS}). To prevent large voltage transients, a low ESR capacitor sized for the maximum RMS current must be used. The maximum RMS capacitor current is given by:

$$I_{RMS} = I_{CHG(MAX)} \frac{V_{BAT}}{V_{SYS}} \sqrt{\frac{V_{SYS}}{V_{BAT}} - 1}$$

This formula has a maximum at $V_{SYS} = 2 V_{BAT}$, where $I_{RMS} = I_{CHG(MAX)}/2$. This simple worst-case condition is commonly used for design because even significant deviations do not offer much relief. Medium voltage (20V to 35V) ceramic, tantalum, OS-CON and switcher rated electrolytic capacitors can be used as input capacitors. Sanyo OS-CON SVP, SVPD series; Sanyo POSCAP TQC series or aluminum electrolytic capacitors from Panasonic WA series or Cornell Dubilier SPV series, in parallel with a couple of high performance ceramic capacitors, can be used as an effective means of achieving low ESR and high bulk capacitance.

The purpose of the V_{BAT} capacitor is to filter the inductor current ripple as well as to stabilize the charger if the battery is not present or has high BSR. The V_{BAT} ripple (ΔV_{BAT}) is approximated by:

$$\Delta V_{BAT} = \Delta I_{P-P} \left(\frac{1}{8 \cdot C_{BAT} \cdot f_{SW}} + ESR_{CBAT} \right)$$

Where f_{SW} is the operating frequency, C_{BAT} is the capacitance on V_{BAT} and ΔI_{P-P} is the ripple current in the inductor. The output ripple is highest at maximum input voltage since ΔI_{P-P} increases with input voltage.

Power MOSFET Selection

Two external power MOSFETs must be selected for the LTC4015's synchronous controller: one N-channel MOSFET for the top switch and one N-channel MOSFET for the bottom switch. The selection criteria of the external N-channel power MOSFETs include maximum drain-source voltage (V_{DSS}), threshold voltage, on-resistance ($R_{DS(ON)}$), reverse transfer capacitance (C_{RSS}), total gate charge (Q_G) and maximum continuous drain current. V_{DSS} should be selected to be higher than the maxi-

APPLICATIONS INFORMATION

imum input supply voltage (including transient) for both MOSFETs. The peak-to-peak drive levels are set by the DRV_{CC} voltage. Logic-level threshold MOSFETs must be used because DRV_{CC} is powered from either $INTV_{CC}$ (5V) or an external LDO whose output voltage must be less than 5.5V. MOSFET power losses are determined by $R_{DS(ON)}$ and C_{RSS} and Q_G .

The conduction loss at maximum charge current for the top MOSFET switches are:

$$P_{COND(TOP)} = \left(\frac{V_{BAT}}{V_{SYS}} \cdot I_{CHG(MAX)}^2 \cdot R_{DS(ON)} \right) (1 + \delta\Delta T)$$

$$P_{COND(BOT)} = \left(\left(1 - \frac{V_{BAT}}{V_{SYS}} \right) I_{CHG(MAX)}^2 \cdot R_{DS(ON)} \right) (1 + \delta\Delta T)$$

The term $(1 + \delta\Delta T)$ is generally given for a MOSFET in the form of a normalized $R_{DS(ON)}$ vs Temperature curve, but $\delta = 0.005/^\circ C$ can be used as an approximation for low voltage MOSFETs. Both MOSFET switches have conduction loss. However, transition loss occurs only in the top MOSFET in step-down converter. This loss is proportional to V_{SYS}^2 and can be considerably larger in high voltage applications ($V_{SYS} > 20V$). The maximum transition loss is:

$$P_{TRAN} = k/2 \cdot (V_{SYS})^2 \cdot I_{CHG(MAX)} \cdot C_{RSS} \cdot f_{SW}$$

where k is related to the drive current during the Miller plateau and is approximately equal to one.

Choosing a high side MOSFET that has a higher $R_{DS(ON)}$ and lower C_{RSS} can minimize overall losses; by reducing transition losses more than the corresponding conduction loss increase.

Another power loss related to switching MOSFET selection is the power lost to driving the gates. The total gate charge, Q_G , must be charged and discharged each switching cycle. The power is lost to the internal LDO and gate drivers within the LTC4015. The power lost due to charging the gates is:

$$P_G = (Q_{G(TOP)} + Q_{G(BOT)}) \cdot f_{SW} \cdot V_{SYS}$$

Schottky Diode Selection

Optional Schottky diodes can be placed in parallel with the top and bottom MOSFET switches. These diodes clamp

SW during the non-overlap times between conduction of the top and bottom MOSFET switches. This prevents the body diodes of the MOSFET switches from turning on, storing charge during the non-overlap time and requiring a reverse recovery period that could cost as much as 3% in efficiency at high V_{IN} . One or both diodes can be omitted if the efficiency loss can be tolerated. The diode can be rated for about one-half to one-fifth of the full load current since it is on for only a fraction of the duty cycle. Larger diodes result in additional switching losses due to their larger junction capacitance. In order for the diodes to be effective, the inductance between them and the top and bottom MOSFETs must be as small as possible. This mandates that these components be placed next to each other on the same layer of the PC board.

Top MOSFET Driver Supply (C_B , D_B)

An external bootstrap capacitor, C_B , connected to the BOOST pin supplies the gate drive voltage for the top MOSFET. Capacitor C_B in Figure 12 is charged though external diode, D_B , from DRV_{CC} when the SW pin is low. The value of the bootstrap capacitor, C_B , needs to be 20 times that of the total input capacitance of the top MOSFET. The bypass capacitor on DRV_{CC} should be at least 10 times the value of C_B .

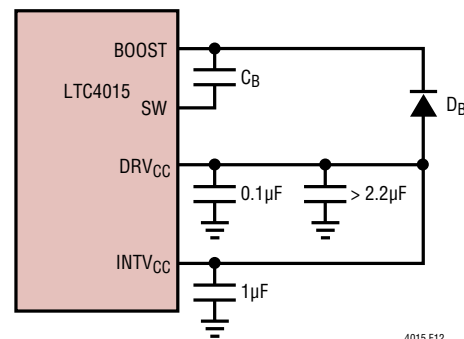

Figure 12. Bootstrap Capacitor/Diode and DRV_{CC} Connections

With the top MOSFET on, the boost voltage is above the system supply rail: $V_{BOOST} = V_{SYS} + V_{DRVCC}$.

The reverse break down of the external diode, D_B , must be greater than $V_{SYS(MAX)} + V_{DRVCC(MAX)}$.

D_B can be either a Schottky diode or a fast switching PN diode. Care must be taken to not exceed the maximum

APPLICATIONS INFORMATION

BOOST-SW voltage of 5.5V which may be possible with a Schottky under certain conditions, particularly if the step down charger is operating asynchronously. Fast switching PN diodes are recommended due to their low leakage and junction capacitance.

Minimum On-Time Considerations

Minimum on-time, $t_{ON(MIN)}$, is the smallest time duration that the LTC4015 is capable of turning on the top MOSFET. It is determined by internal timing delays and the gate charge required to turn on the top MOSFET. The minimum on-time for the LTC4015 is approximately 85ns. Low duty cycle applications may approach this minimum on-time limit. If the duty cycle falls below what can be accommodated by the minimum on-time, the controller will begin to skip cycles. The V_{BAT} voltage will continue to be regulated, but the ripple voltage and current will increase. If cycling skipping is undesirable care should be taken to ensure that:

$$\frac{V_{BAT}}{V_{SYS} \cdot f_{SW}} > t_{ON(MIN)} = 85ns$$

Ideal Diode MOSFET Selection

An external N-channel MOSFET is required for the input ideal diode and a P-channel MOSFET for output ideal diode. Important parameters for the selection of these MOSFETs are the maximum drain-source voltage, V_{DSS} , gate threshold voltage and on-resistance ($R_{DS(ON)}$). When the input is grounded the battery stack voltage is applied across the input ideal diode MOSFET. When V_{BAT} is at 0V, the input voltage is applied across the output ideal diode MOSFET. Therefore, the V_{DSS} of the input ideal diode MOSFET must withstand the maximum voltage on V_{BAT} while the V_{DSS} of output ideal diode MOSFET must withstand the highest voltage on V_{IN} . The gate drive for both ideal diodes is 5V. This requires the use of logic-level threshold P and N-channel MOSFETs. As a general rule, select MOSFETs with a low enough $R_{DS(ON)}$ to obtain the desired V_{DS} while operating at full load current. The LTC4015 will regulate the forward voltage drop across the input and output ideal diode MOSFETs at 15mV if $R_{DS(ON)}$ is low enough. The required $R_{DS(ON)}$ can be calculated by dividing 15mV by the load current in amps.

Achieving forward regulation will minimize power loss and heat dissipation, but it is not a necessity. If a forward voltage drop of more than 15mV is acceptable then a smaller MOSFET can be used, but must be sized compatible with the higher power dissipation. Care should be taken to ensure that the power dissipated is never allowed to rise above the manufacturer's recommended maximum level.

UVCLFB Resistor Divider Selection

The LTC4015 input undervoltage current limit (UVCL) function regulates voltage at the UVCLFB pin based on the value programmed in the `VIN_UVCL_SETTING` register. Do not write to the `VIN_UVCL_SETTING` register when MPPT is enabled.

If MPPT is enabled, the UVCLFB input voltage resistor divider must be set to 10k and 294k for the bottom and top resistors, respectively. Resistor tolerance should be $\pm 1\%$ or better.

These resistor values result in a gain of 30.4 from the UVCLB pin to V_{IN} . The 1.2V maximum servo level at UVCLFB would require the minimum V_{IN} at the maximum servo voltage to be greater than $1.2V \cdot 30.4 = 36.48V$, which is above the LTC4015's maximum V_{IN} . This is necessary to allow the MPPT algorithm to search across the entire V_{IN} range.

If maximum power point tracking (MPPT) is not enabled, the default undervoltage setting of `VIN_UVCL_SETTING = 0xFF` sets the UVCLFB undervoltage servo level to 1.2V. In this case, the input voltage resistor divider should be chosen such that $UVCLFB = 1.2V$ when V_{IN} is slightly above the higher of 4.3V or $V_{BAT(MAX)}$, to prevent undervoltage lockout (UVLO). For example, for a two cell Li-Ion application, the bottom and top resistors in the UVCLFB divider could be chosen as 75k and 470k, respectively, which sets the input undervoltage regulation limit at 8.72V. Note that when MPPT is disabled, and the MPPT UVCLFB 10k and 294k resistor divider values are used, the default `VIN_UVCL_SETTING` of 1.2V will result in the LTC4015 not charging the battery.

The undervoltage regulation feature can be disabled. The UVCLFB pin is clamped, the clamp begins to engage at 2V nominally. Care must be taken to keep switching noise from coupling on to the UVCLFB pin, a capacitor to signal GND may be required.

APPLICATIONS INFORMATION

1. Connect UVCLFB to $2P5V_{CC}$ through a 10k resistor. This method results in an additional $25\mu A$ to $50\mu A$ battery current drain when $V_{IN} < V_{BAT}$ as the $2P5V_{CC}$ LDO is powered by V_{BAT} in this condition.
2. Alternatively, the UVCLFB pin can be tied to V_{IN} through an appropriately sized resistor which keeps the pin current below $200\mu A$. This method results in zero battery current draw when $V_{IN} < V_{BAT}$. The 294k MPPT UVCLFB divider top resistor would meet this requirement.

When a UVCLFB input voltage resistor divider is present, if maximum power point tracking is disabled, input undervoltage regulation can be prevented by setting `VIN_UVCL_SETTING` to its lowest value (0x00).

UVCL and MPPT When Available Input Power is Low

The LTC4015 battery charger function requires a minimum amount of current to operate, which varies depending on the application (switching MOSFET selection, compensation, etc). If the maximum input current available from the V_{IN} supply is above 2mA to 3mA but below the minimum level required to operate the charger (generally approximately in the range 5mA to 20mA) then the battery may actually be discharged slightly by the charger. Under these conditions—for example, a very dimly lit (but not completely dark) solar panel—the worst-case battery drain current is generally less than 10mA, and persists only as long as the available input current from the V_{IN} source remains in this range. If the available input current falls to below 2mA to 3mA, then the battery discharge returns to near normal battery only mode levels. As such, if the input source is a solar panel, this battery drain will generally be short-lived and infrequent enough (for example, for a brief period shortly before sunrise and after sunset) as to be insignificant. However, if this drain is a concern, it can be mitigated by disabling the charger (setting `suspend_charger=1`) whenever I_{CHG} falls below 1% of full-scale ($I_{BAT} \leq 218$), and retrying (writing `suspend_charger=0`) periodically (e.g. every 60 seconds). Optionally, this retry can be limited to only occur when V_{IN} is above a known good threshold.

PCB Layout Considerations

When laying out the printed circuit board, the following guidelines should be used to ensure proper operation of the IC. Check the following in your layout:

1. Keep M1, M2, D1, D2 and C_{SYS} close together. The high dI/dt loop formed by the MOSFETs, Schottky diodes and C_{SYS} shown in Figure 13 should have short wide traces to minimize high frequency noise and voltage stress from inductive ringing. Surface mount components are preferred to reduce parasitic inductances from component leads. Connect the drain of the top MOSFET and cathode of the top diode directly to the positive terminal of C_{SYS} . Connect the source of the bottom MOSFET and anode of the bottom diode directly to the negative terminal of C_{SYS} . This capacitor provides the AC current to the MOSFETs.
2. GND is referenced to the negative terminal of the V_{BAT} decoupling capacitor. The negative terminal of C_{SYS} should be as close as possible to negative terminal of C_{BAT} by placing the capacitors next to each other and away from the switching loop described above. The combined IC ground pin/paddle and the ground return of C_{INTVCC} and C_{DRVCC} must return to the combined negative terminals of C_{SYS} and C_{BAT} .
3. Effective grounding techniques are critical for successful DC/DC converter layouts. Orient power components such that switching current paths in the ground plane do not cross through the GND pin and exposed pad on the backside of the LTC4015. Switch path currents can be controlled by orienting the MOSFET switches, Schottky diodes, the inductor, and V_{SYS} and V_{BAT} decoupling capacitors in close proximity to each other.
4. Route CSP and CSN sense lines together, keep them short. Place a 1nF ceramic capacitor across CSP-CSN as close as possible to the LTC4015. Filter components should be placed near the part and not near sense resistor. Ensure accurate current sensing with Kelvin connections at the sense resistors. See Figure 14.
5. Route CLP and CLN sense lines together, keep them short. Filter components should be placed near the part and not near sense resistor. Ensure accurate current sensing with Kelvin connections at the sense resistors. See Figure 15.

APPLICATIONS INFORMATION

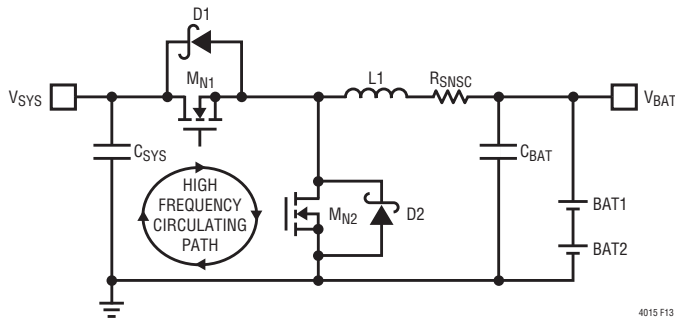

Figure 13. High Speed Switching Path

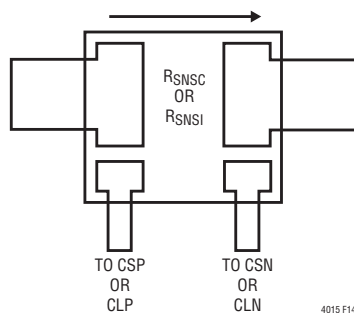

Figure 14. Kelvin Current Sensing

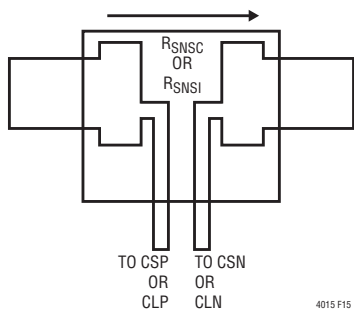

Figure 15. Kelvin Current Sensing

6. Locate the DRV_{CC} and BOOST decoupling capacitors in close proximity to the IC. These capacitors carry the MOSFET drivers' high peak currents. An additional $0.1\mu F$ ceramic capacitor placed immediately next to the DRV_{CC} pin can help improve noise performance substantially.
7. Locate the small signal components away from high frequency switching nodes (BOOST, SW, TG, and BG). All of these nodes have very large and fast moving signals and therefore should be kept on the output side of the LTC4015.

8. The input ideal diode senses the voltage between V_{IN} and V_{CLP} . V_{IN} should be connected near the source of the input ideal diode MOSFET. V_{CLP} is used for Kelvin sensing the input current. Place the input current sense resistor, R_{SNSI} , near the input ideal diode MOSFET with a short, wide trace to minimize resistance between the drain of the ideal diode MOSFET and R_{SNSI} .
9. The output ideal diode senses the voltage between V_{SYS} and V_{CSP} . V_{SYS} should be connected near the source of the output ideal diode MOSFET. V_{CSP} is used for Kelvin sensing the charge current. Place the output ideal diode near the charge current sense resistor, R_{SNSB} , with a short, wide trace to minimize resistance between the drain of the ideal diode MOSFET and R_{SNSB} .

LTC4015 Digital System

This section provides a detailed explanation of the functions of the LTC4015 digital system available via the serial port registers.

LTC4015 Digital System Usage Examples 1, 2

The following usage examples describe applications which demonstrate a range of functionality available with the LTC4015 system. Note that these examples represent only a small fraction of the LTC4015's full digital functionality.

LTC4015 Digital System Usage Example 1: Coulomb counter and Low Limit Alert Only

Upon initial power up with an embedded battery in a known state of charge, the serial port master writes the LTC4015 bit $en_qcount=1$, enabling the Coulomb counter. Register $QCOUNT$ is initialized to reflect the known state of charge, $QCOUNT_PRESCALE_FACTOR$ is written for optimum range and resolution, $QCOUNT_LO_ALERT_LIMIT$ is written to a value known to correspond to a critical low state of charge, and $en_qcount_lo_alert$ is written to 1.

If the state of charge falls below the level defined by $QCOUNT_LO_ALERT_LIMIT$, the LTC4015 pulls down the $SMBALERT$ pin. The serial port master performs an alert response algorithm (ARA) which confirms that the LTC4015 is the source of the alert and causes the LTC4015 to release the $SMBALERT$ pin. The master then reads the

APPLICATIONS INFORMATION

LIMIT_ALERTS register to confirm that `qcount_lo_alert` is true. The master then initiates appropriate system action (e.g. emergency power down, user warning, etc).

See the sections Coulomb Counter, Programmable Interrupt Controller, and Detailed Register Descriptions for more details.

LTC4015 Digital System Usage Example 2: Custom Battery Charger Settings for a Lead-Acid Battery Pack with Battery Overtemperature Alert.

The LTC4015 CHEM1 and CHEM0 pins are strapped to select the chemistry algorithm. Upon initial power-up, the serial port master writes `suspend_charger=1`, then writes `VCHARGE_SETTING`, `VABSORB_DELTA`, `MAX_ABSORB_TIME`, `VEQUALIZE_DELTA`, and `EQUALIZE_TIME` based on the battery manufacturer's recommendation for charge voltage and time. The master writes `NTC_RATIO_LO_ALERT_LIMIT` to the value of `NTC_RATIO` which corresponds to the maximum safe charging temperature for the battery pack and NTC thermistor, and writes `en_ntc_ratio_lo_alert = 1`. The master then re-enables the battery charger by writing `suspend_charger=0`. At regular long intervals (for example, every 30 days) the master optionally initiates an equalization charge by asserting the EQ pin.

If the thermistor temperature ever exceeds the level corresponding to `NTC_RATIO_LO_ALERT_LIMIT`, the LTC4015 pulls down the SMBALERT pin. The serial port master then performs an ARA which confirms that the LTC4015 is the source of the alert and causes the LTC4015

to release the SMBALERT pin. The master reads the LIMIT_ALERTS register to confirm that `ntc_ratio_lo_alert` is true. The master then writes `suspend_charger=1` to disable the battery charger.

Optionally, in order to detect when the battery temperature has returned to a safe level for charging, the master writes `NTC_RATIO_HI_ALERT_LIMIT` to a value corresponding to 5°C below the maximum safe charging temperature of the battery, and writes `en_ntc_ratio_hi_alert=1`. When the thermistor temperature falls below this level, the LTC4015 generates a new $\overline{\text{SMBALERT}}$ for `ntc_ratio_hi_alert=1`, which is again confirmed by the master. The master then disables the alert by writing `en_ntc_ratio_hi_alert=0`, clears `ntc_ratio_lo_alert` (by writing a 0 to that bit), then re-enables the charger by writing `suspend_charger=0`.

See the sections Lead-Acid Battery Charge Algorithm, Programmable Interrupt Controller, and Detailed Register Descriptions for more details.

LTC4015 Digital System Usage Example 3: Battery Charger State Monitoring

The serial port master writes `en_charger_suspended_alert=1` to generate an alert if the battery charger is ever disabled (e.g. due to the removal of V_{IN} input power). If V_{IN} input power is removed, the LTC4015 pulls down the SMBALERT pin and sets the `charger_suspended` bit to 1. After performing an ARA, the serial port master directs the system to minimize battery drain (e.g. dimming displays, powering down unnecessary functions, etc).

REGISTER DESCRIPTION

Serial Port Register Map. All bits are active high. Registers are unsigned except where noted. All registers contain 16 bits. Unused register bits as well as registers 0x17, 0x18, 0x49 are reserved and should not be written.

SYMBOL	SUB ADDR	R/W	ACTIVE BITS	DESCRIPTION	DEFAULT	PAGE
VBAT_LO_ALERT_LIMIT	0x01	R/W	15:0	Battery voltage low alert limit, signed, same format as VBAT (0x3A)	0x0000	55
VBAT_HI_ALERT_LIMIT	0x02	R/W	15:0	Battery voltage high alert limit, signed, same format as VBAT (0x3A)	0x0000	55
VIN_LO_ALERT_LIMIT	0x03	R/W	15:0	Input voltage low alert limit, signed, same format as VIN (0x3B)	0x0000	55
VIN_HI_ALERT_LIMIT	0x04	R/W	15:0	Input voltage high alert limit, signed, same format as VIN (0x3B)	0x0000	55
VSYS_LO_ALERT_LIMIT	0x05	R/W	15:0	Output voltage low alert limit, signed, same format as VSYS (0x3C)	0x0000	55
VSYS_HI_ALERT_LIMIT	0x06	R/W	15:0	Output voltage high alert limit, signed, same format as VSYS (0x3C)	0x0000	55
IIN_HI_ALERT_LIMIT	0x07	R/W	15:0	Input current high alert limit, signed, same format as IIN (0x3D)	0x0000	55
IBAT_LO_ALERT_LIMIT	0x08	R/W	15:0	Charge current low alert limit, signed, same format as IBAT (0x3E)	0x0000	55
DIE_TEMP_HI_ALERT_LIMIT	0x09	R/W	15:0	Die temperature high alert limit, signed, same format as DIE_TEMP (0x3F)	0x0000	55
BSR_HI_ALERT_LIMIT	0x0A	R/W	15:0	Battery series resistance high alert limit, signed, same format as BSR (0x41)	0x0000	55
NTC_RATIO_HI_ALERT_LIMIT	0x0B	R/W	15:0	Thermistor ratio high (cold battery) alert limit, signed, same format as NTC_RATIO (0x40)	0x0000	55
NTC_RATIO_LO_ALERT_LIMIT	0x0C	R/W	15:0	Thermistor ratio low (hot battery) alert limit, signed, same format as NTC_RATIO (0x40)	0x0000	55
EN_LIMIT_ALERTS	0x0D	R/W	15:0	Enable limit monitoring and alert notification via SMBALERT	0x0000	56
en_meas_sys_valid_alert	0x0D	R/W	15	enable meas_sys_valid_alert (0x36)	0	56
	0x0D	R/W	14	RESERVED	0	
en_qcount_low_alert	0x0D	R/W	13	enable qcount_low_alert (0x36)	0	56
en_qcount_high_alert	0x0D	R/W	12	enable qcount_high_alert (0x36)	0	56
en_vbat_lo_alert	0x0D	R/W	11	enable vbat_lo_alert (0x36)	0	56
en_vbat_hi_alert	0x0D	R/W	10	enable vbat_hi_alert (0x36)	0	56
en_vin_lo_alert	0x0D	R/W	9	enable vin_lo_alert (0x36)	0	56
en_vin_hi_alert	0x0D	R/W	8	enable vin_hi_alert (0x36)	0	56
en_vsys_lo_alert	0x0D	R/W	7	enable vsys_lo_alert (0x36)	0	56
en_vsys_hi_alert	0x0D	R/W	6	enable vsys_hi_alert (0x36)	0	56
en_iin_hi_alert	0x0D	R/W	5	enable iin_hi_alert (0x36)	0	56
en_ibat_lo_alert	0x0D	R/W	4	enable ibat_lo_alert (0x36)	0	57
en_die_temp_hi_alert	0x0D	R/W	3	enable die_temp_hi_alert (0x36)	0	57
en_bsr_hi_alert	0x0D	R/W	2	enable bsr_hi_alert (0x36)	0	57
en_ntc_ratio_hi_alert	0x0D	R/W	1	enable ntc_ratio_hi alert (cold battery; 0x36)	0	57
en_ntc_ratio_lo_alert	0x0D	R/W	0	enable ntc_ratio_lo_alert (hot battery; 0x36)	0	57
EN_CHARGER_STATE_ALERTS	0x0E	R/W	15:0	Enable charger state alert notification via SMBALERT	0x0000	57
en_equalize_charge_alert	0x0E	R/W	10	enable lead-acid equalize_charge_alert (0x37)	0	57
en_absorb_charge_alert	0x0E	R/W	9	enable absorb_charge_alert (0x37)	0	57
en_charger_suspended_alert	0x0E	R/W	8	enable charger_suspended_alert (0x37)	0	57
en_precharge_alert	0x0E	R/W	7	enable precharge_alert (0x37)	0	57
en_cc_cv_charge_alert	0x0E	R/W	6	enable cc_cv_charge_alert (0x37)	0	57

REGISTER DESCRIPTION

SYMBOL	SUB ADDR	R/W	ACTIVE BITS	DESCRIPTION	DEFAULT	PAGE
en_ntc_pause_alert	0x0E	R/W	5	enable ntc_pause_alert (0x37)	0	58
en_timer_term_alert	0x0E	R/W	4	enable timer_term_alert (0x37)	0	58
en_c_over_x_term_alert	0x0E	R/W	3	enable c_over_x_term alert (0x37)	0	58
en_max_charge_time_fault_alert	0x0E	R/W	2	enable max_charge_time_fault alert (0x37)	0	58
en_bat_missing_fault_alert	0x0E	R/W	1	enable bat_missing_fault alert (0x37)	0	58
en_bat_short_fault_alert	0x0E	R/W	0	enable bat_short_fault alert (0x37)	0	58
EN_CHARGE_STATUS_ALERTS	0x0F	R/W	15:0	Enable charge status alert notification via SMBALERT	0x0000	58
en_vin_uvcl_active_alert	0x0F	R/W	3	enable vin_uvcl_active_alert (V_{IN} undervoltage current limit; 0x38)	0	58
en_iin_limit_active_alert	0x0F	R/W	2	enable iin_limit_active_alert (I_{IN} current limit; 0x38)	0	58
en_constant_current_alert	0x0F	R/W	1	enable constant_current_alert (0x38)	0	58
en_constant_voltage_alert	0x0F	R/W	0	enable constant_voltage_alert (0x38)	0	58
QCOUNT_LO_ALERT_LIMIT	0x10	R/W	15:0	Coulomb counter QCOUNT low alert limit, same format as QCOUNT (0x13)	0x0000	59
QCOUNT_HI_ALERT_LIMIT	0x11	R/W	15:0	Coulomb counter QCOUNT high alert limit, same format as QCOUNT (0x13)	0x0000	59
QCOUNT_PRESCALE_FACTOR	0x12	R/W	15:0	Coulomb counter prescale factor	0x0200	59
QCOUNT	0x13	R/W	15:0	Coulomb counter value	0x8000	59
CONFIG_BITS	0x14	R/W	15:0	Configuration Settings	0x0000	59
suspend_charger	0x14	R/W	8	suspend battery charger operation	0	59
run_bsr	0x14	R/W	5	perform a battery series resistance measurement	0	59
force_meas_sys_on	0x14	R/W	4	force measurement system to operate	0	59
mppt_en_i2c	0x14	R/W	3	enable maximum power point tracking	0	59
en_qcount	0x14	R/W	2	enable coulomb counter	0	59
IIN_LIMIT_SETTING	0x15	R/W	5:0	Input current limit setting = $(IIN_LIMIT_SETTING + 1) \cdot 500\mu V / R_{SNSI}$	0x3F	60
VIN_UVCL_SETTING	0x16	R/W	7:0	UVCLFB input undervoltage limit = $(VIN_UVCL_SETTING + 1) \cdot 4.6875mV$	0xFF	60
RESERVED	0x17					
RESERVED	0x18					
ARM_SHIP_MODE	0x19	R/W	15:0	Write 0x534D to arm ship mode. Once armed, ship mode cannot be disarmed.	0x0000	60
ICHARGE_TARGET	0x1A	R/W ²	4:0	Maximum charge current target = $(ICHARGE_TARGET + 1) \cdot 1mV/R_{SNSB}$	See Note 1	60
VCHARGE_SETTING	0x1B	R/W ²	5:0	Charge voltage target. See detailed description for equations.	See Note 1	60
C_OVER_X_THRESHOLD	0x1C	R/W ²	15:0	Two's complement Low IBAT threshold for C/x termination	See Note 1	61
MAX_CV_TIME	0x1D	R/W ²	15:0	Time in seconds with battery charger in the CV state before timer termination occurs (lithium chemistries only)	See Note 1	62
MAX_CHARGE_TIME	0x1E	R/W ²	15:0	Time in seconds before a max_charge_time fault is declared. Set to zero to disable max_charge_time fault	See Note 1	62
JEITA_T1	0x1F	R/W ²	15:0	Value of NTC_RATIO for transition between JEITA regions 2 and 1 (off)	0x3F00	62

REGISTER DESCRIPTION

SYMBOL	SUB ADDR	R/W	ACTIVE BITS	DESCRIPTION	DEFAULT	PAGE
JEITA_T2	0x20	R/W ²	15:0	Value of NTC_RATIO for transition between JEITA regions 3 and 2	0x372A	62
JEITA_T3	0x21	R/W ²	15:0	Value of NTC_RATIO for transition between JEITA regions 4 and 3	0x1F27	62
JEITA_T4	0x22	R/W ²	15:0	Value of NTC_RATIO for transition between JEITA regions 5 and 4	0x1BCC	62
JEITA_T5	0x23	R/W ²	15:0	Value of NTC_RATIO for transition between JEITA regions 6 and 5	0x18B9	62
JEITA_T6	0x24	R/W ²	15:0	Value of NTC_RATIO for transition between JEITA regions 7 (off) and 6	0x136D	62
VCHARGE_JEITA_6_5	0x25	R/W ²	9:0	VCHARGE values for JEITA temperature regions 6 and 5	See Note 1	62
vcharge_jeita_6			9:5			63
vcharge_jeita_5			4:0			63
VCHARGE_JEITA_4_3_2	0x26	R/W ²	14:0	VCHARGE values for JEITA temperature regions 4, 3, and 2	See Note 1	62
vcharge_jeita_4			14:10			63
vcharge_jeita_3			9:5			63
vcharge_jeita_2			4:0			63
ICHARGE_JEITA_6_5	0x27	R/W ²	9:0	ICHARGE_TARGET values for JEITA temperature regions 6 and 5	0x01EF	63
icharge_jeita_6			9:5		0x0F	63
icharge_jeita_5			4:0		0x0F	63
ICHARGE_JEITA_4_3_2	0x28	R/W ²	14:0	ICHARGE_TARGET value for JEITA temperature regions 4, 3, and 2	0x7FEF	63
icharge_jeita_4			14:10		0x1F	63
icharge_jeita_3			9:5		0x1F	63
icharge_jeita_2			4:0		0x0F	63
CHARGER_CONFIG_BITS	0x29	R/W ²	2:0	Battery charger configuration settings, bits 15:3 are reserved.	See Note 1	63
en_c_over_x_term			2	enable C/x termination	See Note 1	63
en_lead_acid_temp_comp			1	enable lead-acid charge voltage temperature compensation	See Note 1	63
en_jeita			0	enable jeita temperature profile	See Note 1	63
VABSORB_DELTA	0x2A	R/W ²	5:0	LiFePO ₄ /lead-acid absorb voltage adder, bits 15:6 are reserved.	See Note 1	61
MAX_ABSORB_TIME	0x2B	R/W ²	15:0	Maximum time for LiFePO ₄ /lead-acid absorb charge	See Note 1	62
VEQUALIZE_DELTA	0x2C	R/W ²	5:0	Lead-acid equalize charge voltage adder, bits 15:6 are reserved.	0x002A	61
EQUALIZE_TIME	0x2D	R/W ²	15:0	Lead-acid equalization time	0x0E10	62
LIFEP04_RECHARGE_THRESHOLD	0x2E	R/W	15:0	LiFePO ₄ recharge threshold	0x4410	62
RESERVED	0x2F					
MAX_CHARGE_TIMER	0x30	R	15:0	For lithium chemistries, indicates the time (in sec) that the battery has been charging		64
CV_TIMER	0x31	R	15:0	For lithium chemistries, indicates the time (in sec) that the battery has been in constant-voltage regulation		64
ABSORB_TIMER	0x32	R	15:0	For LiFePO ₄ and lead-acid batteries, indicates the time (in sec) that the battery has been in absorb phase		64
EQUALIZE_TIMER	0x33	R	15:0	For lead-acid batteries, indicates the time (in sec) that the battery has been in EQUALIZE phase		64

REGISTER DESCRIPTIONS

SYMBOL	SUB ADDR	R/W	ACTIVE BITS	DESCRIPTION	DEFAULT	PAGE
CHARGER_STATE	0x34	R	15:0	Real time battery charger state indicator. Individual bits are mutually exclusive. Bits 15:11 are reserved.		64
equalize_charge			10	indicates battery charger is in lead-acid equalization charge state		64
absorb_charge			9	indicates battery charger is in absorb charge state		64
charger_suspended			8	indicates battery charger is in charger suspended state		64
precharge			7	indicates battery charger is in precondition charge state		64
cc_cv_charge			6	indicates battery charger is in constant-current constant-voltage state		64
ntc_pause			5	indicates battery charger is in thermistor pause state		65
timer_term			4	indicates battery charger is in timer termination state		65
c_over_x_term			3	indicates battery charger is in C/x termination state		65
max_charge_time_fault			2	indicates battery charger is in max_charge_time_fault state		65
bat_missing_fault			1	indicates battery charger is in missing battery fault state		65
bat_short_fault			0	indicates battery charger is in shorted battery fault state		65
CHARGE_STATUS	0x35	R	15:0	Charge status indicator. Individual bits are mutually exclusive. Only active in charging states.		65
vin_uvcl_active			3	indicates the input undervoltage control loop is actively controlling power delivery based on VIN_UVCL_SETTING (0x16)		65
iin_limit_active			2	indicates the input current limit control loop is actively controlling power delivery based on IIN_LIMIT_DAC (0x46)		65
constant_current			1	indicates the charge current control loop is actively controlling power delivery based on ICHARGE_DAC (0x44)		65
constant_voltage			0	indicates the battery voltage control loop is actively controlling power delivery based on VCHARGE_DAC (0x45)		65
LIMIT_ALERTS	0x36	R	15:0	Limit alert register. Individual bits are enabled by EN_LIMIT_ALERTS (0x0D). Writing 0 to any bit clears that alert. Once set, alert bits remain high until cleared or disabled.		65
meas_sys_valid_alert			15	indicates that measurement system results have become valid.		66
qcount_lo_alert			13	indicates QCOUNT has fallen below QCOUNT_LO_ALERT_LIMIT (0x10)		66
qcount_hi_alert			12	indicates QCOUNT has exceeded QCOUNT_HI_ALERT_LIMIT (0x11)		66
vbat_lo_alert			11	indicates VBAT has fallen below VBAT_LO_ALERT_LIMIT (0x01)		66
vbat_hi_alert			10	indicates VBAT has exceeded VBAT_HI_ALERT_LIMIT (0x02)		66
vin_lo_alert			9	indicates VIN has fallen below VIN_LO_ALERT_LIMIT (0x03)		66
vin_hi_alert			8	indicates VIN has exceeded VIN_HI_ALERT_LIMIT (0x04)		66
vsys_lo_alert			7	indicates VSYS has fallen below VSYS_LO_ALERT_LIMIT (0x05)		66
vsys_hi_alert			6	indicates VSYS has exceeded VIN_HI_ALERT_LIMIT (0x06)		66
iin_hi_alert			5	indicates IIN has exceeded IIN_HI_ALERT_LIMIT (0x07)		66
ibat_lo_alert			4	indicates IBAT has fallen below IBAT_LO_ALERT_LIMIT (0x08)		66
die_temp_hi_alert			3	indicates DIE_TEMP has exceeded DIE_TEMP_HI_ALERT_LIMIT (0x09)		67
bsr_hi_alert			2	indicates BSR has exceeded BSR_HI_ALERT_LIMIT (0x0A)		67

REGISTER DESCRIPTIONS

SYMBOL	SUB ADDR	R/W	ACTIVE BITS	DESCRIPTION	DEFAULT	PAGE
ntc_ratio_hi_alert			1	indicates NTC_RATIO has exceeded NTC_RATIO_HI_ALERT_LIMIT (cold battery; 0x0B)		67
ntc_ratio_lo_alert			0	indicates NTC_RATIO has exceeded NTC_RATIO_LO_ALERT_LIMIT (hot battery; 0x0C)		67
CHARGER_STATE_ALERTS	0x37	R	15:0	Charger state alert register. Individual bits are enabled by EN_CHARGER_STATE_ALERTS (0x0E). Writing 0 to any bit clears that alert. Once set, alert bits remain high until cleared or disabled.		67
equalize_charge_alert			10	alert indicates charger has entered lead-acid equalize_charge state (0x34)		67
absorb_charge_alert			9	alert indicates charger has entered absorb_charge state (0x34)		67
charger_suspended_alert			8	alert indicates charger has entered charger_suspended(off) state (0x34)		67
precharge_alert			7	alert indicates charger has entered precharge charge state (0x34)		67
cc_cv_charge_alert			6	alert indicates charger has entered cc_cv_charge state (constant-current constant-voltage; 0x34)		67
ntc_pause_alert			5	alert indicates charger has entered ntc_pause state (0x34)		67
timer_term_alert			4	alert indicates charger has entered timer_term state (0x34)		67
c_over_x_term_alert			3	alert indicates charger has entered c_over_x term state (C/x termination; 0x34)		67
max_charge_time_fault_alert			2	alert indicates charger has entered max_charge_time_fault state (0x34)		68
bat_missing_fault_alert			1	alert indicates charger has entered bat_missing_fault state (0x34)		68
bat_short_fault_alert			0	alert indicates charger has entered bat_short_fault state (0x34)		68
CHARGE_STATUS_ALERTS	0x38	R	5:0	Alerts that CHARGE_STATUS indicators have occurred Individual bits are enabled by EN_CHARGE_STATUS_ALERTS (0x0F) Writing 0 to any bit clears that alert. Once set, alert bits remain high until cleared or disabled.		68
vin_uvcl_active_alert			3	alert indicates vin_uvcl_active state entered (V_{IN} undervoltage current limit, 0x35)		68
iin_limit_active_alert			2	alert indicates iin_limit_active state entered (V_{IN} current limit; 0x35)		68
constant_current_alert			1	alert indicates constant_current state entered (0x35)		68
constant_voltage_alert			0	alert indicates constant_voltage state entered (0x35)		68
SYSTEM_STATUS	0x39	R	15:0	Real time system status indicator bits		68
charger_enabled			13	indicates that the battery charger is active		68
mppt_en_pin			11	indicates the mppt_en pin is set to enable maximum power point tracking		68
equalize_req			10	indicates a rising edge has been detected at the EQ pin, and an lead-acid equalize charge is queued		68
drvcc_good			9	indicates DRV_{CC} voltage is above switching charger undervoltage lockout level (4.3V typical)		69
cell_count_error			8	indicates an invalid combination of CELLS pin settings		69
ok_to_charge			6	indicates all system conditions are met to allow battery charger operation		69
no_rt			5	indicates no resistor has been detected at the rt pin		69
thermal_shutdown			4	indicates die temperature is greater than thermal shutdown level (160°C typical)		69

REGISTER DESCRIPTIONS

SYMBOL	SUB ADDR	R/W	ACTIVE BITS	DESCRIPTION	DEFAULT	PAGE
vin_ovlo			3	indicates vin voltage is greater than overvoltage lockout level (38.6V typical)		69
vin_gt_vbat			2	indicates vin voltage is sufficiently greater than batsens for switching charger operation (200mV typical)		69
intvcc_gt_4p3v			1	indicates INTV _{CC} voltage is above switching charger undervoltage lockout level (4.3V typ)		69
intvcc_gt_2p8v			0	indicates INTV _{CC} voltage is greater than measurement system lockout level (2.8V typical)		69
VBAT	0x3A	R	15:0	Two's complement ADC measurement result for the BATSENS pin. $V_{BATSENS}/\text{cellcount} = [\text{VBAT}] \cdot 192.264\mu\text{V}$ for lithium chemistries. $V_{BATSENS}/\text{cellcount} = [\text{VBAT}] \cdot 128.176\mu\text{V}$ for lead-acid.		69
VIN	0x3B	R	15:0	Two's complement ADC measurement result for V _{IN} . $V_{VIN} = [\text{VIN}] \cdot 1.648\text{mV}$		69
VSYS	0x3C	R	15:0	Two's complement ADC measurement result for V _{SYS} . $V_{SYS} = [\text{VSYS}] \cdot 1.648\text{mV}$		69
IBAT	0x3D	R	15:0	Two's complement ADC measurement result for (V _{CSP} – V _{CSN}). Charge current (into the battery) is represented as a positive number. Battery current = [IBAT] • 1.46487μV/R _{SNSB}		69
IIN	0x3E	R	15:0	Two's complement ADC measurement result for (V _{CLP} – V _{CLN}). Input current = [IIN] • 1.46487μV/R _{SNSI}		70
DIE_TEMP	0x3F	R	15:0	Two's complement ADC measurement result for die temperature. Temperature = (DIE_TEMP – 12010)/45.6°C		70
NTC_RATIO	0x40	R	15:0	Two's complement ADC measurement result for NTC thermistor ratio. $R_{NTC} = \text{NTC_RATIO} \cdot R_{NTCBIAS}/(21845.0 - \text{NTC_RATIO})$		70
BSR	0x41	R	15:0	Calculated battery series resistance. For lithium chemistries, series resistance/cellcount = BSR • R _{SNSB} /500.0 For lead-acid chemistries, series resistance/cellcount = BSR • R _{SNSB} /750.0		70
JEITA_REGION	0x42	R	2:0	JEITA temperature region of the NTC thermistor (Li Only). Active only when EN_JEITA=1		70
CHEM_CELLS	0x43	R	11:0	Readout of CHEM and CELLS pin settings		70
chem			11:8	programmed battery chemistry		70
reserved			7:4	Reserved		
cell_count_pins			3:0	cell count as set by CELLS pins		70
ICHARGE_DAC	0x44	R	4:0	Charge current control DAC control bits		71
VCHARGE_DAC	0x45	R	5:0	Charge voltage control DAC control bits		71
IIN_LIMIT_DAC	0x46	R	5:0	Input current limit control DAC control word		71
VBAT_FILT	0x47	R	15:0	Digitally filtered two's complement ADC measurement result for battery voltage		71
ICHARGE_BSR	0x48	R	15:0	This 16-bit two's complement word is the value of IBAT (0x3D) used in calculating BSR.		71
RESERVED	0x49					
MEAS_SYS_VALID	0x4A	R	0	Measurement valid bit, bit 0 is a 1 when the telemetry(ADC) system is ready		71

Notes:

- Some defaults are chemistry dependant. See the detailed register descriptions for more information.
- Charger setting registers (sub-addresses 0x1A through 0x2D) are only writable if the CHEM pins are configured for a programmable chemistry option. If the CHEM pins are configured for a fixed chemistry option, the charger setting registers are read only.

DETAILED REGISTER DESCRIPTIONS

VBAT_LO_ALERT_LIMIT (Sub-Address 0x01, Bits 15:0, R/W),

VBAT_HI_ALERT_LIMIT (Sub-Address 0x02, Bits 15:0, R/W)

These 16-bit words set upper and lower limits that can be used to trigger an SMBALERT based on the BATSENS pin voltage out of range. The values use the same two's complement format as VBAT. For lithium chemistries, BATSENS/cellcount voltage HI/LO alert limit = $[\text{VBAT_xx_ALERT_LIMIT}] \cdot 192.264\mu\text{V}$. For lead-acid batteries, BATSENS/cellcount voltage HI/LO alert limit = $[\text{VBAT_xx_ALERT_LIMIT}] \cdot 128.176\mu\text{V}$

VIN_LO_ALERT_LIMIT (Sub-Address 0x03, Bits 15:0, R/W),

VIN_HI_ALERT_LIMIT (Sub-Address 0x04, Bits 15:0, R/W)

These 16-bit words set upper and lower limits that can be used to trigger an SMBALERT based on input voltage at the V_{IN} pin out of range. The values use the same two's complement format as VIN. Input voltage HI/LO alert limit = $[\text{VIN_xx_ALERT_LIMIT}] \cdot 1.648\text{mV}$.

VSYS_LO_ALERT_LIMIT (Sub-Address 0x05, Bits 15:0, R/W),

VSYS_HI_ALERT_LIMIT (Sub-Address 0x06, Bits 15:0, R/W)

These 16-bit words set upper and lower limits that can be used to trigger an SMBALERT based on system voltage at the SYS pin out of range. The values use the same two's complement format as VSYS. System voltage HI/LO alert limit = $[\text{VSYS_xx_ALERT_LIMIT}] \cdot 1.648\text{mV}$.

IIN_HI_ALERT_LIMIT (Sub-Address 0x07, Bits 15:0, R/W)

This 16-bit word sets an upper limit that can be used to trigger an SMBALERT based on input current above a certain value. IIN_HI_ALERT_LIMIT uses the same two's complement format as IIN. Input current high alert limit = $[\text{IIN_HI_ALERT_LIMIT}] \cdot 1.46487\mu\text{V}/R_{\text{SNSI}}$.

IBAT_LO_ALERT_LIMIT (Sub-Address 0x08, Bits 15:0, R/W)

This 16-bit word sets an upper limit that can be used to trigger an SMBALERT based on charge current below a certain value. IBAT_LO_ALERT_LIMIT uses the same two's complement format as IBAT with battery discharge current being negative. Battery current low alert limit = $[\text{IBAT_LO_ALERT_LIMIT}] \cdot 1.46487\mu\text{V}/R_{\text{SNSB}}$.

DIE_TEMP_HI_ALERT_LIMIT (Sub-Address 0x09, Bits 15:0, R/W)

This 16-bit word sets an upper limit that can be used to trigger an SMBALERT based on high die temperature. DIE_TEMP_HI_ALERT_LIMIT uses the same two's complement format as DIE_TEMP. LTC4015 temperature = $(\text{DIE_TEMP} - 12010)/45.6^\circ\text{C}$

BSR_HI_ALERT_LIMIT (Sub-Address 0x0A, Bits 15:0, R/W)

This 16-bit word sets an upper limit that can be used to trigger an SMBALERT based on high battery series resistance. BSR_HI_ALERT_LIMIT uses the same format as BSR. The battery series resistance is a function of R_{SNSB} , and can be computed as $\Omega/\text{cellcount} = [\text{BSR}/500] \cdot R_{\text{SNSB}}$ (lithium chemistries), or $\Omega/\text{cellcount} = [\text{BSR}/750] \cdot R_{\text{SNSB}}$ (lead-acid).

NTC_RATIO_HI_ALERT_LIMIT (Sub-Address 0x0B, Bits 15:0, R/W),

NTC_RATIO_LO_ALERT_LIMIT (Sub-Address 0x0C, Bits 15:0, R/W)

These 16-bit words set upper and lower limits that can be used to trigger an SMBALERT based on thermistor value out of range. The values use the same two's complement format as NTC_RATIO. The thermistor value can be determined by the expression $R_{\text{NTC}} = R_{\text{NTCBIAS}} \cdot \text{NTC_RATIO}/(21,845 - \text{NTC_RATIO})$. Recall that the thermistor has a negative temperature coefficient so higher temperatures correspond to lower NTC_RATIO readings and vice-versa. Thus, NTC_RATIO_HI_ALERT_LIMIT sets an upper alert limit for the value of NTC_RATIO which corresponds to a low (cold) temperature for the thermistor, and NTC_RATIO_LO_ALERT_LIMIT sets a lower alert limit for the value of NTC_RATIO which corresponds to a high (hot) temperature for the thermistor.

DETAILED REGISTER DESCRIPTIONS

EN_LIMIT_ALERTS (Sub-Address 0x0D, Bits 15:0, R/W)

This register consists of individual limit alert enable bits. These bits enable monitoring and notification of limit excursions via SMBALERT and the LIMIT_ALERTS (0x36) register. See the section Programmable Alerts and Interrupt Controller for more information.

en_meas_sys_valid_alert (Sub-Address 0x0D, Bit 15, R/W)

To achieve high measurement accuracy, the measurement system in the LTC4015 has a nominal warm up time of approximately 12ms. Setting this alert enable bit causes an SMBALERT when the measurement system indicates its results are valid. Note that the LTC4015 switching charger will not operate until the measurement system warm up period has passed, regardless of the state of en_meas_sys_valid_alert.

en_qcount_lo_alert (Sub-Address 0x0D, Bit 13, R/W)

Setting this enable bit causes an SMBALERT when QCOUNT has fallen below QCOUNT_LO_ALERT_LIMIT. qcount_lo_alert is set to 1 by the LTC4015 if the alert occurs.

en_qcount_hi_alert (Sub-Address 0x0D, Bit 12, R/W)

Setting this enable bit causes an SMBALERT when QCOUNT has exceeded QCOUNT_HI_ALERT_LIMIT. qcount_hi_alert is set to 1 by the LTC4015 if the alert occurs.

en_vbat_lo_alert (Sub-Address 0x0D, Bit 11, R/W)

Setting this enable bit causes an SMBALERT when VBAT has fallen below VBAT_LO_ALERT_LIMIT. vbat_lo_alert is set to 1 by the LTC4015 if the alert occurs.

en_vbat_hi_alert (Sub-Address 0x0D, Bit 10, R/W)

Setting this enable bit causes an SMBALERT when VBAT has exceeded VBAT_HI_ALERT_LIMIT. vbat_hi_alert is set to 1 by the LTC4015 if the alert occurs.

en_vin_lo_alert (Sub-Address 0x0D, Bit 9, R/W)

Setting this enable bit causes an SMBALERT when VIN has fallen below VIN_LO_ALERT_LIMIT. vin_lo_alert is set to 1 by the LTC4015 if the alert occurs.

en_vin_hi_alert (Sub-Address 0x0D, Bit 8, R/W)

Setting this enable bit causes an SMBALERT when VIN has exceeded VIN_HI_ALERT_LIMIT. vin_hi_alert is set to 1 by the LTC4015 if the alert occurs.

en_vsys_lo_alert (Sub-Address 0x0D, Bit 7, R/W)

Setting this enable bit causes an SMBALERT when VSYS has fallen below VSYS_LO_ALERT_LIMIT. vsys_lo_alert is set to 1 by the LTC4015 if the alert occurs.

en_vsys_hi_alert (Sub-Address 0x0D, Bit 6, R/W)

Setting this enable bit causes an SMBALERT when VSYS has exceeded VSYS_HI_ALERT_LIMIT. vsys_hi_alert is set to 1 by the LTC4015 if the alert occurs.

en_iin_hi_alert (Sub-Address 0x0D, Bit 5, R/W)

Setting this enable bit causes an SMBALERT when IIN has exceeded IIN_HI_ALERT_LIMIT. iin_hi_alert is set to 1 by the LTC4015 if the alert occurs.

DETAILED REGISTER DESCRIPTIONS

en_ibat_lo_alert (Sub-Address 0x0D, Bit 4, R/W)

Setting this enable bit causes an SMBALERT when IBAT has fallen below IBAT_LO_ALERT_LIMIT. `ibat_lo_alert` is set to 1 by the LTC4015 if the alert occurs.

en_die_temp_hi_alert (Sub-Address 0x0D, Bit 3, R/W)

Setting this enable bit causes an SMBALERT when DIE_TEMP has exceeded DIE_TEMP_HI_ALERT_LIMIT. `die_temp_hi_alert` is set to 1 by the LTC4015 if the alert occurs.

en_bsr_hi_alert (Sub-Address 0x0D, Bit 2, R/W)

Setting this enable bit causes an SMBALERT when BSR has exceeded BSR_HI_ALERT_LIMIT. `bsr_hi_alert` is set to 1 by the LTC4015 if the alert occurs.

en_ntc_ratio_hi_alert (Sub-Address 0x0D, Bit 1, R/W)

Setting this enable bit causes an SMBALERT when NTC_RATIO has exceeded NTC_RATIO_HI_ALERT_LIMIT (cold battery). Recall that the thermistor has a negative temperature coefficient so higher temperatures correspond to lower NTC_RATIO readings and vice-versa. `ntc_ratio_hi_alert` is set to 1 by the LTC4015 if the alert occurs.

en_ntc_ratio_lo_alert (Sub-Address 0x0D, Bit 0, R/W)

Setting this enable bit causes an SMBALERT when NTC_RATIO has fallen below NTC_RATIO_LO_ALERT_LIMIT (hot battery). Recall that the thermistor has a negative temperature coefficient so higher temperatures correspond to lower NTC_RATIO readings and vice-versa. `ntc_ratio_lo_alert` is set to 1 by the LTC4015 if the alert occurs.

EN_CHARGER_STATE_ALERTS (Sub-Address 0x0E, Bits 10:0, R/W)

This register consists of individual charger state alert enable bits, which enable notification via SMBALERT based on the phase of a battery charge cycle. See the CHARGER_STATE (0x37) register details and the sections Battery Charger Algorithms and Programmable Alerts and Interrupt Controller for more information.

en_equalize_charge_alert (Sub-Address 0x0E, Bit 10, R/W)

Setting this enable bit causes an SMBALERT when the LTC4015 is in the equalize phase of a battery charge cycle (`equalize_charge=1`, applies to lead-acid chemistries only).

en_absorb_charge_alert (Sub-Address 0x0E, Bit 9, R/W)

Setting this enable bit causes an SMBALERT when the LTC4015 is in the absorb phase of a battery charge cycle (`absorb_charge=1`, applies to LiFePO₄ and lead-acid chemistries only).

en_charger_suspended_alert (Sub-Address 0x0E, Bit 8, R/W)

Setting this enable bit causes an SMBALERT when the LTC4015 charger is suspended (`charger_suspended=1`).

en_precharge_alert (Sub-Address 0x0E, Bit 7, R/W)

Setting this enable bit causes an SMBALERT when the LTC4015 is in precondition charge phase of a battery charge cycle (`precharge=1`) due to the battery being below the low battery threshold of 2.9V/cell (applies to Li-Ion chemistries only).

en_cc_cv_charge_alert (Sub-Address 0x0E, Bit 6, R/W)

Setting this enable bit causes an SMBALERT when the LTC4015 is in the CC-CV phase of a battery charge cycle (`cc_cv_charge=1`).

DETAILED REGISTER DESCRIPTIONS

en_ntc_pause_alert (Sub-Address 0x0E, Bit 5, R/W)

Setting this enable bit causes an SMBALERT when the LTC4015 is in thermistor pause state (`ntc_pause=1`) due to `NTC_RATIO` out of range as set by the `JEITA_T1` and `JEITA_T6` values. See the section J.E.I.T.A. Temperature Qualified Charging (applies to lithium chemistries only).

en_timer_term_alert (Sub-Address 0x0E, Bit 4, R/W)

Setting this enable bit causes an SMBALERT when the LTC4015 is in timer termination state (`timer_term=1`) due to battery being at V_{CHARGE} for more than `MAX_CHARGE_TIME` (applies to lithium chemistries only).

en_c_over_x_term_alert (Sub-Address 0x0E, Bit 3, R/W)

Setting this enable bit causes an SMBALERT when the LTC4015 is in C/x termination state (`c_over_x_term=1`) due to `IBAT` dropping below `C_OVER_X_THRESHOLD` (applies to lithium chemistries only).

en_max_charge_time_fault_alert (Sub-Address 0x0E, Bit 2, R/W)

Setting this enable bit causes an SMBALERT when the LTC4015 is in max charge time fault (`max_charge_time_fault = 1`) due to `MAX_CHARGE_TIMER` exceeding `MAX_CHARGE_TIME` during a charge cycle (applies to lithium chemistries only).

en_bat_missing_fault_alert (Sub-Address 0x0E, Bit 1, R/W)

Setting this enable bit causes an SMBALERT if the LTC4015 is in battery missing fault state (`bat_missing_fault=1`) due to no battery detected.

en_bat_short_fault_alert (Sub-Address 0x0E, Bit 0, R/W)

Setting this enable bit causes an SMBALERT if the LTC4015 is in shorted battery fault state (`bat_short_fault=1`) because the battery was determined to be shorted during the battery detection phase at the beginning of a charge cycle.

EN_CHARGE_STATUS_ALERTS (Sub-Address 0x0F, Bits 3:0, R/W)

This register consists of individual charge status alert enable bits, which enable notification via SMBALERT based on the status of the battery charge current control circuitry. See the `CHARGE_STATUS` register details and the section Programmable Alerts and Interrupt Controller for more information.

en_vin_uvcl_active_alert (Sub-Address 0x0F, Bit 3, R/W)

Setting this enable bit causes an SMBALERT when the UVCL undervoltage current limit regulation loop of the LTC4015 is in control of the switching CHARGER current delivery (`vin_uvcl_active=1`).

en_iin_limit_active_alert (Sub-Address 0x0F, Bit 2, R/W)

Setting this enable bit causes an SMBALERT when the input current regulation loop of the LTC4015 is in control of the switching CHARGER current delivery (`iin_limit_active=1`).

en_constant_current_alert (Sub-Address 0x0F, Bit 1, R/W)

Setting this enable bit causes an SMBALERT when the battery charge current regulation loop of the LTC4015 is in control of the switching CHARGER current delivery (`constant_current=1`).

en_constant_voltage_alert (Sub-Address 0x0F, Bit 0, R/W)

Setting this enable bit causes an SMBALERT when the battery voltage regulation loop of the LTC4015 is in control of the switching CHARGER current delivery (`constant_voltage=1`).

DETAILED REGISTER DESCRIPTIONS

QCOUNT_LO_ALERT_LIMIT (Sub-Address 0x10, Bits 15:0, R/W)

QCOUNT_HI_ALERT_LIMIT (Sub-Address 0x11, Bits 15:0, R/W)

These 16-bit words set and lower and upper limits on QCOUNT that can be used to trigger an SMBALERT when QCOUNT falls below QCOUNT_LO_ALERT_LIMIT, or QCOUNT exceeds QCOUNT_HI_ALERT_LIMIT. The values use the same format as QCOUNT.

QCOUNT_PRESCALE_FACTOR (Sub-Address 0x12, Bits 15:0, R/W)

This 16-bit word along with R_{SNSB} is used to set the q_{LSB} value of Coulomb counter accumulator, QCOUNT.

$$q_{LSB} = \frac{QCOUNT_PRESCALE_FACTOR}{8333.33 \cdot R_{SNSB}} A \cdot s(COULOMBS)$$

QCOUNT (Sub-Address 0x13, Bits 15:0, R/W)

This 16-bit word reports the current value of Coulomb counter accumulator, QCOUNT. This register can be written to represent a known state of charge of the battery.

$$q_{LSB} = \frac{QCOUNT_PRESCALE_FACTOR}{8333.33 \cdot R_{SNSB}} A \cdot s(COULOMBS)$$

CONFIG_BITS (Sub-Address 0x14, Bits 8:0, R/W)

This register consists of individual system configuration bits which control various features of the LTC4015.

suspend_charger (Sub-Address 0x14, Bit 8, R/W)

Setting this bit causes battery charging to be suspended, and forces `charger_suspended=1`. A new battery charge cycle can be forced by setting and then resetting `suspend_charger`.

run_bsr (Sub-Address 0x14, Bit 5, R/W)

Setting this bit causes a single battery series resistance (BSR) measurement to be made by the LTC4015. Once the series resistance measurement is complete, the LTC4015 resets the `run_bsr` bit to 0, and the result is reported as `BSR`. `ICHARGE_BSR` is the value of `IBAT` that was used in the BSR calculation. See the section Battery Series Resistance Measurement.

force_meas_sys_on (Sub-Address 0x14, Bit 4, R/W)

Setting this bit causes the A/D measurement system to operate at all times, including when input power is unavailable (`vin_gt_vbat=0`). This feature is disabled by default in order to reduce battery-only load current. Setting this bit has the advantage of maintaining up-to-date system data, but will increase battery drain.

When input power is absent, the measurement system can be sampled periodically to reduce quiescent current. See the Measurement Subsystem description for details.

mppt_en_i2c (Sub-Address 0x14, Bit 3, R/W)

Setting this bit causes the maximum power point tracking algorithm to run when the switching charger is active. The maximum power point algorithm uses the UVCL regulation loop to seek the optimum power point for resistive sources such as a solar panel. See the section maximum power point tracking for more information. The maximum power point algorithm can also be enabled by connecting the MPPT pin to the $2P5V_{CC}$ pin. The `mppt_en_i2c` bit is logically ORed with the MPPT pin. To disable MPPT both the `mppt_en_i2c` bit and the MPPT pin must be low.

en_qcount (Sub-Address 0x14, Bit 2, R/W)

Setting this bit enables the LTC4015 Coulomb counter. This feature is disabled by default to reduce quiescent current.

DETAILED REGISTER DESCRIPTIONS

IIN_LIMIT_SETTING (Sub-Address 0x15, Bits 5:0, R/W)

These 6 bits control the target input current limit setting. The input current will be regulated to a maximum value given by $(IIN_LIMIT_SETTING + 1) \cdot 500\mu V/R_{SNSI}$.

VIN_UVCL_SETTING (Sub-Address 0x16, Bits 7:0, R/W)

These 8 bits control the UVCLFB regulation loop servo voltage. The UVCLFB regulation voltage is given by $(VIN_UVCL_SETTING + 1) \cdot 4.6875mV$. By default, this register is set to full-scale (0xFF), corresponding to 1.2V at UVCLFB pin. If enabled, the maximum power point tracking (MPPT) algorithm directly manipulates VIN_UVCL_SETTING.

ARM_SHIP_MODE (Sub-Address 0x19, Bits 15:0, R/W)

Setting this register to 0x534D (ASCII for SM) arms LTC4015's low power ship mode. The only allowed values for this register are 0x0000 and 0x534D, and once armed, ship mode cannot be disarmed (writing ARM_SHIP_MODE=0 does not disarm ship mode). Ship mode does not take effect until V_{IN} drops below approximately 1V. See the section Low Power Ship Mode.

CHARGER SETTING REGISTER DESCRIPTIONS (Sub-Addresses 0x1A through 0x2E)

Registers which control the primary charging parameters, such as charge voltage and charge current are only writable when the CHEMn pins are configured for a programmable chemistry algorithm (Li-Ion-Prog, LiFePO₄-Prog, or Lead-Acid-Prog). If the CHEMn pins are configured for a fixed chemistry algorithm (Li-Ion-Fixed-4.2, Li-Ion-Fixed-4.1, Li-Ion-fixed-4.0, LiFePO₄-Fixed-3.6, LiFePO₄-Fixed-3.8/3.6, or Lead-Acid-Fixed) the LTC4015 ignores writes to these registers. See the section Chemistry Selection for more information about configuring the CHEMn pins.

ICHARGE_TARGET (Sub-Address 0x1A, bits 4:0, Fixed: R, Programmable: R/W)

This register controls the target charge current regulation servo level for lead-acid batteries or if en_jeita=0 for lithium chemistries. For lithium chemistries, if en_jeita=1 (default) ICHARGE_TARGET is controlled by ICHARGE_JEITA_n (see the section JEITA Temperature Controlled Charging). The charge current regulation servo level is generally given by $(ICHARGE_TARGET + 1) \times 1mV/R_{SNSB}$, except during Li-Ion precondition charge phase when the charge current regulation servo level is reduced by approximately a factor of 10 (rounded down to an increment of $1mV/R_{SNSB}$).

VCHARGE_SETTING (Sub-Address 0x1B, bits 5:0, Fixed: R, Programmable: R/W)

This register controls the charge voltage regulation servo level. The LTC4015 does not monitor or balance individual cells – the full battery stack voltage is divided by number of cells (V/cell) for simplicity only. The 4015 is not a substitute for pack protection!

For Li-Ion batteries, only the lower five bits (4:0) are active, and the charge voltage level is given by $(VCHARGE_SETTING/80.0 + 3.8125)V/cell$. If en_jeita=1, VCHARGE_SETTING is controlled by vcharge_jeita_n (see the section JEITA Temperature Qualified Charging). To maintain inherent over charge protection, the maximum Li-Ion charge voltage level is 4.2V/cell.

For LiFePO₄ batteries, only the lower five bits (4:0) are active, and the charge voltage level is given by $(VCHARGE_SETTING/80.0 + 3.4125)V/cell$. If en_jeita=1, VCHARGE_SETTING is controlled by vcharge_jeita_n (see the section JEITA Temperature Qualified Charging). To maintain inherent over-charge protection, the maximum LiFePO₄ charge voltage level is 3.8V/cell.

For lead-acid batteries, if en_lead_acid_temp_comp=1, the charge voltage level is given by $(VCHARGE_SETTING/105.0 + 2.0)V/cell$ at 25°C when a thermistor with a β value of 3490k is used. See the section Lead-Acid Temperature Compensated Charging for more information. If en_lead_acid_temp_comp=1, the value of VCHARGE_SETTING is limited to a maximum setting of 35, which corresponds to 2.333V/cell. If en_lead_acid_temp_comp=0, the charge

DETAILED REGISTER DESCRIPTIONS

voltage level is given by $(VCHARGE_SETTING/105.0 + 2.0)V/cell$, regardless of temperature. To maintain inherent over charge protection, the maximum lead-acid charge voltage level is 2.6 V/cell.

VABSORB_DELTA (Sub-Address 0x2A, bits 5:0, Fixed: R, Programmable: R/W)

This register controls the absorb adder voltage for LiFePO₄ and lead-acid batteries in absorb charge phase. The absorb charge phase battery voltage servo level is based on the sum of the absorb adder voltage and the charge voltage level.

For Li-Ion batteries, VABSORB_DELTA is ignored.

For LiFePO₄ batteries, only the lower five bits (4:0) are active, and the absorb voltage level is given by $(VABSORB_DELTA + VCHARGE_SETTING)/80 + 3.4125 V/cell$, limited to a maximum of 3.8 V/cell. Setting VABSORB_DELTA=0 disables the absorb phase. See the section LiFePO₄ Absorb Charge for more information.

For lead-acid batteries, if $en_lead_acid_temp_comp=1$, the absorb voltage level is given by $(VABSORB_DELTA + VCHARGE_SETTING)/105.0 + 2.0V/cell$ at 25°C when a thermistor with a β value of 3490k is used. See the section Lead-Acid Temperature Compensated Charging for more information. If $en_lead_acid_temp_comp=0$, the absorb voltage level is given by $(VABSORB_DELTA + VCHARGE_SETTING)/105.0 + 2.0V/cell$, regardless of temperature. To maintain inherent over charge protection, the maximum lead-acid absorb voltage level is 2.6 V/cell.

VEQUALIZE_DELTA (Sub-Address 0x2C, Bits 5:0, Fixed: R, Programmable: R/W)

These six bits control the equalize adder voltage for lead-acid batteries in equalize charge phase. The equalize charge phase battery voltage servo level is based on the sum of the equalize adder voltage and the vcharge level.

For lead-acid batteries, if $en_lead_acid_temp_comp=1$, the equalize voltage level is given by $(VEQUALIZE_DELTA + VCHARGE_SETTING) / 105.0 + 2.0 V/cell$ at 25°C when a typical curve two thermistor is used. See the section Lead-Acid Temperature Compensated Charging for more information. If $en_lead_acid_temp_comp=0$, the equalize voltage level is given by $((VEQUALIZE_DELTA + VCHARGE_SETTING)/105.0 + 2.0)V/cell$, regardless of temperature. To maintain inherent over charge protection, the maximum lead-acid equalize voltage level is 2.6V/cell.

For lithium chemistries, VEQUALIZE_DELTA is ignored.

C_OVER_X_THRESHOLD (Sub-Address 0x1C, Bits 15:0, Fixed: R, Programmable: R/W)

This 16-bit word sets the IBAT value used to qualify C/x detection for charge phase termination/transition. C_OVER_X_THRESHOLD uses the same format as IBAT, and the C/x current level is given by $C_OVER_X_THRESHOLD/(R_{SNSB} \cdot 21845.0/0.032V)$. The default value for C_OVER_X_THRESHOLD is 2184, which corresponds to 10% (3.2mV) of a 32mV/ R_{SNSB} full-scale charge current. C/x detection is disabled if C_OVER_X_THRESHOLD is set to zero.

For Li-Ion batteries, if $en_c_over_x_term=1$ (0 by default), C/x charge termination occurs after the battery reaches the charge voltage level and IBAT drops below C_OVER_X_THRESHOLD. See the section C/x Termination.

For LiFePO₄ batteries, if $en_c_over_x_term=1$ (0 by default), C/x charge termination occurs after the battery reaches vcharge level and IBAT drops below C_OVER_X_THRESHOLD during CC-CV charge phase. See the section C/x Termination. If the optional LiFePO₄ absorb charge phase is employed and if C_OVER_X_THRESHOLD is set to a non-zero value, the absorb phase ends if the battery voltage reaches absorb level and IBAT drops below C_OVER_X_THRESHOLD, and CC-CV phase begins. See the section LiFePO₄ Absorb Charge.

For lead-acid batteries, if C_OVER_X_THRESHOLD is non-zero, absorb charge phase ends after the battery voltage reaches absorb level and IBAT drops below C_OVER_X_THRESHOLD, and the CC-CV charge phase continues indefinitely.

DETAILED REGISTER DESCRIPTIONS

MAX_CV_TIME (Sub-Address 0x1D, Bits 15:0, Fixed: R, Programmable: R/W)

For lithium chemistries, this 16-bit word sets the termination time limit at one second per count. If the charger is in the CV state for MAX_CV_TIME seconds, timer termination occurs. The actual timer value is reported in CV_TIMER. See the section Timer Termination for more information. The default setting is four hours (14,400) for Li-Ion batteries and one hour (3,600) for LiFePO₄ batteries. For lead-acid batteries, MAX_CV_TIME is ignored.

MAX_ABSORB_TIME (Sub-Address 0x2B, Bits 15:0, Fixed: R, Programmable: R/W)

For LiFePO₄ and lead-acid batteries, this 16-bit word sets an upper limit on the time (at one second per count) that the battery can be in the absorb charge phase. The actual timer value is reported in ABSORB_TIMER. See the sections LiFePO₄ Absorb Charge and Lead-Acid Absorb Charge. For Li-Ion batteries, MAX_ABSORB_TIME is ignored.

EQUALIZE_TIME (Sub-Address 0x2D, Bits 15:0, Fixed: R, Programmable: R/W)

For lead-acid batteries, this 16-bit word sets the time (at one second per count) for the equalization charge phase. For lead-acid batteries, the default setting is 3600 seconds. See the section Lead-Acid Equalization Charge. For lithium chemistries, EQUALIZE_TIME is ignored.

MAX_CHARGE_TIME (Sub-Address 0x1E, Bits 15:0, Fixed: R, Programmable: R/W)

For lithium chemistries, this 16-bit word sets the max_charge_time fault detection time at one second per count. The default setting is 18.2 hours (65535). If the MAX_CHARGE_TIMER exceeds MAX_CHARGE_TIME during charging, a max charge time fault occurs. See the section Max Charge Time Fault for more information. For lead-acid batteries, MAX_CHARGE_TIME is ignored.

LIFEP04_RECHARGE_THRESHOLD (Sub-Address 0x2E, Bits 15:0, Fixed: R, Programmable: R/W)

In LiFePO₄ programmable mode only, this 16 bit two's complement word sets the recharge threshold, where the recharge threshold/cell = [LiFePO₄_RECHARGE_THRESHOLD] • 192.264μV. Default is 0x4410 which is 3.35V/cell.

JEITA_Tn (Sub-Address 0x1F Through 0x24, Bits 15:0, Fixed: R, Programmable: R/W)

(n = 1,2,3,4,5,6)

For lithium chemistries, these six 16-bit words set the JEITA temperature region break points T1 – T6, and have the same format as NTC_RATIO. The temperatures are based on the thermistor reading from the measurement system. Recall that the thermistor has a negative temperature coefficient so JEITA_T1, representing colder temperatures, will have the highest value and JEITA_T6, representing warmer temperatures, will have the lowest value. See the section JEITA Temperature Qualified Charging. JEITA_Tn are ignored for lead-acid batteries or if en_jeita=0.

Programming of JEITA Values

REGION 1	REGION 2	REGION 3	REGION 4	REGION 5	REGION 6	REGION 7
[JEITA_T1]	[JEITA_T2]	[JEITA_T3]	[JEITA_T4]	[JEITA_T5]	[JEITA_T6]	
CHARGER OFF	icharge_jeita_2	icharge_jeita_3	icharge_jeita_4	icharge_jeita_5	icharge_jeita_6	CHARGER OFF
	vcharge_jeita_2	vcharge_jeita_3	vcharge_jeita_4	vcharge_jeita_5	vcharge_jeita_6	

VCHARGE_JEITA_6_5 (Sub-Address 0x25, Bits 9:0, Fixed: R, Programmable: R/W),

VCHARGE_JEITA_4_3_2 (Sub-Address 0x26, Bits 14:0, Fixed: R, Programmable: R/W)

For lithium chemistries, these two registers contain the charge voltage settings to be used in the JEITA voltage vs temperature profile. VCHARGE_JEITA_6_5 contains two bit packed values, vcharge_jeita_6 (bits 9:5) and vcharge_jeita_5

DETAILED REGISTER DESCRIPTIONS

(bits 4:0). VCHARGE_JEITA_4_3_2 contains three bit packed values, vcharge_jeita_4 (bits 14:10), vcharge_jeita_3 (bits 9:5), and vcharge_jeita_2 (bits 4:0). These registers are ignored for lead-acid batteries or if en_jeita=0.

vcharge_jeita_n (n = 2,3,4,5,6)

These five 5-bit values set the VCHARGE_SETTING values to be used in each of the JEITA voltage vs temperature regions. There are no defined charge voltages for regions 1 and 7 because battery charging is paused in these regions. See the JEITA Temperature Qualified Charging section.

Programming of JEITA Values

REGION 1	REGION 2	REGION 3	REGION 4	REGION 5	REGION 6	REGION 7
[JEITA_T1]	[JEITA_T2]	[JEITA_T3]	[JEITA_T4]	[JEITA_T5]	[JEITA_T6]	
CHARGER OFF	icharge_jeita_2	icharge_jeita_3	icharge_jeita_4	icharge_jeita_5	icharge_jeita_6	CHARGER OFF
	vcharge_jeita_2	vcharge_jeita_3	vcharge_jeita_4	vcharge_jeita_5	vcharge_jeita_6	

ICHARGE_JEITA_6_5 (Sub-Address 0x27, Bits 9:0, Fixed: R, Programmable: R/W), ICHARGE_JEITA_4_3_2 (Sub-Address 0x28, Bits 14:0, Fixed: R, Programmable: R/W)

For lithium chemistries, these two registers contain the charge current settings to be used in the JEITA current vs temperature profile. ICHARGE_JEITA_6_5 contains two bit packed values, icharge_jeita_6 (bits 9:5) and icharge_jeita_5 (bits 4:0). ICHARGE_JEITA_4_3_2 contains three bit packed values, icharge_jeita_4 (bits 14:10), icharge_jeita_3 (bits 9:5), and icharge_jeita_2 (bits 4:0). These registers are ignored for lead-acid batteries or if en_jeita=0.

icharge_jeita_n (n = 2,3,4,5,6)

These five 5-bit values set the ICHARGE_TARGET values to be used in each of the JEITA current vs temperature regions. There are no defined charge currents for regions 1 and 7 because battery charging is paused in these regions. See the JEITA Temperature Qualified Charging section.

Programming of JEITA Values

REGION 1	REGION 2	REGION 3	REGION 4	REGION 5	REGION 6	REGION 7
[JEITA_T1]	[JEITA_T2]	[JEITA_T3]	[JEITA_T4]	[JEITA_T5]	[JEITA_T6]	
CHARGER OFF	icharge_jeita_2	icharge_jeita_3	icharge_jeita_4	icharge_jeita_5	icharge_jeita_6	CHARGER OFF
	vcharge_jeita_2	vcharge_jeita_3	vcharge_jeita_4	vcharge_jeita_5	vcharge_jeita_6	

CHARGER_CONFIG_BITS (Sub-Address 0x29, Bits 2:0, Fixed: R, Programmable: R/W)

This register consists of individual battery charger configuration bits which enable specific battery charger functions.

en_c_over_x_term (Sub-Address 0x29, Bit 2, Fixed: R, Programmable: R/W)

For lithium chemistries, setting this bit enables C/x charge termination, in conjunction with C_OVER_X_THRESHOLD. For lead-acid batteries, en_c_over_x_term is ignored. Default is 0.

en_lead_acid_temp_comp (Sub-Address 0x29, Bit 1, Fixed: R, Programmable: R/W)

For lead-acid batteries, setting this bit enables temperature compensated charge voltage levels as detailed in the Lead-Acid Temperature Compensated Charging section. Default is 1 for lead-acid batteries. For lithium chemistries, en_lead_acid_temp_comp is ignored.

en_jeita (Sub-Address 0x29, Bit 0, Fixed: R, Programmable: R/W)

For lithium chemistries, setting this bit enables the JEITA temperature qualified algorithm as detailed in the JEITA Temperature Qualified Charging section. The charging parameters are set by JEITA_Tn, vcharge_jeita_n, and icharge_jeita_n. Default is 1 for lithium chemistries. For lead-acid batteries, en_jeita is ignored.

DETAILED REGISTER DESCRIPTIONS

READOUTS, STATUS, AND ALERTS (Sub-Addresses 0x34 through 0x46)

MAX_CHARGE_TIMER (Sub-Address 0x30, Bits 15:0, R)

For lithium chemistries, this 16-bit word indicates the time (in seconds) that the battery has been charging. See the MAX_CHARGE_TIME register description and the section Maximum Charge Time for more information. For lead-acid batteries, MAX_CHARGE_TIMER is not used.

CV_TIMER (Sub-Address 0x31, Bits 10:0, R)

For lithium chemistries, this 16-bit word indicates the time (in seconds) that the battery has been in constant-voltage regulation. See the MAX_CV_TIME register description and the section Timer Termination for more information. For lead-acid batteries, CV_TIMER is not used.

ABSORB_TIMER (Sub-Address 0x32, Bits 10:0, R)

For LiFePO₄ and lead-acid batteries, this 16-bit word indicates the time (in seconds) that the battery has been in absorb phase. See the MAX_ABSORB_TIME register description and the sections LiFePO₄ Absorb Charge and Lead-Acid Absorb Charge for more information. For Li-Ion batteries, ABSORB_TIMER is not used.

EQUALIZE_TIMER (Sub-Address 0x33, Bits 15:0, Fixed: R, Programmable: R/W)

For lead-acid batteries, this 16-bit word indicates the time (in seconds) that the battery has been in equalization charge phase. See the EQUALIZE_TIME register description and the section Lead-Acid Equalization Charge. For lithium chemistries, EQUALIZE_TIMER is not used.

CHARGER_STATE (Sub-Address 0x34, Bits 10:0, R)

This register consists of individual battery charger state indicator bits. Individual bits are mutually exclusive (a maximum of one bit is asserted at any given time). See the section Battery Charger Algorithms for more information regarding the charger states.

equalize_charge (Sub-Address 0x34, Bit 10, R)

This bit indicates that the LTC4015 is in the equalize phase of a battery charge cycle (applies to lead-acid chemistries only).

absorb_charge (Sub-Address 0x34, Bit 9, R)

This bit indicates that the LTC4015 is in the absorb phase of a battery charge cycle (applies to LiFePO₄ and lead-acid chemistries only).

charger_suspended (Sub-Address 0x34, Bit 8, R)

This bit indicates that the LTC4015 charger is suspended, due to any of the following conditions occurring: (a) the input voltage on the V_{IN} pin falls below or within 100mV of the BATSENS pin voltage, (b) suspend_charger is written to 1 via the serial port, or (c) a system fault condition occurs (V_{IN} overvoltage, 2P5V_{CC} undervoltage, INTV_{CC} undervoltage, DRV_{CC} undervoltage, thermal shutdown, missing R_T resistor, or invalid combination of CELLS pins).

precharge (Sub-Address 0x34, Bit 7, R)

This bit indicates that the LTC4015 is in the precondition charge phase of a battery charge cycle due to the battery being below the low battery threshold of 2.9V/cell (applies to Li-Ion chemistries only).

cc_cv_charge (Sub-Address 0x34, Bit 6, R)

This bit indicates that the LTC4015 is in the CC-CV phase of a battery charge cycle.

DETAILED REGISTER DESCRIPTIONS

ntc_pause (Sub-Address 0x34, Bit 5, R)

This bit indicates that the LTC4015 is in thermistor pause state due to NTC_RATIO out of range as set by the JEITA_Tn values. See the section JEITA Temperature Qualified Charging (applies to lithium chemistries only).

timer_term (Sub-Address 0x34, Bit 4, R)

This bit indicates that the LTC4015 is in timer termination state due to battery being at the vcharge voltage for more than MAX_CV_TIME (applies to lithium chemistries only).

c_over_x_term (Sub-Address 0x34, Bit 3, R)

This bit indicates that the LTC4015 is in C/x termination state due to IBAT dropping below C_OVER_X_THRESHOLD (applies to lithium chemistries only).

max_charge_time_fault (Sub-Address 0x34, Bit 2, R)

This bit indicates that the LTC4015 is in max charge time fault state due to MAX_CHARGE_TIMER exceeding MAX_CHARGE_TIME during a charge cycle (applies to lithium chemistries only).

bat_missing_fault (Sub-Address 0x34, Bit 1, R)

This bit indicates that the LTC4015 is in battery missing fault state due to no battery detected.

bat_short_fault (Sub-Address 0x34, Bit 0, R)

This bit indicates that the LTC4015 is in battery short fault state due to a shorted battery detected.

CHARGE_STATUS (Sub-Address 0x35, Bits 3:0, R)

This register consists of individual status bits which indicate status of the battery charge current control circuitry. Individual bits are mutually exclusive (a maximum of one bit is asserted at any given time).

vin_uvcl_active (Sub-Address 0x35, Bit 3, R)

This bit indicates that the UVCLFB pin of the undervoltage current limit loop of the LTC4015 is in control of the switching charger current delivery based on VIN_UVCL_SETTING.

iin_limit_active (Sub-Address 0x35, Bit 2, R)

This bit indicates that the input current regulation loop of the LTC4015 is in control of the switching charger current delivery based on IIN_LIMIT_SETTING.

constant_current (Sub-Address 0x35, Bit 1, R)

This bit indicates that the battery charge current regulation loop of the LTC4015 is in control of the switching charger current delivery based on ICHARGE_DAC.

constant_voltage (Sub-Address 0x35, Bit 0, R)

This bit indicates that the battery voltage regulation loop of the LTC4015 is in control of the switching charger current delivery based on VCHARGE_DAC.

LIMIT_ALERTS (Sub-Address 0x36, Bits 15:0, R/Clear)

This register consists of individual alert bits which can optionally indicate that limit excursions have caused an SMBALERT to occur. The LTC4015 checks for new limits excursions at the end of every A/D measurement system cycle (approximately 6.5ms), and LIMIT_ALERTS is updated accordingly. Individual alert bits are enabled by EN_LIMIT_ALERTS.

Once asserted, alert bits remain high until disabled or cleared. Writing a 0 to any bit clears that alert. If an enabled alert is cleared and the alerting condition remains, a new alert is triggered immediately. When a new alert occurs, the LTC4015 pulls down the $\overline{\text{SMBALERT}}$ pin and holds it low until it completes a response to an alert response algorithm

DETAILED REGISTER DESCRIPTIONS

(ARA). See the section Programmable Alerts and Interrupt Controller for more information regarding the SMBALERT and ARA functions.

meas_sys_valid_alert (Sub-Address 0x36, Bit 15, R/Clear)

To achieve high measurement accuracy, the measurement system in the LTC4015 has a typical warm up time of approximately 12ms. If `en_meas_sys_valid_alert=1`, the `meas_sys_valid_alert` bit indicates that an SMBALERT has occurred because the warm-up period has passed and the A/D measurement system results are valid. This can be particularly useful in battery only mode for periodic sampling of the measurement system; see `force_meas_sys_on` for more information.

qcount_lo_alert (Sub-Address 0x36, Bit 13, R/Clear)

If `en_qcount_lo_alert=1`, this bit indicates that an SMBALERT has occurred because QCOUNT has fallen below `QCOUNT_LO_ALERT_LIMIT`.

qcount_hi_alert (Sub-Address 0x36, Bit 12, R/Clear)

If `en_qcount_hi_alert=1`, this bit indicates that an SMBALERT has occurred because QCOUNT has exceeded `QCOUNT_HI_ALERT_LIMIT`.

vbat_lo_alert (Sub-Address 0x36, Bit 11, R/Clear)

If `en_vbat_lo_alert =1`, this bit indicates that an SMBALERT has occurred because VBAT has fallen below `VBAT_LO_ALERT_LIMIT`.

vbat_hi_alert (Sub-Address 0x36, Bit 10, R/Clear)

If `en_vbat_hi_alert =1`, this bit indicates that an SMBALERT has occurred because VBAT has exceeded `VBAT_HI_ALERT_LIMIT`.

vin_lo_alert (Sub-Address 0x36, Bit 9, R/Clear)

If `en_vin_lo_alert =1`, this bit indicates that an SMBALERT has occurred because VIN has fallen below `VIN_LO_ALERT_LIMIT`.

vin_hi_alert (Sub-Address 0x36, Bit 8, R/Clear)

If `en_vin_hi_alert =1`, this bit indicates that an SMBALERT has occurred because VIN has exceeded `VIN_HI_ALERT_LIMIT`.

vsys_lo_alert (Sub-Address 0x36, Bit 7, R/Clear)

If `en_vsys_lo_alert =1`, this bit indicates that an SMBALERT has occurred because VSYS has fallen below `VSYS_LO_ALERT_LIMIT`.

vsys_hi_alert (Sub-Address 0x36, Bit 6, R/Clear)

If `en_vsys_hi_alert =1`, this bit indicates that an SMBALERT has occurred because VSYS has exceeded `VSYS_HI_ALERT_LIMIT`.

iin_hi_alert (Sub-Address 0x36, Bit 5, R/Clear)

If `en_iin_hi_alert =1`, this bit indicates that an SMBALERT has occurred because IIN has exceeded `IIN_HI_ALERT_LIMIT`.

ibat_lo_alert (Sub-Address 0x36, Bit 4, R/Clear)

If `en_ibat_lo_alert =1`, this bit indicates that an SMBALERT has occurred because IBAT has fallen below `IBAT_LO_ALERT_LIMIT`.

DETAILED REGISTER DESCRIPTIONS

die_temp_hi_alert (Sub-Address 0x36, Bit 3, R/Clear)

If `en_die_temp_hi_alert = 1`, this bit indicates that an SMBALERT has occurred because `DIE_TEMP` has exceeded `DIE_TEMP_HI_ALERT_LIMIT`.

bsr_hi_alert (Sub-Address 0x36, Bit 2, R/Clear)

If `en_bsr_hi_alert = 1`, this bit indicates that an SMBALERT has occurred because `BSR` has exceeded `BSR_HI_ALERT_LIMIT`.

ntc_ratio_hi_alert (Sub-Address 0x36, Bit 1, R/Clear)

If `en_ntc_ratio_hi_alert = 1`, this bit indicates that an SMBALERT has occurred because `NTC_RATIO` has exceeded `NTC_RATIO_HI_ALERT_LIMIT` (cold battery).

ntc_ratio_lo_alert (Sub-Address 0x36, Bit 0, R/Clear)

If `en_ntc_ratio_lo_alert = 1`, this bit indicates that an SMBALERT has occurred because `NTC_RATIO` has fallen below `NTC_RATIO_LO_ALERT_LIMIT` (hot battery).

CHARGER_STATE_ALERTS (Sub-Address 0x37, Bits 10:0, R/Clear)

This register consists of individual battery charger state alert bits. Individual alert bits will be asserted if the individual alert has been enabled and the transition into that state occurs.

Once asserted, alert bits remain high until disabled or cleared. Writing a 0 to any bit clears that alert. If an enabled alert is cleared and the alerting condition remains, a new alert is triggered immediately. When a new alert occurs, the LTC4015 pulls down the `SMBALERT` pin and holds it low until an alert response algorithm (ARA) is completed. See the section Programmable Alerts and Interrupt Controller for more information regarding the SMBALERT and ARA functions.

equalize_charge_alert (Sub-Address 0x37, Bit 10, R/Clear)

If `en_equalize_charge_alert = 1`, this bit indicates that an SMBALERT has occurred due to the occurrence of `equalize_charge` (applies to lead-acid chemistries only).

absorb_charge_alert (Sub-Address 0x37, Bit 9, R/Clear)

If `en_absorb_charge_alert = 1`, this bit indicates that an SMBALERT has occurred due to the occurrence of `absorb_charge` (applies to `LiFePO4` and lead-acid chemistries only).

charger_suspended_alert (Sub-Address 0x37, Bit 8, R/Clear)

If `en_charger_suspended_alert = 1`, this bit indicates that an SMBALERT has occurred due to the occurrence of `charger_suspended`.

precharge_alert (Sub-Address 0x37, Bit 7, R/Clear)

If `en_precharge_alert = 1`, this bit indicates that an SMBALERT has occurred due to the occurrence of `precharge`.

cc_cv_charge_alert (Sub-Address 0x37, Bit 6, R/Clear)

If `en_cc_cv_charge_alert = 1`, this bit indicates that an SMBALERT has occurred due to the occurrence of `cc_cv_charge`.

ntc_pause_alert (Sub-Address 0x37, Bit 5, R/Clear)

If `en_ntc_pause_alert = 1`, this bit indicates that an SMBALERT has occurred due to the occurrence of `ntc_pause`.

timer_term_alert (Sub-Address 0x37, Bit 4, R/Clear)

If `en_timer_term_alert = 1`, this bit indicates that an SMBALERT has occurred due to the occurrence of `timer_term`.

c_over_x_term_alert (Sub-Address 0x37, Bit 3, R/Clear)

If `en_c_over_x_term_alert = 1`, this bit indicates that an SMBALERT has occurred due to the occurrence of `c_over_x_term`.

DETAILED REGISTER DESCRIPTIONS

max_charge_time_fault_alert (Sub-Address 0x37, Bit 2, R/Clear)

If en_max_charge_time_fault_alert=1, this bit indicates that an SMBALERT has occurred due to the occurrence of a max_charge_time_fault.

bat_missing_fault_alert (Sub-Address 0x37, Bit 1, R/Clear)

If en_bat_missing_fault_alert=1, this bit indicates that an SMBALERT has occurred due to the occurrence of bat_missing_fault.

bat_short_fault_alert (Sub-Address 0x37, Bit 0, R/Clear)

If en_bat_short_fault_alert=1, this bit indicates that an SMBALERT has occurred due to the occurrence of bat_short_fault.

CHARGE_STATUS_ALERTS (Sub-Address 0x38, Bits 3:0, R/Clear)

This register consists of individual battery charger charge status alert bits. Individual alert bits will be asserted if the individual alert has been enabled and the transition into that state occurs.

Once asserted, alert bits remain high until disabled or cleared. Writing a 0 to any bit clears that alert. If an enabled alert is cleared and the alerting condition remains, a new alert is triggered immediately. When a new alert occurs, the LTC4015 pulls down the SMBALERT pin and holds it low until an alert response algorithm (ARA) is completed. See the section Programmable Alerts and Interrupt Controller for more information regarding the SMBALERT and ARA functions.

vin_uvcl_active_alert (Sub-Address 0x38, Bit 3, R/Clear)

If en_vin_uvcl_active_alert=1, this bit indicates that an SMBALERT has occurred because the UVCL undervoltage current limit regulation loop of the LTC4015 has taken control of the switching regulator charger delivery (vin_uvcl_active=1).

iin_limit_active_alert (Sub-Address 0x38, Bit 2, R/Clear)

If en_iin_limit_active_alert=1, this bit indicates that an SMBALERT has occurred because the input current regulation loop of the LTC4015 has taken control of the switching regulator charger delivery (iin_limit_active=1).

constant_current_alert (Sub-Address 0x38, Bit 1, R/Clear)

If en_constant_current_alert=1, this bit indicates that an SMBALERT has occurred because the battery charge current regulation loop of the LTC4015 has taken control of the switching charger current delivery (constant_current=1).

constant_voltage_alert (Sub-Address 0x38, Bit 0, R/Clear)

If en_constant_voltage_alert=1, this bit indicates that an SMBALERT has occurred because the battery voltage regulation loop of the LTC4015 has taken control of the switching charger current delivery (constant_voltage=1).

SYSTEM_STATUS (Sub-Address 0x39, Bits 13:0, R)

This register consists of individual real-time status bits which indicate various system conditions.

charger_enabled (Sub-Address 0x39, Bit 13, R)

This bit indicates that the LTC4015 is actively charging a battery.

mppt_en_pin (Sub-Address 0x39, Bit 11, R)

This bit indicates that the external MPPT pin is detected as being high and maximum power point tracking is enabled.

equalize_req (Sub-Address 0x39, Bit 10, R)

This bit indicates that a rising edge has been detected at the EQ pin and a lead-acid equalization charge is running or is queued to run. See Lead-Acid Equalization Charge.

DETAILED REGISTER DESCRIPTIONS

drvcc_good (Sub-Address 0x39, Bit 9, R)

This bit indicates that the DRV_{CC} pin voltage is above the DRV_{CC} undervoltage lockout level (4.3V typical).

cell_count_error (Sub-Address 0x39, Bit 8, R)

This bit indicates that an invalid combination of CELLS pin settings have been detected.

ok_to_charge (Sub-Address 0x39, Bit 6, R)

This bit indicates that all system conditions are met to allow battery charging operation.

no_rt (Sub-Address 0x39, Bit 5, R)

This bit indicates that no frequency setting resistor is detected on the RT pin. The RT pin impedance detection circuit will typically indicate a missing R_T resistor for values above 1.4MΩ.

thermal_shutdown (Sub-address 0x39, Bit 4, R)

This bit indicates that the LTC4015 is in thermal shutdown protection due to an excessively high die temperature (typically 160°C and above).

vin_ovlo (Sub-address 0x39, Bit 3, R)

This bit indicates that the LTC4015 is in input voltage shutdown protection due to an input voltage above its protection shutdown threshold of approximately 38.6V (typical).

vin_gt_vbat (Sub-Address 0x39, Bit 2, R)

This bit indicates that the V_{IN} pin input voltage is sufficiently above the BATSENS battery voltage to allow charging operation (typically +200mV).

intvcc_gt_4p3v (Sub-Address 0x39, Bit 1, R)

This bit indicates that the INTV_{CC} voltage is above the switching charger undervoltage lockout threshold value of 4.3V (typical).

intvcc_gt2p8v (Sub-Address 0x39, Bit 0, R)

This bit indicates that the INTV_{CC} pin voltage is above the measurement system undervoltage lockout threshold value of 2.8V (typical).

VBAT (Sub-Address 0x3A, Bits 15:0, R)

This 16-bit two's complement word indicates the A/D measurement result for the BATSENS pin.

$V_{\text{BATSENS/cellcount}} = [\text{VBAT}] \cdot 192.264\mu\text{V}$ for lithium chemistries.

$V_{\text{BATSENS/cellcount}} = [\text{VBAT}] \cdot 128.176\mu\text{V}$ for lead-acid.

VIN (Sub-Address 0x3B, Bits 15:0, R)

This 16-bit two's complement word indicates the A/D measurement result for the V_{IN} pin voltage divided by 30. Input voltage, $V_{\text{VIN}} = [\text{VIN}] \cdot 1.648\text{mV}$

VSYS (Sub-Address 0x3C, Bits 15:0, R)

This 16-bit two's complement word indicates the A/D measurement result for the SYS pin voltage divided by 30. System voltage, $V_{\text{SYS}} = [\text{VSYS}] \cdot 1.648\text{mV}$

IBAT (Sub-Address 0x3D, Bits 15:0, R)

This 16-bit word indicates the A/D measurement of $37.5 \cdot (V_{\text{CSP}} - V_{\text{CSN}})$ at the CSP, CSN pins. Negative values are represented in two's complement notation and indicate current flowing out of (discharging) the battery. Battery current = $[\text{IBAT}] \cdot 1.46487\mu\text{V}/R_{\text{SNSB}}$

DETAILED REGISTER DESCRIPTIONS

IIN (Sub-Address 0x3E, Bits 15:0, R)

This 16-bit word indicates the A/D measurement of $37.5 \cdot (V_{CLP} - V_{CLN})$ at the CLP, CLN pins. Input current = $[IIN] \cdot 1.46487\mu V/R_{SNSI}$

DIE_TEMP (Sub-Address 0x3F, Bits 15:0, R)

This 16-bit two's complement word indicates the A/D measurement result for LTC4015 die temperature. LTC4015 temperature = $(DIE_TEMP - 12010)/45.6^{\circ}C$

NTC_RATIO (Sub-Address 0x40, Bits 15:0, R)

This 16-bit two's complement word indicates the A/D measurement result for $R_{NTC}/(R_{NTC} + R_{NTCBIAS})$. The thermistor value can be determined by the expression $R_{NTC} = R_{NTCBIAS} \cdot NTC_RATIO/(21,845.0 - NTC_RATIO)$. Recall that the thermistor has a negative temperature coefficient so higher temperatures correspond to lower NTC_RATIO readings and vice-versa.

BSR (Sub-Address 0x41, Bits 15:0, R)

This 16-bit word indicates the calculated per cell battery series resistance. The battery series resistance is proportional to the battery charge current setting resistor, R_{SNSB} , and can be computed in Ω from $[BSR/500] \cdot R_{SNSB}$ for lithium chemistries, or $[BSR/750] \cdot R_{SNSB}$ for lead-acid chemistries. Multiply this value by the total number of cells to calculate total battery series resistance. ICHARGE_BSR is the value of IBAT used in the BSR calculation.

JEITA_REGION (Sub-Address 0x42, Bits 2:0, R)

For lithium chemistries, this register indicates the JEITA battery temperature region as determined by the A/D measurement result NTC_RATIO and the values of the JEITA_Tn registers. Recall that the thermistor has a negative temperature coefficient so higher temperatures make lower NTC_RATIO readings and vice-versa. See the section JEITA Temperature Qualified Charging for a diagram of the temperature regions.

CHEM_AND_CELLS (Sub-Address 0x43, Bits 11:0, R)

This register indicates the state of the CHEMn and CELLSn pins. See the sections Chemistry Selection and Cells Selection for more information on defining the pin states.

chem (Sub-Address 0x43, Bits 11:8, R)

These four bits indicate the chemistry algorithm set by the CHEMn pins, as shown in the following table. For additional safety, these bits can be checked during test and/or by the application software to ensure that LTC4015 is connected properly on the circuit board.

chem:	CHEM1,CHEM0:	Chemistry Algorithm:
0x0	L, L	Li-Ion Programmable
0x1	H, H	Li-Ion Fixed 4.2V/cell
0x2	L, Z	Li-Ion Fixed 4.1V/cell
0x3	Z, L	Li-Ion Fixed 4.0V/cell
0x4	L, H	LiFePO ₄ Programmable
0x5	H, Z	LiFePO ₄ Fixed Fast Charge
0x6	Z, H	LiFePO ₄ Fixed 3.6V/cell
0x7	Z, Z	Lead-Acid Fixed
0x8	H, L	Lead-Acid Programmable

cells (Sub-Address 0x43, Bits 3:0, R)

These four bits indicate the battery cell count set by the CELLSn pins. For additional safety, these bits can be checked during test and/or by the application software to ensure that LTC4015 is connected properly on the circuit board.

DETAILED REGISTER DESCRIPTIONS

NUMBER OF CELLS	CELLS2	CELLS1	CELLS0
Invalid	L	L	L
1	L	L	H
2	L	H	L
3	L	H	H
4	L	L	Z
5	L	Z	L
6	L	H	Z
7	L	Z	H
8	L	Z	Z
9	H	L	L
Invalid	H	L	H
Invalid	H	H	L
12*	H	H	H

*Lead-acid only

ICHARGE_DAC (Sub-Address 0x44, Bits 4:0, R)

This register represents the actual charge current setting applied to the charge current reference DAC. ICHARGE_DAC is ramped up/down to implement digital soft-start/stop. The LTC4015 sets the value of ICHARGE_DAC based on battery chemistry, charger state (CHARGER_STATE), thermistor reading (NTC_RATIO), and charger settings including ICHARGE_TARGET, ijeita_n, and TJEITA_n. Recall that the charge current is regulated by controlling the voltage across an external current sense resistor R_{SNSB} . The servo voltage is given by $(ICHARGE_DAC + 1) \cdot 1\text{mV}$. The charge current servo level is thus given by $(ICHARGE_DAC + 1) \cdot 1\text{mV}/R_{SNSB}$.

VCHARGE_DAC (Sub-Address 0x45, Bits 5:0, R)

This register represents the actual target battery voltage setting applied to the charge voltage reference DAC. The LTC4015 sets the value of VCHARGE_DAC based on battery chemistry, charger state (CHARGER_STATE), thermistor reading (NTC_RATIO), and charger settings including VCHARGE_SETTING, vjeita_n, TJEITA_n, VABSORB_DELTA, VEQUALIZE_DELTA, en_jeita, and en_lead_acid_temp_comp. See also JEITA Temperature Qualified Charging and Lead-Acid Temperature Compensated Charging.

IIN_LIMIT_DAC (Sub-Address 0x46, Bits 5:0, R)

This register represents the actual input current limit setting applied to the input current limit reference DAC. This register follows IIN_LIMIT_SETTING.

VBAT_FILT (Sub-Address 0x47, Bits 15:0, R)

Digitally filtered two's complement ADC measurement result for battery voltage.

ICHARGE_BSR (Sub-Address 0x48, Bits 15:0, R)

This 16-bit two's complement word is the value of IBAT (0x3D) used in calculating BSR.

TELEMETRY_VALID (Sub-Address 0x4A, Bit 0, R)

This bit being set to 1 indicates the output of the LTC4015's telemetry system is valid.

TYPICAL APPLICATIONS

Application Circuit 1: Li-Ion Battery Charger, 2 = Cell, 8A (Typical Performance Characteristics)

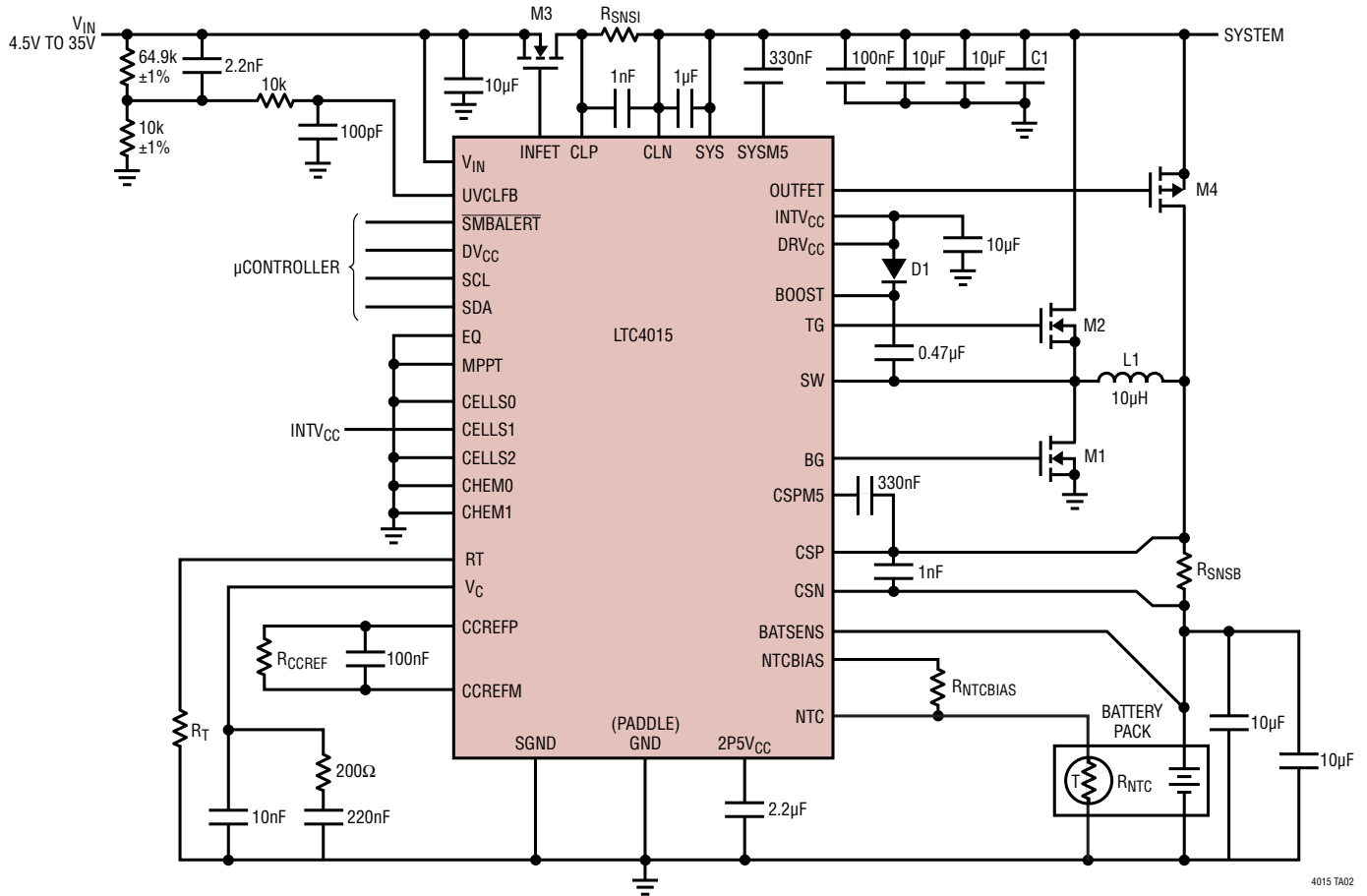

- R_T: 95.3k ±1%
- R_{CCREF}: 301kΩ, 0.1%, 25ppm/C°, SUSUMU, RG1608P-3013-B-TS
- R_{SNSI}: 3mΩ, SUSUMU, KRL3216T4-M-R003-F
- R_{SNSB}: 4mΩ, SUSUMU, KRL3216T4-M-R004-F
- R_{NTCBIAS}: 10k ±1%
- R_{NTC}: VISHAY NTC50402E3103FLT
- L1: 10μH, COIL CRAFT XAL8080_103ME OR WÜRTH ELEKTRONIK 7443321000
- M1, M2: FAIRCHILD FDMC8030 (DUAL)
- M3: FAIRCHILD FDMC8327L
- M4: VISHAY Si7611DN
- D1: DIODES INC 1N4448HLP
- C1: 120μF 40V, 40HVH120M

4015 TA02

TYPICAL APPLICATIONS

Solar Lead-Acid Battery Charger, 6-Cell 10.7A

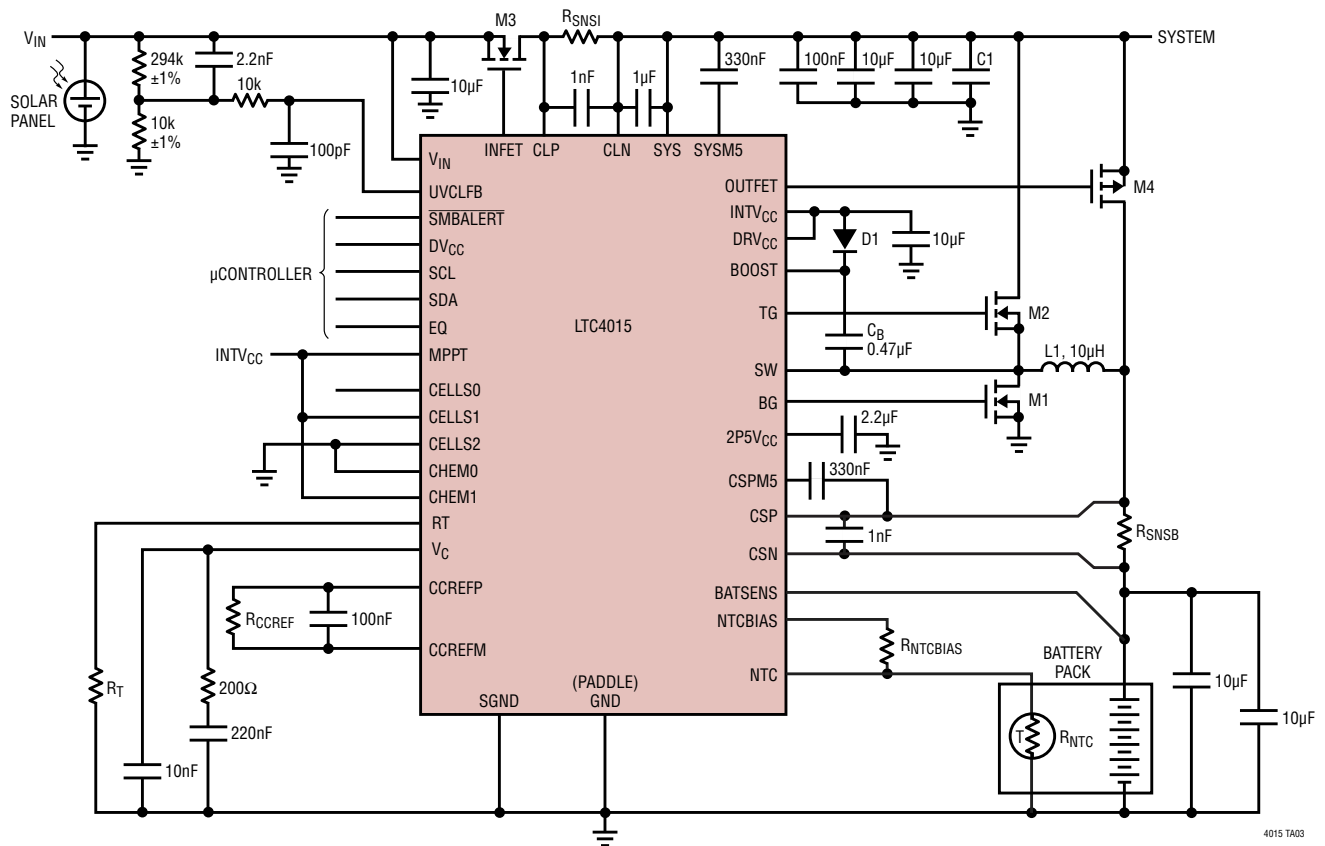

R_T : 95.3k \pm 1%
 R_{CCREF} : 301k Ω , \pm 0.1%, 25ppm/C°, SUSUMU RG1608P-3013-B-T5
 R_{SNSI} : 3m Ω , VISHAY WSK06123L000FEA (10.7A INPUT CURRENT LIMIT)
 R_{SNSB} : 3m Ω , VISHAY WSK06123L000FEA
 $R_{NTCBIAS}$: 10k \pm 1%
 R_{NTC} : VISHAY NTC0402E3103FLT

L_1 : 10 μ H, COIL CRAFT XAL1010_103ME OR WÜRTH ELEKTRONIK 7443321000
 M_1 , M_2 : FAIRCHILD FDMC8030 (DUAL)
 M_3 : FAIRCHILD FDMC8327L
 M_4 : VISHAY Si7611DN
 D_1 : DIODES INC 1N4448HLP
 C_1 : 120 μ F 40V, 40HVH120M

4015 TA03

REVISION HISTORY

REV	DATE	DESCRIPTION	PAGE NUMBER
A	02/16	Add a bullet in the Data Sheet Conventions section.	3
		Add Range to V_{IN} and V_{BAT} in the Parameter section.	4
		Add text to Note 11.	9
		Add text to NTC (Pin 11).	13
		Add text to Cells Selection section.	24
		Add text to end of 2nd paragraph on the left.	27
		Edit last paragraph on the left.	34
		Add text to the 1st paragraph in the LTC4015 Charge Algorithm Overview section. Add (per cell) to the bottom table.	35
		Edit IRMS equation.	44
		Add text to 4th and 5th paragraph on the right.	46
		Add text to the mppt_en_i2c section.	61
		Add text to 1st paragraph of VCHARGE_SETTING section.	62
		Edit schematic in Typical Applications section. Add LTC3300-1, LTC3305 and delete LT3651 and LTC4012 in Related Parts section.	76
B	04/17	Update Typical Application schematic.	1
		Change $V_{SYS} = 35V$.	7
		Modify Note 4.	9
		Modify UVCLFB (Pin 8) section.	13
		Correct Chemo to (Pin 36).	14
		Update Block Diagram.	15
		Update I ² C Timing Diagram	16
		Update Table 7.	26
		Modify Maximum Charge Time section.	30
		Update Li-Ion LiFePo4 section.	32
		Update Table under Operation section.	34
		Update Figure 8 and Lead-Acid Charging Parameters table.	35
		Update Figure 9.	38
		Modify equation $KQC = 8333.33Hz/V$.	39
		Modify Coulomb Counter Applications section.	39
Modify UVCLFB Resistor Divider Selection section.	45, 46		
Update Typical Applications schematics.	72, 73		

TYPICAL APPLICATION

Solar Lead-Acid Battery Charger, 6-Cell 10.7A, System Fed from Battery

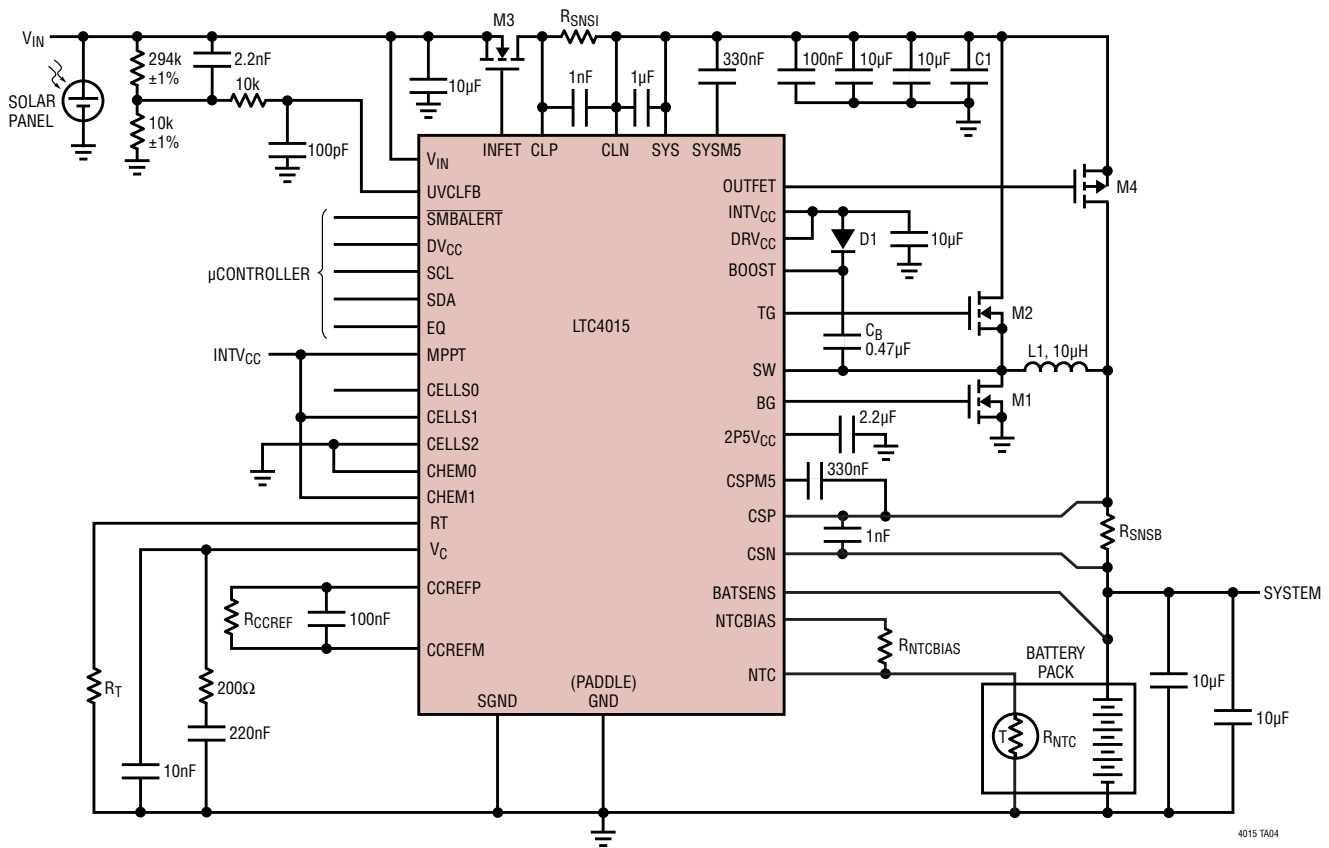

R_T : 95.3k \pm 1%
 R_{CCREF} : 301k Ω , \pm 0.1%, 25ppm/C $^\circ$, SUSUMU RG1608P-3013-B-T5
 R_{SNSI} : 3m Ω , VISHAY WSK06123L000FEA (10.7A INPUT CURRENT LIMIT)
 R_{SNSB} : 3m Ω , VISHAY WSK06123L000FEA
 $R_{NTCBIAS}$: 10k \pm 1%
 R_{NTC} : VISHAY NTC0402E3103FLT

L_1 : 10 μ H, COIL CRAFT XAL1010_103ME OR WÜRTH ELEKTRONIK 7443321000
 M_1 , M_2 : FAIRCHILD FDMC8030 (DUAL)
 M_3 : FAIRCHILD FDMC8327L
 M_4 : VISHAY Si7611DN
 D_1 : DIODES INC 1N4448HLP
 C_1 : 120 μ F 40V, 40HVH120M



RELATED PARTS

PART NUMBER	DESCRIPTION	COMMENTS
LT3652/LT3652HV	Power Tracking 2A Buck Battery Charger	Input Supply Voltage Regulation Loop for Peak Power Tracking in (MPPT) Solar Applications, Standalone, $4.95V \leq V_{IN} \leq 32V$ (40V Abs Max), 1MHz Timer or C/10 Termination, 3mm \times 3mm DFN-12 Package and MSOP-12 Packages, LT3652HV Version Up to $V_{IN} = 34V$
LTC4020	55V Buck-Boost Multi-Chemistry Battery Charger	Constant-Current/Constant-Voltage Buck-Boost Switching Controller Regulator Charger, 5mm \times 7mm QFN-38 Package
LTC4121/LTC4121-4.2	Multi-Chemistry Buck Battery Charger	Constant-Current/Constant-Voltage 400mA Monolithic Buck Switching Regulator Charger, $4.4V \leq V_{IN} \leq 40V$, 3mm \times 3mm QFN-16 Package
LTC4155	Dual Input Power Manager/3.5A Li-Ion Battery Charger	High Efficiency, Monolithic Switching Regulator, 4mm \times 5mm QFN-28 Package
LTC3300-1	High Efficiency Bidirectional Multicell Battery Balancer	Bidirectional Synchronous Flyback Balancing of Up to Six Li-Ion or LiFePO ₄ Cells in Series. Up to 10A Balancing Current (Set by External Components). Bidirectional Architecture Minimizes Balancing Time and Power Dissipation. Up to 92% Charge Transfer Efficiency. 7mm \times 7mm QFN-48 and 7mm \times 7mm LQFP-48 Packages
LTC3305	Lead-Acid Battery Balancer	Single IC Balances Up to Four 12V Lead-Acid Batteries in Series. Stand Alone Operation Requires No External μ P or Control Circuitry. Thermally Enhanced TSSOP-36 Package

4015fbs

Looking for pricing, stock, or lifecycle information?

Click below to explore more details on WIN SOURCE:

-  [View DC2039A on WIN SOURCE](#)
-  [Analog Devices Inc. Information](#)

Optimize Your Supply Chain with WIN SOURCE Solutions

-  Global Sourcing Solution
-  Obsolete Management
-  Cost Control Management
-  Shortage Management
-  Alternative Solution
-  Excess Inventory Management