



**THE DATASHEET OF
HCMS-05-S-03.00-02-ST4**



DO NOT SCALE FROM THIS PRINT

DIMENSIONS ARE IN INCHES UNLESS OTHERWISE NOTED		TOLERANCES ARE:	
ONE PLACE DECIMALS ±.1	THREE PLACE DECIMALS ± .005	ANGLES ± 1°	
TWO PLACE DECIMALS ±.01	FOUR PLACE DECIMALS ± .0020		

TITLE: .100 C.L MOLD TO POS. SINGLE ROW, MALE ASSEMBLY
 DWG NO: HCMS-XX-X-XX-XX-XXX-XXX
 SHEET 1 OF 1

-D (DOUBLE END)

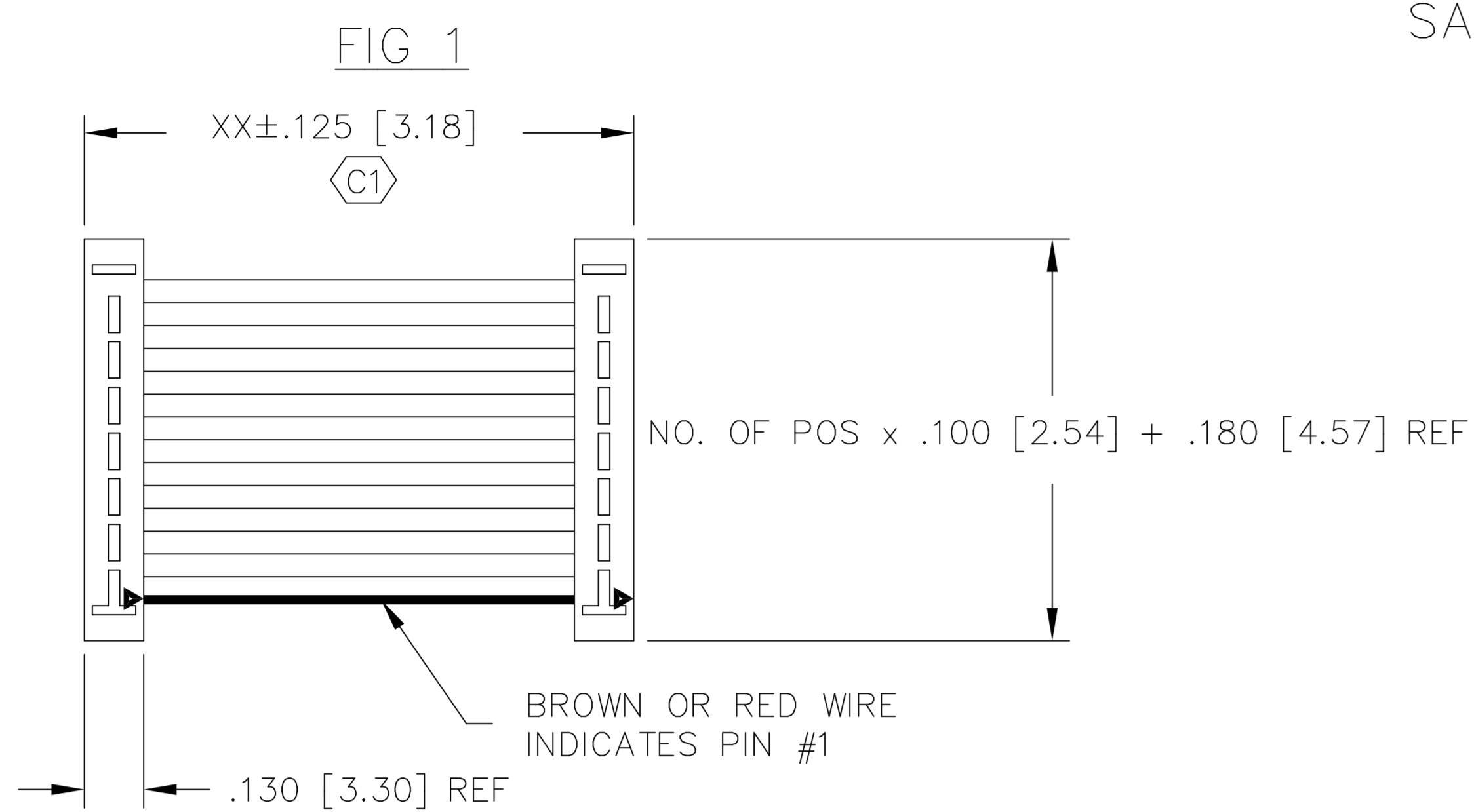

-S (SINGLE END)

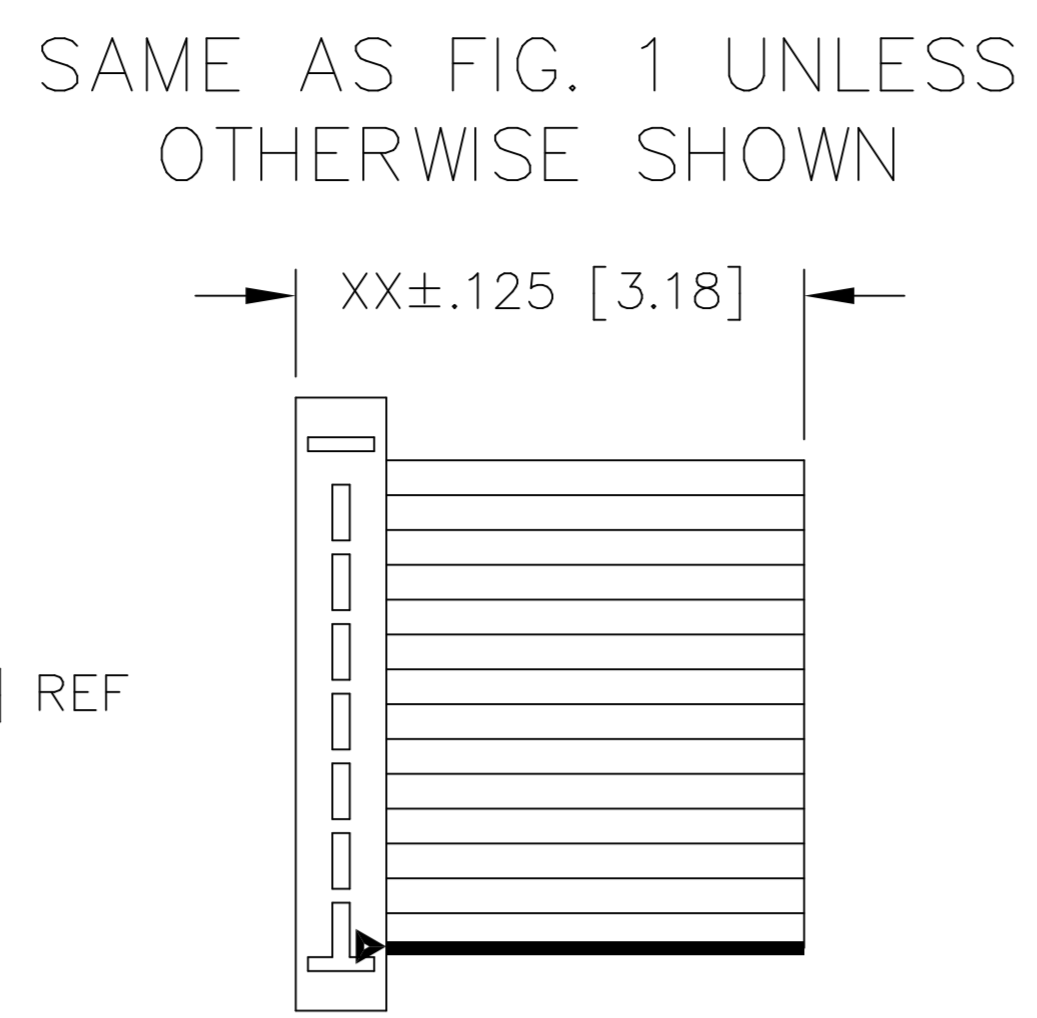

-T (TRANSFER END)

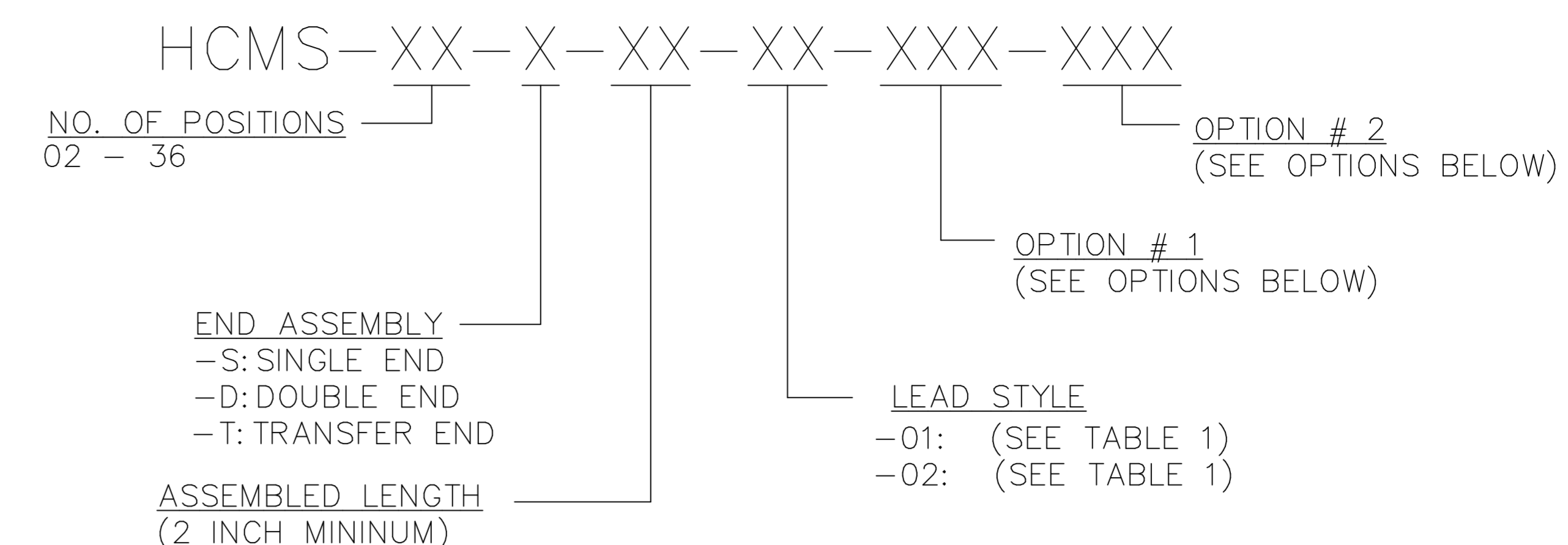
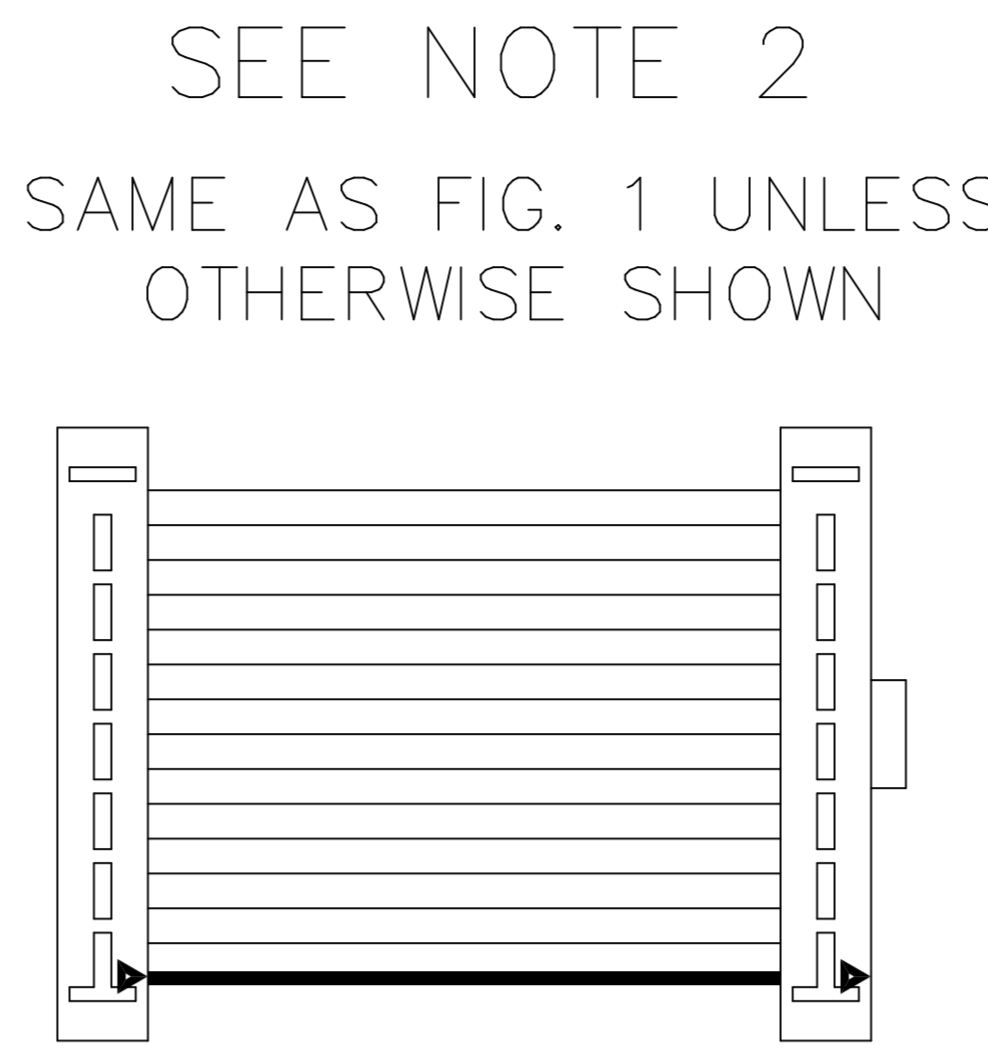

LEAD STYLE	"A"	1	2	3 (-T END ONLY)
-01	.120 [3.05]	HCMS-XX-01-X	CB-XX-28-7/36-100-C	HCSS-XX-01-X
-02	.230 [5.84]	HCMS-XX-02-X	CB-XX-28-7/36-100-C	HCSS-XX-01-X

SPECIFY NO. OF POS. IN PART CALLOUT -XX

NOTE: SUB-ASSEMBLY 1 OR 3 TO BE PRESSED TOGETHER WITH NO GAPS BETWEEN CABLE & BODIES.

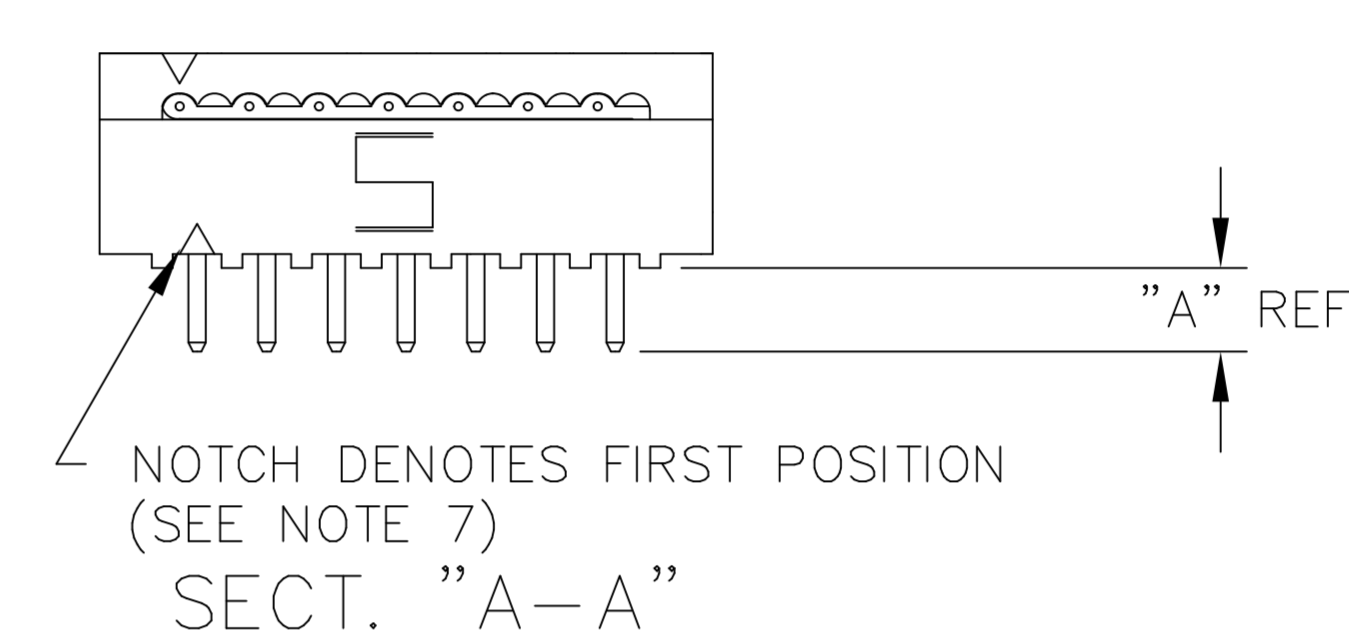
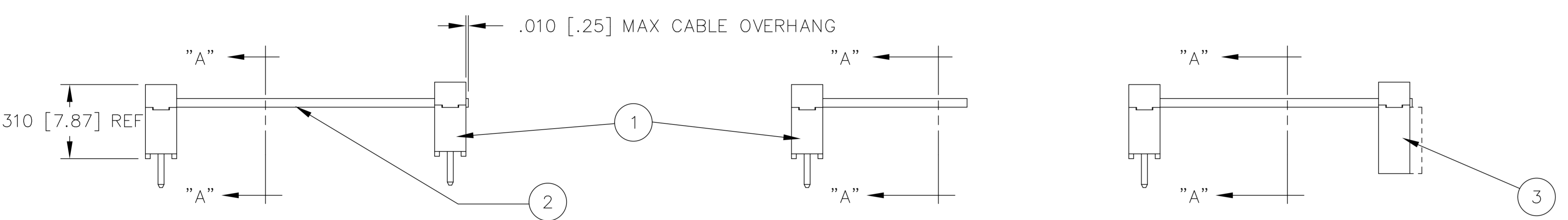

- NOTES:
- IF OPTION IS SPECIFIED WITH -T END ASSEMBLY, SUB-ASSEMBLIES B & C WILL BE HCSS-XX-01-X.
 - HIDDEN LINES ARE USED TO SHOW POLARIZATION WHEN USING -T OPTION.
 - Ⓢ REPRESENTS CRITICAL DIMENSION FOR STATISTICAL PROCESS CONTROL.
 - ALL ASSEMBLIES TO BE 100% ELECTRICALLY TESTED FOR SHORTS AND OPENS.
 - ALL ASSEMBLIES TO BE 100% HI-POT TESTED AT 1000V.
 - WIRE: 28 AWG, 7/36, TINNED, STRANDED WITH PVC INSULATOR
 - FOR -R OR -RW OPTION, CABLE RIB ORIENTATION CAN BE EITHER TOWARDS OR AWAY FROM THE CAP.
 - WHEN CUTTING CABLE TO LENGTH, CONDUCTORS SHOULD NOT EXTEND PAST THE CABLE INSULATION, EXTENDING LESS THAN 25% OF CABLE THICKNESS ON CONSECUTIVE AND LESS THAN 50% OF CABLE THICKNESS ON NON-CONSECUTIVE STRANDS IS CONSIDERED A PROCESS INDICATOR.

PLATING

-T = .000150 BRIGHT ACID TIN ON ENTIRE CONTACT. (USED ONLY WITH FEMALE STRIP OF A -T END OPTION - USE HCSS-XX-01-TX.)

-S = .000010 Au. ON TAIL AREA WITH THE BALANCE OF .000150 BRIGHT ACID TIN - USE HCMS-XX-XX-S. (DO NOT USE WITH HCSS-XX-01-T-X.)

(STANDARD PLATING IS .000150 BRIGHT ACID TIN OVER ENTIRE TERMINAL - USE HCMS-XX-XX-T. FOR A -T OPTION, STANDARD PLATING FOR THE FEMALE END IS .000150 BRIGHT ACID TIN, EXCEPT CONTACT AREA IS .000010 Au. - USE HCSS-XX-01-SX.)

-G GRAY CABLE

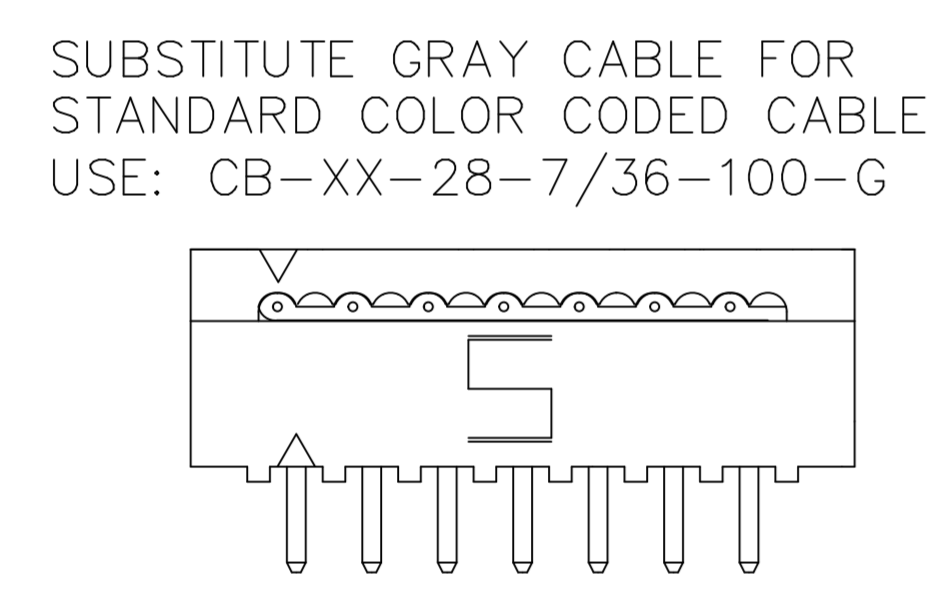

-ST'X' STRIPPED & TINNED

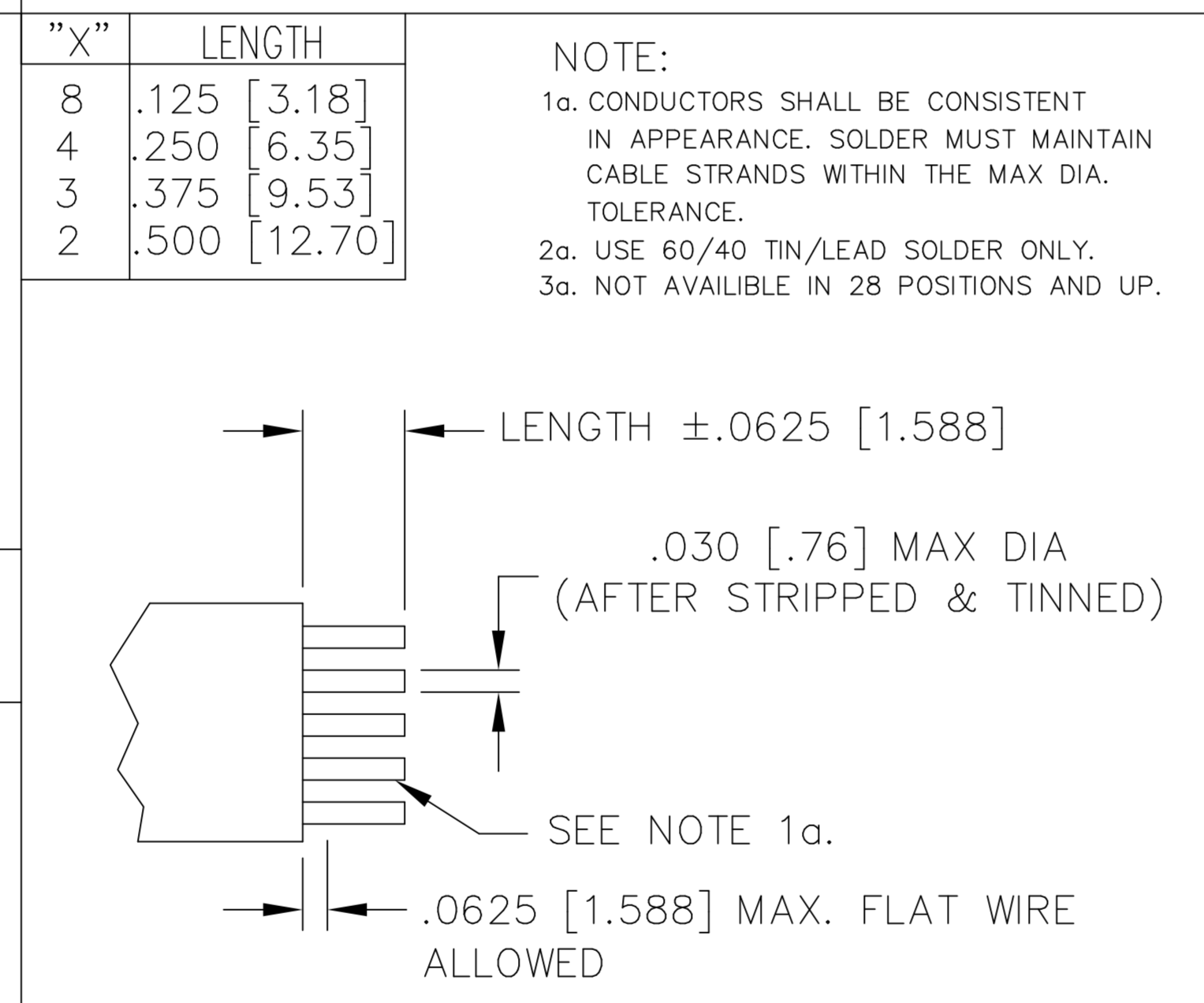

-SXX DAISY CHAIN- SINGLE

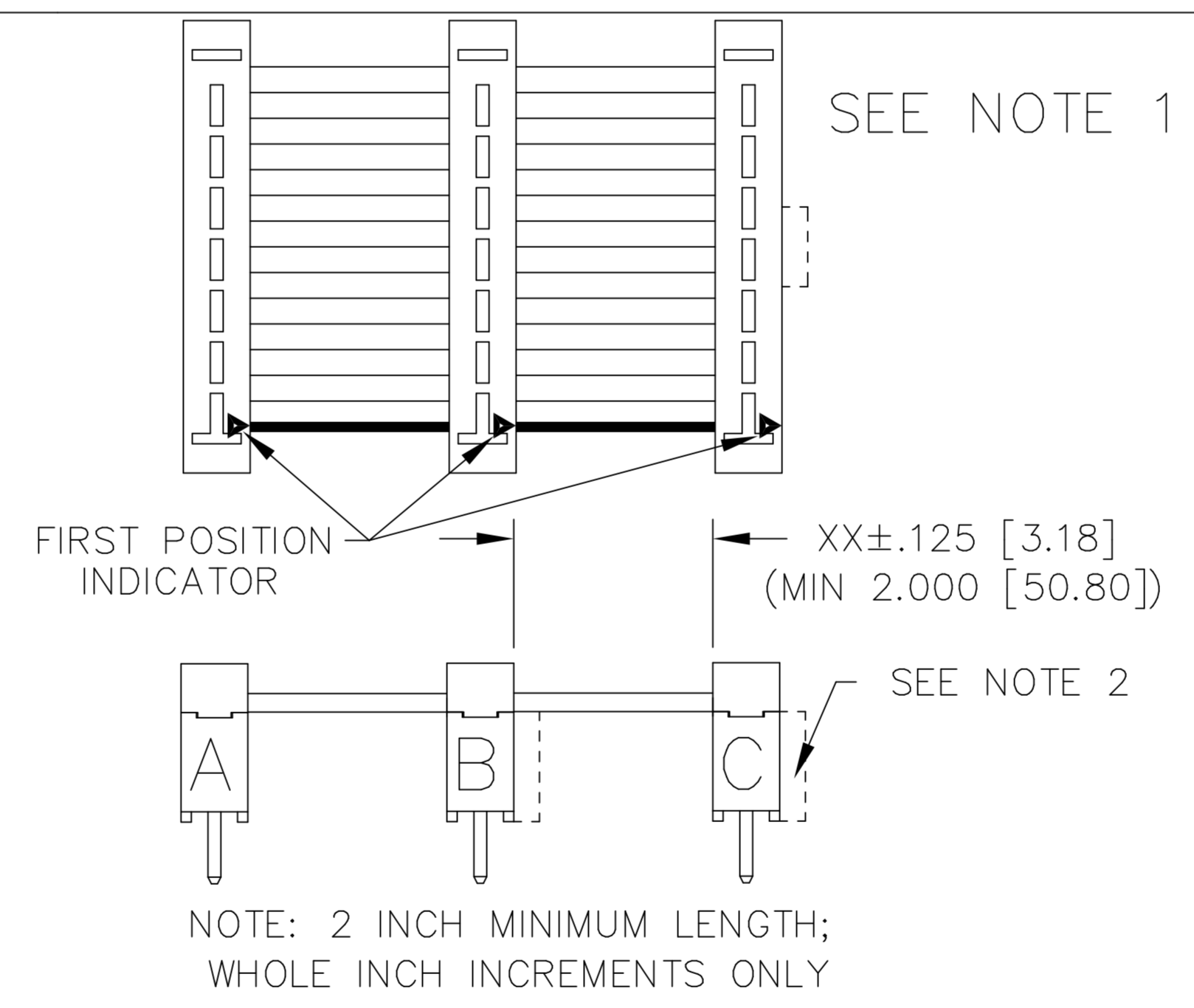

-RW REVERSE WIRING

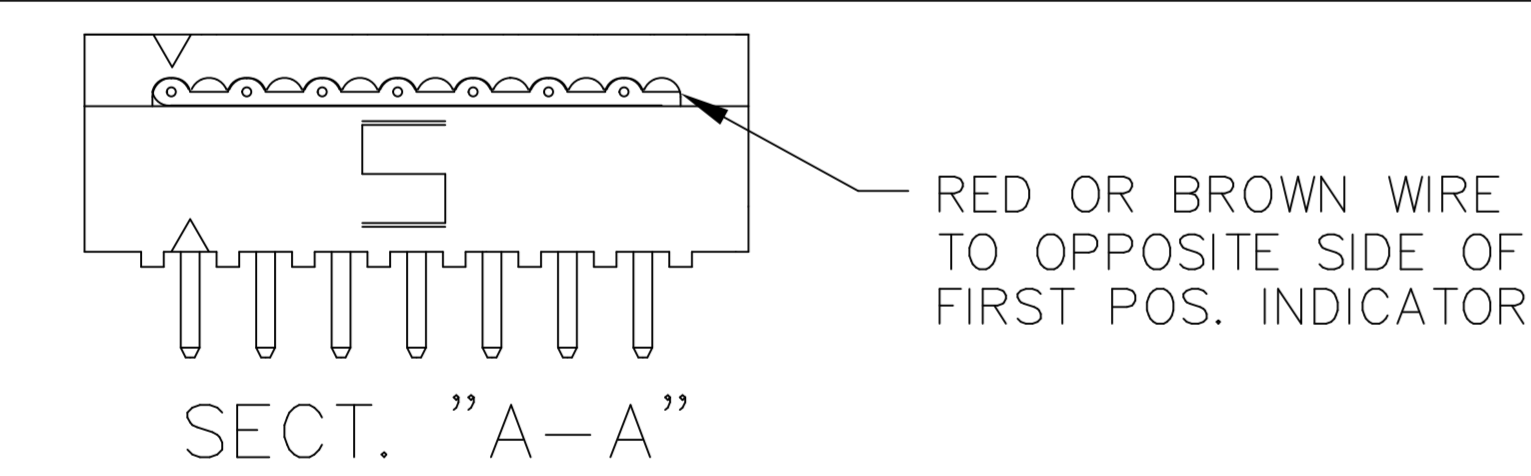

-R REVERSED CONNECTOR

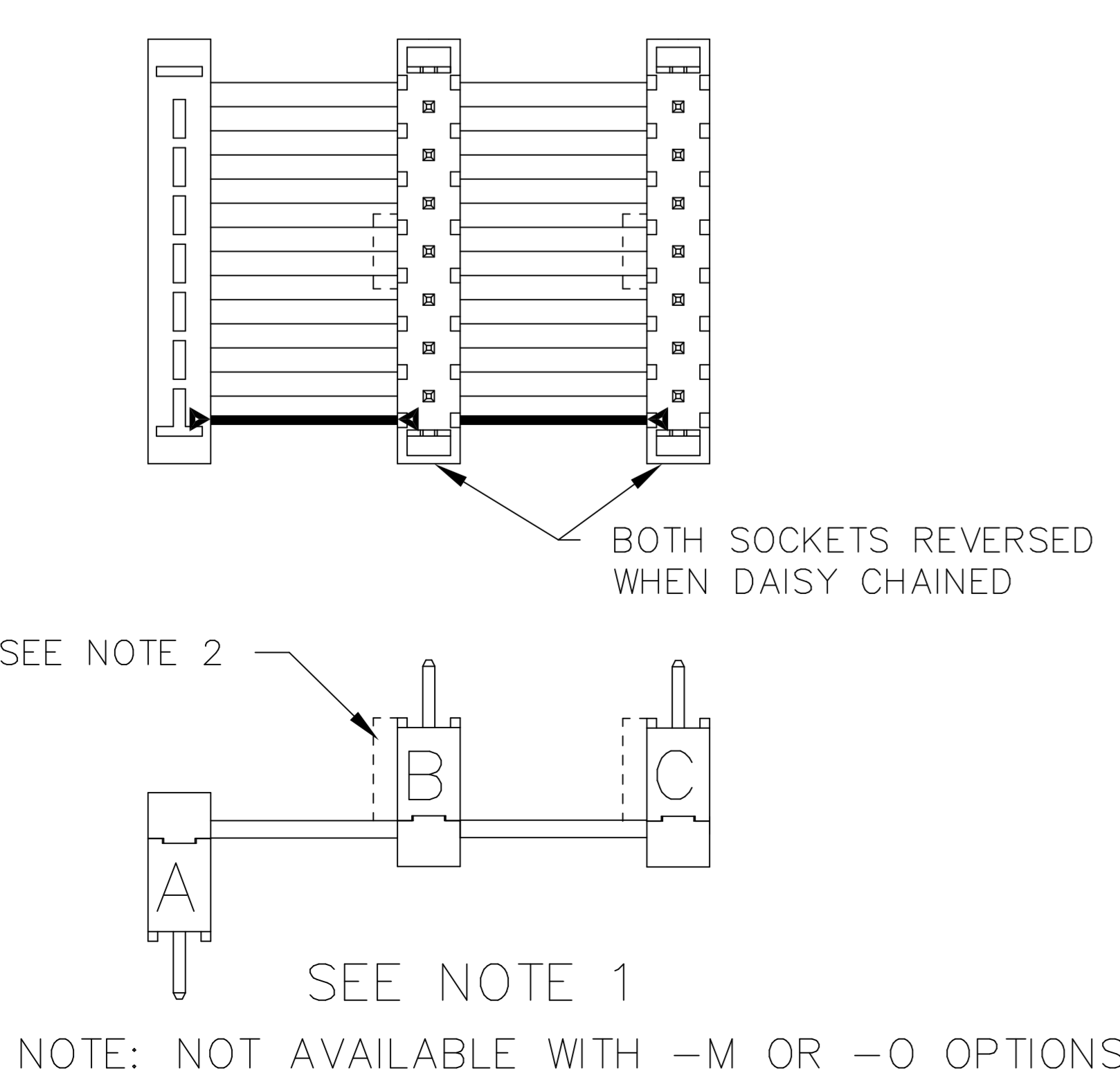

-M MIDDLE REVERSED

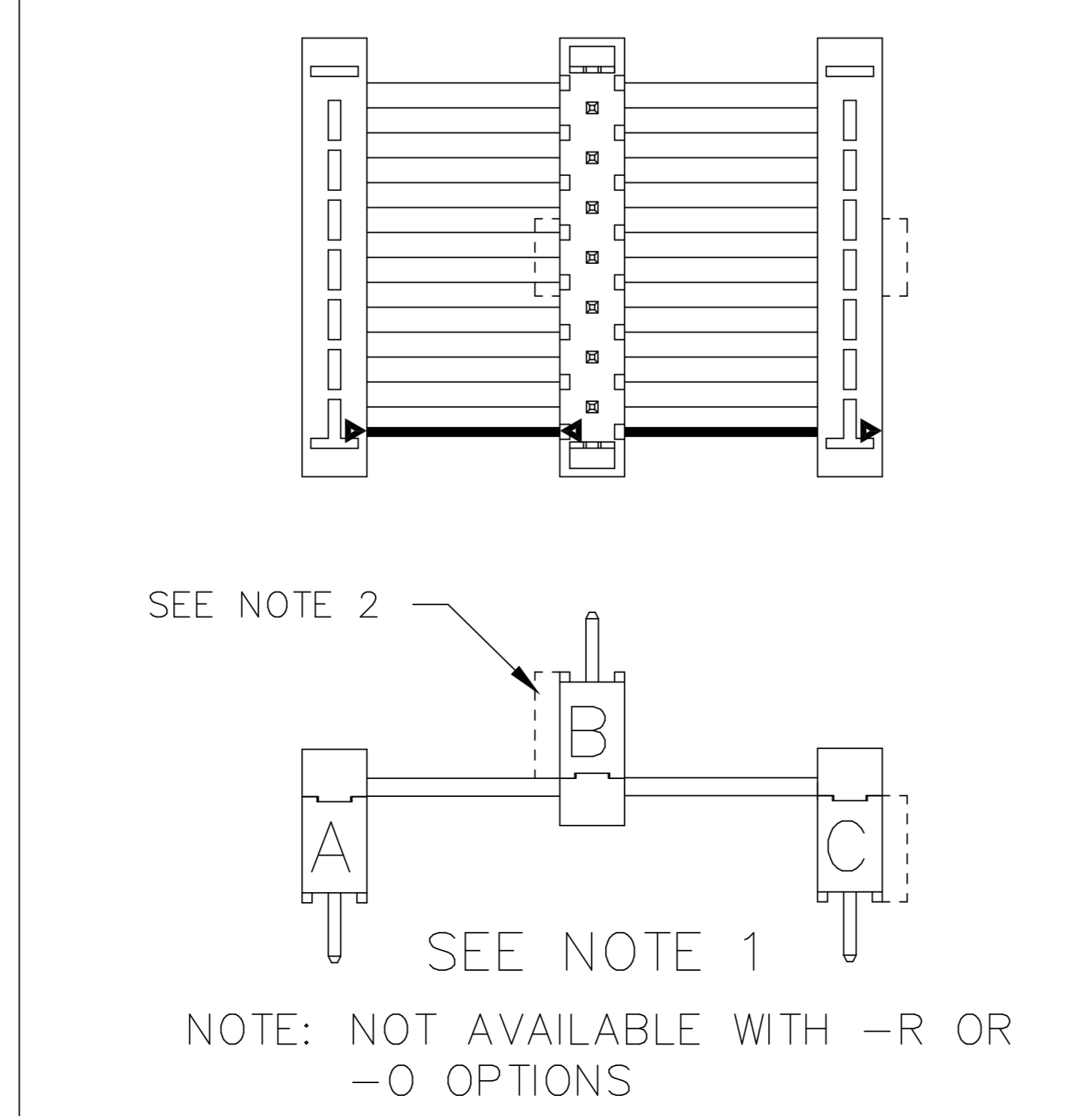

-O OUTSIDE REVERSED

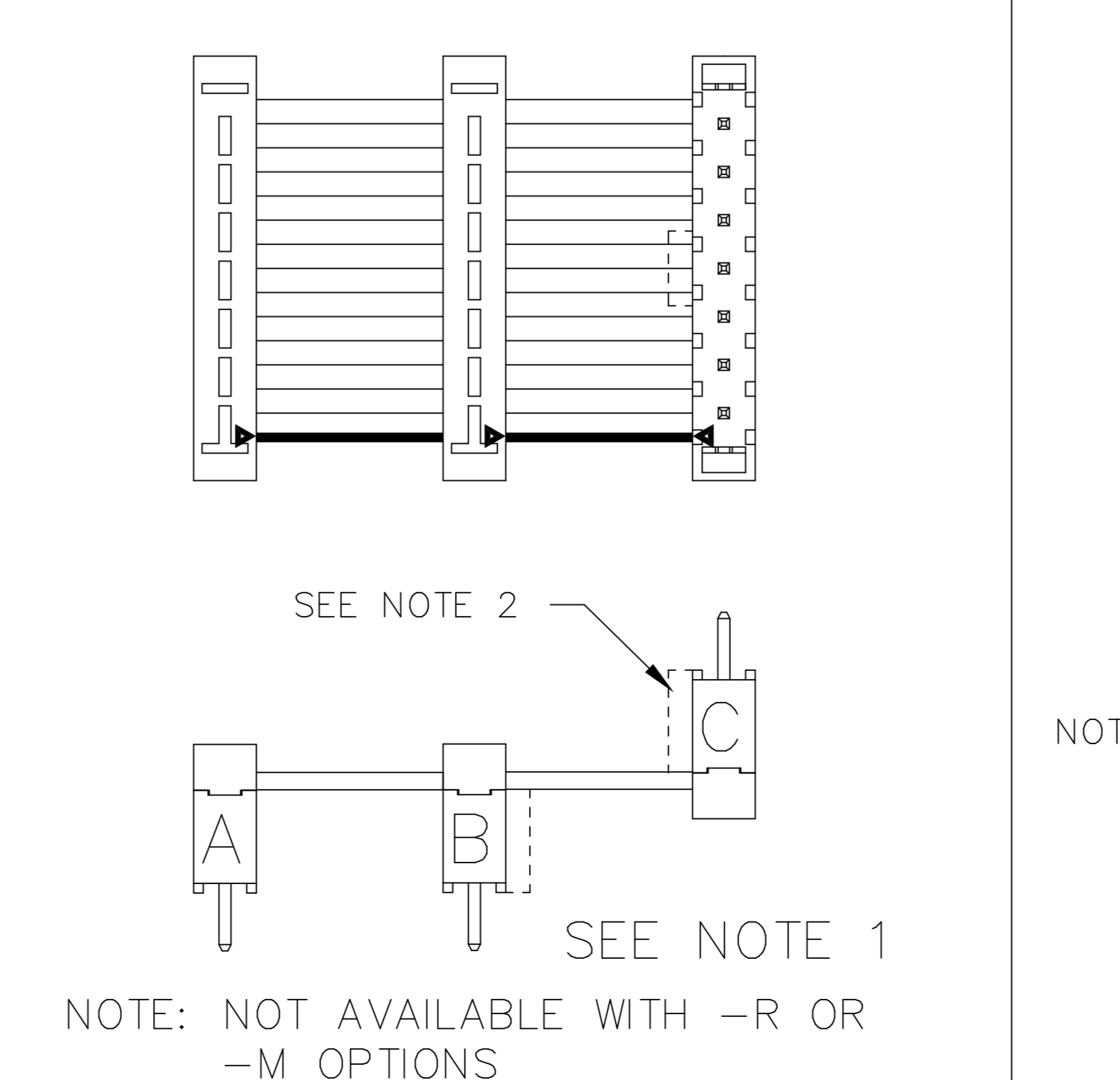

-PXX

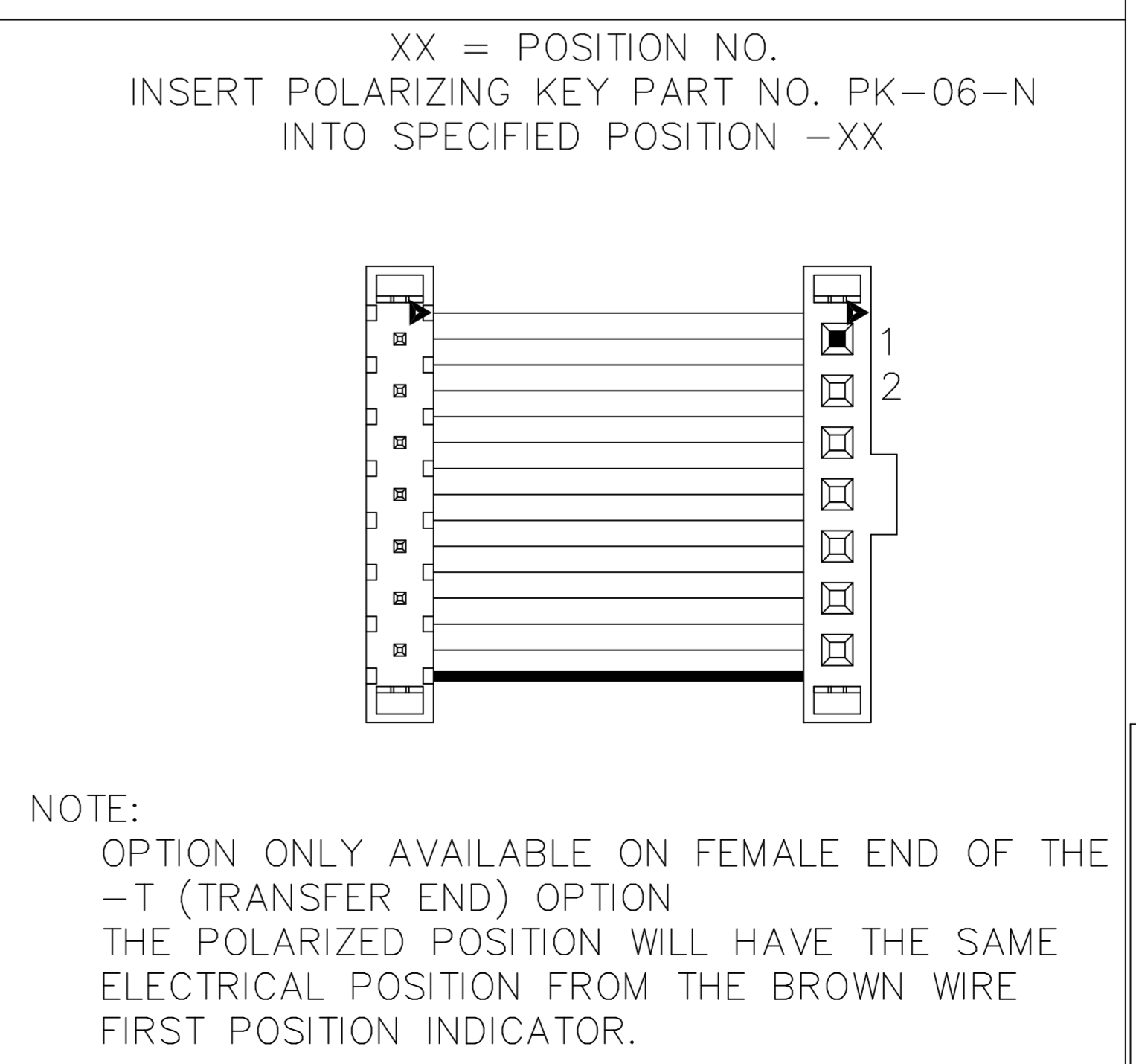

-N NOTCH POLARIZATION

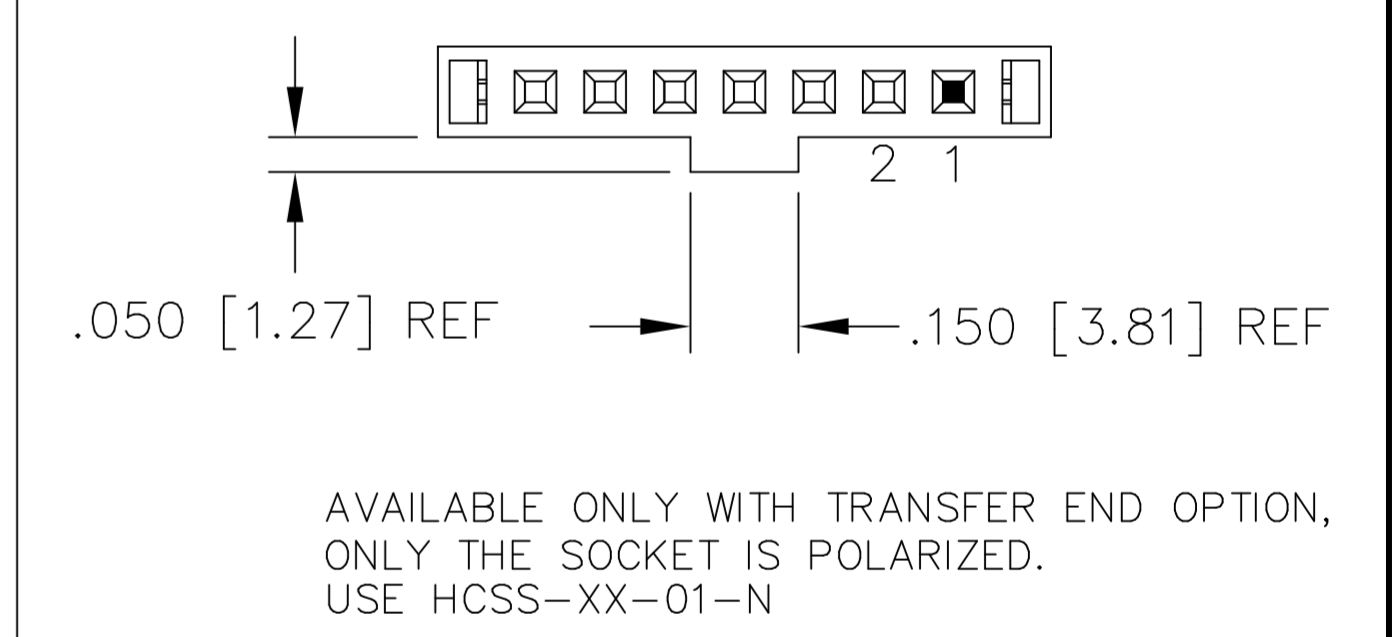

-BXX BREAKOUT OPTION

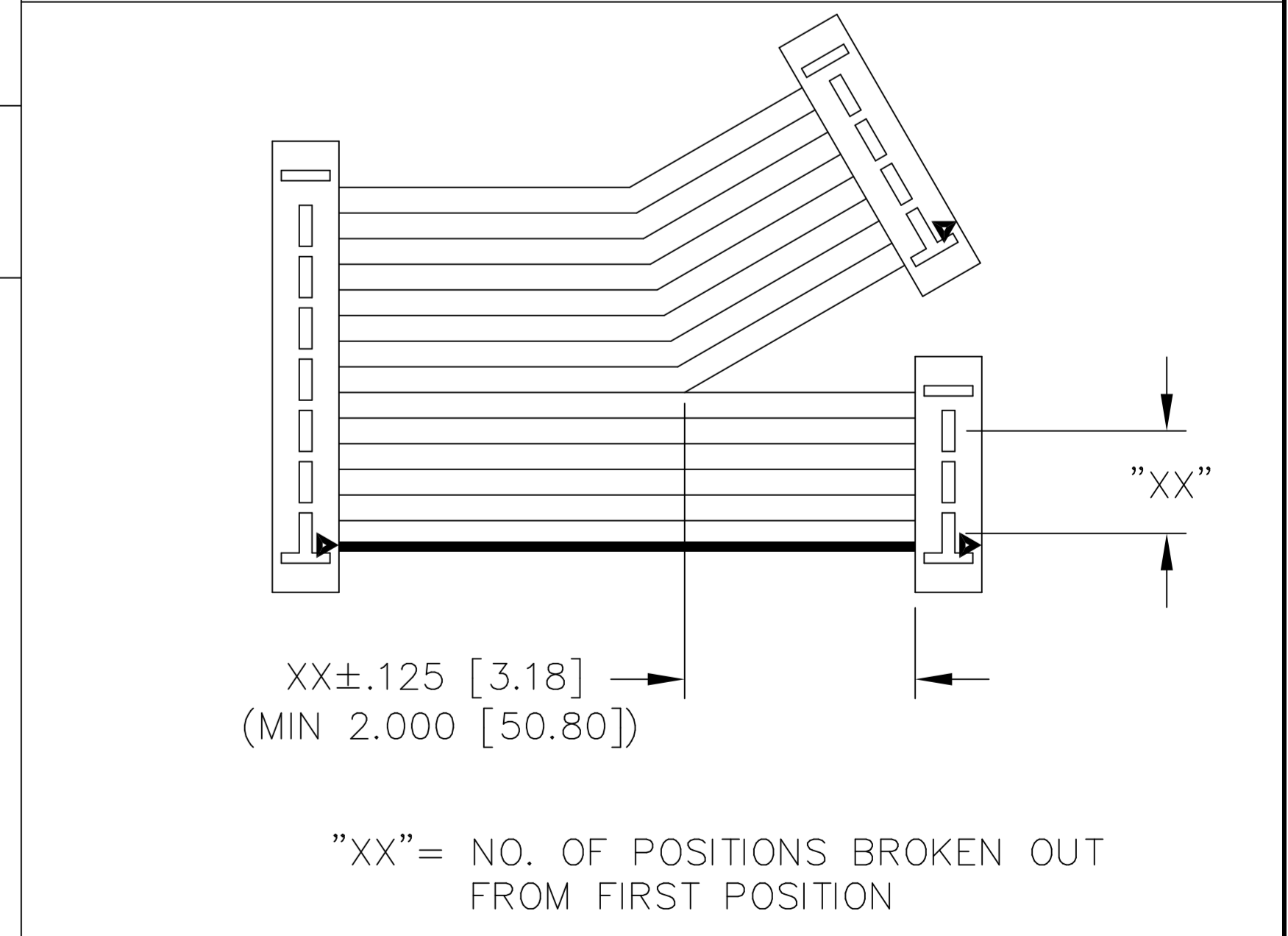



PROPRIETARY NOTE
 THIS DOCUMENT CONTAINS INFORMATION CONFIDENTIAL AND PROPRIETARY TO SAMTEC INC. AND SHALL NOT BE REPRODUCED OR TRANSFERRED TO OTHER DOCUMENTS OR DISCLOSED TO OTHERS OR USED FOR ANY PURPOSE OTHER THAN THAT FOR WHICH IT WAS OBTAINED WITHOUT THE EXPRESSED WRITTEN CONSENT OF SAMTEC INC.

samtec EP\CABLE HCMS-ASM
 520 PARK EAST BLVD. NEW ALBANY, INDIANA 47150
 PHONE (812) 944-6733 P.O. BOX 1147
 CODE 53522
 MADE BY: KOLB 8-3-90
 HCMS-XX-X-XX-XX-XXX-XXX
 SHEET 1 OF 1

Looking for pricing, stock, or lifecycle information?

Click below to explore more details on WIN SOURCE:

-  [View HCMS-05-S-03.00-02-ST4 on WIN SOURCE](#)
-  [Samtec Inc. Information](#)

Optimize Your Supply Chain with WIN SOURCE Solutions

-  Global Sourcing Solution
-  Obsolete Management
-  Cost Control Management
-  Shortage Management
-  Alternative Solution
-  Excess Inventory Management