



THE DATASHEET OF RT9715GGS



90mΩ, 2A/1.5A/1.1A/0.7A High-Side Power Switches with Flag

General Description

The RT9715 is a cost-effective, low-voltage, single N-MOSFET high-side Power Switch IC for USB application. Low switch-on resistance (typ. 90mΩ) and low supply current (typ. 50uA) are realized in this IC.

The RT9715 integrates an over-current protection circuit, a short fold back circuit, a thermal shutdown circuit and an under-voltage lockout circuit for overall protection. Besides, a flag output is available to indicate fault conditions to the local USB controller. Furthermore, the chip also integrates an embedded delay function to prevent miss-operation from happening due to inrush-current. The RT9715 is an ideal solution for USB power supply and can support flexible applications since it is available in various packages such as SOT-23-5, SOP-8, MSOP-8 and WDFN-8L 3x3.

Ordering Information

- RT9715 □ □ □
- Package Type
 - B : SOT-23-5
 - BG : SOT-23-5 (G-Type)
 - BR : SOT-23-5 (R-Type)
 - S : SOP-8
 - F : MSOP-8
 - QW : WDFN-8L 3x3 (W-Type)
 - Lead Plating System
 - G : Green (Halogen Free and Pb Free)
 - Output Current/EN Function
 - A : 2A/Active High
 - B : 2A/Active Low
 - C : 1.5A/Active High
 - D : 1.5A/Active Low
 - E : 1.1A/Active High
 - F : 1.1A/Active Low
 - G : 0.7A/Active High
 - H : 0.7A/Active Low

Note :

Richtek products are :

- ▶ RoHS compliant and compatible with the current requirements of IPC/JEDEC J-STD-020.
- ▶ Suitable for use in SnPb or Pb-free soldering processes.

Features

- 90mΩ (typ.) N-MOSFET Switch
- Operating Range : 2.7V to 5.5V
- Reverse Blocking Current
- Under Voltage Lockout
- Deglitched Fault Report ($\overline{\text{FLG}}$)
- Thermal Protection with Foldback
- Over Current Protection
- Short Circuit Protection
- UL Approved—E219878 
- Nemko Approved—NO49621
- RoHS Compliant and Halogen Free

Applications

- USB Peripherals
- Notebook PCs

Pin Configurations

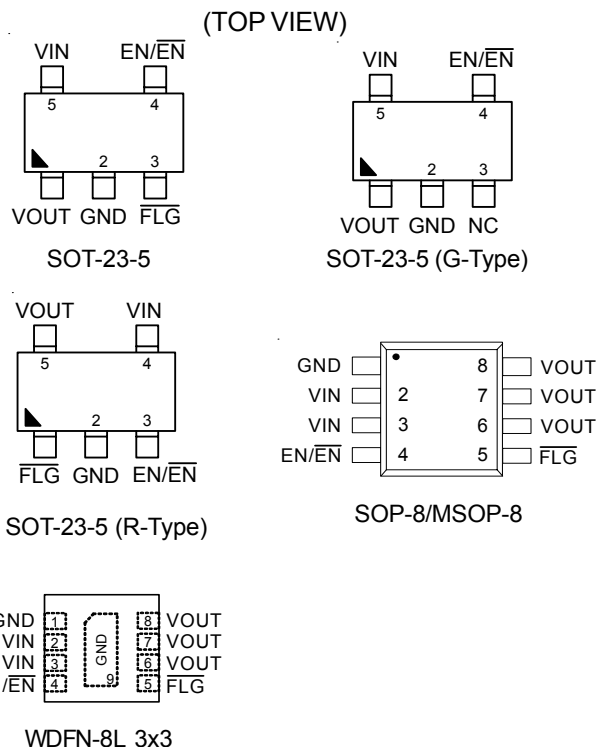

Marking Information

For marking information, contact our sales representative directly or through a Richtek distributor located in your area.

Typical Application Circuit

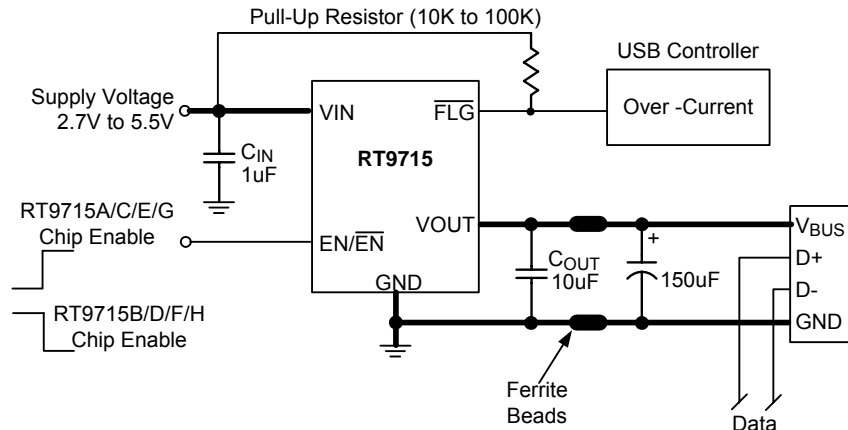

Note : A low-ESR 150µF aluminum electrolytic or tantalum between V_{OUT} and GND is strongly recommended to meet the 330mV maximum droop requirement in the hub V_{BUS}. (see Application Information Section for further details)

Functional Pin Description

Pin No.					Pin Name	Pin Function
SOT-23-5	SOT-23-5 (G-Type)	SOT-23-5 (R-Type)	SOP-8 / MSOP-8	WDFN-8L 3X3		
1	1	5	6, 7, 8	6, 7, 8	V _{OUT}	Output Voltage.
2	2	2	1	1	GND	Ground.
3	--	1	5	5	FLG	Fault FLAG Output.
4	4	3	4	4	EN/EN	Chip Enable (Active High/Low).
5	5	4	2, 3	2, 3	V _{IN}	Power Input Voltage.
--	3	--	--	--	NC	No Internal Connection.
--	--	--	--	9 (Exposed Pad)		The exposed pad must be soldered to a large PCB and connected to GND for maximum power dissipation.

Function Block Diagram

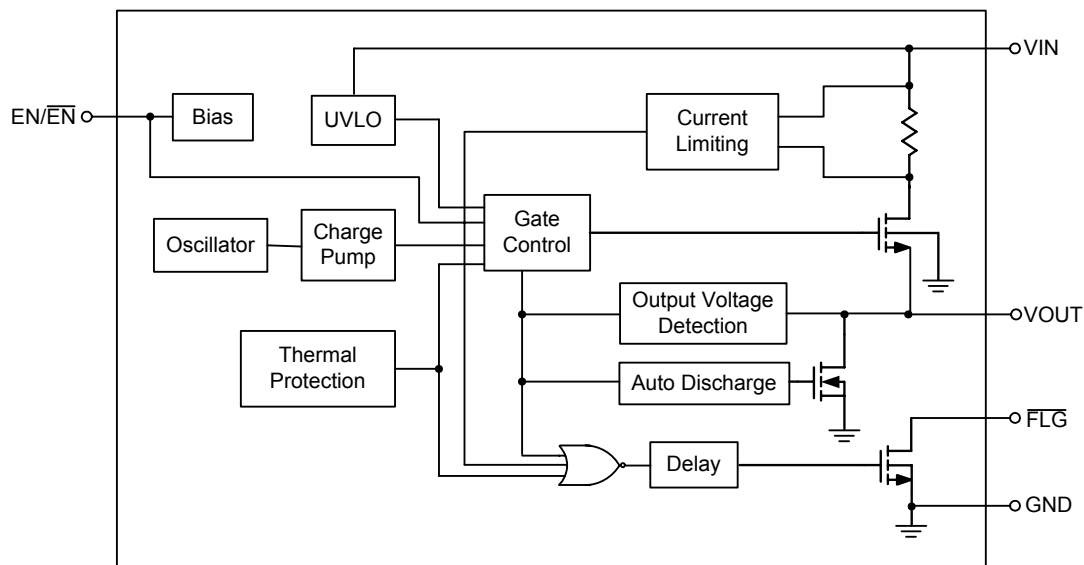

Absolute Maximum Ratings (Note 1)

- Supply Input Voltage, V_{IN} ----- 6V
- EN Voltage ----- -0.3V to 6V
- FLAG Voltage ----- 6V
- Power Dissipation, P_D @ $T_A = 25^\circ\text{C}$
 - SOT-23-5 ----- 300mW
 - SOP-8 ----- 469mW
 - MSOP-8 ----- 469mW
 - WDFN-8L 3x3 ----- 694mW
- Package Thermal Resistance (Note 2)
 - SOT-23-5, θ_{JA} ----- 250°C/W
 - SOP-8, θ_{JA} ----- 160°C/W
 - MSOP-8, θ_{JA} ----- 160°C/W
 - WDFN-8L 3x3, θ_{JA} ----- 108°C/W
- Junction Temperature ----- 150°C
- Lead Temperature (Soldering, 10 sec.) ----- 260°C
- Storage Temperature Range ----- -65°C to 150°C
- ESD Susceptibility (Note 3)
 - HBM (Human Body Mode) ----- 2kV
 - MM (Machine Mode) ----- 200V

Recommended Operating Conditions (Note 4)

- Supply Input Voltage, V_{IN} ----- 2.7V to 5.5V
- EN Voltage ----- 0V to 5.5V
- Junction Temperature Range ----- -40°C to 100°C
- Ambient Temperature Range ----- -40°C to 85°C

Electrical Characteristics

($V_{IN} = 5\text{V}$, $C_{IN} = 1\mu\text{F}$, $C_{OUT} = 10\mu\text{F}$, $T_A = 25^\circ\text{C}$, unless otherwise specified)

Parameter		Symbol	Test Conditions	Min	Typ	Max	Unit
Input Quiescent Current		I_Q	Switch On, $V_{OUT} = \text{Open}$	--	50	70	uA
Input Shutdown Current		I_{SHDN}	Switch Off, $V_{OUT} = \text{Open}$	--	0.1	1	
Switch On Resistance	RT9715A/B	$R_{DS(ON)}$	$V_{IN} = 5\text{V}$, $I_{OUT} = 1.5\text{A}$	--	90	110	mΩ
	RT9715C/D		$V_{IN} = 5\text{V}$, $I_{OUT} = 1.3\text{A}$	--	90	110	
	RT9715E/F		$V_{IN} = 5\text{V}$, $I_{OUT} = 1\text{A}$	--	90	110	
	RT9715G/H		$V_{IN} = 5\text{V}$, $I_{OUT} = 0.6\text{A}$	--	90	110	
Current Limit	RT9715A/B	I_{LIM}	$V_{OUT} = 4\text{V}$	2	2.5	3.2	A
	RT9715C/D			1.5	2	2.8	
	RT9715E/F			1.1	1.5	2.1	
	RT9715G/H			0.7	1	1.4	
Short Current	RT9715A/B	I_{SC_FB}	$V_{OUT} = 0\text{V}$, Measured Prior to Thermal Shutdown	--	1.7	--	A
	RT9715C/D			--	1.4	--	
	RT9715E/F			--	1	--	
	RT9715G/H			--	0.7	--	

To be continued

Parameter		Symbol	Test Conditions	Min	Typ	Max	Unit
EN/EN Threshold	Logic_High Voltage	V _{IH}	V _{IN} = 2.7V to 5.5V	2	--	--	V
	Logic_Low Voltage	V _{IL}	V _{IN} = 2.7V to 5.5V	--	--	0.8	V
EN/EN Input Current		I _{EN/EN}	V _{EN} = 5V	--	0.01	0.1	uA
Output Leakage Current		I _{LEAKAGE}	V _{EN} = 0V, R _{LOAD} = 0Ω	--	0.5	1	uA
Output Turn-On Rise Time		T _{ON_RISE}	10% to 90% of V _{OUT} Rising	--	200	--	us
FLG Output Resistance		R _{FLG}	I _{SINK} = 1mA	--	20	--	Ω
FLG Off Current		I _{FLG_OFF}	V _{FLG} = 5V	--	0.01	1	uA
FLG Delay Time		T _D	From fault condition to FLG assertion	5	12	20	ms
Shutdown Auto-Discharge Resistance		R _{Discharge}	V _{EN} = 0V, V _{EN} = 5V	--	100	150	Ω
Under-Voltage Lockout		V _{UVLO}	V _{IN} Rising	1.3	1.7	--	V
Under-Voltage Hysteresis		ΔV _{UVLO}	V _{IN} Decreasing	--	0.1	--	V
Thermal Shutdown Protection		T _{SD}	V _{OUT} > 1V	--	120	--	°C
			V _{OUT} = 0V	--	100	--	°C
Thermal Shutdown Hysteresis			V _{OUT} = 0V	--	20	--	°C

- Note 1.** Stresses beyond those listed under “Absolute Maximum Ratings” may cause permanent damage to the device. These are stress ratings only, and functional operation of the device at these or any other conditions beyond those indicated in the operational sections of the specifications is not implied. Exposure to absolute maximum rating conditions for extended periods may affect device reliability.
- Note 2.** θ_{JA} is measured in the natural convection at T_A = 25°C on a low effective single layer thermal conductivity test board of JEDEC 51-3 thermal measurement standard.
- Note 3.** Devices are ESD sensitive. Handling precaution is recommended.
- Note 4.** The device is not guaranteed to function outside its operating conditions.

Typical Operating Characteristics

On Resistance vs. Input Voltage

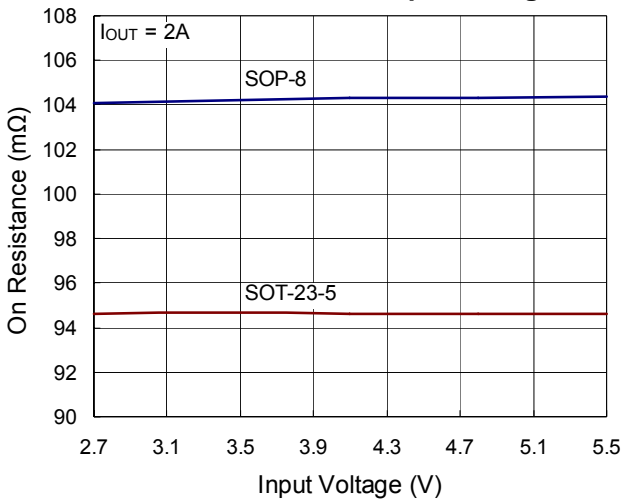

On Resistance vs. Temperature

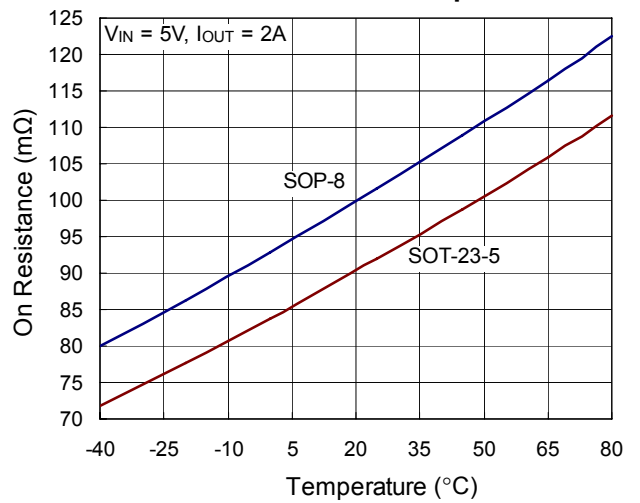

Quiescent Current vs. Input Voltage

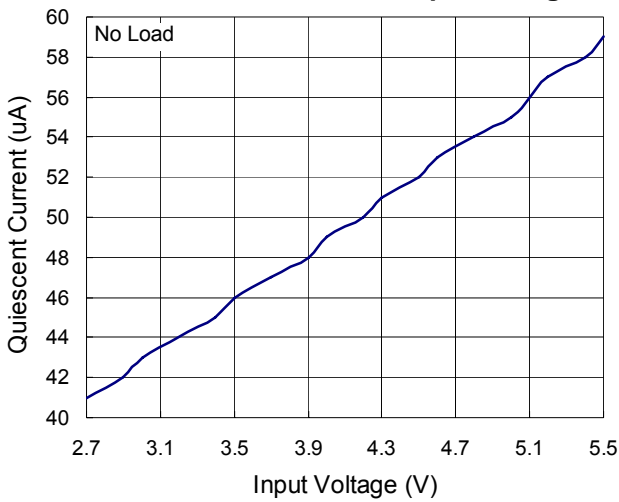

Quiescent Current vs. Temperature

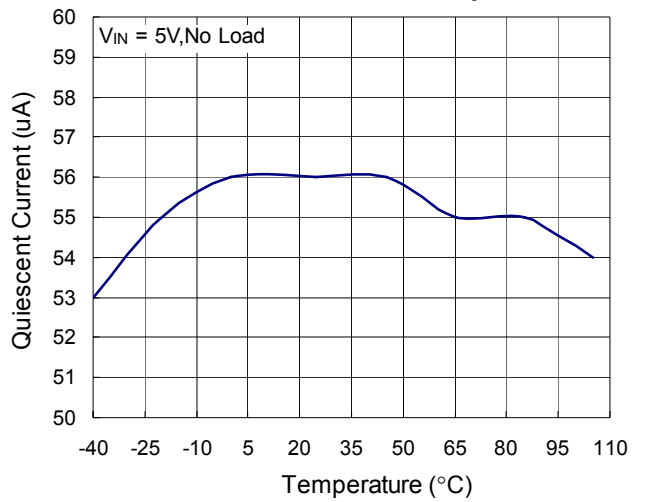

Shutdown Current vs. Input Voltage

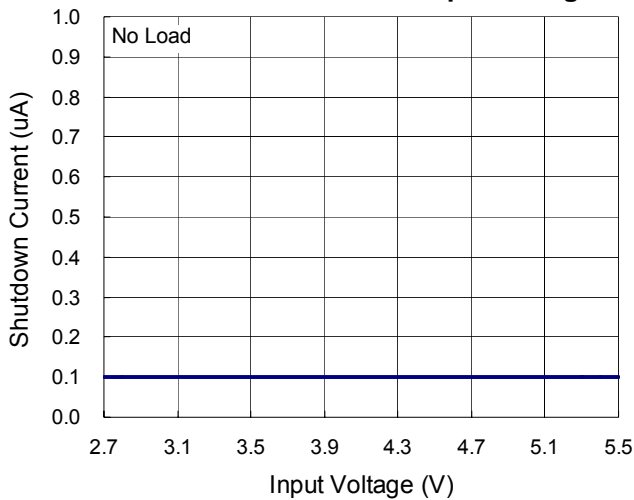

Shutdown Current vs. Temperature

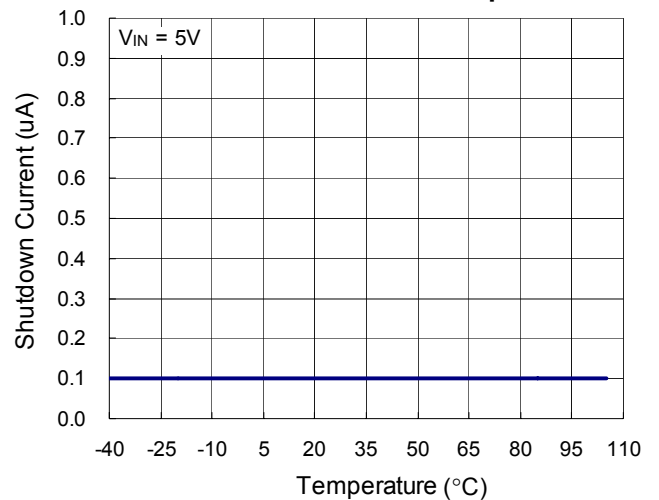

Output Voltage vs. Output Current

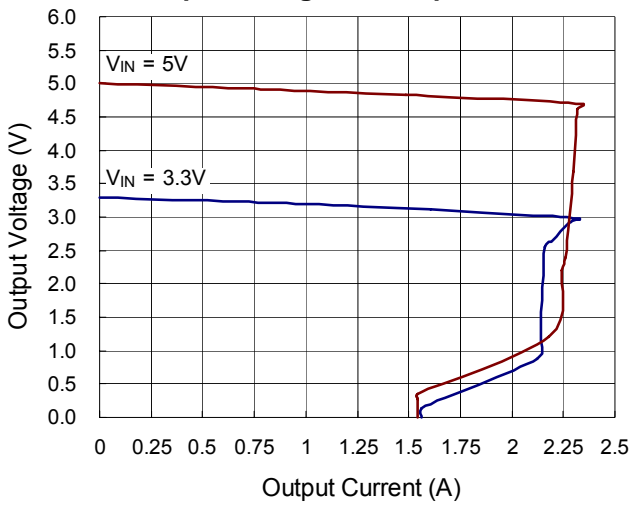

UVLO Threshold vs. Temperature

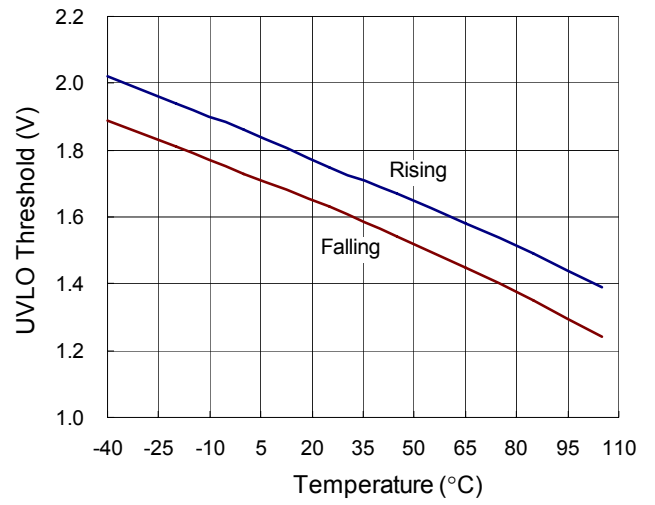

Current Limit vs. Input Voltage

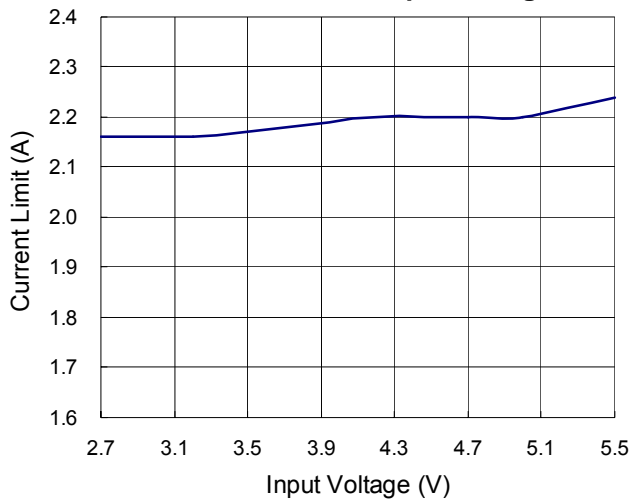

Current Limit vs. Temperature

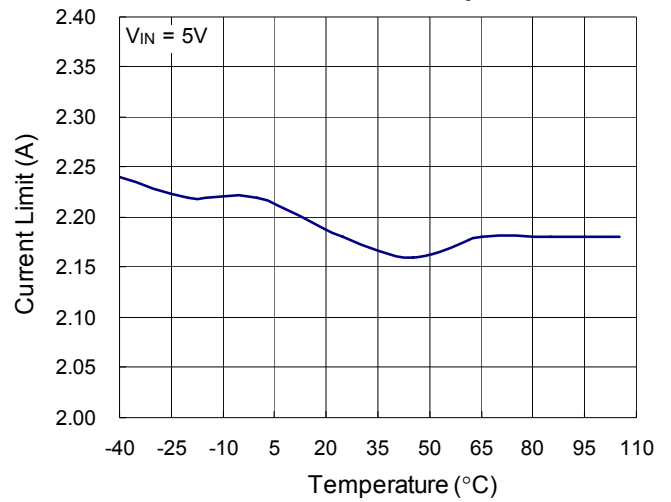

Short Current vs. Input Voltage

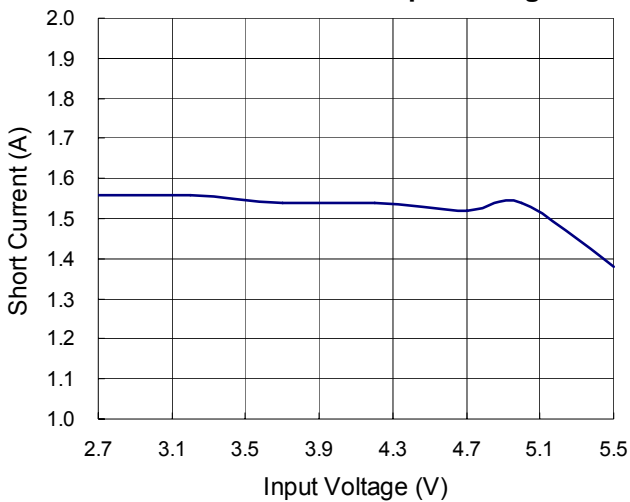

Short Current vs. Temperature

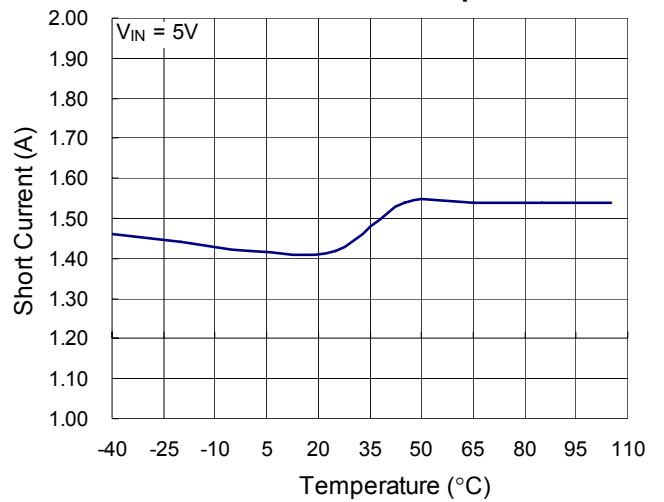

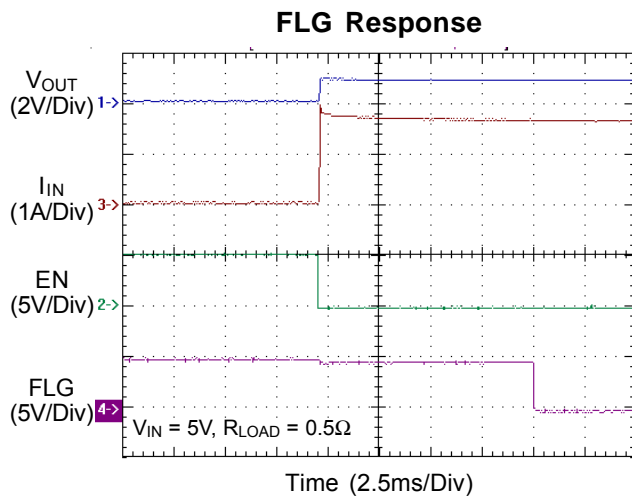
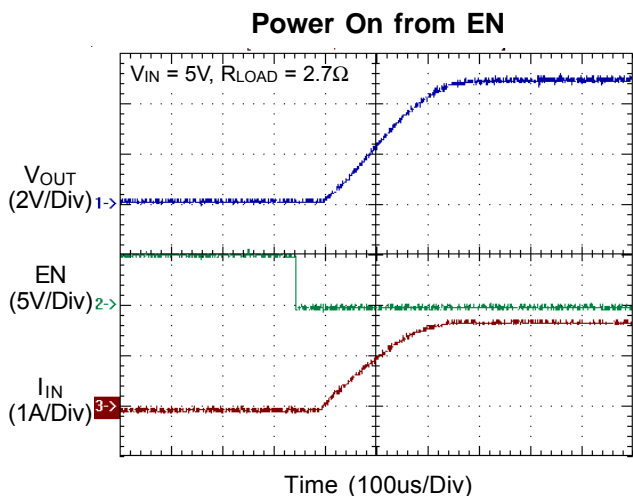
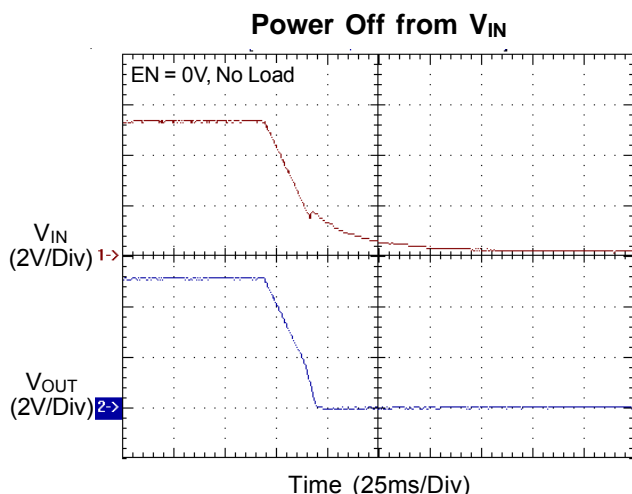
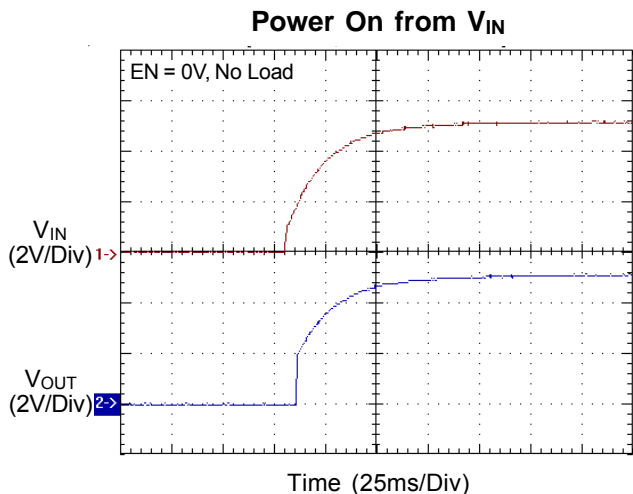
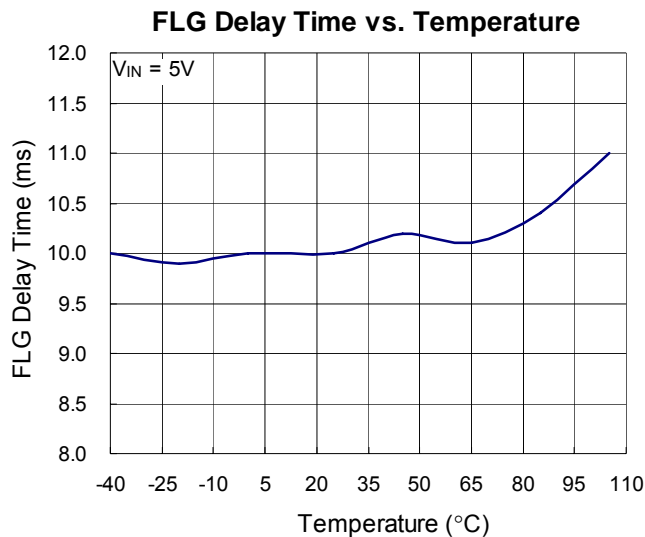
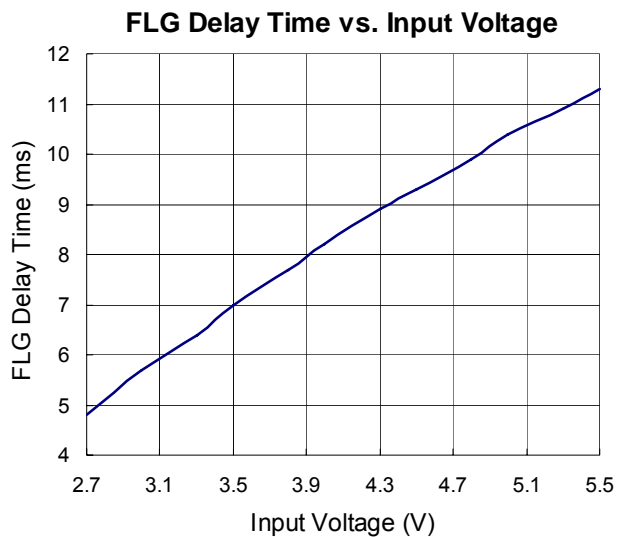

Applications Information

The RT9715 is a single N-MOSFET high-side power switches with enable input, optimized for self-powered and bus-powered Universal Serial Bus (USB) applications. The RT9715 is equipped with a charge pump circuitry to drive the internal N-MOSFET switch; the switch's low $R_{DS(ON)}$, 90m Ω , meets USB voltage drop requirements; and a flag output is available to indicate fault conditions to the local USB controller.

Input and Output

V_{IN} (input) is the power source connection to the internal circuitry and the drain of the MOSFET. V_{OUT} (output) is the source of the MOSFET. In a typical application, current flows through the switch from V_{IN} to V_{OUT} toward the load. If V_{OUT} is greater than V_{IN} , current will flow from V_{OUT} to V_{IN} since the MOSFET is bidirectional when on.

Unlike a normal MOSFET, there is no parasitic body diode between drain and source of the MOSFET, the RT9715 prevents reverse current flow if V_{OUT} is externally forced to a higher voltage than V_{IN} when the chip is disabled ($V_{EN} < 0.8V$ or $V_{EN} > 2V$).

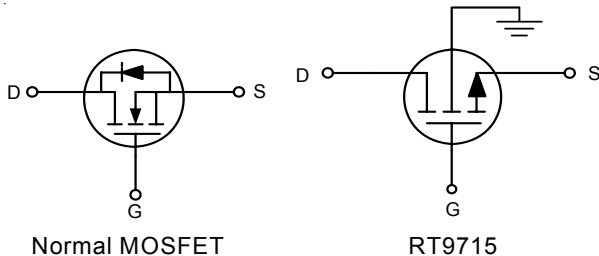

Chip Enable Input

The switch will be disabled when the EN/\overline{EN} pin is in a logic low/high condition. During this condition, the internal circuitry and MOSFET will be turned off, reducing the supply current to 0.1 μ A typical. Floating the EN/\overline{EN} may cause unpredictable operation. EN should not be allowed to go negative with respect to GND. The EN/\overline{EN} pin may be directly tied to V_{IN} (GND) to keep the part on.

Soft Start for Hot Plug-In Applications

In order to eliminate the upstream voltage droop caused by the large inrush current during hot-plug events, the "soft-start" feature effectively isolates the power source from extremely large capacitive loads, satisfying the USB voltage droop requirements.

Fault Flag

The RT9715 series provides a \overline{FLG} signal pin which is an N-Channel open drain MOSFET output. This open drain output goes low when current limit or the die temperature exceeds 120°C approximately. The \overline{FLG} output is capable of sinking a 10mA load to typically 200mV above ground. The \overline{FLG} pin requires a pull-up resistor, this resistor should be large in value to reduce energy drain. A 100k Ω pull-up resistor works well for most applications. In the case of an over-current condition, \overline{FLG} will be asserted only after the flag response delay time, t_D , has elapsed. This ensures that \overline{FLG} is asserted only upon valid over-current conditions and that erroneous error reporting is eliminated.

For example, false over-current conditions may occur during hot-plug events when extremely large capacitive loads are connected and causes a high transient inrush current that exceeds the current limit threshold. The \overline{FLG} response delay time t_D is typically 12ms.

Under-Voltage Lockout

Under-voltage lockout (UVLO) prevents the MOSFET switch from turning on until input the voltage exceeds approximately 1.7V. If input voltage drops below approximately 1.3V, UVLO turns off the MOSFET switch. Under-voltage detection functions only when the switch is enabled.

Current Limiting and Short-Circuit Protection

The current limit circuitry prevents damage to the MOSFET switch and the hub downstream port but can deliver load current up to the current limit threshold of typically 2A through the switch of the RT9715A/B, 1.5A for RT9715C/D, 1.1A for RT9715E/F and 0.7A for RT9715G/H respectively. When a heavy load or short circuit is applied to an enabled switch, a large transient current may flow until the current limit circuitry responds. Once this current limit threshold is exceeded, the device enters constant current mode until the thermal shutdown occurs or the fault is removed.

Thermal Shutdown

Thermal protection limits the power dissipation in RT9715. When the operation junction temperature exceeds 120°C, the OTP circuit starts the thermal shutdown function and

turns the pass element off. The pass element turn on again after the junction temperature cools to 80°C. The RT9715 lowers its OTP trip level from 120°C to 100°C when output short circuit occurs ($V_{OUT} < 1V$) as shown in Figure 1.

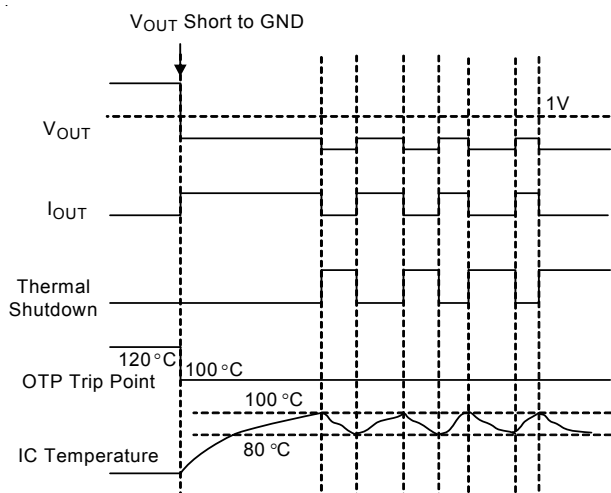

Figure 1. Short Circuit Thermal Folded Back Protection when Output Short Circuit Occurs (Patent)

Power Dissipation

The junction temperature of the RT9715 series depend on several factors such as the load, PCB layout, ambient temperature and package type. The output pin of the RT9715 can deliver the current of up to 2A (RT9715A/B), 1.5A (RT9715C/D), 1.1A (RT9715E/F) and 0.7A (RT9715G/H) respectively over the full operating junction temperature range. However, the maximum output current must be derated at higher ambient temperature to ensure the junction temperature does not exceed 100°C. With all possible conditions, the junction temperature must be within the range specified under operating conditions. Power dissipation can be calculated based on the output current and the $R_{DS(ON)}$ of the switch as below.

$$P_D = R_{DS(ON)} \times I_{OUT}^2$$

Although the devices are rated for 2A, 1.5A, 1.1A and 0.7A of output current, but the application may limit the amount of output current based on the total power dissipation and the ambient temperature. The final operating junction temperature for any set of conditions can be estimated by the following thermal equation :

$$P_{D(MAX)} = (T_{J(MAX)} - T_A) / \theta_{JA}$$

Where $T_{J(MAX)}$ is the maximum junction temperature of the die (100°C) and T_A is the maximum ambient temperature.

The junction to ambient thermal resistance (θ_{JA}) for SOT-23-5/TSOT-23-5, SOP-8/MSOP-8 and WDFM-8L 3x3 packages at recommended minimum footprint are 250°C/W, 160°C/W and 108°C/W respectively (θ_{JA} is layout dependent).

Universal Serial Bus (USB) & Power Distribution

The goal of USB is to enable device from different vendors to interoperate in an open architecture. USB features include ease of use for the end user, a wide range of workloads and applications, robustness, synergy with the PC industry, and low-cost implementation. Benefits include self-identifying peripherals, dynamically attachable and reconfigurable peripherals, multiple connections (support for concurrent operation of many devices), support for as many as 127 physical devices, and compatibility with PC Plug-and-Play architecture.

The Universal Serial Bus connects USB devices with a USB host: each USB system has one USB host. USB devices are classified either as hubs, which provide additional attachment points to the USB, or as functions, which provide capabilities to the system (for example, a digital joystick). Hub devices are then classified as either Bus-Power Hubs or Self-Powered Hubs.

A Bus-Powered Hub draws all of the power to any internal functions and downstream ports from the USB connector power pins. The hub may draw up to 500mA from the upstream device. External ports in a Bus-Powered Hub can supply up to 100mA per port, with a maximum of four external ports.

Self-Powered Hub power for the internal functions and downstream ports does not come from the USB, although the USB interface may draw up to 100mA from its upstream connect, to allow the interface to function when the remainder of the hub is powered down. The hub must be able to supply up to 500mA on all of its external downstream ports. Please refer to Universal Serial Specification Revision 2.0 for more details on designing compliant USB hub and host systems.

Over-Current protection devices such as fuses and PTC resistors (also called polyfuse or polyswitch) have slow trip times, high on-resistance, and lack the necessary circuitry for USB-required fault reporting.

The faster trip time of the RT9715 power distribution allows designers to design hubs that can operate through faults. The RT9715 provides low on-resistance and internal fault-reporting circuitry to meet voltage regulation and fault notification requirements.

Because the devices are also power switches, the designer of self-powered hubs has the flexibility to turn off power to output ports. Unlike a normal MOSFET, the devices have controlled rise and fall times to provide the needed inrush current limiting required for the bus-powered hub power switch.

Supply Filter/Bypass Capacitor

A 1uF low-ESR ceramic capacitor from V_{IN} to GND, located at the device is strongly recommended to prevent the input voltage drooping during hot-plug events. However, higher capacitor values will further reduce the voltage droop on the input. Furthermore, without the bypass capacitor, an output short may cause sufficient ringing on the input (from source lead inductance) to destroy the internal control circuitry. The input transient must not exceed 6V of the absolute maximum supply voltage even for a short duration.

Output Filter Capacitor

A low-ESR 150uF aluminum electrolytic or tantalum between V_{OUT} and GND is strongly recommended to meet the 330mV maximum droop requirement in the hub V_{BUS} (Per USB 2.0, output ports must have a minimum 120uF of low-ESR bulk capacitance per hub). Standard bypass methods should be used to minimize inductance and resistance between the bypass capacitor and the downstream connector to reduce EMI and decouple voltage droop caused when downstream cables are hot-insertion transients. Ferrite beads in series with V_{BUS} , the ground line and the 0.1uF bypass capacitors at the power connector pins are recommended for EMI and ESD protection. The bypass capacitor itself should have a low dissipation factor to allow decoupling at higher frequencies.

Voltage Drop

The USB specification states a minimum port-output voltage in two locations on the bus, 4.75V out of a Self-Powered Hub port and 4.40V out of a Bus-Powered Hub port. As with the Self-Powered Hub, all resistive voltage drops for

the Bus-Powered Hub must be accounted for to guarantee voltage regulation (see Figure 7-47 of Universal Serial Specification Revision 2.0).

The following calculation determines $V_{OUT(MIN)}$ for multiple ports (N_{PORTS}) ganged together through one switch (if using one switch per port, N_{PORTS} is equal to 1) :

$$V_{OUT(MIN)} = 4.75V - [I_I \times (4 \times R_{CONN} + 2 \times R_{CABLE})] - (0.1A \times N_{PORTS} \times R_{SWITCH}) - V_{PCB}$$

Where

R_{CONN} = Resistance of connector contacts
(two contacts per connector)

R_{CABLE} = Resistance of upstream cable wires
(one 5V and one GND)

R_{SWITCH} = Resistance of power switch
(90mΩ typical for RT9715)

V_{PCB} = PCB voltage drop

The USB specification defines the maximum resistance per contact (R_{CONN}) of the USB connector to be 30mΩ and the drop across the PCB and switch to be 100mV. This basically leaves two variables in the equation: the resistance of the switch and the resistance of the cable.

If the hub consumes the maximum current (I_I) of 500mA, the maximum resistance of the cable is 90mΩ.

The resistance of the switch is defined as follows :

$$R_{SWITCH} = \{ 4.75V - 4.4V - [0.5A \times (4 \times 30m\Omega + 2 \times 90m\Omega)] - V_{PCB} \} \div (0.1A \times N_{PORTS})$$

$$= (200mV - V_{PCB}) \div (0.1A \times N_{PORTS})$$

If the voltage drop across the PCB is limited to 100mV, the maximum resistance for the switch is 250mΩ for four ports ganged together. The RT9715, with its maximum 100mΩ on-resistance over temperature, can fit the demand of this requirement.

Thermal Considerations

For continuous operation, do not exceed absolute maximum operation junction temperature. The maximum power dissipation depends on the thermal resistance of IC package, PCB layout, the rate of surroundings airflow and temperature difference between junction to ambient. The

maximum power dissipation can be calculated by following formula :

$$P_{D(MAX)} = (T_{J(MAX)} - T_A) / \theta_{JA}$$

Where $T_{J(MAX)}$ is the maximum operation junction temperature 100°C, T_A is the ambient temperature and the θ_{JA} is the junction to ambient thermal resistance.

For recommended operating conditions specification of RT9715, where $T_{J(MAX)}$ is the maximum junction temperature of the die (100°C) and T_A is the maximum ambient temperature. The junction to ambient thermal resistance θ_{JA} is layout dependent. For SOT-23-5 packages, the thermal resistance θ_{JA} is 250°C/W on the standard JEDEC 51-3 single-layer thermal test board. And for SOP-8 and MSOP-8 packages, the thermal resistance θ_{JA} is 160°C/W. The maximum power dissipation at $T_A = 25^\circ\text{C}$ can be calculated by following formula :

$$P_{D(MAX)} = (100^\circ\text{C} - 25^\circ\text{C}) / (250^\circ\text{C/W}) = 0.3\text{W for SOT-23-5 packages}$$

$$P_{D(MAX)} = (100^\circ\text{C} - 25^\circ\text{C}) / (160^\circ\text{C/W}) = 0.469\text{W for SOP-8/MSOP-8 packages}$$

$$P_{D(MAX)} = (100^\circ\text{C} - 25^\circ\text{C}) / (108^\circ\text{C/W}) = 0.694\text{W for WDFN-8L 3x3 packages}$$

The maximum power dissipation depends on operating ambient temperature for fixed $T_{J(MAX)}$ and thermal resistance θ_{JA} . For RT9715 packages, the Figure 2 of derating curves allows the designer to see the effect of rising ambient temperature on the maximum power allowed.

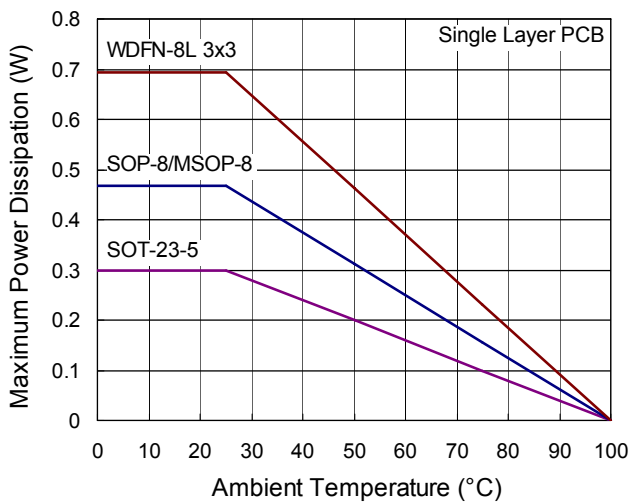

Figure 2. Derating Curves for RT9715 Package

PCB Layout Guide

In order to meet the voltage drop, droop, and EMI requirements, careful PCB layout is necessary. The following guidelines must be followed :

- ▶ Locate the ceramic bypass capacitors as close as possible to the VIN pins of the RT9715.
- ▶ Place a ground plane under all circuitry to lower both resistance and inductance and improve DC and transient performance (Use a separate ground and power plans if possible).
- ▶ Keep all V_{BUS} traces as short as possible and use at least 50-mil, 2 ounce copper for all V_{BUS} traces.
- ▶ Avoid vias as much as possible. If vias are necessary, make them as large as feasible.
- ▶ Place cuts in the ground plane between ports to help reduce the coupling of transients between ports.
- ▶ Locate the output capacitor and ferrite beads as close to the USB connectors as possible to lower impedance (mainly inductance) between the port and the capacitor and improve transient load performance.
- ▶ Locate the RT9715 as close as possible to the output port to limit switching noise.

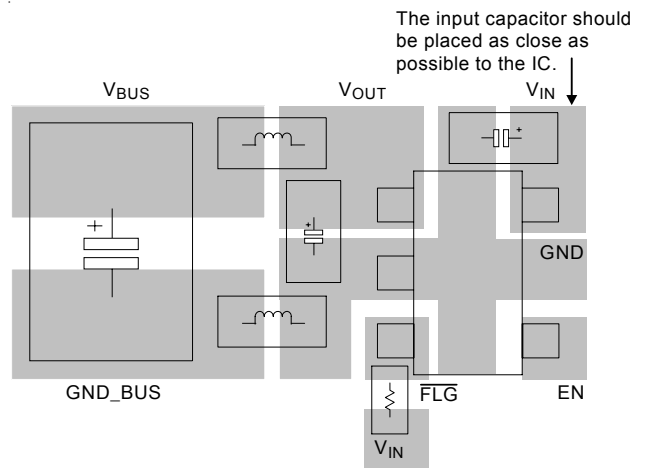
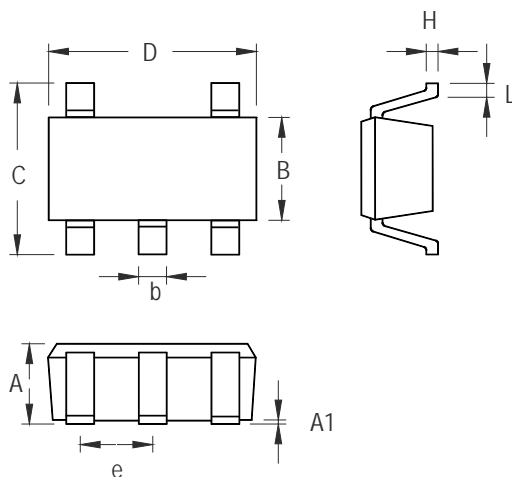

Figure 3

Outline Dimension



Symbol	Dimensions In Millimeters		Dimensions In Inches	
	Min	Max	Min	Max
A	0.889	1.295	0.035	0.051
A1	0.000	0.152	0.000	0.006
B	1.397	1.803	0.055	0.071
b	0.356	0.559	0.014	0.022
C	2.591	2.997	0.102	0.118
D	2.692	3.099	0.106	0.122
e	0.838	1.041	0.033	0.041
H	0.080	0.254	0.003	0.010
L	0.300	0.610	0.012	0.024

SOT-23-5 Surface Mount Package

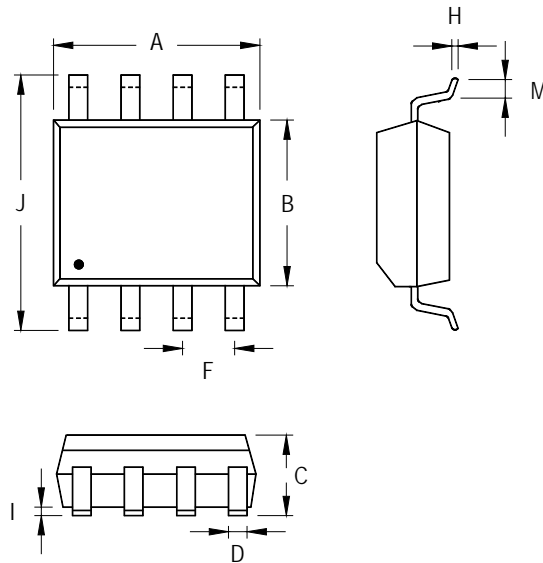

Symbol	Dimensions In Millimeters		Dimensions In Inches	
	Min	Max	Min	Max
A	4.801	5.004	0.189	0.197
B	3.810	3.988	0.150	0.157
C	1.346	1.753	0.053	0.069
D	0.330	0.508	0.013	0.020
F	1.194	1.346	0.047	0.053
H	0.170	0.254	0.007	0.010
I	0.050	0.254	0.002	0.010
J	5.791	6.200	0.228	0.244
M	0.400	1.270	0.016	0.050

8-Lead SOP Plastic Package

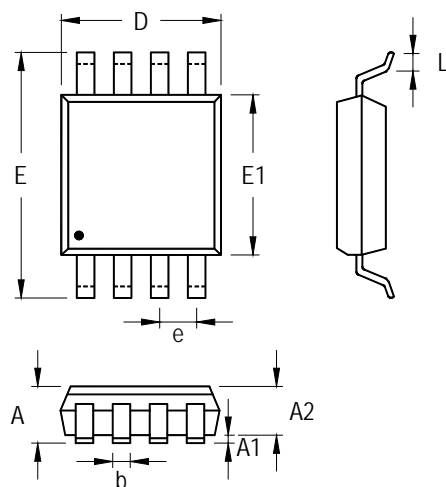

Symbol	Dimensions In Millimeters		Dimensions In Inches	
	Min	Max	Min	Max
A	0.810	1.100	0.032	0.043
A1	0.000	0.150	0.000	0.006
A2	0.750	0.950	0.030	0.037
b	0.220	0.380	0.009	0.015
D	2.900	3.100	0.114	0.122
e	0.650		0.026	
E	4.800	5.000	0.189	0.197
E1	2.900	3.100	0.114	0.122
L	0.400	0.800	0.016	0.031

8-Lead MSOP Plastic Package

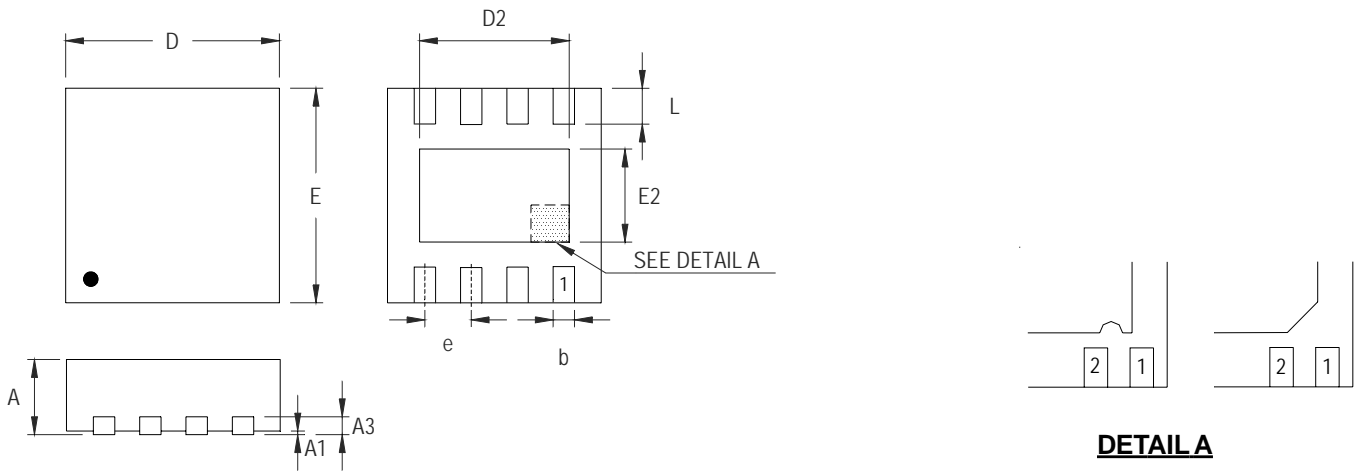

DETAIL A

Pin #1 ID and Tie Bar Mark Options

Note : The configuration of the Pin #1 identifier is optional, but must be located within the zone indicated.

Symbol	Dimensions In Millimeters		Dimensions In Inches	
	Min	Max	Min	Max
A	0.700	0.800	0.028	0.031
A1	0.000	0.050	0.000	0.002
A3	0.175	0.250	0.007	0.010
b	0.200	0.300	0.008	0.012
D	2.950	3.050	0.116	0.120
D2	2.100	2.350	0.083	0.093
E	2.950	3.050	0.116	0.120
E2	1.350	1.600	0.053	0.063
e	0.650		0.026	
L	0.425	0.525	0.017	0.021

W-Type 8L DFN 3x3 Package

Richtek Technology Corporation

Headquarter
 5F, No. 20, Taiyuen Street, Chupei City
 Hsinchu, Taiwan, R.O.C.
 Tel: (8863)5526789 Fax: (8863)5526611



Richtek Technology Corporation

Taipei Office (Marketing)
 5F, No. 95, Minchiuan Road, Hsintien City
 Taipei County, Taiwan, R.O.C.
 Tel: (8862)86672399 Fax: (8862)86672377
 Email: marketing@richtek.com

Information that is provided by Richtek Technology Corporation is believed to be accurate and reliable. Richtek reserves the right to make any change in circuit design, specification or other related things if necessary without notice at any time. No third party intellectual property infringement of the applications should be guaranteed by users when integrating Richtek products into any application. No legal responsibility for any said applications is assumed by Richtek.

Looking for pricing, stock, or lifecycle information?

Click below to explore more details on WIN SOURCE:

-  [View RT9715GGS on WIN SOURCE](#)
-  [Richtek USA Inc. Information](#)

Optimize Your Supply Chain with WIN SOURCE Solutions

-  Global Sourcing Solution
-  Obsolete Management
-  Cost Control Management
-  Shortage Management
-  Alternative Solution
-  Excess Inventory Management