



**THE DATASHEET OF
NCN4557MTG**



NCN4557

1.8 V/3.0 V Dual SIM/SAM/ Smart Card Power Supply and Level Shifter

The NCN4557 is a dual interface analog circuit designed to translate the voltages between SIM, SAM or Smart Cards and a microcontroller (or similar control device). It integrates two LDOs for power conversion and three level shifters per channel allowing the management of two independent chip cards. The device fulfills the ISO7816 and EMV smart card interface requirements as well as the GSM and 3G mobile standard. Due to a built-in sequencer, the device enables automatic activation and deactivation. Through the ENABLE pin a low current shutdown mode can be activated extending the battery life.

The card power supply voltage (1.8 V or 3.0 V) and the card socket A or B are selected using two dedicated pins (SEL0 & SEL1).

Features

- Supports 1.8 V or 3.0 V Operating SIM/SAM/Smart Cards
- The LDOs are able to Supply more than 50 mA Under 1.8 V and 3.0 V
- Built-in Active and Passive Pullup Resistor for I/O and CRD_IOA/B Pins in Both Directions
- All Pins are Fully ESD Protected According to ISO-7816 Specifications – ESD Protection on Card Pins in Excess of 8.0 kV (JEDEC HBM)
- Built-in Sequencer for Activation and Deactivation
- Supports up to more than 5.0 MHz Clock
- Very Compact Low-Profile 3x3 QFN-16 Package
- These are Pb-Free Devices*

Applications

- SIM Card Interface Circuit for 2G, 2.5G and 3G Mobile Phones
- Wireless PC/Laptop Cards (PCMCIA Cards)
- POS Terminals (SAM Card Interfaces)
- Smart Card Readers

*For additional information on our Pb-Free strategy and soldering details, please download the ON Semiconductor Soldering and Mounting Techniques Reference Manual, SOLDERRM/D.



ON Semiconductor®

<http://onsemi.com>

MARKING DIAGRAM



QFN16
MT SUFFIX
CASE 488AK

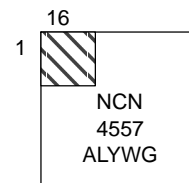

A = Assembly Location
L = Wafer Lot
Y = Year
W = Work Week
G or ■ = Pb-Free Package

ORDERING INFORMATION

See detailed ordering and shipping information in the package dimensions section on page 11 of this data sheet.

NCN4557

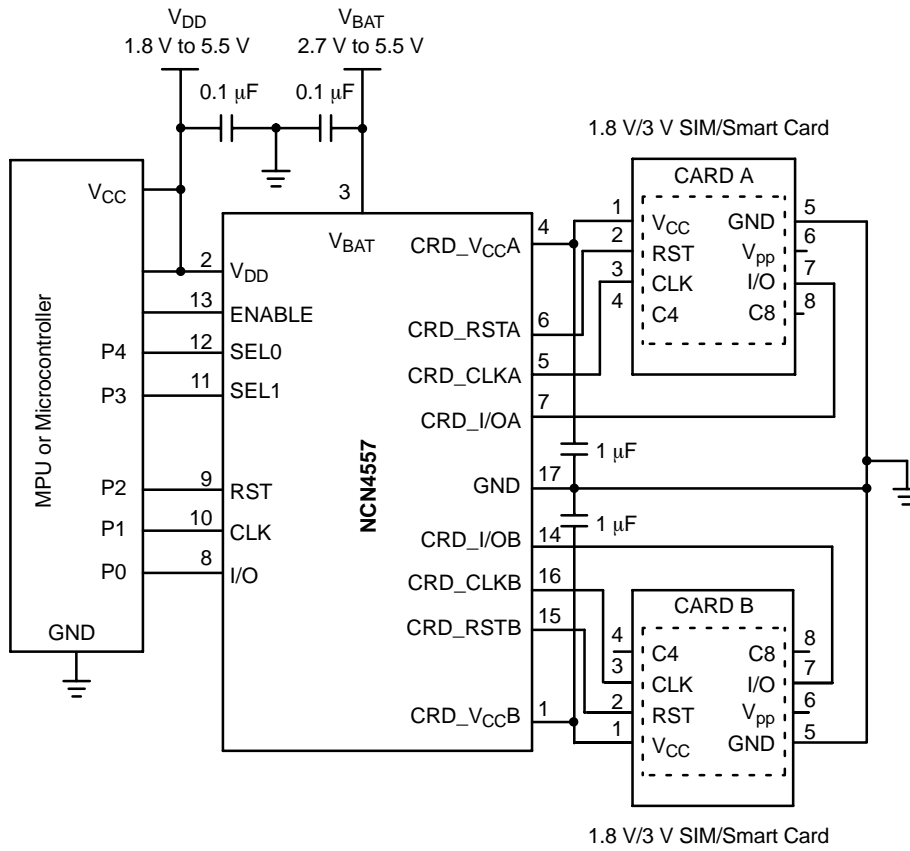

Figure 1. Typical Interface Application

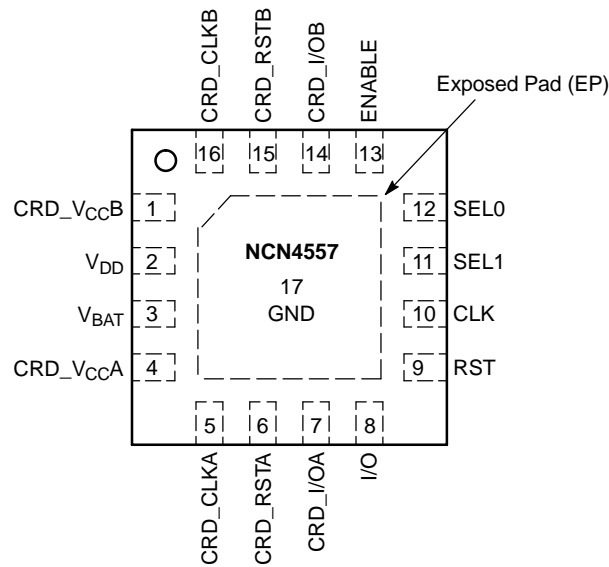

Figure 2. QFN-16 Pinout (Top View)

NCN4557

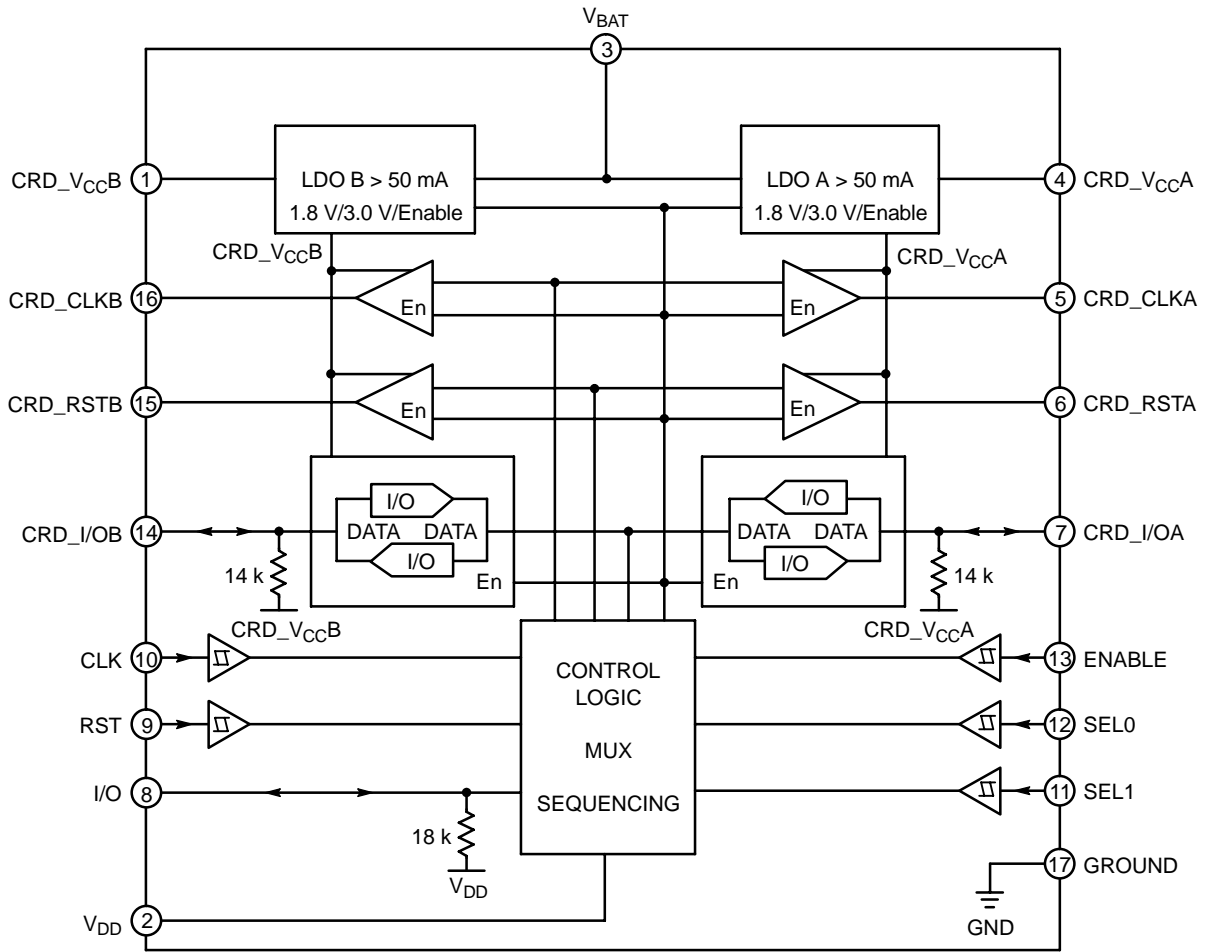

Figure 3. NCN4557 Block Diagram

NCN4557

PIN DESCRIPTIONS

PIN	Name	Type	Description
1	CRD_VCCB	POWER	This pin is connected to the Card power supply pin (C1) (Card B). The corresponding LDO is programmable using the pins SEL0, SEL1 and ENABLE to provide 1.8 V, 3.0 V or 0 V (disable). CRD_VCCB can not be active when CRD_VCCA is active and conversely.
2	VDD	POWER	This pin is connected to the controller power supply. It configures the level shifter input stage to accept the signal coming from the microcontroller. A 0.1 μ F capacitor shall be used to bypass the power supply voltage. When VDD is below 1.5 V typical CRD_VCCA and B are disabled; the NCN4557 comes into a shutdown mode.
3	VBAT	POWER	DC/DC converter power supply input shared by the LDOs A & B. This pin has to be bypassed by a 0.1 μ F capacitor.
4	CRD_VCCA	POWER	This pin is connected to the Card power supply pin (C1) (Card A). The corresponding LDO is programmable using the pins SEL0, SEL1 and ENABLE to provide 1.8 V, 3.0 V or 0 V (disable). CRD_VCCA can not be active when CRD_VCCB is active and conversely.
5	CRD_CLKA	OUTPUT	This pin is connected to the clock pin (C3) of the card connector A. The clock (CLK) signal comes from the external clock generator (standalone clock source or microcontroller). The internal level shifter adapts the voltage levels CLK to CRD_CLKA. An internal active pull-down NMOS device maintains this pin to Ground during either the CRD_VCCA start-up sequence, or when CRD_VCCA = 0 V.
6	CRD_RSTA	OUTPUT	This pin is connected to the RESET pin (C2) of the card connector A. A level translator adapts the RESET signal from the microcontroller to the external card A. The output current is internally limited to 15 mA max. Similarly to the CRD_CLK A or B pins this pin is maintained Low when CRD_VCCA = 0 V and during the corresponding LDO transient phase of power-up.
7	CRD_I/OA	INPUT / OUTPUT	This pin handles the connection to the serial I/O pin (C7) of the card connector A. A bidirectional level translator adapts the serial I/O signal between the card and the micro-controller. A 14 k Ω (typical) pull-up resistor provides a High Impedance state to the card I/O link; during the operating phase, a dynamic pull-up circuit is activated making the CRD_I/OA rise time compliant with the ISO7816, EMV, GSM and related standards. An internal active pull-down MOS device forces this pin to Ground during either the CRD_VCCA start-up sequence or when CRD_VCCA = 0 V. The CRD_I/OA pin is internally limited by a 15 mA max current.
8	I/O	INPUT / OUTPUT	This pin is connected to an external microcontroller or cellular phone management unit (Baseband circuit or PMU). A bidirectional level translator adapts the serial I/O signal between the smart card A or B and the controller. Only one card, the selected card, communicates through the bidirectional I/O interface. A built-in 18 k Ω typical resistor provides a high impedance state when the interface is not activated. An additional dynamic pullup circuit accelerates the I/O rise time making the bidirectional channel perfectly balanced in regards to the standard rise time requirements.
9	RST	INPUT	The RESET signal present at this pin is connected to the card through the internal level shifter which translates the levels according to the CRD_VCCA or B programmed value.
10	CLK	INPUT	The clock signal, coming from the external controller, must have a Duty Cycle within the Min/Max values defined by the specification (typically 50%). The built-in level shifter translates the input signal to the external card CLK input.
11	SEL1	INPUT	SEL1 allows the selection of the Card A or B (Table 1). SEL1 = Low \rightarrow Card A selected SEL1 = High \rightarrow Card B selected
12	SEL0	INPUT	SEL0 allows programming CRD_VCCA or B (1.8 V or 3.0 V) (Table 1). SEL0 = Low \rightarrow CRD_VCCA/B = 1.8 V SEL0 = High \rightarrow CRD_VCCA/B = 3.0 V
13	ENABLE	INPUT	Power Up and Down pin: ENABLE = Low \rightarrow Low current shutdown mode activated ENABLE = High \rightarrow Normal Operation A Low level on this pin switches off the card interface.
14	CRD_I/OB	INPUT / OUTPUT	This pin handles the connection to the serial I/O pin (C7) of the card connector B. A bidirectional level translator adapts the serial I/O signal between the card and the micro-controller. A 14 k Ω (typical) pull-up resistor provides a High Impedance state to the card I/O link; during the operating phase a dynamic pull-up circuit is activated making the CRD_I/OB rise time compliant with the ISO7816, EMV, GSM and related standards. An internal active pulldown MOS device forces this pin to Ground during either the CRD_VCCB start-up sequence or when CRD_VCCB = 0 V. The CRD_I/OB pin is internally limited by a 15 mA maximum current.
15	CRD_RSTB	OUTPUT	This pin is connected to the RESET pin of the card connector B. A level translator adapts the RESET signal from the microcontroller to the external card B. The output current is internally limited by a 15 mA max current. Similarly to the CRD_CLK A or B pins this pin is maintained Low when CRD_VCCB = 0 V and during the corresponding LDO transient phase of powerup.
16	CRD_CLKB	OUTPUT	This pin is connected to the clock pin (C3) of the card connector B. The clock (CLK) signal comes from the external clock generator (standalone clock source or microcontroller). The internal level shifter adapts the voltage levels CLK to CRD_CLKB. An internal active pull down NMOS device maintains this pin to Ground during either the CRD_VCCB start-up sequence, or when CRD_VCCB = 0 V.
17	GND	GND	This pin number is the Exposed Pad which is the electrical Ground of the device. It must be soldered to the PCB ground plane.

NCN4557

POWER SUPPLY SECTION (–40°C to +85°C)

Pin	Symbol	Rating	Min	Typ	Max	Unit
3	V _{BAT}	Power Supply	2.7		5.5	V
3	I _{V_{BAT}}	Operating current CRD_V _{CCA} = 3.0 V, CRD_V _{CCB} = 0 V, I _{CCA & B} = 0 mA CRD_V _{CCA} = 1.8 V, CRD_V _{CCB} = 0 V, I _{CCA & B} = 0 mA CRD_V _{CCA} = 0 V, CRD_V _{CCB} = 3.0 V, I _{CCA & B} = 0 mA CRD_V _{CCA} = 0 V, CRD_V _{CCB} = 1.8 V, I _{CCA & B} = 0 mA		26 25 26 25	80 80 80 80	μA
3	I _{V_{BAT}_SD}	Shutdown current – ENABLE = Low			3	μA
2	V _{DD}	Operating Voltage	1.8		5.5	V
2	I _{V_{DD}}	Operating Current (CLK & RST Low)		0.1	2	μA
2	I _{V_{DD}_SD}	Shutdown Current – ENABLE = Low		0.05	1	μA
2	V _{DD}	Undervoltage Lockout	0.6		1.5	V
1,4	CRD_V _{CCA} or B	3.0 V Mode, V _{BAT} = 3.3 V to 5.5 V, I _{CRD_V_{CC}} = 0 mA to 50 mA 1.8 V Mode, V _{BAT} = 2.7 V to 5.5 V, I _{CRD_V_{CC}} = 0 mA to 50 mA	2.75 1.65	3.0 1.8	3.25 1.95	V
1,4	I _{CRD_V_{CC}_SC}	Short –Circuit Current – CRD_V _{CC} Shorted to GND, T _A = 25°C		50	175	mA
7,13,14		Channel Turn–on Time I _{CCA} or B = 0 mA, ENABLE rise edge to CRD_I/OA or B rise edge		0.8	2.5	ms

NOTE: Device will meet the specifications after thermal equilibrium has been established when mounted in a test socket or printed circuit board with maintained transverse airflow greater than 500 lfm. Electrical parameters are guaranteed only over the declared operating temperature range. Functional operation of the device exceeding these conditions is not implied. Device specification limit values are applied individually under normal operating conditions and not valid simultaneously.

DIGITAL INPUT/OUTPUT SECTION CLK, RST, I/O, ENABLE, SEL0, SEL1 (–40°C to +85°C)

Pin	Symbol	Rating	Min	Typ	Max	Unit
9,10	V _{IH} V _{IL}	High Level Input Voltage (RST, CLK) Low Level Input Voltage (RST, CLK)	0.85 * V _{DD}		V _{DD} 0.15 * V _{DD}	V
11,12,13	V _{IH} V _{IL}	High Level Input Voltage (ENABLE, SEL0, SEL1) Low Level Input Voltage (ENABLE, SEL0, SEL1)	0.85 * V _{DD}		V _{DD} 0.15 * V _{DD}	V
9,10,11, 12,13	I _{IH} , I _{IL}	Input current (RST, CLK, ENABLE, SEL0, SEL1)	–1		1	μA
8	V _{OH_I/O} V _{OL_I/O}	High Level Output Voltage (CRD_I/O = CRD_V _{CC} , I _{OH_I/O} = –20 μA) Low Level Output Voltage (CRD_I/O = 0 V, I _{OL_I/O} = 500 μA)	0.75 * V _{DD}		V _{DD} 0.3	V
8	t _R , t _F	Rise and Fall times (I/O), C _{out} = 30 pF			0.8	μs
8	R _{pu_I/O}	I/O Pullup Resistor	12	18	24	kΩ

NOTE: Device will meet the specifications after thermal equilibrium has been established when mounted in a test socket or printed circuit board with maintained transverse airflow greater than 500 lfm. Electrical parameters are guaranteed only over the declared operating temperature range. Functional operation of the device exceeding these conditions is not implied. Device specification limit values are applied individually under normal operating conditions and not valid simultaneously.

CARD INTERFACE SECTION (–40°C to +85°C)

Pin	Symbol	Rating	Min	Typ	Max	Unit
6,15	CRD_RSTA CRD_RSTB	<p>CRD_V_{CC} = +3 V Output RESET V_{OH} @ I_{CRD_rst} = –20 μA Output RESET V_{OL} @ I_{CRD_rst} = +200 μA Output RESET Rise Time @ C_{out} = 30 pF Output RESET Fall Time @ C_{out} = 30 pF</p> <p>CRD_V_{CC} = +1.8 V Output RESET V_{OH} @ I_{CRD_rst} = –20 μA Output RESET V_{OL} @ I_{CRD_rst} = +200 μA Output RESET Rise Time @ C_{out} = 30 pF Output RESET Fall Time @ C_{out} = 30 pF</p>	<p>0.9 * CRD_V_{CC} 0</p> <p>0.9 * CRD_V_{CC} 0</p>		<p>CRD_V_{CC} 0.3 0.8 0.8</p> <p>CRD_V_{CC} 0.3 0.8 0.8</p>	<p>V V μs μs</p> <p>V V μs μs</p>
5,16	CRD_CLKA CRD_CLKB	<p>CRD_V_{CC} = +3 V Output Duty Cycle Max Output Frequency Output V_{OH} @ I_{CRD_clk} = –20 μA Output V_{OL} @ I_{CRD_clk} = +200 μA Output CRD_CLK Rise Time @ C_{out} = 30 pF Output CRD_CLK Fall Time @ C_{out} = 30 pF</p> <p>CRD_V_{CC} = +1.8 V Output Duty Cycle Max Output Frequency Output V_{OH} @ I_{CRD_clk} = –20 μA Output V_{OL} @ I_{CRD_clk} = +200 μA Output CRD_CLK Rise Time @ C_{out} = 30 pF Output CRD_CLK Fall Time @ C_{out} = 30 pF</p>	<p>40 5 0.9 * CRD_V_{CC} 0</p> <p>40 5 0.9 * CRD_V_{CC} 0</p>		<p>60 CRD_V_{CC} 0.3 18 18</p> <p>60 CRD_V_{CC} 0.3 18 18</p>	<p>% MHz V V ns ns</p> <p>% MHz V V ns ns</p>
7,14	CRD_I/OA CRD_I/OB	<p>CRD_V_{CC} = +3 V Output V_{OH} @ I_{CRD_IO} = –20 μA, V_{I/O} = V_{DD} Output V_{OL} @ I_{CRD_IO} = +1 mA, V_{I/O} = 0 V CRD_I/O Rise Time @ C_{out} = 30 pF CRD_I/O Fall Time @ C_{out} = 30 pF</p> <p>CRD_V_{CC} = +1.8 V Output V_{OH} @ I_{CRD_IO} = –20 μA, V_{I/O} = V_{DD} Output V_{OL} @ I_{CRD_IO} = +1 mA, V_{I/O} = 0 V CRD_I/O Rise Time @ C_{out} = 30 pF CRD_I/O Fall Time @ C_{out} = 30 pF</p> <p>Short-Circuit Current, V_{I/O} = 0 V</p>	<p>0.8 * CRD_V_{CC} 0</p> <p>0.8 * CRD_V_{CC} 0</p>		<p>CRD_V_{CC} 0.4 0.8 0.8</p> <p>CRD_V_{CC} 0.3 0.8 0.8</p> <p>15</p>	<p>V V μs μs</p> <p>V V μs μs</p> <p>mA</p>
8	R _{pu_CRD_I/O}	Card I/O Pullup Resistor	10	14	18	kΩ

NOTE: Device will meet the specifications after thermal equilibrium has been established when mounted in a test socket or printed circuit board with maintained transverse airflow greater than 500 lfm. Electrical parameters are guaranteed only over the declared operating temperature range. Functional operation of the device exceeding these conditions is not implied. Device specification limit values are applied individually under normal operating conditions and not valid simultaneously.

3. All the dynamic specifications (AC specifications) are guaranteed by design over the operating temperature range.

TYPICAL CHARACTERISTICS

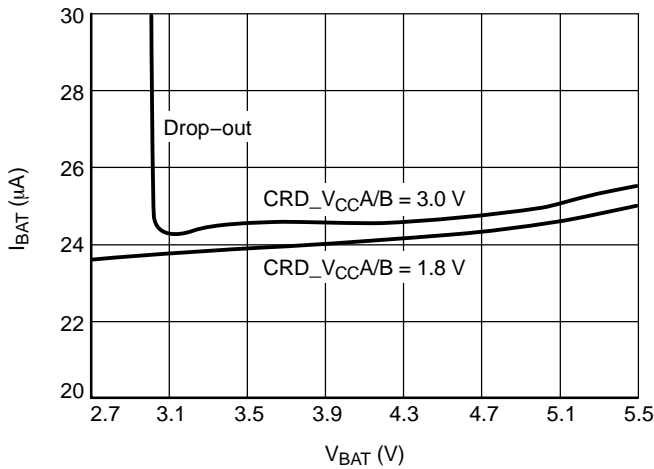

Figure 4. I_{BAT} Operating Current vs. V_{BAT} ,
 $T_A = 25^\circ\text{C}$, $I_{CC} = 0\text{ mA}$

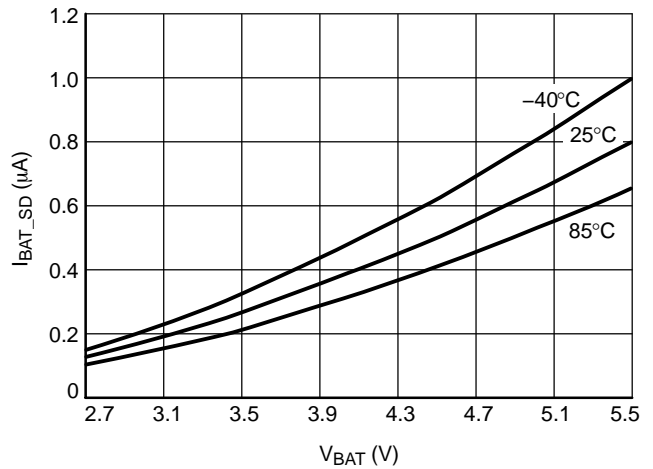

Figure 5. I_{BAT} Shutdown Current vs. V_{BAT}

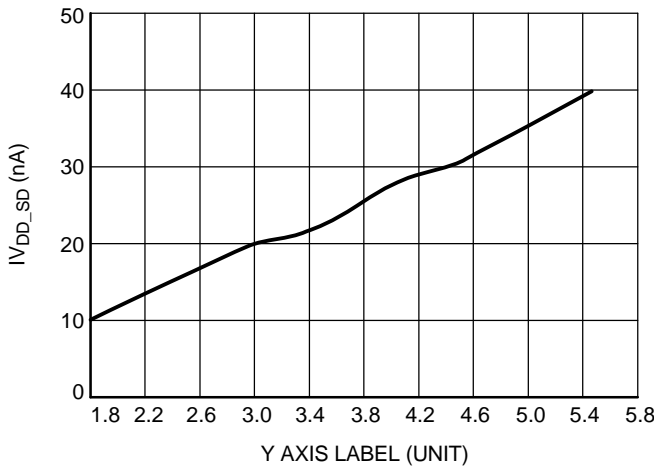

Figure 6. I_{VDD} Shutdown Current vs. V_{DD} ,
 $T_A = 25^\circ\text{C}$, $V_{BAT} = 5.5\text{ V}$

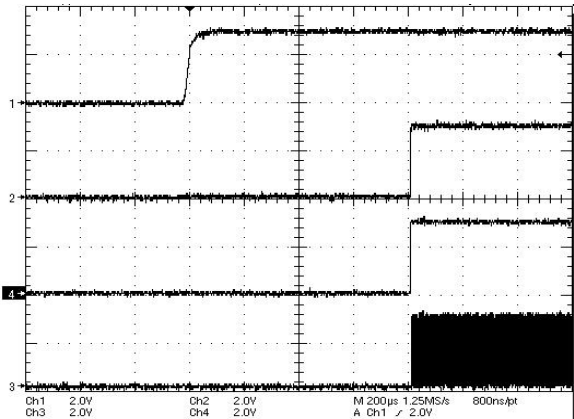

Figure 7. Activation Sequence, Ch1 : CRD_VCC,
 Ch2 : CRD_IO, Ch4 : CRD_RST, Ch3 : CRD_CLK

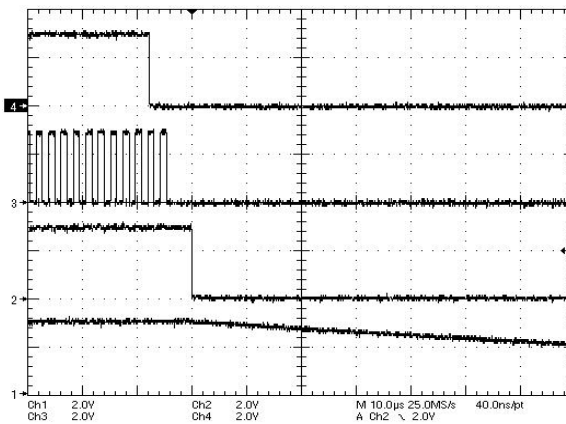

Figure 8. Automatic Deactivation
 Ch4: CRD_RST, Ch3: CRD_CLK, Ch2: CRD_IO,
 Ch1: CRD_VCC

APPLICATION INFORMATION

The NCN4557 is a dual LDO-based DC/DC converter and level shifter able to handle independently 2 smart card interfaces. When one of these interfaces is operating the other one is not active and conversely. Class B (3.0 V) and C (1.8 V) cards can be used.

The Card and the CRD_VCC power supply are selected using the pins SEL0, SEL1 and ENABLE according to Table 1.

Table 1. CARD AND CRD_VCC SELECTION

ENABLE	SEL1	SEL0	Card# / CRD_VCC
1	0	0	Card A / 1.8 V
1	0	1	Card A / 3.0 V
1	1	0	Card B / 1.8 V
1	1	1	Card B / 3.0 V
0	X	X	A & B Disabled

Card Supply Converter

The built-in NCN4557 DC/DC converters are Low Drop-Out Voltage Regulators capable to supply a current in excess of 50 mA under 1.8 V or 3.0 V. These voltages are selected according to Table 1. Using the Boolean input ENABLE pin the NCN4557 device can be disabled setting the circuit in a shutdown mode for which the power consumption features values typically in the range of a few tens of nA. Figure 9 shows a simplified view of the NCN4557 voltage regulator. The CRD_VCC output is internally current limited and protected against short circuits. The short-circuit current I_{VCC} varies with V_{BAT} typically in the range of 30 mA to 60 mA.

In order to guarantee a stable and satisfying operating of the LDO the CRD_VCC output will be connected to a 1.0 μ F bypass ceramic capacitor to the ground. At the input, V_{BAT} will be bypassed to the ground with a 0.1 μ F ceramic capacitor.

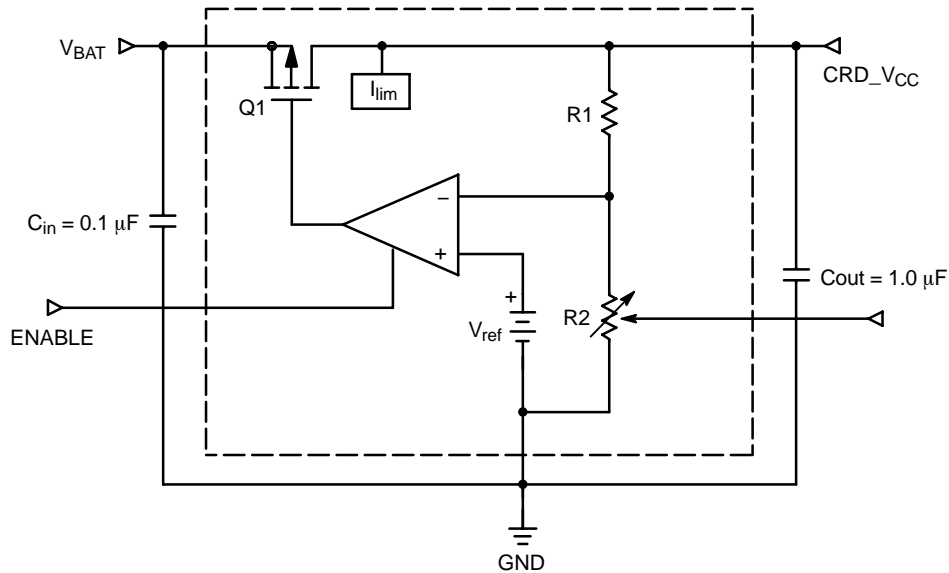

Figure 9. Simplified Block Diagram of the LDO Voltage Regulator

Level Shifters

The level shifters accommodate the voltage difference that might exist between the microcontroller and the smart card. The RESET and CLOCK level shifters are mono-directional and feature both the same architecture.

The bidirectional I/O line provides a way to automatically adapt the voltage difference between the

controller and the card in both directions. In addition with the pull-up resistor, a dynamic pullup circuit (Figure 10, Q1 and Q2) provides a fast charge of the stray capacitance, yielding a rise time fully within the ISO7816, EMV and GSM specifications.

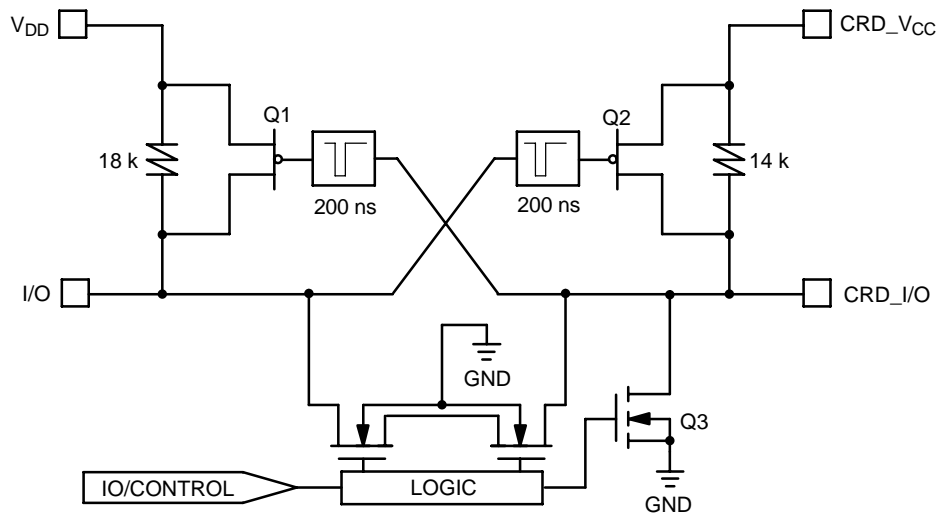

Figure 10. Basic I/O line Interface

The typical waveform provided in Figure 11 shows how the accelerator operates. During the first 200 ns (typical), the slope of the rise time is solely a function of the pullup resistor associated with the stray capacitance. During this period, the PMOS devices are not activated since the input voltage is below their V_{gs} threshold. When the input slope crosses the V_{gsth} , the opposite one shot is activated, providing a low impedance to charge the capacitance, thus increasing the rise time as depicted in Figure 11. The same mechanism applies for the opposite side of the line to make sure the system is optimum.

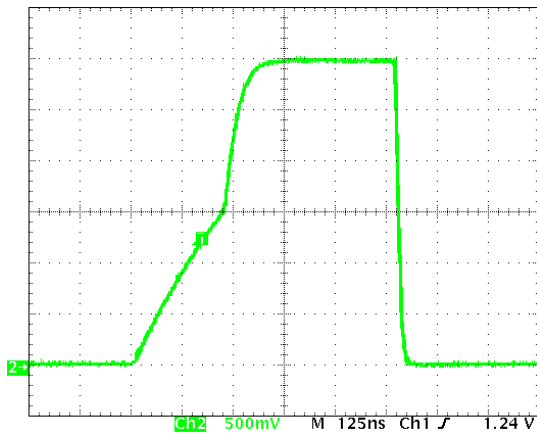

Figure 11. CRD_IO Typical Rise and Fall Times with Stray Capacitance > 30 pF (33 pF capacitor connected on the board)

Powerup Sequence

The powerup sequence makes sure all the card-related signals are LOW during the CRD_VCC positive going slope. The Powerup sequence is activated by setting the ENABLE Boolean signal HIGH. CRD_RST, CRD_CLK and CRD_I/O are maintained LOW during the activation stage until CRD_VCC reaches its nominal value (1.8 V or

3.0 V). Figure 7 shows the typical NCN4557 activation sequence.

About 800 μs after CRD_VCC has reached its nominal voltage value, CRD_IO and CRD_RST are released.

CRD_CLK is enabled during the rising slope of the second clock cycle after CRD_IO and CRD_RST are enabled.

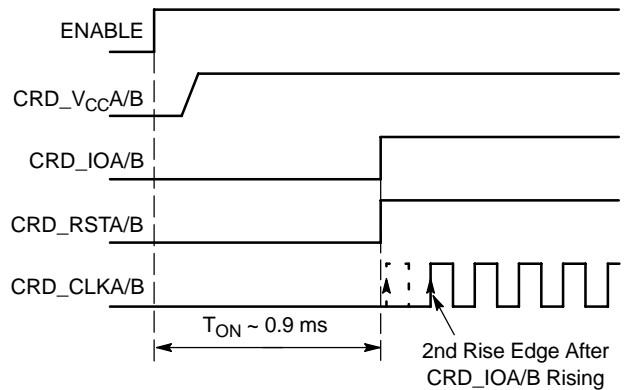

Figure 12. NCN4557 Power-Up

In all cases the application software is responsible for the smart card signal sequence (contact activation sequence, cold reset and warm reset sequences).

Powerdown Sequence

The NCN4557 provides a powerdown sequence which is activated by setting the ENABLE Boolean signal LOW. The communication I/O session is terminated immediately according to the ISO7816 and EMV specifications as depicted in Figures 8 and 13.

ISO7816 Sequence:

- CRD_RST is forced to LOW
- CRD_CLK is forced to LOW 2 clock cycles after ENABLE is set LOW unless CRD_CLK is already in

this state or 8 μ s after the ENABLE pin is set LOW in the other cases.

- CRD_I/O is forced to LOW about 8 μ s after the ENABLE pin is set LOW.
- Then CRD_V_{CC} Supply Shuts Off

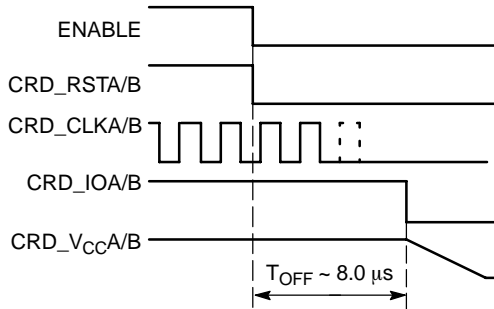

Figure 13. NCN4557 Power Down Sequence

Input Schmitt Triggers

All the logic input pins (excepted I/O and CRD_I/O, Figure 3) have built-in Schmitt trigger circuits to prevent the NCN4557 against uncontrolled operation. The typical dynamic characteristics of the related pins are depicted in Figure 14.

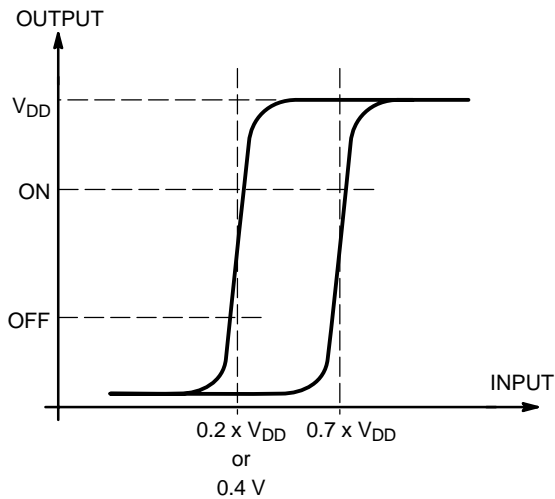

Figure 14. Typical Schmitt Trigger Characteristics

ORDERING INFORMATION

Device	Package	Shipping†
NCN4557MTG	QFN-16 (Pb-Free)	123 Units / Rail
NCN4557MTR2G	QFN-16 (Pb-Free)	3000 / Tape & Reel

†For information on tape and reel specifications, including part orientation and tape sizes, please refer to our Tape and Reel Packaging Specifications Brochure, BRD8011/D.

Shutdown Operating

In order to save power or for other purpose required by the application it is possible to put the NCN4557 in a shutdown mode by setting LOW the pin ENABLE. On the other hand the device enters automatically in a shutdown mode when V_{DD} becomes lower than 1.0 V typically.

ESD Protection

The NCN4557 CRD interface features an Human Body Model ESD voltage protection in excess of 8 kV for all the CRD pins (CRD_IOA & B, CRD_CLKA & B, CRD_RSTA & B, CRD_V_{CCA} & B and GND). All the other pins (microcontroller side) sustain at least 2 kV. These values are guaranteed for the device in its full integrity without considering the external capacitors added to the circuit for a proper operating. Consequently in the operating conditions it is able to sustain much more than 8 kV on its CRD pins making it perfectly protected against electrostatic discharge well over the Human Body Model ESD voltages required by the ISO7816 standard (4 kV).

Printed Circuit Board Layout

Careful layout routing will be applied to achieve a good and efficient operating of the device in its mobile or portable environment and fully exploit its performance.

The bypass capacitors have to be connected as close as possible to the device pins (CRD_V_{CCA} and B, V_{DD} or V_{BAT}) in order to reduce as much as possible parasitic behaviors (ripple and noise). It is recommended to use ceramic capacitors.

The exposed pad of the QFN-16 package will be connected to the ground. A relatively large ground plane is recommended.

NCN4557

PACKAGE DIMENSIONS

QFN16 3*3*0.75 MM, 0.5 P
CASE 488AK-01
ISSUE O

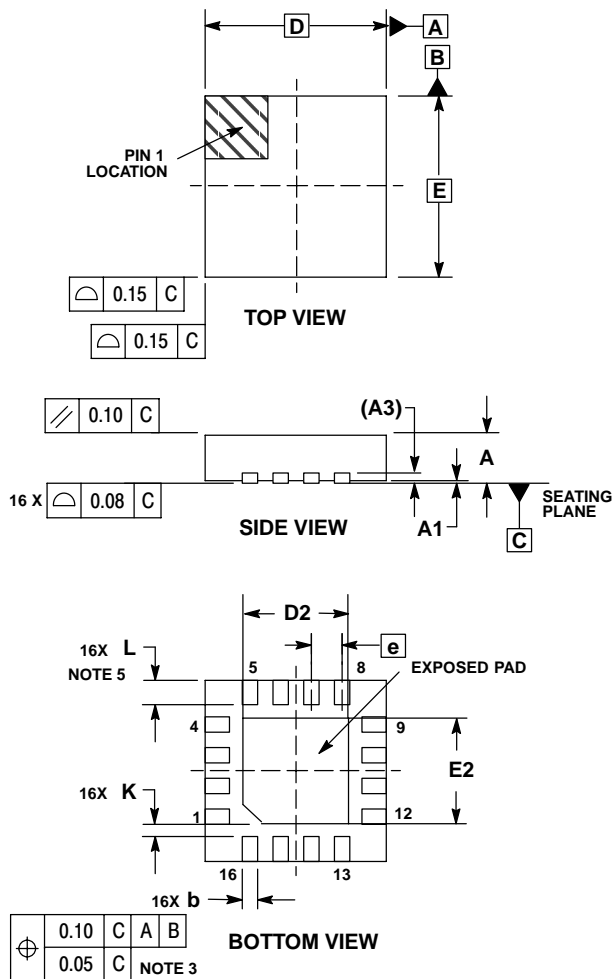

NOTES:

1. DIMENSIONING AND TOLERANCING PER ASME Y14.5M, 1994.
2. CONTROLLING DIMENSION: MILLIMETERS.
3. DIMENSION b APPLIES TO PLATED TERMINAL AND IS MEASURED BETWEEN 0.25 AND 0.30 MM FROM TERMINAL.
4. COPLANARITY APPLIES TO THE EXPOSED PAD AS WELL AS THE TERMINALS.
5. L_{max} CONDITION CAN NOT VIOLATE 0.2 MM SPACING BETWEEN LEAD TIP AND FLAG.

MILLIMETERS		
DIM	MIN	MAX
A	0.70	0.80
A1	0.00	0.05
A3	0.20 REF	
b	0.18	0.30
D	3.00 BSC	
D2	1.65	1.85
E	3.00 BSC	
E2	1.65	1.85
e	0.50 BSC	
K	0.20	---
L	0.30	0.50

ON Semiconductor and are registered trademarks of Semiconductor Components Industries, LLC (SCILLC). SCILLC reserves the right to make changes without further notice to any products herein. SCILLC makes no warranty, representation or guarantee regarding the suitability of its products for any particular purpose, nor does SCILLC assume any liability arising out of the application or use of any product or circuit, and specifically disclaims any and all liability, including without limitation special, consequential or incidental damages. "Typical" parameters which may be provided in SCILLC data sheets and/or specifications can and do vary in different applications and actual performance may vary over time. All operating parameters, including "Typicals" must be validated for each customer application by customer's technical experts. SCILLC does not convey any license under its patent rights nor the rights of others. SCILLC products are not designed, intended, or authorized for use as components in systems intended for surgical implant into the body, or other applications intended to support or sustain life, or for any other application in which the failure of the SCILLC product could create a situation where personal injury or death may occur. Should Buyer purchase or use SCILLC products for any such unintended or unauthorized application, Buyer shall indemnify and hold SCILLC and its officers, employees, subsidiaries, affiliates, and distributors harmless against all claims, costs, damages, and expenses, and reasonable attorney fees arising out of, directly or indirectly, any claim of personal injury or death associated with such unintended or unauthorized use, even if such claim alleges that SCILLC was negligent regarding the design or manufacture of the part. SCILLC is an Equal Opportunity/Affirmative Action Employer. This literature is subject to all applicable copyright laws and is not for resale in any manner.

PUBLICATION ORDERING INFORMATION

LITERATURE FULFILLMENT:
Literature Distribution Center for ON Semiconductor
P.O. Box 5163, Denver, Colorado 80217 USA
Phone: 303-675-2175 or 800-344-3860 Toll Free USA/Canada
Fax: 303-675-2176 or 800-344-3867 Toll Free USA/Canada
Email: orderlit@onsemi.com

N. American Technical Support: 800-282-9855 Toll Free
USA/Canada
Europe, Middle East and Africa Technical Support:
Phone: 421 33 790 2910
Japan Customer Focus Center
Phone: 81-3-5773-3850

ON Semiconductor Website: www.onsemi.com
Order Literature: <http://www.onsemi.com/orderlit>

For additional information, please contact your local Sales Representative

Looking for pricing, stock, or lifecycle information?

Click below to explore more details on WIN SOURCE:

 [View NCN4557MTG on WIN SOURCE](#)

 [ON Semiconductor](#) Information

Optimize Your Supply Chain with WIN SOURCE Solutions

-  Global Sourcing Solution
-  Obsolete Management
-  Cost Control Management
-  Shortage Management
-  Alternative Solution
-  Excess Inventory Management