



**THE DATASHEET OF
DF11-24DS-2C**



TL431LI-Q1 / TL432LI-Q1 Programmable Shunt Regulator With Optimized Reference Current

1 Features

- Qualified for automotive applications
- AEC-Q100 qualified with the following results:
 - Device temperature grade 1: -40°C to $+125^{\circ}\text{C}$ ambient operating temperature
 - Device temperature grade 0: -40°C to $+150^{\circ}\text{C}$ ambient operating temperature
- Reference voltage tolerance at 25°C
 - 0.5% (B grade)
 - 1% (A grade)
- Minimum typical output voltage: 2.495 V
- Adjustable output voltage: V_{ref} to 36 V
- 27 mV maximum temperature drift for grade 1
- 34 mV maximum temperature drift for grade 0
- 0.3- Ω typical output impedance
- Sink-current capability
 - $I_{\text{min}} = 0.6 \text{ mA}$ (max)
 - $I_{\text{KA}} = 15 \text{ mA}$ (max)
- Reference input current I_{REF} : 0.4 μA (max)
- Deviation of reference input current over temperature, $I_{\text{I(dev)}}$: 0.3 μA (max)

2 Applications

- [Inverter and motor control](#)
- [DC/DC converter](#)
- [LED lighting](#)
- [On-board charger \(OBC\)](#)
- [Infotainment and cluster](#)
- [Engine management actuator](#)
- [Transmission](#)
- [Power steering](#)
- [Powertrain exhaust sensor](#)
- [Alternator starter](#)

3 Description

The TL431LI-Q1 is a three-terminal adjustable shunt regulator, with specified thermal stability over applicable automotive, commercial, and military temperature ranges. The output voltage can be set to any value between V_{ref} (approximately 2.495 V) and 36 V with two external resistors. The device has a typical output impedance of 0.3 Ω . Its active output circuitry provides a very sharp turn-on characteristic, making it an excellent replacement for Zener diodes in many applications, such as onboard regulation, adjustable power supplies, and switching power supplies. This device is a pin-to-pin alternative to the industry standard TL431-Q1 with optimized I_{ref} and I_{Idev} performance. The lower I_{ref} and I_{Idev} values of the TL431LI-Q1 enable designers to achieve higher system accuracy and lower leakage current. The TL432LI-Q1 has exactly the same functionality and electrical specifications as the TL431LI-Q1, but has a different pinout for the DBZ package.

The TL431LI-Q1 is offered in two grades, with initial tolerances (at 25°C) of 0.5% and 1%, for the B and A grade, respectively. The TL431LI-Q1 is also available in two temperature grades: grade 1 (denoted by a 'Q' in the part number), and grade 0 (denoted by a 'E' in the part number), which represent maximum ambient operating temperatures of 125°C and 150°C respectively. The TL43xLI-Q1 is characterized for operation from -40°C to 125°C for grade 1, and -40°C to 150°C for grade 0, and its low output drift versus temperature ensures good stability over the entire temperature range.

Device Information⁽¹⁾

PART NUMBER	PACKAGE (PIN)	BODY SIZE (NOM)
TL43xLI-Q1	SOT-23 (3)	2.90 mm x 1.30 mm

(1) For all available packages, see the orderable addendum at the end of the data sheet.

Simplified Schematic

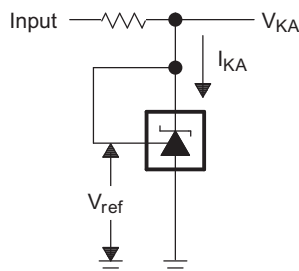

Table of Contents

1 Features	1	9.4 Device Functional Modes.....	12
2 Applications	1	10 Applications and Implementation	13
3 Description	1	10.1 Application Information.....	13
4 Revision History	2	10.2 Typical Applications	13
5 Device Comparison Table	3	10.3 System Examples	22
6 Pin Configuration and Functions	3	11 Power Supply Recommendations	25
7 Specifications	4	12 Layout	25
7.1 Absolute Maximum Ratings	4	12.1 Layout Guidelines	25
7.2 ESD Ratings.....	4	12.2 Layout Example	25
7.3 Recommended Operating Conditions.....	4	13 Device and Documentation Support	26
7.4 Thermal Information	4	13.1 Device Support.....	26
7.5 Electrical Characteristics.....	5	13.2 Documentation Support	26
7.6 Typical Characteristics.....	6	13.3 Related Links	26
8 Parameter Measurement Information	9	13.4 Receiving Notification of Documentation Updates	26
8.1 Temperature Coefficient.....	9	13.5 Support Resources	26
8.2 Dynamic Impedance	10	13.6 Trademarks	27
9 Detailed Description	11	13.7 Electrostatic Discharge Caution.....	27
9.1 Overview	11	13.8 Glossary	27
9.2 Functional Block Diagram	11	14 Mechanical, Packaging, and Orderable	27
9.3 Feature Description.....	12	Information	27

4 Revision History

NOTE: Page numbers for previous revisions may differ from page numbers in the current version.

Changes from Original (May 2019) to Revision A	Page
• Changed device status from Advance Information to Production Data	1

5 Device Comparison Table

DEVICE PINOUT	INITIAL ACCURACY	OPERATING FREE-AIR TEMPERATURE (T _A)
TL431LI-Q1 TL432LI-Q1	A: 1% B: 0.5%	Q: -40°C to 125°C E: -40°C to 150°C

6 Pin Configuration and Functions

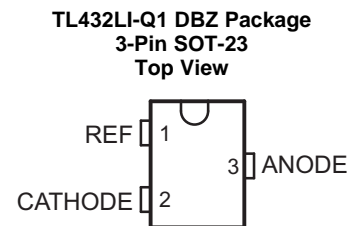
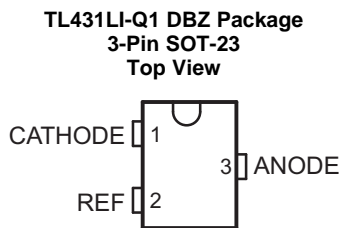

Pin Functions

NAME	PIN NUMBER		TYPE	DESCRIPTION
	TL431LI-Q1	TL432LI-Q1		
	DBZ	DBZ		
ANODE	3	3	O	Common pin, normally connected to ground
CATHODE	1	2	I/O	Shunt current/Voltage input
REF	2	1	I	Threshold relative to common anode

7 Specifications

7.1 Absolute Maximum Ratings

over operating free-air temperature range (unless otherwise noted)⁽¹⁾

		MIN	MAX	UNIT
V _{KA}	Cathode Voltage ⁽²⁾		37	V
I _{KA}	Continuous Cathode Current Range	-10	18	mA
I _{I(ref)}	Reference Input Current	-5	10	mA
T _J	Operating Junction Temperature Range	-40	150	C
T _{stg}	Storage Temperature Range	-65	150	C

- (1) Stresses beyond those listed under *Absolute Maximum Ratings* may cause permanent damage to the device. These are stress ratings only, which do not imply functional operation of the device at these or any other conditions beyond those indicated under *Recommended Operating Conditions*. Exposure to absolute-maximum-rated conditions for extended periods may affect device reliability.
- (2) All voltage values are with respect to ANODE, unless otherwise noted.

7.2 ESD Ratings

		VALUE	UNIT
V _(ESD)	Electrostatic discharge	Human body model (HBM), per AEC Q100-002 ⁽¹⁾	±4000
		Charged-device model (CDM), per AEC Q100-011	±1000

- (1) AEC Q100-002 indicates that HBM stressing shall be in accordance with the ANSI/ESDA/JEDEC JS-001 specification

7.3 Recommended Operating Conditions

		MIN	MAX	UNIT	
V _{KA}	Cathode Voltage	V _{REF}	36	V	
I _{KA}	Continuous Cathode Current Range	0.6	15	mA	
T _A	Operating Free-Air Temperature ⁽¹⁾	TL43xLIxQ	-40	125	C
		TL43xLIxE	-40	150	C

- (1) Maximum power dissipation is a function of T_{J(max)}, θ_{JA}, and T_A. The maximum allowable power dissipation at any allowable ambient temperature is P_D = (T_{J(max)} - T_A)/θ_{JA}. Operating at the absolute maximum T_J can affect reliability. Please see the [Semiconductor and IC Package Thermal Metrics Application Report](#) for more information.

7.4 Thermal Information

THERMAL METRIC ⁽¹⁾		TL43xLI	UNIT
		DBZ	
		3 PINS	
R _{θJA}	Junction-to-ambient thermal resistance	371.7	C/W
R _{θJC(top)}	Junction-to-case (top) thermal resistance	145.9	C/W
R _{θJB}	Junction-to-board thermal resistance	104.7	C/W
ψ _{JT}	Junction-to-top characterization resistance	23.9	C/W
ψ _{JB}	Junction-to-board characterization resistance	102.9	C/W

- (1) For more information about traditional and new thermal metrics, see the [Semiconductor and IC Package Thermal Metrics Application Report](#).

7.5 Electrical Characteristics

over recommended operating conditions, $T_A = 25^\circ\text{C}$ (unless otherwise noted)

PARAMETER		TEST CIRCUIT	TEST CONDITIONS	MIN	TYP	MAX	UNIT	
V_{ref}	Reference Voltage	See Figure 14	$V_{\text{KA}} = V_{\text{ref}}, I_{\text{KA}} = 1 \text{ mA}$	TL43xLlAx devices	2470	2495	2520	mV
				TL43xLlBx devices	2483	2495	2507	mV
$V_{\text{I(dev)}}$	Deviation of reference input voltage over full temperature range ⁽¹⁾	See Figure 14	$V_{\text{KA}} = V_{\text{ref}}, I_{\text{KA}} = 1 \text{ mA}$	TL43xLlQ devices	10	27	mV	
				TL43xLlEx devices	14	34	mV	
$\frac{\Delta V_{\text{ref}}}{\Delta V_{\text{KA}}}$	Ratio of change in reference voltage to the change in cathode voltage	See Figure 15	$I_{\text{KA}} = 1 \text{ mA}$	$\Delta V_{\text{KA}} = 10 \text{ V} - V_{\text{ref}}$	-1.4	-2.7	mV/V	
				$\Delta V_{\text{KA}} = 36 \text{ V} - 10 \text{ V}$	-1	-2	mV/V	
I_{ref}	Reference Input Current	See Figure 15	$I_{\text{KA}} = 1 \text{ mA}, R1 = 10\text{k}\Omega, R2 = \infty$		0.2	0.4	μA	
$I_{\text{I(dev)}}$	Deviation of reference input current over full temperature range ⁽¹⁾	See Figure 15	$I_{\text{KA}} = 1 \text{ mA}, R1 = 10\text{k}\Omega, R2 = \infty$		0.1	0.3	μA	
I_{min}	Minimum cathode current for regulation	See Figure 14	$V_{\text{KA}} = V_{\text{ref}}$			0.6	mA	
I_{off}	Off-state cathode current	See Figure 16	$V_{\text{KA}} = 36 \text{ V}, V_{\text{ref}} = 0$		0.1	1	μA	
$ Z_{\text{KA}} $	Dynamic Impedance ⁽²⁾	See Figure 14	$V_{\text{KA}} = V_{\text{ref}}, I_{\text{KA}} = 1 \text{ mA to } 15 \text{ mA}$		0.3	0.75	Ω	

- (1) The deviation parameters $V_{\text{I(dev)}}$ and $I_{\text{I(dev)}}$ are defined as the differences between the maximum and minimum values obtained over the rated temperature range. For more details on $V_{\text{I(dev)}}$ and how it relates to the average temperature coefficient, see the [Temperature Coefficient](#) section.
- (2) The dynamic impedance is defined by $|Z_{\text{KA}}| = \Delta V_{\text{KA}} / \Delta I_{\text{KA}}$. For more details on $|Z_{\text{KA}}|$ and how it relates to V_{KA} , see the [Temperature Coefficient](#) section.

7.6 Typical Characteristics

Data at high and low temperatures are applicable only within the recommended operating free-air temperature ranges of the various devices.

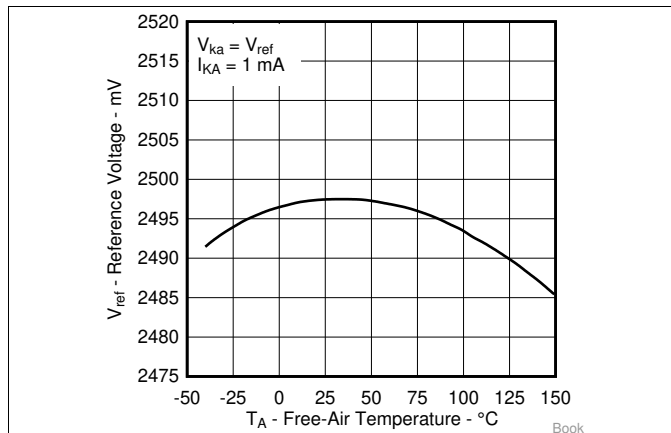

Figure 1. Reference Voltage versus Free-Air Temperature

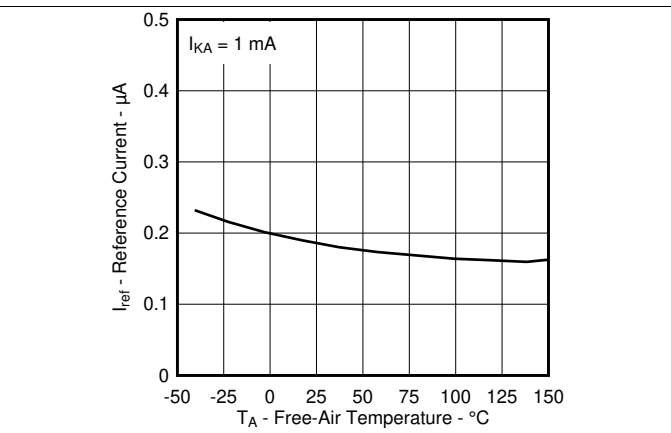

Figure 2. Reference Current versus Free-Air Temperature

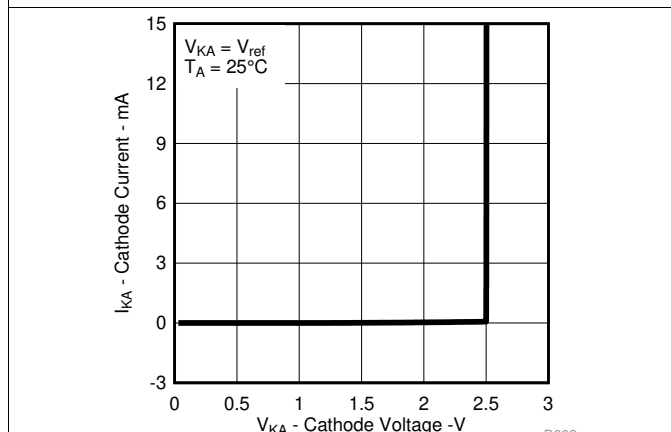

Figure 3. Cathode Current versus Cathode Voltage

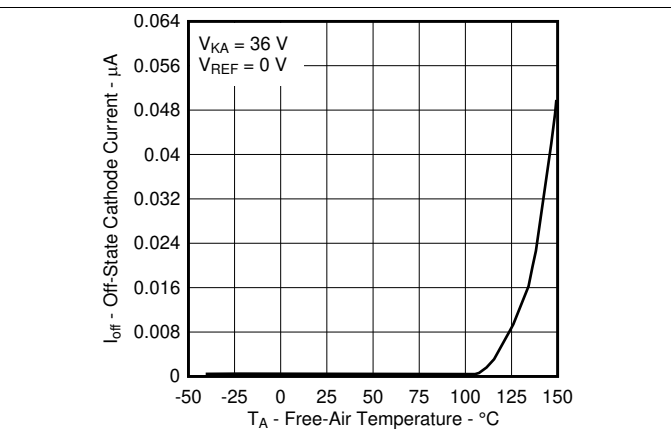

Figure 4. Off-State Cathode Current versus Free-Air Temperature

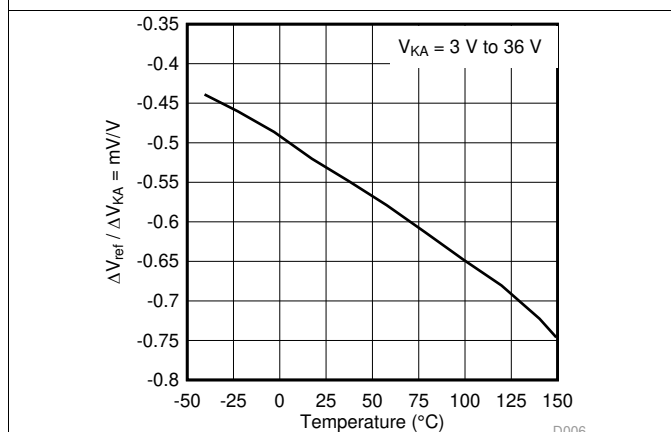

Figure 5. Ratio of Delta Reference Voltage to Delta Cathode Voltage versus Free-Air Temperature

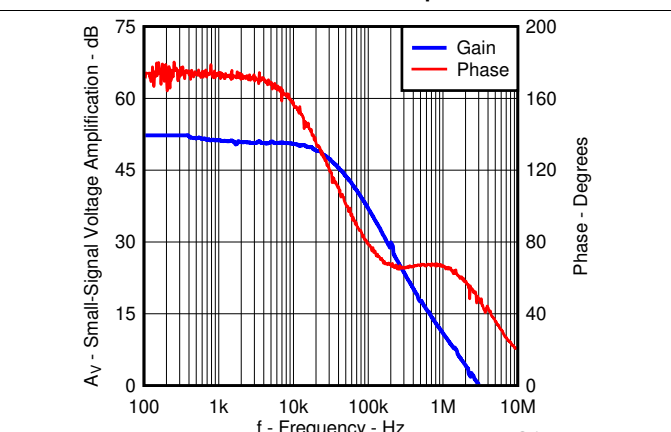
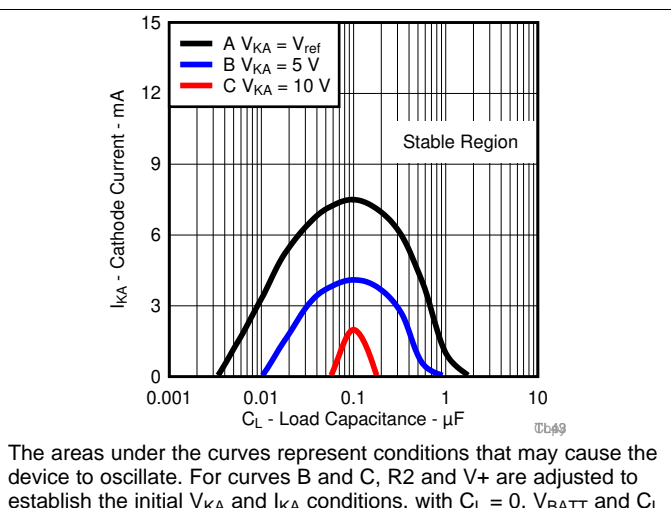
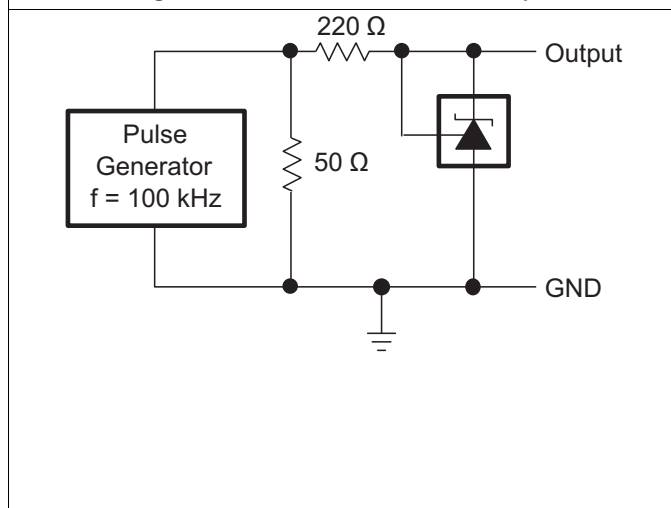
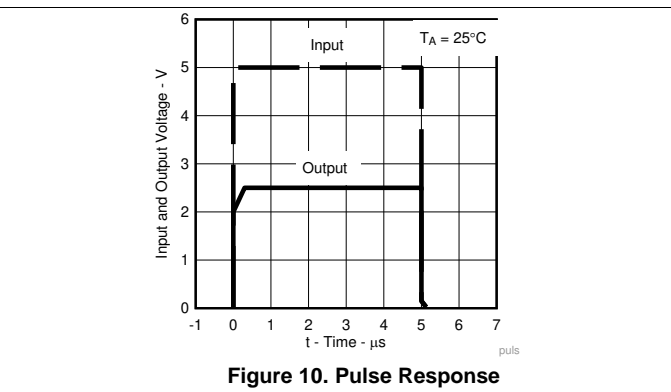
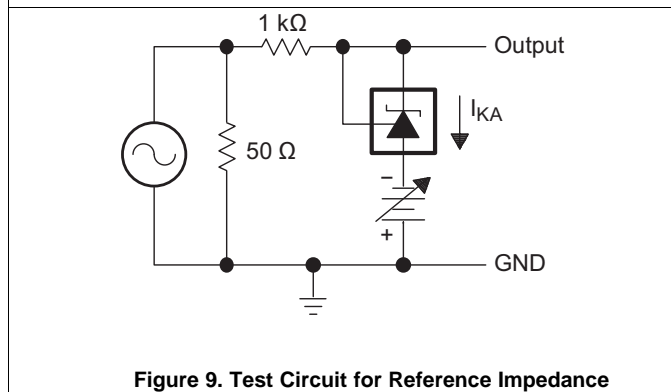
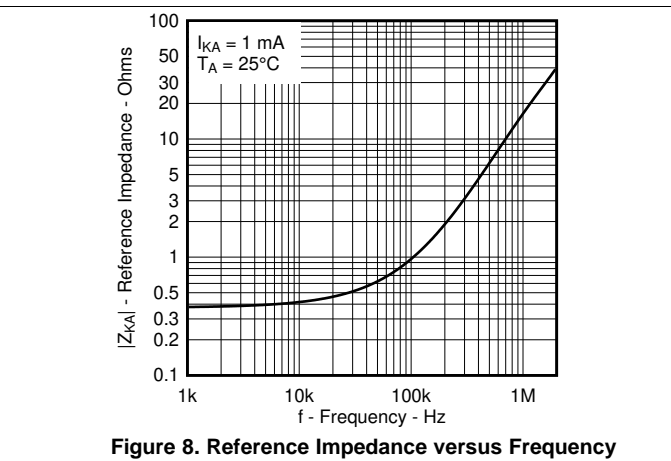
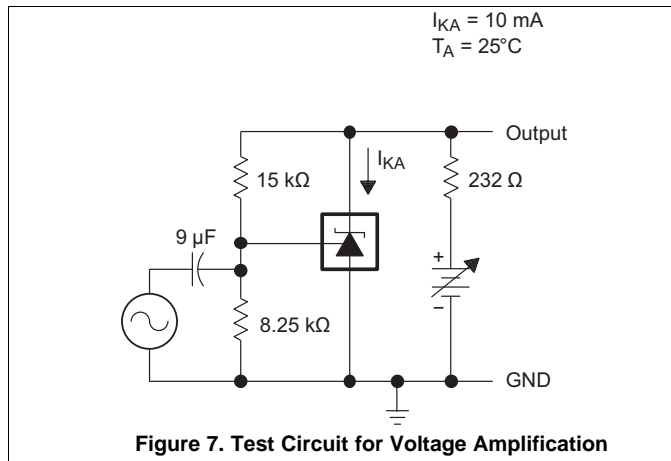

Figure 6. Small-Signal Voltage Amplification versus Frequency

Typical Characteristics (continued)



The areas under the curves represent conditions that may cause the device to oscillate. For curves B and C, R2 and V+ are adjusted to establish the initial V_{KA} and I_{KA} conditions, with $C_L = 0$. V_{BATT} and C_L then are adjusted to determine the ranges of stability.

Typical Characteristics (continued)

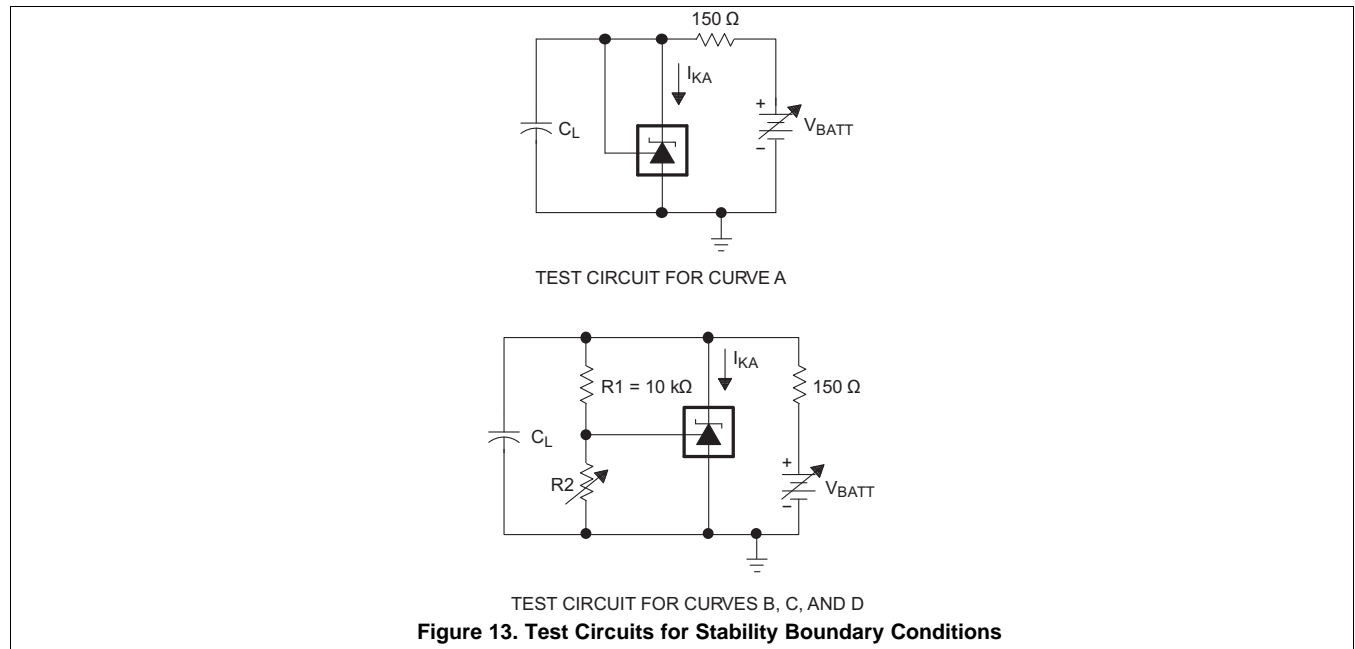

8 Parameter Measurement Information

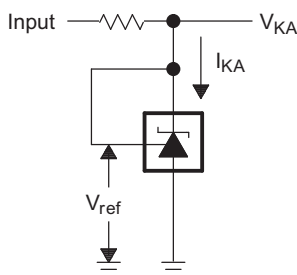

Figure 14. Test Circuit for $V_{KA} = V_{ref}$

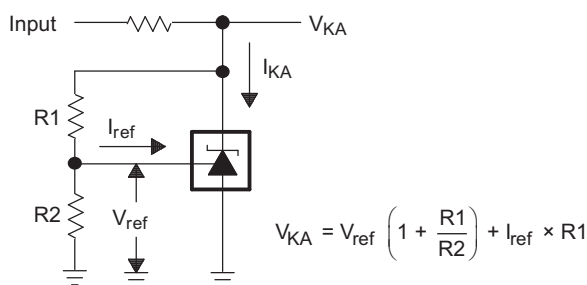

Figure 15. Test Circuit for $V_{KA} > V_{ref}$

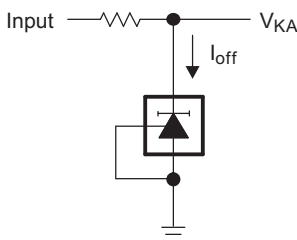

Figure 16. Test Circuit for I_{off}

8.1 Temperature Coefficient

The deviation of the reference voltage, V_{ref} , over the full temperature range is known as $V_{I(dev)}$. The parameter of $V_{I(dev)}$ can be used to find the temperature coefficient of the device. The average full-range temperature coefficient of the reference input voltage, $\alpha_{V_{ref}}$, is defined as:

$$\left| \alpha_{V_{ref}} \right| \left(\frac{\text{ppm}}{^{\circ}\text{C}} \right) = \frac{\left(\frac{V_{I(dev)}}{V_{ref \text{ at } 25^{\circ}\text{C}}} \right) \times 10^6}{\Delta T_A}$$

where:

ΔT_A is the rated operating temperature range of the device.

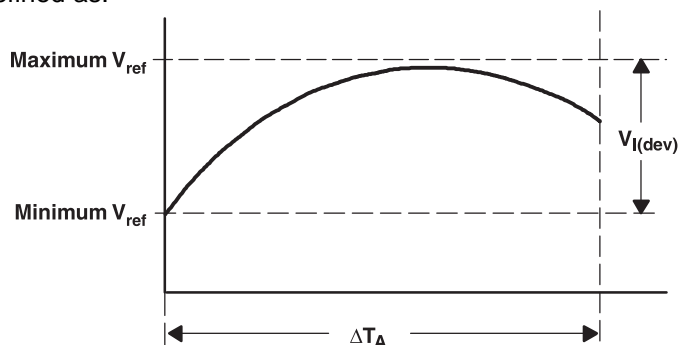

$\alpha_{V_{ref}}$ is positive or negative, depending on whether minimum V_{ref} or maximum V_{ref} , respectively, occurs at the lower temperature. The full-range temperature coefficient is an average and therefore any subsection of the rated operating temperature range can yield a value that is greater or less than the average. For more details on temperature coefficient, refer to the [Voltage Reference Selection Basics White Paper](#).

8.2 Dynamic Impedance

The dynamic impedance is defined as $|Z_{KA}| = \frac{\Delta V_{KA}}{\Delta I_{KA}}$. When the device is operating with two external resistors (see Figure 15), the total dynamic impedance of the circuit is given by $|z'| = \frac{\Delta V}{\Delta I}$, which is approximately equal to $|Z_{KA}| \left(1 + \frac{R1}{R2}\right)$.

The V_{KA} of the TL431LI-Q1 can be affected by the dynamic impedance. The TL431LI-Q1 test current I_{test} for V_{KA} is specified in the *Electrical Characteristics*. Any deviation from I_{test} can cause deviation on the output V_{KA} . Figure 17 shows the effect of the dynamic impedance on the V_{KA} .

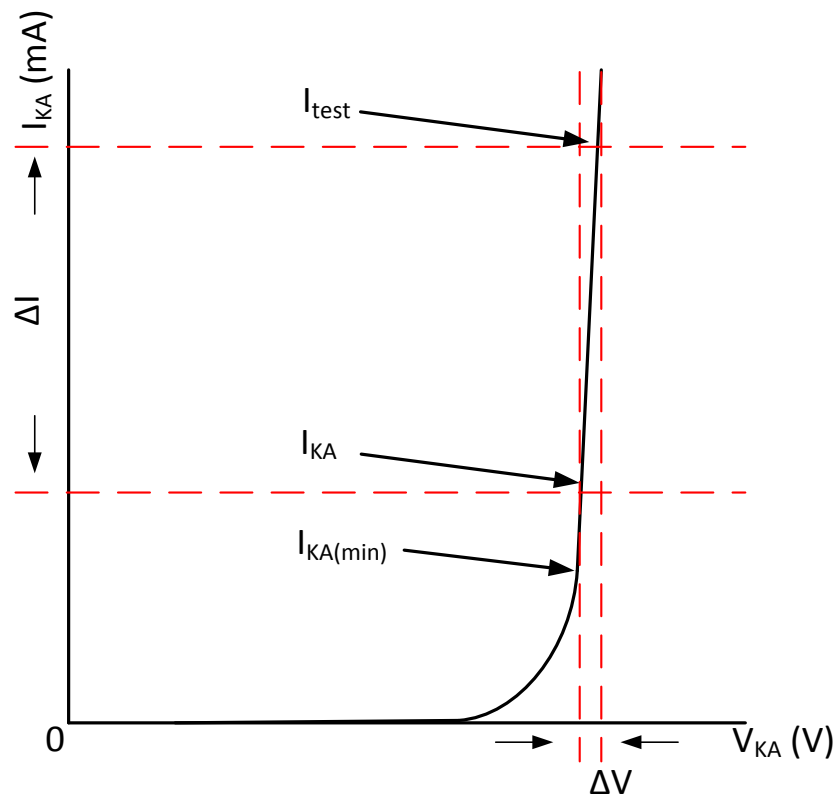

Figure 17. Dynamic Impedance

9 Detailed Description

9.1 Overview

This standard device has proven ubiquity and versatility across a wide range of applications, ranging from power to signal path. This is due to its key components containing an accurate voltage reference and op amp, which are very fundamental analog building blocks. TL43xLI-Q1 is used in conjunction with its key components to behave as a single voltage reference, error amplifier, voltage clamp or comparator with integrated reference.

TL43xLI-Q1 can be operated and adjusted to cathode voltages from 2.495 V to 36 V, making this part optimal for a wide range of end equipments in industrial, auto, telecom and computing. In order for this device to behave as a shunt regulator or error amplifier, $>0.6\text{mA}$ ($I_{\text{min(max)}}$) must be supplied in to the cathode pin. Under this condition, feedback can be applied from the Cathode and Ref pins to create a replica of the internal reference voltage.

Various reference voltage options can be purchased with initial tolerances (at 25°C) of 0.5% (denoted by B), and 1% (denoted by A). TL431LI-Q1 and TL432LI-Q1 are both functionally the same, but have different pinout options.

9.2 Functional Block Diagram

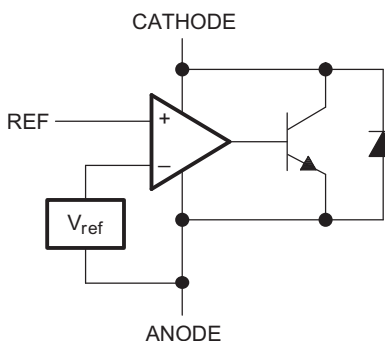

Figure 18. Equivalent Schematic

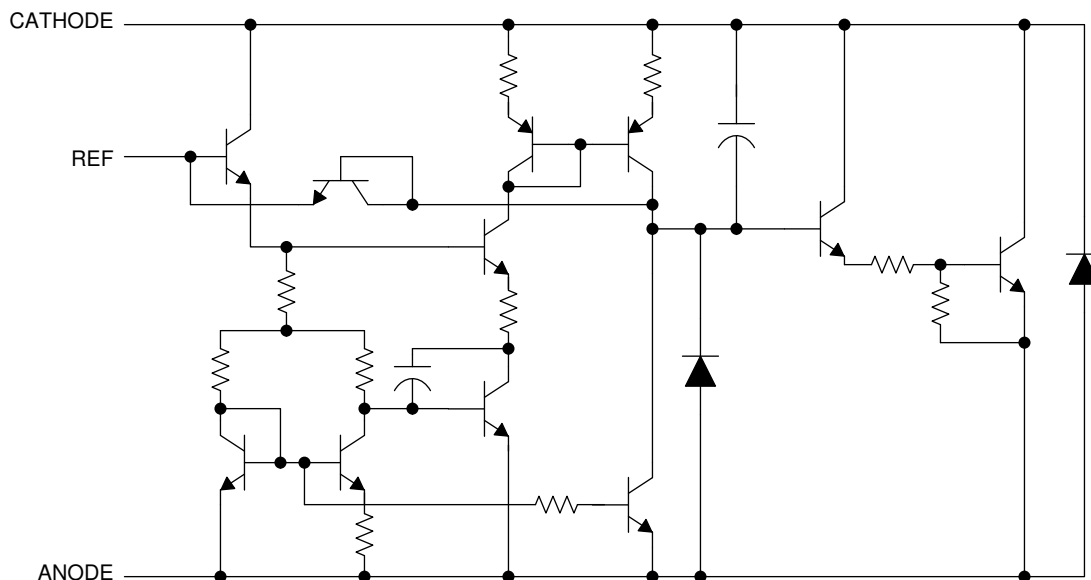

Figure 19. Detailed Schematic

9.3 Feature Description

TL43xLI-Q1 consists of an internal reference and amplifier that outputs a sink current based on the difference between the reference pin and the virtual internal pin. The sink current is produced by the internal Darlington pair, shown in [Figure 19](#). A Darlington pair is used for this device to be able to sink a maximum current of 15 mA.

When operated with enough voltage headroom (≥ 2.495 V) and cathode current (I_{KA}), TL43xLI-Q1 forces the reference pin to 2.495 V. However, the reference pin can not be left floating, as it needs $I_{REF} \geq 0.4$ μ A (see the [Specifications](#)). This is because the reference pin is driven into an npn, which needs base current in order to operate properly.

When feedback is applied from the Cathode and Reference pins, TL43xLI-Q1 behaves as a Zener diode (refer to [Figure 23](#) for a circuit example), regulating to a constant voltage dependent on current being supplied into the cathode. This is due to the internal amplifier and reference entering the proper operating regions. The same amount of current needed in the above feedback situation must be applied to this device in open loop, servo, or error amplifying implementations for it to be in the proper linear region giving TL43xLI-Q1 enough gain.

Unlike many linear regulators, TL43xLI-Q1 is internally compensated to be stable without an output capacitor between the cathode and anode. However, if it is desired to use an output capacitor, [Figure 12](#) can be used as a guide to assist in choosing the correct capacitor to maintain stability.

9.4 Device Functional Modes

9.4.1 Open Loop (Comparator)

When the cathode/output voltage or current of TL43xLI-Q1 is not being fed back to the reference/input pin in any form, this device is operating in open loop. With proper cathode current (I_{KA}) applied to this device, TL43xLI-Q1 has the characteristics shown in [Figure 18](#). With such high gain in this configuration, TL43xLI-Q1 is typically used as a comparator. Since the reference is integrated, TL43xLI-Q1 is the preferred choice when users are trying to monitor a certain level of a single signal. Refer to the [Using the TL431 as a Voltage Comparator Application Report](#) for more details on open loop comparator applications on the TL431LI-Q1.

9.4.2 Closed Loop

When the cathode/output voltage or current of TL43xLI-Q1 is being fed back to the reference/input pin in any form, this device is operating in closed loop. The majority of applications involving TL43xLI-Q1 use it in this manner to regulate a fixed voltage or current. The feedback enables this device to behave as an error amplifier, computing a portion of the output voltage and adjusting it to maintain the desired regulation. This is done by relating the output voltage back to the reference pin in a manner to make it equal to the internal reference voltage, which can be accomplished through resistive or direct feedback.

10 Applications and Implementation

NOTE

Information in the following applications sections is not part of the TI component specification, and TI does not warrant its accuracy or completeness. TI's customers are responsible for determining suitability of components for their purposes. Customers should validate and test their design implementation to confirm system functionality.

10.1 Application Information

As this device has many applications and setups, there are many situations that this data sheet can not characterize in detail. The linked application notes help the designer make the best choices when using this part.

[Designing with the Improved TL431LI Application Note](#) provides a deeper understanding of this accuracy of the device in a flyback optocoupler application. [Setting the Shunt Voltage on an Adjustable Shunt Regulator Application Note](#) assists designers in setting the shunt voltage to achieve optimum accuracy for this device.

10.2 Typical Applications

10.2.1 Comparator With Integrated Reference

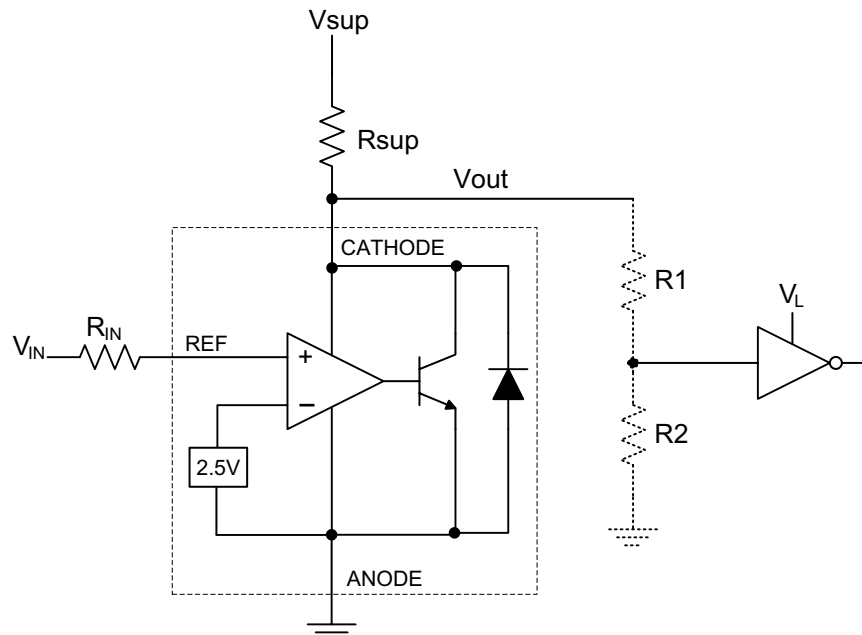

Figure 20. Comparator Application Schematic

Typical Applications (continued)

10.2.2 Design Requirements

For this design example, use the parameters listed in [Table 1](#) as the input parameters.

Table 1. Design Parameters

DESIGN PARAMETER	EXAMPLE VALUE
Input Voltage Range	0 V to 5 V
Input Resistance	10 k Ω
Supply Voltage	24 V
Cathode Current (I_K)	5 mA
Output Voltage Level	$\sim 2\text{ V} - V_{SUP}$
Logic Input Thresholds V_{IH}/V_{IL}	V_L

10.2.3 Detailed Design Procedure

When using TL43xLI-Q1 as a comparator with reference, determine the following:

- Input voltage range
- Reference voltage accuracy
- Output logic input high and low level thresholds
- Current source resistance

10.2.3.1 Basic Operation

In the configuration shown in [Figure 20](#), TL43xLI-Q1 behaves as a comparator, comparing the V_{REF} pin voltage to the internal virtual reference voltage. When provided a proper cathode current (I_K), TL43xLI-Q1 has enough open loop gain to provide a quick response. This can be seen in [Figure 21](#) where the $R_{SUP} = 10\text{ k}\Omega$ ($I_{KA} = 500\ \mu\text{A}$) situation responds much slower than $R_{SUP} = 1\text{ k}\Omega$ ($I_{KA} = 5\text{ mA}$). With the TL43xLI-Q1 max operating current (I_{MIN}) being 1 mA, operation below that can result in low gain, leading to a slow response.

10.2.3.1.1 Overdrive

Slow or inaccurate responses can also occur when the reference pin is not provided enough overdrive voltage. This is the amount of voltage that is higher than the internal virtual reference. The internal virtual reference voltage is within the range of $2.495\text{ V} \pm(0.5\% \text{ or } 1.0\%)$, depending on which version is being used. The more overdrive voltage provided, the faster the TL43xLI-Q1 responds.

For applications where TL43xLI-Q1 is being used as a comparator, it is best to set the trip point to greater than the positive expected error (that is +1.0% for the A version). For fast response, setting the trip point to >10% of the internal V_{REF} suffices.

For minimal voltage drop or difference from V_{in} to the ref pin, TI recommends to use an input resistor <10 k Ω to provide I_{ref} .

10.2.3.2 Output Voltage and Logic Input Level

For TL43xLI-Q1 to properly be used as a comparator, the logic output must be readable by the receiving logic device. This is accomplished by knowing the input high and low level threshold voltage levels, typically denoted by V_{IH} and V_{IL} .

As seen in Figure 21, the output low level voltage of the TL43xLI in open-loop/comparator mode is approximately 2 V, which is typically sufficient for 5 V supplied logic. However, this does not work for 3.3 V and 1.8 V supplied logic. To accommodate this, a resistive divider can be tied to the output to attenuate the output voltage to a voltage legible to the receiving low voltage logic device.

The output high voltage of the TL43xLI is equal to V_{SUP} due to TL43xLI-Q1 being open-collector. If V_{SUP} is much higher than the maximum input voltage tolerance of the maximum logic, the output must be attenuated to accommodate the reliability of the outgoing logic.

When using a resistive divider on the output, make sure the sum of the resistive divider (R_1 and R_2 in Figure 20) is much greater than R_{SUP} to not interfere with the ability of the TL43xLI to pull close to V_{SUP} when turning off.

10.2.3.2.1 Input Resistance

TL43xLI-Q1 requires an input resistance in this application to source the reference current (I_{REF}) needed from this device to be in the proper operating regions while turning on. The actual voltage seen at the ref pin is $V_{REF} = V_{IN} - I_{REF}R_{IN}$. Because I_{REF} can be as high as 0.4 μA , it is recommended to use a resistance small enough that mitigates the error that I_{REF} creates from V_{IN} .

10.2.4 Application Curves

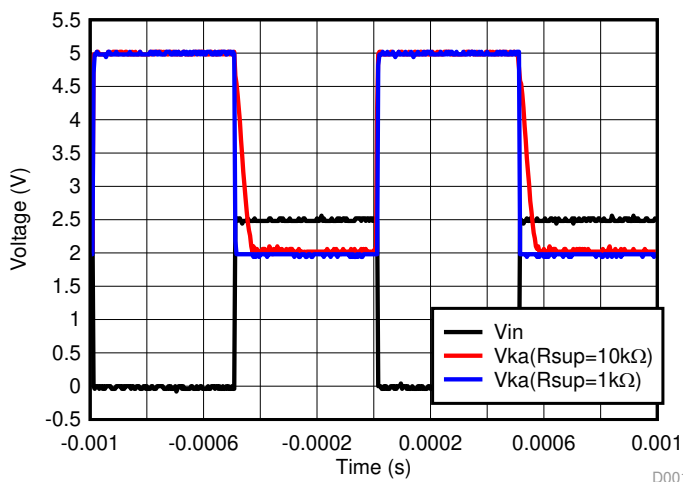

Figure 21. Output Response With Various Cathode Currents

10.2.5 Precision LED Lighting Current Sink Regulator

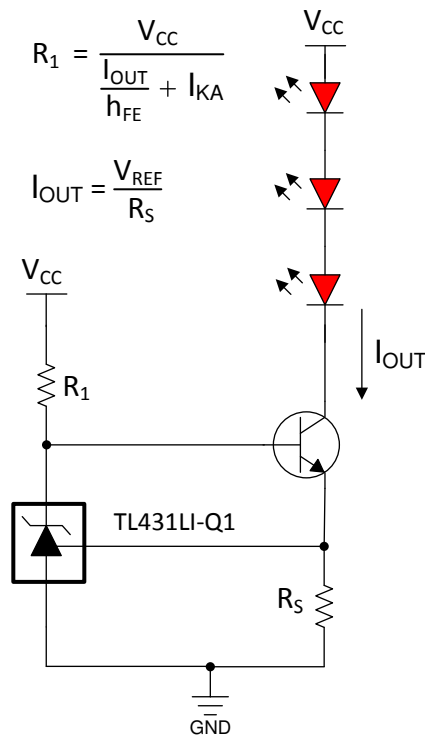

Figure 22. LED Lighting Current Sink Regulator

10.2.5.1 Design Requirements

For this design example, use the parameters listed in Table 1 as the input parameters.

Table 2. Design Parameters

DESIGN PARAMETER	EXAMPLE VALUE
Supply Voltage ($V_{I(BATT)}$)	5 V
Sink Current (I_O)	100mA
Cathode Current (I_K)	5 mA

10.2.5.2 Detailed Design Procedure

When using the TL43xLI-Q1 as a constant current sink, determine the following:

- Output current range
- Output current accuracy
- Power consumption for TL43xLI-Q1

10.2.5.2.1 Basic Operation

In the configuration shown, TL43xLI-Q1 acts as a control component within a feedback loop of the constant current sink. Working with an external passing component such as a BJT, TL43xLI-Q1 provides precision current sink with accuracy set by itself and the sense resistor R_S . The LEDs are lit based on the desired current sink and regulated for accurate brightness and color.

10.2.5.2.1.1 Output Current Range and Accuracy

The output current range of the circuit is determined by the equation shown in the configuration. Keep in mind that the V_{REF} equals to 2.495 V. When choosing the sense resistor R_S , it needs to generate 2.495 V for the TL43xLI-Q1 when I_O reaches the target current. If the overhead voltage of 2.495 V is not acceptable, consider lower voltage reference devices such as the TLV43x-Q1 or TLVH43x-Q1.

The output current accuracy is determined by both the accuracy of TL43xLI-Q1 chosen, as well as the accuracy of the sense resistor R_S . The internal virtual reference voltage of TL43xLI-Q1 is within the range of 2.495 V \pm (0.5% or 1.0%), depending on which version is being used. Another consideration for the output current accuracy is the temperature coefficient of the TL43xLI-Q1 and R_S . Refer to the [Electrical Characteristics](#) of these parameters.

10.2.5.2.2 Power Consumption

For TL43xLI-Q1 to properly be used as a control component in this circuit, the minimum operating current needs to be reached. This is accomplished by setting the external biasing resistor in series with the TL43xLI-Q1.

For TL43xLI, the minimum operating current is 0.6 mA and with margin consideration, most of the designs set this current to be higher than 0.6 mA. To achieve lower power consumption, consider devices such as the ATL43x-Q1 and ATL43xLI-Q1.

10.2.6 Shunt Regulator/Reference

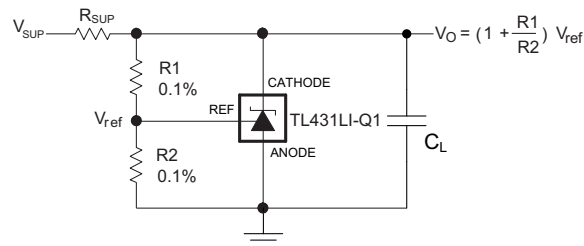

Figure 23. Shunt Regulator Schematic

10.2.6.1 Design Requirements

For this design example, use the parameters listed in [Table 1](#) as the input parameters.

Table 3. Design Parameters

DESIGN PARAMETER	EXAMPLE VALUE
Reference Initial Accuracy	1.0%
Supply Voltage	24 V
Cathode Current (I _k)	5 mA
Output Voltage Level	2.495 V–36 V
Load Capacitance	2 μF
Feedback Resistor Values and Accuracy (R1 and R2)	10 kΩ

10.2.6.2 Detailed Design Procedure

When using TL43xLI-Q1 as a shunt regulator, determine the following:

- Input voltage range
- Temperature range
- Total accuracy
- Cathode current
- Reference initial accuracy
- Output capacitance

10.2.6.2.1 Programming Output/Cathode Voltage

To program the cathode voltage to a regulated voltage, a resistive bridge must be shunted between the cathode and anode pins with the mid point tied to the reference pin. This can be seen in [Figure 23](#), with R1 and R2 being the resistive bridge. The cathode/output voltage in the shunt regulator configuration can be approximated by the equation shown in [Figure 23](#). The cathode voltage can be more accurately determined by taking in to account the cathode current:

$$V_O = (1 + R1/R2)V_{REF} - I_{REF}R1 \quad (1)$$

For this equation to be valid, TL43xLI-Q1 must be fully biased so that it has enough open loop gain to mitigate any gain error. This can be done by meeting the I_{min} spec denoted in the [Specifications](#).

10.2.6.2.2 Total Accuracy

When programming the output above unity gain ($V_{KA}=V_{REF}$), TL43xLI-Q1 is susceptible to other errors that can effect the overall accuracy beyond V_{REF} . These errors include:

- R1 and R2 accuracies
- $V_{I(dev)}$: Change in reference voltage over temperature
- $\Delta V_{REF} / \Delta V_{KA}$: Change in reference voltage to the change in cathode voltage
- $|z_{KA}|$ - Dynamic impedance, causing a change in cathode voltage with cathode current

Worst case cathode voltage can be determined taking all of the variables in to account. The [Setting the Shunt Voltage on an Adjustable Shunt Regulator Application Note](#) assists designers in setting the shunt voltage to achieve optimum accuracy for this device.

10.2.6.2.3 Stability

Though TL43xLI-Q1 is stable with no capacitive load, the device that receives the output voltage of the shunt regulator can presents a capacitive load that is within the TL43xLI-Q1 region of stability, shown in [Figure 12](#). Also, designers can use capacitive loads to improve the transient response or for power supply decoupling. When using additional capacitance between Cathode and Anode, refer to [Figure 12](#). Also, the [Understanding Stability Boundary Conditions Charts in TL431, TL432 Data Sheet Application Note](#) provides a deeper understanding of this devices stability characteristics and aids the user in making the right choices when choosing a load capacitor.

10.2.6.2.4 Start-up Time

As shown in [Figure 24](#), TL43xLI-Q1 has a fast response up to approximately 2 V and then slowly charges to the programmed value. This is due to the compensation capacitance (shown in [Figure 19](#)) the TL43xLI-Q1 has to meet the stability criteria. Despite the secondary delay, TL43xLI-Q1 still has a fast response suitable for many clamp applications.

10.2.6.3 Application Curves

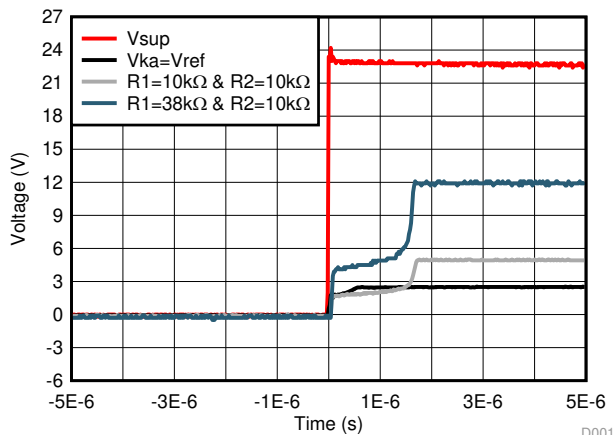

Figure 24. TL43xLI-Q1 Start-Up Response

10.2.7 Isolated Flyback with Optocoupler

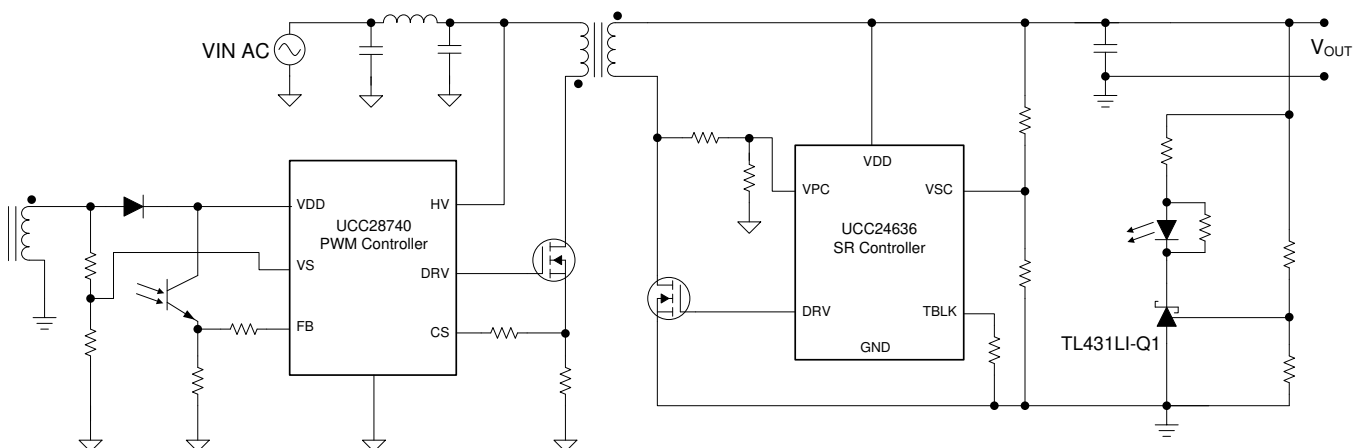

Figure 25. Isolated Flyback with Optocoupler

10.2.7.1 Design Requirements

The TL431LI-Q1 is used in the feedback network on the secondary side in an isolated flyback with optocoupler design. Figure 25 shows the simplified flyback converter with the TL431LI-Q1. For this design example, use the parameters in Table 4 as the input parameters. In this example, a simplified design procedure will be discussed. The compensation network for the feedback network is beyond the scope of this section. Details on compensation network can be found in the [Compensation Design with TL431 for UCC28600 Application Report](#).

Table 4. Design Parameters

DESIGN PARAMETER	EXAMPLE VALUE
Voltage Output	15 V
Secondary Side Feedback Loop Accuracy	< 3%

10.2.7.2 Detailed Design Procedure

The goal of this design is to design a high accuracy feedback network to meet 3% V_{OUT} accuracy requirements over the full temperature range. To meet the design requirements, the total secondary side feedback loop error has to be below 3%. To meet these requirements, it is necessary to take full advantage of the improved temperature drift, $I_{ref(min)}$, and $I_{I(dev)}$ of the TL431LI-Q1.

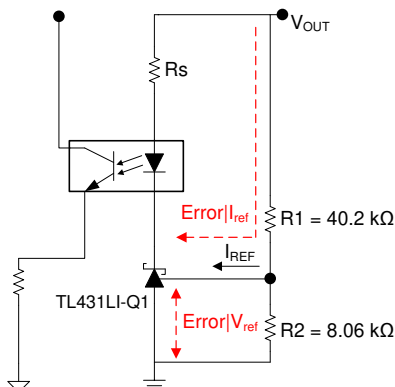

Figure 26. Feedback Quiescent Current

10.2.7.2.1 TL431 Feedback Loop Error Calculation

Figure 26 shows the simplified version of the feedback network. The accuracy of the output voltage is dependent on the regulation voltage accuracy of the TL431LI-Q1. A simplified V_{OUT} can be seen in Equation 2, but this equation does not include errors that deviates the output.

$$\begin{aligned}
 V_{OUT} &= V_{ref} \times \left(1 + \frac{R1}{R2}\right) + R1 \times (I_{ref}) \\
 V_{OUT} &= (2.495 \text{ V}) \times \left(1 + \frac{40.2\text{k}\Omega}{8.06\text{k}\Omega}\right) + 40.2\text{k}\Omega \times (0.4\mu\text{A}) \\
 V_{OUT} &= 14.955 \text{ V}
 \end{aligned} \tag{2}$$

The primary sources of error are the $\text{Error}|_{V_{ref}}$ and $\text{Error}|_{I_{ref}}$. The $\text{Error}|_{V_{ref}}$ primarily consists of the errors that affect the internal bandgap voltage reference of the TL431LI-Q1. This consists of errors from the initial accuracy, temperature drift, ratio of change in reference voltage to the change in cathode voltage, and dynamic impedance. The benefit of the TL431LI-Q1 is its low temperature drift, $V_{I(dev)}$, which allows the V_{ref} to be more accurate across the full temperature range compared to typical TL431LI-Q1 devices. Equation 3 shows a simplified worst case V_{ref} with initial accuracy and temperature drift.

$$\begin{aligned}
 V_{ref}(\text{Error}|_{V_{ref}}) &= V_{ref} \times (1 + \text{Initial Accuracy}) + V_{I(dev)} + \dots \\
 V_{ref}(\text{Error}|_{V_{ref}}) &= 2.495 \text{ V} \times (1 + 0.5\%) + 17 \text{ mV} + \dots \\
 V_{ref}(\text{Error}|_{V_{ref}}) &\approx 2.524 \text{ V}
 \end{aligned} \tag{3}$$

The $\text{Error}|_{I_{ref}}$ in Figure 26 is dependent on the I_{ref} and $I_{I(dev)}$ along with R1. The TL431LI-Q1 has improved I_{ref} and $I_{I(dev)}$ which allows the values of the resistor R1 to be increased to save power. Typically optocoupler feedback design requires the I_{ref} to be taken into account when doing V_{OUT} calculations but the error comes from the deviation from the maximum to typical value of I_{ref} . In addition to this, the $I_{I(dev)}$ is the temperature deviation on the I_{ref} current which affects the overall reference current into the TL431LI-Q1. Equation 4 shows the V_{OUT} of the TL431LI-Q1 for Figure 26, which includes the improved I_{ref} and $I_{I(dev)}$. The V_{OUT} equation assumes that the resistors R1 and R2 have a 0.5% accuracy tolerance.

$$\begin{aligned}
 V_{OUT}(\text{Error}|_{I_{ref}}) &= V_{ref}(\text{Error}|_{V_{ref}}) \times \left(1 + \frac{R1}{R2}\right) + R1 \times (I_{ref} + I_{I(dev)}) \\
 V_{OUT}(\text{Error}|_{I_{ref}}) &= (2.495 \text{ V} \times (1 + 0.5\%) + 0.017 \text{ V}) \times \left(1 + \frac{40.2\text{k}\Omega \times (1 + 0.5\%)}{8.06\text{k}\Omega \times (1 - 0.5\%)}\right) \\
 &\quad + 40.2\text{k}\Omega \times (1 + 0.5\%) \times (0.4\mu\text{A} + 0.3\mu\text{A}) \\
 V_{OUT} &= 15.270 \text{ V}
 \end{aligned} \tag{4}$$

Comparing the calculated V_{OUT} without and with error, the expected worst case max error is 2.1% which meets the 3% error target.

10.3 System Examples

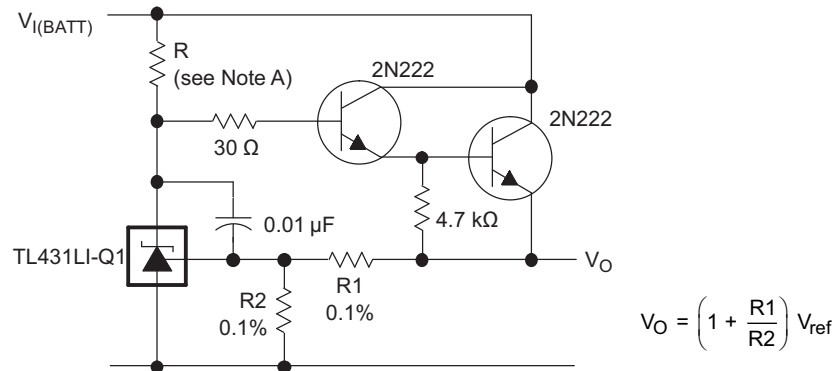

R should provide cathode current ≥ 0.6 mA to the TL431LI-Q1 at minimum $V_{I(BATT)}$.

Figure 27. Precision High-Current Series Regulator

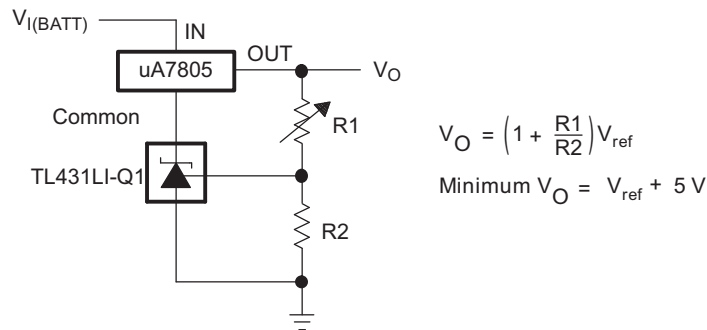

Figure 28. Output Control of a Three-Terminal Fixed Regulator

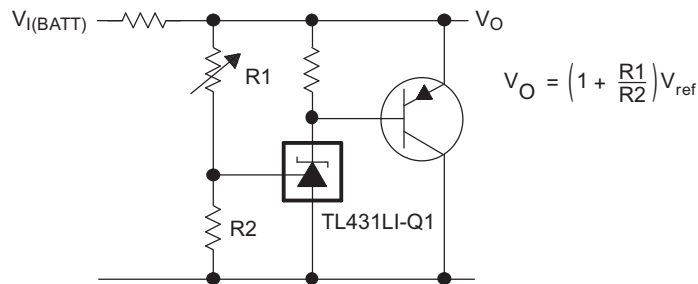
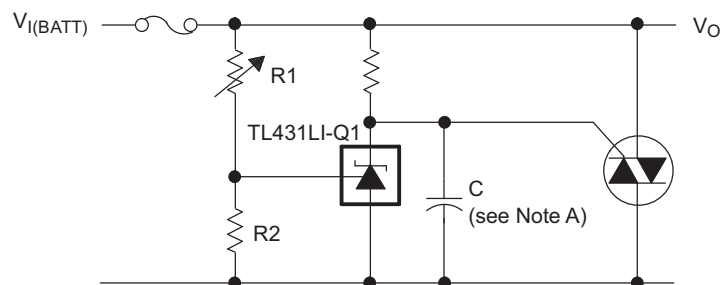

Figure 29. High-Current Shunt Regulator



Refer to the stability boundary conditions in [Figure 12](#) to determine allowable values for C.

Figure 30. Crowbar Circuit

System Examples (continued)

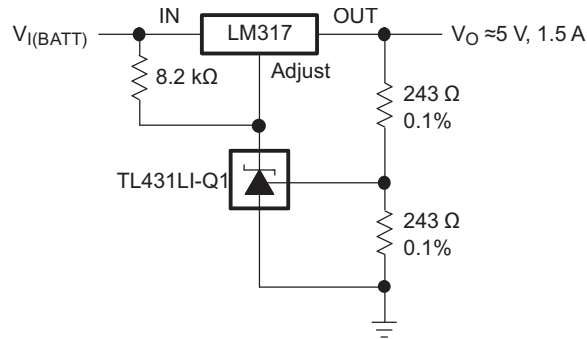
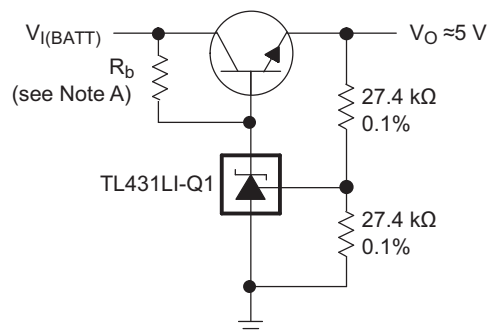

Figure 31. Precision 5-V, 1.5-A Regulator



R_b should provide cathode current ≥ 0.6 mA to the TL431LI-Q1.

Figure 32. Efficient 5-V Low-Dropout (LDO) Regulator Configuration

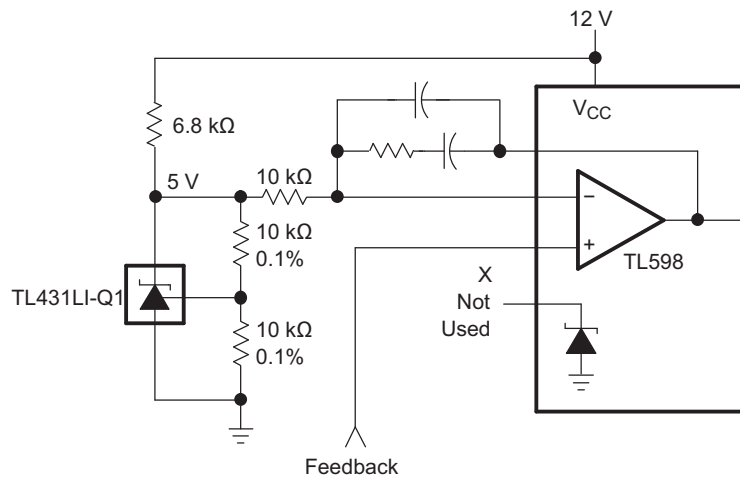
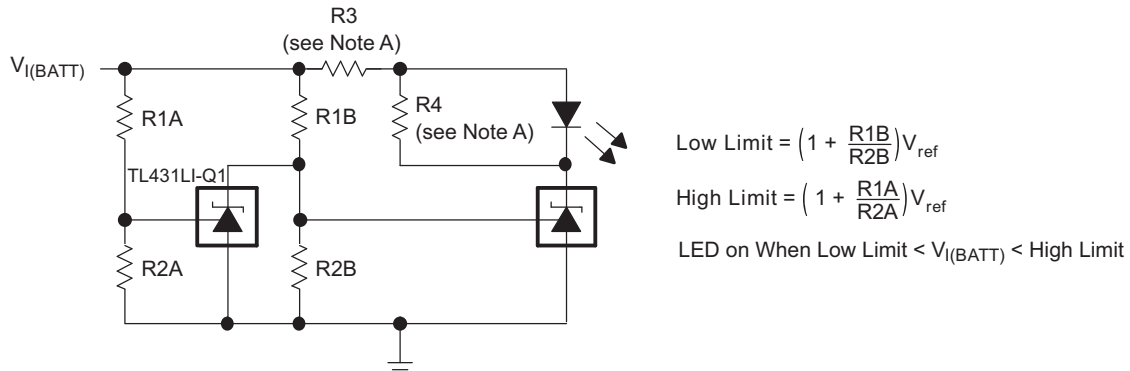

Figure 33. PWM Converter With Reference

System Examples (continued)



Select R3 and R4 to provide the desired LED intensity and cathode current ≥ 0.6 mA to the TL431LI-Q1 at the available $V_{I(BATT)}$.

Figure 34. Voltage Monitor

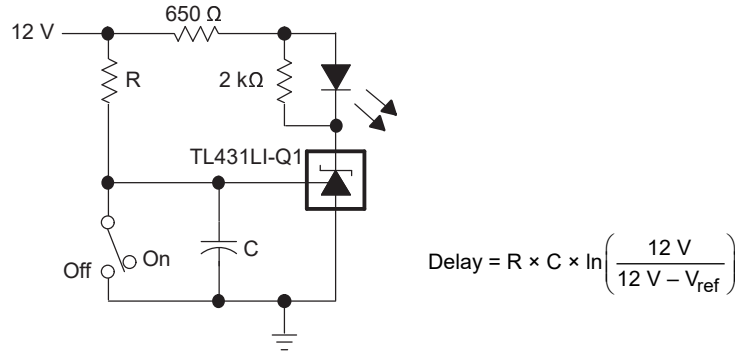

Figure 35. Delay Timer

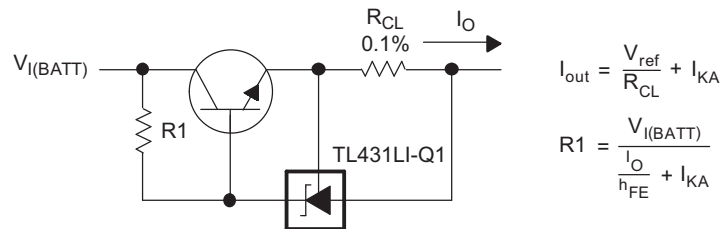

Figure 36. Precision Current Limiter

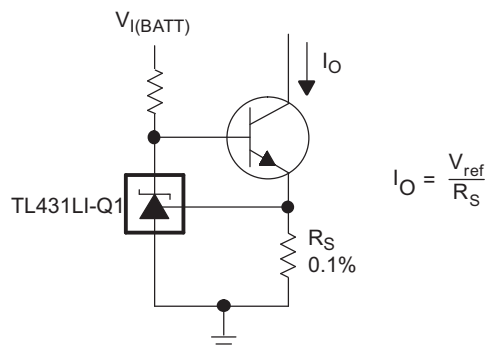

Figure 37. Precision Constant-Current Sink

11 Power Supply Recommendations

When using TL43xLI-Q1 as a Linear Regulator to supply a load, designers typically use a bypass capacitor on the output/cathode pin. When doing this, be sure that the capacitance is within the stability criteria shown in [Figure 12](#).

To not exceed the maximum cathode current, be sure that the supply voltage is current limited. Also, be sure to limit the current being driven into the Ref pin, as not to exceed the absolute maximum rating.

For applications shunting high currents, pay attention to the cathode and anode trace lengths, adjusting the width of the traces to have the proper current density.

12 Layout

12.1 Layout Guidelines

Bypass capacitors must be placed as close to the part as possible. Current-carrying traces need to have widths appropriate for the amount of current they are carrying; in the case of the TL43xLI-Q1, these currents are low.

12.2 Layout Example

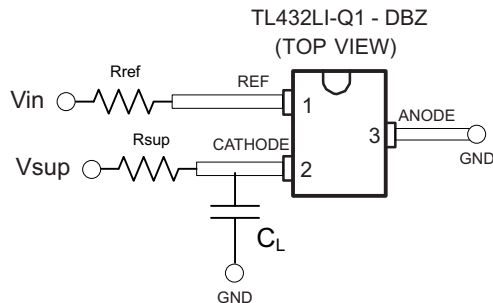

Figure 38. DBZ Layout Example

13 Device and Documentation Support

13.1 Device Support

13.1.1 Device Nomenclature

TI assigns suffixes and prefixes to differentiate all the combinations of the TL43xLI-Q1 family. More details and possible orderable combinations are located in the Package Option Addendum.

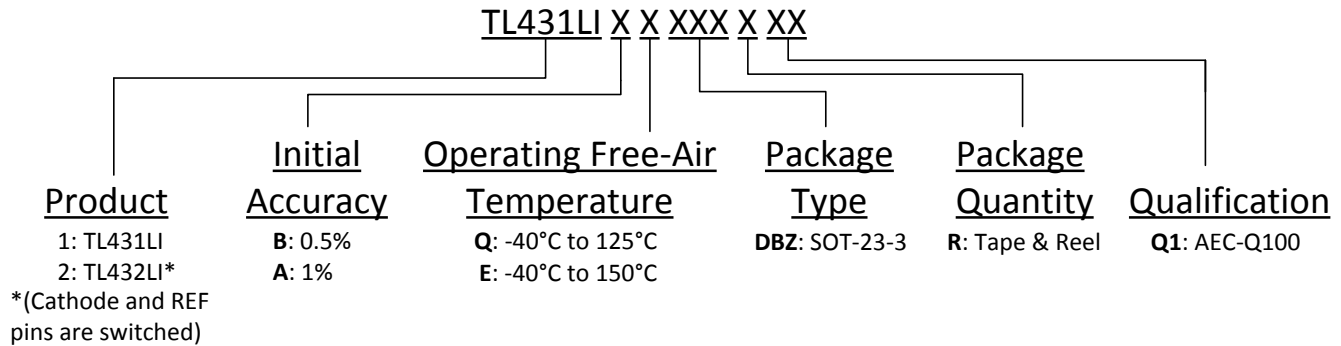

13.2 Documentation Support

13.2.1 Related Documentation

For related documentation see the following:

- Texas Instruments, [Understanding Stability Boundary Conditions Charts in TL431, TL432 Data Sheet](#)
- Texas Instruments, [Setting the Shunt Voltage on an Adjustable Shunt Regulator](#)
- Texas Instruments, [Designing With the Improved TL431LI](#)

13.3 Related Links

The table below lists quick access links. Categories include technical documents, support and community resources, tools and software, and quick access to order now.

Table 5. Related Links

PARTS	PRODUCT FOLDER	ORDER NOW	TECHNICAL DOCUMENTS	TOOLS & SOFTWARE	SUPPORT & COMMUNITY
TL431LI-Q1	Click here	Click here	Click here	Click here	Click here
TL432LI-Q1	Click here	Click here	Click here	Click here	Click here

13.4 Receiving Notification of Documentation Updates

To receive notification of documentation updates, navigate to the device product folder on ti.com. In the upper right corner, click on *Alert me* to register and receive a weekly digest of any product information that has changed. For change details, review the revision history included in any revised document.

13.5 Support Resources

TI E2E™ support forums are an engineer's go-to source for fast, verified answers and design help — straight from the experts. Search existing answers or ask your own question to get the quick design help you need.

Linked content is provided "AS IS" by the respective contributors. They do not constitute TI specifications and do not necessarily reflect TI's views; see TI's [Terms of Use](#).

13.6 Trademarks

E2E is a trademark of Texas Instruments.
All other trademarks are the property of their respective owners.

13.7 Electrostatic Discharge Caution



This integrated circuit can be damaged by ESD. Texas Instruments recommends that all integrated circuits be handled with appropriate precautions. Failure to observe proper handling and installation procedures can cause damage.

ESD damage can range from subtle performance degradation to complete device failure. Precision integrated circuits may be more susceptible to damage because very small parametric changes could cause the device not to meet its published specifications.

13.8 Glossary

[SLYZ022](#) — *TI Glossary*.

This glossary lists and explains terms, acronyms, and definitions.

14 Mechanical, Packaging, and Orderable Information

The following pages include mechanical, packaging, and orderable information. This information is the most current data available for the designated devices. This data is subject to change without notice and revision of this document. For browser-based versions of this data sheet, refer to the left-hand navigation.

PACKAGING INFORMATION

Orderable Device	Status (1)	Package Type	Package Drawing	Pins	Package Qty	Eco Plan (2)	Lead finish/ Ball material (6)	MSL Peak Temp (3)	Op Temp (°C)	Device Marking (4/5)	Samples
TL431LIAEDBZRQ1	ACTIVE	SOT-23	DBZ	3	3000	RoHS & Green	NIPDAU	Level-1-260C-UNLIM	-40 to 150	23CP	Samples
TL431LIAQDBZRQ1	ACTIVE	SOT-23	DBZ	3	3000	RoHS & Green	NIPDAU	Level-1-260C-UNLIM	-40 to 125	22TP	Samples
TL431LIBEDBZRQ1	ACTIVE	SOT-23	DBZ	3	3000	RoHS & Green	NIPDAU	Level-1-260C-UNLIM	-40 to 150	23DP	Samples
TL431LIBQDBZRQ1	ACTIVE	SOT-23	DBZ	3	3000	RoHS & Green	NIPDAU	Level-1-260C-UNLIM	-40 to 125	22UP	Samples
TL432LIAEDBZRQ1	ACTIVE	SOT-23	DBZ	3	3000	RoHS & Green	NIPDAU	Level-1-260C-UNLIM	-40 to 150	23EP	Samples
TL432LIAQDBZRQ1	ACTIVE	SOT-23	DBZ	3	3000	RoHS & Green	NIPDAU	Level-1-260C-UNLIM	-40 to 125	22VP	Samples
TL432LIBEDBZRQ1	ACTIVE	SOT-23	DBZ	3	3000	RoHS & Green	NIPDAU	Level-1-260C-UNLIM	-40 to 150	23FP	Samples
TL432LIBQDBZRQ1	ACTIVE	SOT-23	DBZ	3	3000	RoHS & Green	NIPDAU	Level-1-260C-UNLIM	-40 to 125	22WP	Samples

(1) The marketing status values are defined as follows:

ACTIVE: Product device recommended for new designs.

LIFEBUY: TI has announced that the device will be discontinued, and a lifetime-buy period is in effect.

NRND: Not recommended for new designs. Device is in production to support existing customers, but TI does not recommend using this part in a new design.

PREVIEW: Device has been announced but is not in production. Samples may or may not be available.

OBSOLETE: TI has discontinued the production of the device.

(2) **RoHS:** TI defines "RoHS" to mean semiconductor products that are compliant with the current EU RoHS requirements for all 10 RoHS substances, including the requirement that RoHS substance do not exceed 0.1% by weight in homogeneous materials. Where designed to be soldered at high temperatures, "RoHS" products are suitable for use in specified lead-free processes. TI may reference these types of products as "Pb-Free".

RoHS Exempt: TI defines "RoHS Exempt" to mean products that contain lead but are compliant with EU RoHS pursuant to a specific EU RoHS exemption.

Green: TI defines "Green" to mean the content of Chlorine (Cl) and Bromine (Br) based flame retardants meet JS709B low halogen requirements of <=1000ppm threshold. Antimony trioxide based flame retardants must also meet the <=1000ppm threshold requirement.

(3) MSL, Peak Temp. - The Moisture Sensitivity Level rating according to the JEDEC industry standard classifications, and peak solder temperature.

(4) There may be additional marking, which relates to the logo, the lot trace code information, or the environmental category on the device.

(5) Multiple Device Markings will be inside parentheses. Only one Device Marking contained in parentheses and separated by a "~" will appear on a device. If a line is indented then it is a continuation of the previous line and the two combined represent the entire Device Marking for that device.

⁽⁶⁾ Lead finish/Ball material - Orderable Devices may have multiple material finish options. Finish options are separated by a vertical ruled line. Lead finish/Ball material values may wrap to two lines if the finish value exceeds the maximum column width.

Important Information and Disclaimer: The information provided on this page represents TI's knowledge and belief as of the date that it is provided. TI bases its knowledge and belief on information provided by third parties, and makes no representation or warranty as to the accuracy of such information. Efforts are underway to better integrate information from third parties. TI has taken and continues to take reasonable steps to provide representative and accurate information but may not have conducted destructive testing or chemical analysis on incoming materials and chemicals. TI and TI suppliers consider certain information to be proprietary, and thus CAS numbers and other limited information may not be available for release.

In no event shall TI's liability arising out of such information exceed the total purchase price of the TI part(s) at issue in this document sold by TI to Customer on an annual basis.

OTHER QUALIFIED VERSIONS OF TL431LI-Q1, TL432LI-Q1 :

- Catalog: [TL431LI](#), [TL432LI](#)

NOTE: Qualified Version Definitions:

- Catalog - TI's standard catalog product

TAPE AND REEL INFORMATION



QUADRANT ASSIGNMENTS FOR PIN 1 ORIENTATION IN TAPE



*All dimensions are nominal

Device	Package Type	Package Drawing	Pins	SPQ	Reel Diameter (mm)	Reel Width W1 (mm)	A0 (mm)	B0 (mm)	K0 (mm)	P1 (mm)	W (mm)	Pin1 Quadrant
TL431LIAEDBZRQ1	SOT-23	DBZ	3	3000	178.0	9.0	3.15	2.77	1.22	4.0	8.0	Q3
TL431LIAQDBZRQ1	SOT-23	DBZ	3	3000	178.0	9.0	3.15	2.77	1.22	4.0	8.0	Q3
TL431LIBEDBZRQ1	SOT-23	DBZ	3	3000	178.0	9.0	3.15	2.77	1.22	4.0	8.0	Q3
TL431LIBQDBZRQ1	SOT-23	DBZ	3	3000	178.0	9.0	3.15	2.77	1.22	4.0	8.0	Q3
TL432LIAEDBZRQ1	SOT-23	DBZ	3	3000	178.0	9.0	3.15	2.77	1.22	4.0	8.0	Q3
TL432LIAQDBZRQ1	SOT-23	DBZ	3	3000	178.0	9.0	3.15	2.77	1.22	4.0	8.0	Q3
TL432LIBEDBZRQ1	SOT-23	DBZ	3	3000	178.0	9.0	3.15	2.77	1.22	4.0	8.0	Q3
TL432LIBQDBZRQ1	SOT-23	DBZ	3	3000	178.0	9.0	3.15	2.77	1.22	4.0	8.0	Q3

TAPE AND REEL BOX DIMENSIONS

*All dimensions are nominal

Device	Package Type	Package Drawing	Pins	SPQ	Length (mm)	Width (mm)	Height (mm)
TL431LIAEDBZRQ1	SOT-23	DBZ	3	3000	180.0	180.0	18.0
TL431LIAQDBZRQ1	SOT-23	DBZ	3	3000	180.0	180.0	18.0
TL431LIBEDBZRQ1	SOT-23	DBZ	3	3000	180.0	180.0	18.0
TL431LIBQDBZRQ1	SOT-23	DBZ	3	3000	180.0	180.0	18.0
TL432LIAEDBZRQ1	SOT-23	DBZ	3	3000	180.0	180.0	18.0
TL432LIAQDBZRQ1	SOT-23	DBZ	3	3000	180.0	180.0	18.0
TL432LIBEDBZRQ1	SOT-23	DBZ	3	3000	180.0	180.0	18.0
TL432LIBQDBZRQ1	SOT-23	DBZ	3	3000	180.0	180.0	18.0

EXAMPLE BOARD LAYOUT

DBZ0003A

SOT-23 - 1.12 mm max height

SMALL OUTLINE TRANSISTOR

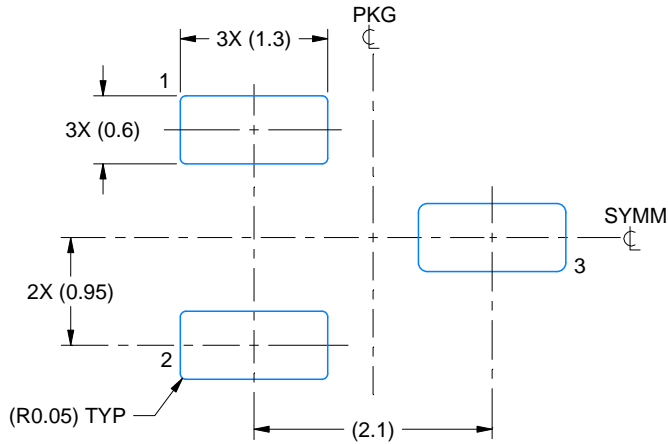

LAND PATTERN EXAMPLE
SCALE:15X

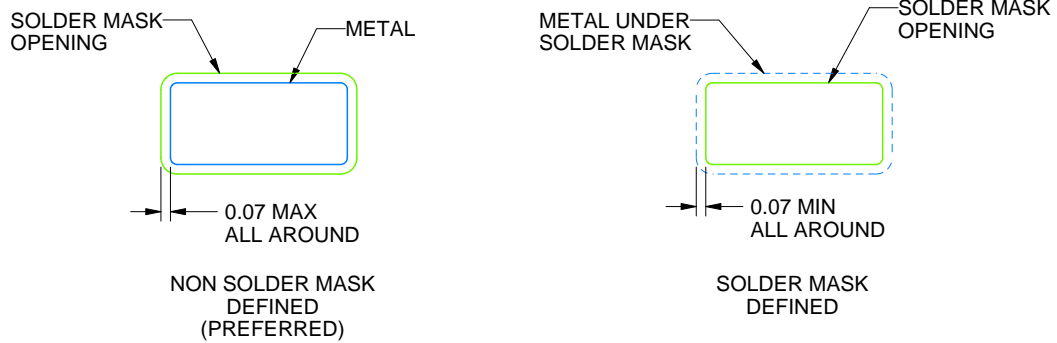

SOLDER MASK DETAILS

4214838/E 06/2024

NOTES: (continued)

5. Publication IPC-7351 may have alternate designs.
6. Solder mask tolerances between and around signal pads can vary based on board fabrication site.

EXAMPLE STENCIL DESIGN

DBZ0003A

SOT-23 - 1.12 mm max height

SMALL OUTLINE TRANSISTOR

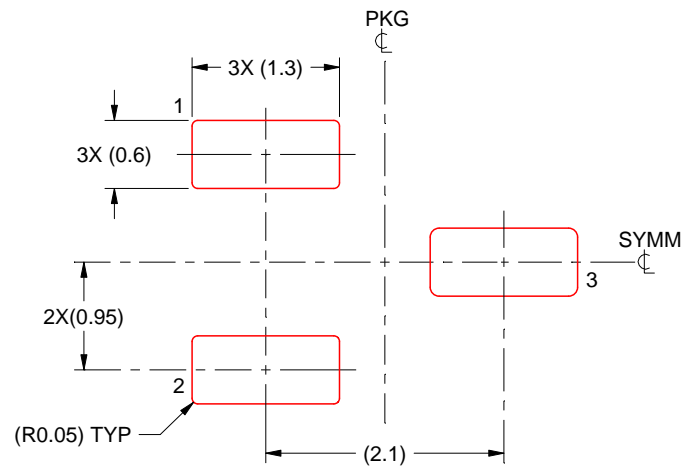

SOLDER PASTE EXAMPLE
BASED ON 0.125 THICK STENCIL
SCALE:15X

4214838/E 06/2024

NOTES: (continued)

7. Laser cutting apertures with trapezoidal walls and rounded corners may offer better paste release. IPC-7525 may have alternate design recommendations.
8. Board assembly site may have different recommendations for stencil design.

IMPORTANT NOTICE AND DISCLAIMER

TI PROVIDES TECHNICAL AND RELIABILITY DATA (INCLUDING DATA SHEETS), DESIGN RESOURCES (INCLUDING REFERENCE DESIGNS), APPLICATION OR OTHER DESIGN ADVICE, WEB TOOLS, SAFETY INFORMATION, AND OTHER RESOURCES "AS IS" AND WITH ALL FAULTS, AND DISCLAIMS ALL WARRANTIES, EXPRESS AND IMPLIED, INCLUDING WITHOUT LIMITATION ANY IMPLIED WARRANTIES OF MERCHANTABILITY, FITNESS FOR A PARTICULAR PURPOSE OR NON-INFRINGEMENT OF THIRD PARTY INTELLECTUAL PROPERTY RIGHTS.

These resources are intended for skilled developers designing with TI products. You are solely responsible for (1) selecting the appropriate TI products for your application, (2) designing, validating and testing your application, and (3) ensuring your application meets applicable standards, and any other safety, security, regulatory or other requirements.

These resources are subject to change without notice. TI grants you permission to use these resources only for development of an application that uses the TI products described in the resource. Other reproduction and display of these resources is prohibited. No license is granted to any other TI intellectual property right or to any third party intellectual property right. TI disclaims responsibility for, and you will fully indemnify TI and its representatives against, any claims, damages, costs, losses, and liabilities arising out of your use of these resources.

TI's products are provided subject to [TI's Terms of Sale](#) or other applicable terms available either on [ti.com](https://www.ti.com) or provided in conjunction with such TI products. TI's provision of these resources does not expand or otherwise alter TI's applicable warranties or warranty disclaimers for TI products.

TI objects to and rejects any additional or different terms you may have proposed.

Mailing Address: Texas Instruments, Post Office Box 655303, Dallas, Texas 75265
Copyright © 2024, Texas Instruments Incorporated

Looking for pricing, stock, or lifecycle information?

Click below to explore more details on WIN SOURCE:

- ⊖ [View DF11-24DS-2C on WIN SOURCE](#)
- ⊖ [Hirose Electric Co Ltd Information](#)

Optimize Your Supply Chain with WIN SOURCE Solutions

- ✓ Global Sourcing Solution
- ✓ Obsolete Management
- ✓ Cost Control Management
- ✓ Shortage Management
- ✓ Alternative Solution
- ✓ Excess Inventory Management