



**THE DATASHEET OF  
Z0220516SSGR3641**





# Z02205

**MODEM CONTROLLER IDEAL FOR LOW POWER  
CONSUMPTION, SMALL SIZE REQUIREMENTS**

PRODUCT SPECIFICATION

PS001000-MOD0599



---

©1999 by ZiLOG, Inc. All rights reserved. Information in this publication concerning the devices, applications, or technology described is intended to suggest possible uses and may be superseded. ZiLOG, INC. DOES NOT ASSUME LIABILITY FOR OR PROVIDE A REPRESENTATION OF ACCURACY OF THE INFORMATION, DEVICES, OR TECHNOLOGY DESCRIBED IN THIS DOCUMENT. ZiLOG ALSO DOES NOT ASSUME LIABILITY FOR INTELLECTUAL PROPERTY INFRINGEMENT RELATED IN ANY MANNER TO USE OF INFORMATION, DEVICES, OR TECHNOLOGY DESCRIBED HEREIN OR OTHERWISE. Except with the express written approval of ZiLOG, use of information, devices, or technology as critical components of life support systems is not authorized. No licenses are conveyed, implicitly or otherwise, by this document under any intellectual property rights.



*Totally Logical*

## Z02205

MODEM CONTROLLER IDEAL FOR LOW POWER CONSUMPTION, SMALL SIZE REQUIREMENTS

### FEATURES

Device	ROM (KB)	RAM* (Bytes)	Speed (MHz)
Z02205	16	237	16

- Includes AT command set interpreter in on-chip ROM—no external memory required
- Supports Tone dial or Pulse dial
- Call progress monitoring controls
- Handshake controls
- Guard Tone controls
- Line quality monitoring and Auto-Retrain

- Auto-Dial and Auto-Answer
- Glueless interface to Z02201 modem data pump
- Watch-Dog Timer (WDT)/Power-On Reset (POR)
- Type-I Caller ID
- Dynamic power management
- CMOS design for low power consumption
- 0°C to +70°C commercial temperature range
- 28-pin DIP, SOIC package
- 4.5V to 5.5V operating range

### GENERAL DESCRIPTION

The Z02205 V.22bis Modem Controller serves as the modem controller in embedded V.22bis modem applications. A complete modem can be made by adding ZiLOG data pump (Z02201), phone line interface, and the required DTE interface. The Z02205 has been designed for low-cost use and includes a glueless interface to the ZiLOG data pumps. The Z02205 is ideal for applications where small size and low power consumption are requirements.

The Z02205 operates over dial-up telephone connections, provides auto-dial and ring detect, and operates in either SYNC or ASYNC modes.

The Z02205 includes AT command and modem control firmware in on-chip ROM. It also includes enhanced wake-up circuitry, programmable Watch-Dog Timers (WDT), and low-noise/EMI options.

AT commands stored on-chip in ROM provide control over the following modem controller functions:

- Call progress monitoring
- Handshake negotiation
- Dial controls—pulse or tone
- S-registers
- Auto-answer and auto-dial
- Guard tones
- On-hook and off-hook
- Auto-retrain

Standard Z02205 sample devices and demonstration boards contain controller code tailored for operation on the North American phone network. For production usage, customers must modify the controller code to meet the requirements of their particular country and application.

**Note:** All signals with an overline, are active Low. For example,  $\overline{B/W}$ , in which WORD is active Low; and  $\overline{B/W}$ , in which BYTE is active Low.

Power connections follow conventional descriptions below:

Connection	Circuit	Device
Power	V <sub>CC</sub>	V <sub>DD</sub>
Ground	GND	V <sub>SS</sub>

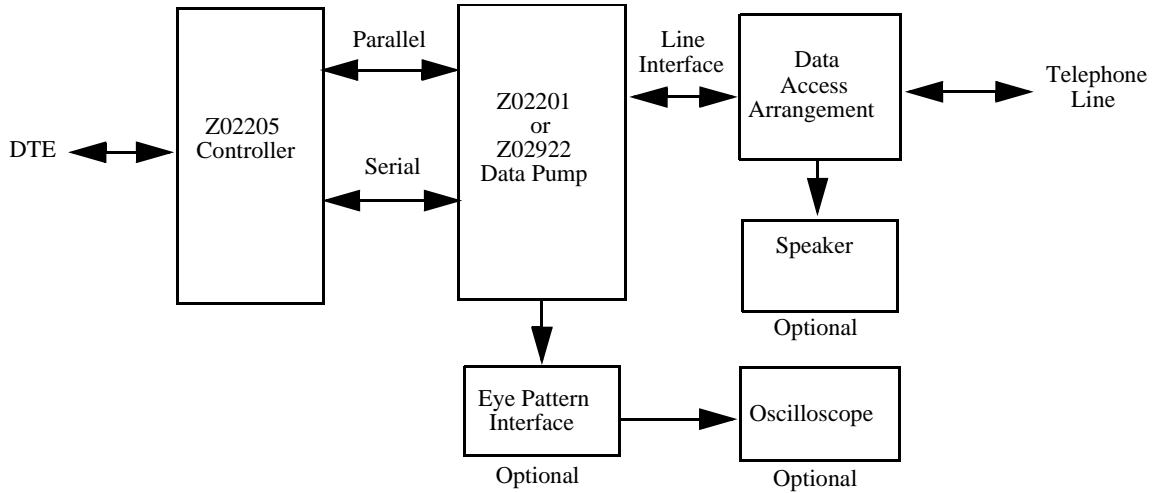

**Figure 1. Functional Block Diagram**

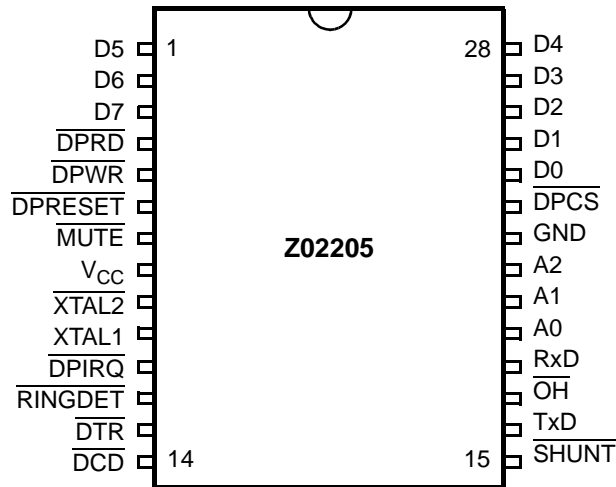

**Figure 2. Z02205 Pin Diagram (SOIC/ DIP)**

## PIN DESCRIPTION

Table 1. Z02205 Pin Identification

Pin #	Symbol	Function	Direction
1–3	D5–D7	DSP Register Data Lines 5 through 7	In/Output
4	$\overline{\text{DPRD}}$	Data Pump Read	Output
5	$\overline{\text{DPWR}}$	Data Pump Write	Output
6	$\overline{\text{DPRESET}}$	Data Pump Reset	Output
7	$\overline{\text{MUTE}}$	Speaker Mute	Output
8	V <sub>CC</sub>	Power Supply	
9	$\overline{\text{XTAL2}}$	Crystal Oscillator	Output
10	XTAL1	Crystal Oscillator	Input
11	$\overline{\text{DPIRQ}}$	Data Pump Interrupt Request	Input
12	$\overline{\text{RINGDET}}$	Ring Detect Input	Input
13	$\overline{\text{DTR}}$	Data Terminal Ready	Input
14	$\overline{\text{DCD}}$	Data Carrier Detect	Output
15	$\overline{\text{SHUNT}}$	Pulse Dial Shunt Relay Output	Output
16	TxD	Data Transmit	Output
17	$\overline{\text{OH}}$	Off Hook Relay Output	Output
18	RxD	Data Receive	Input
19–21	A0–A2	DSP Register Address Lines 0 through 2	Output
22	GND	Ground	
23	$\overline{\text{DPCS}}$	Data Pump Chip Select	Output
24–28	D0–D4	DSP Register Data Lines 0 through 4	In/Output

## ABSOLUTE MAXIMUM RATINGS

Parameter	Min	Max	Units	Notes
Ambient Temperature under Bias	0	+70	C	
Storage Temperature	-65	+150	C	
Voltage on any Pin with Respect to $V_{SS}$	-0.6	+7	V	1
Voltage on $V_{DD}$ Pin with Respect to $V_{SS}$	-0.3	+7	V	
Voltage on XTAL1 and $\overline{\text{RESET}}$ Pins with Respect to $V_{SS}$	-0.6	$V_{DD}+1$	V	2
Total Power Dissipation		1.21	W	
Maximum Allowable Current out of $V_{SS}$		220	mA	
Maximum Allowable Current into $V_{DD}$		180	mA	
Maximum Allowable Current into an Input Pin	-600	+600	$\mu\text{A}$	3
Maximum Allowable Current into an Open-Drain Pin	-600	+600	$\mu\text{A}$	4
Maximum Allowable Output Current Sunked by Any I/O Pin		25	mA	
Maximum Allowable Output Current Sourced by Any I/O Pin		25	mA	

**Notes:**

1. This applies to all pins except XTAL pins and where otherwise noted.
2. There is no input protection diode from pin to  $V_{DD}$  and current into pin is limited to  $\pm 600 \mu\text{A}$ .
3. This excludes XTAL pins.
4. Device pin is not at an output Low state.

Stresses greater than those listed under “Absolute Maximum Ratings” may cause permanent damage to the device. This rating is a stress rating only. Functional operation of the device at any condition above those indicated in the operational sections of these specifications is not implied. Ex-

posure to absolute maximum rating conditions for an extended period may affect device reliability.

Total power dissipation should not exceed 1.21 W for the package. Power dissipation is calculated as follows:

$$\text{Total Power Dissipation} = V_{DD} \times [ I_{DD} - (\text{sum of } I_{OH}) ] + \text{sum of } [ (V_{DD} - V_{OH}) \times I_{OH} ] + \text{sum of } (V_{OL} \times I_{OL})$$

## STANDARD TEST CONDITIONS

The characteristics listed below apply for standard test conditions as noted. All voltages are referenced to GND. Positive current flows into the referenced pin (Figure 3).

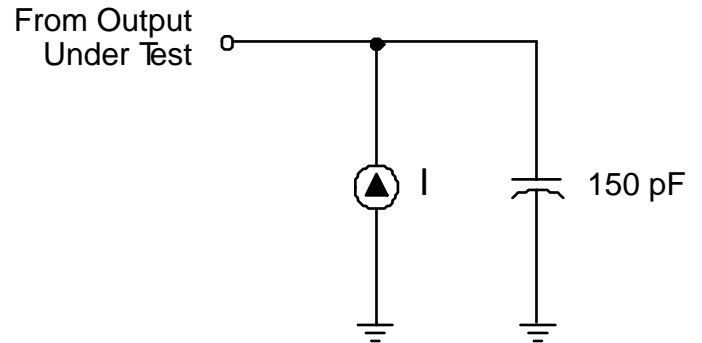

Figure 3. Test Load Diagram

## CAPACITANCE

$T_A = 25^\circ\text{C}$ ,  $V_{CC} = \text{GND} = 0\text{V}$ ,  $f = 1.0\text{ MHz}$ , Unmeasured pins to GND

Parameter	Min	Max
Input capacitance	0	12 pF
Output capacitance	0	12 pF
I/O capacitance	0	12 pF

## DC ELECTRICAL CHARACTERISTICS

Sym	Parameter	Note [3]	$V_{CC}$		$T_A = 0^\circ\text{C to } +70^\circ\text{C}$		Units	Conditions	Notes
			Min	Max	Typical [1] @ 25°C				
$V_{CH}$	Clock Input High Voltage	5.5V	$0.7 V_{CC}$	$V_{CC}+0.3$	2.6	V	Driven by External Clock Generator		
$V_{CL}$	Clock Input Low Voltage	5.5V	$\text{GND}-0.3$	$0.2 V_{CC}$	2.1	V	Driven by External Clock Generator		
$V_{IH}$	Input High Voltage	5.5V	$0.7 V_{CC}$	$V_{CC}+0.3$	2.6	V			
$V_{IL}$	Input Low Voltage	5.5V	$\text{GND}-0.3$	$0.2 V_{CC}$	1.6	V			
$V_{OH1}$	Output High Voltage	5.5V	$V_{CC}-0.4$		4.8	V	$I_{OH} = -2.0\text{ mA}$	8	
$V_{OL1}$	Output Low Voltage	5.5V		0.4	0.1	V	$I_{OL} = +4.0\text{ mA}$	8	
$V_{OL2}$	Output Low Voltage	5.5V		1.2	0.4	V	$I_{OL} = +12\text{ mA}$	8	
$V_{OFFSET}$	Comparator Input Offset Voltage	5.5V		25	10	mV		10	
$I_{IL}$	Input Leakage	5.5V	-1	2	0.004	$\mu\text{A}$	$V_{IN} = 0\text{V}$ , $V_{CC}$		
$I_{OL}$	Output Leakage	5.5V	-1	1	0.004	$\mu\text{A}$	$V_{IN} = 0\text{V}$ , $V_{CC}$		

Sym	Parameter	Note [3]	$V_{CC}$		$T_A = 0^\circ \text{C to } +70^\circ \text{C}$		Units	Conditions	Notes
			Min	Max	Typical [1] @ 25°C				
I <sub>IR</sub>	Reset Input Current	5.5V	-20	-180	-85		μA		
I <sub>CC</sub>	Supply Current	5.5V		25	20		mA	@ 16 MHz	4
I <sub>CC1</sub>	Standby Current (HALT Mode)	5.5V		8	3.7		mA	V <sub>IN</sub> = 0V, V <sub>CC</sub> @ 16 MHz	4
I <sub>CC2</sub>	Standby Current (STOP Mode)	5.5V		10	4		μA	V <sub>IN</sub> = 0V, V <sub>CC</sub> WDT is not Running	6,11
		5.5V		800	600		μA	V <sub>IN</sub> = 0V, V <sub>CC</sub> WDT is Running	6,11, 13
V <sub>ICR</sub>	Input Common Mode Voltage Range	5.5V	0	V <sub>CC</sub> -1.0V			V		10
I <sub>ALL</sub>	Auto Latch Low Current	5.5V	1.4	15	5		μA	0V < V <sub>IN</sub> < V <sub>CC</sub>	9
I <sub>ALH</sub>	Auto Latch High Current	5.5V	-1.0	-8	-6		μA	0V < V <sub>IN</sub> < V <sub>CC</sub>	9
V <sub>LV</sub>	V <sub>CC</sub> Low Voltage Protection Voltage				2.8		V	4 MHz max Int. CLK Freq.	7
			2.2	3.1	2.8		V	6 MHz max Int. CLK Freq.	7,13
V <sub>OH</sub>	Output High Voltage (Low EMI Mode)	5.0V	V <sub>CC</sub> -0.4		4.8		V	I <sub>OH</sub> = -0.5 mA	
V <sub>OL</sub>	Output Low Voltage (Low EMI Mode)	5.0V		0.4	0.1		V	I <sub>OL</sub> = 1.0 mA	

**Notes:**

1. Typicals at V<sub>CC</sub> = 5.0V.
2. GND = 0V.
3. The V<sub>DD</sub> voltage specification of 5.5V guarantees 5.0V ±0.5V with typicals at V<sub>CC</sub>-5.0V.
4. All outputs unloaded, I/O pins floating, inputs at rail.
5. CL1 = CL2 = 10 pF.
6. Same as note [4] except inputs at V<sub>CC</sub>.
7. The V<sub>LV</sub> voltage increases as the temperature decreases and will overlap lower V<sub>CC</sub> operating region.
8. Standard Mode (not Low EMI).
9. Auto Latch (Mask Option) selected.
10. For analog comparator, inputs when analog comparators are enabled.
11. Clock must be forced Low, when XTAL1 is clock-driven and XTAL2 is floating.
12. Excludes clock pins.
13. 0°C to 70°C (standard temperature).

# AC ELECTRICAL CHARACTERISTICS

## Additional Timing Diagram

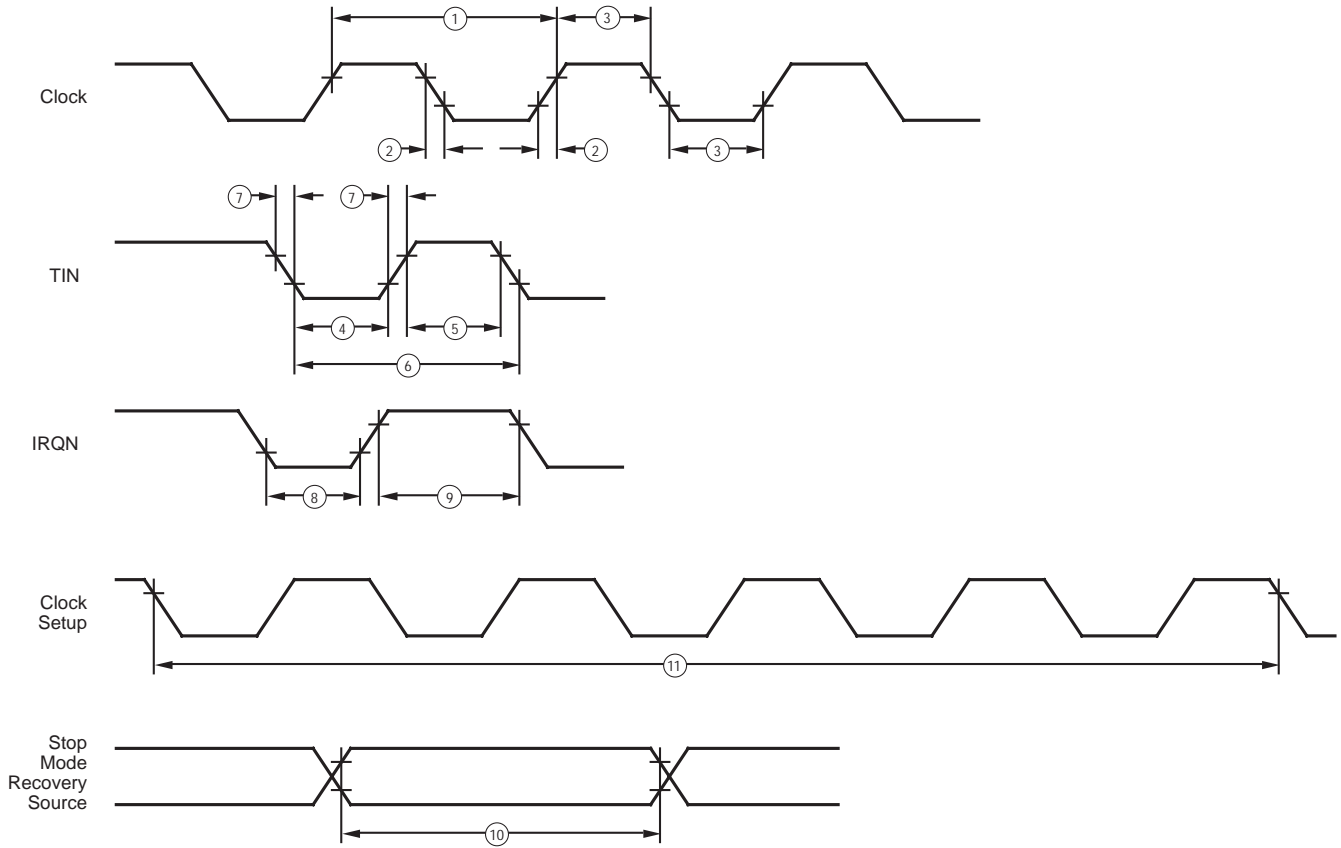

Figure 4. Additional Timing

**Additional Timing Table (SCLK/TCLK = XTAL/2)**

No	Symbol	Parameter	Note [3] V <sub>CC</sub>	T <sub>A</sub> = 0°C to +70°C		Units	Notes
				16 MHz			
				Min	Max		
1	TpC	Input Clock Period	5.5V	62.5	DC	ns	1,7
			5.5V	250	DC	ns	1,8
2	TrC,TfC	Clock Input Rise & Fall Times	5.5V		15	ns	1
3	TwC	Input Clock Width	5.5V	31		ns	1
			5.5V	125		ns	1,8
4	TwTinL	Timer Input Low Width	5.5V	70		ns	1
5	TwTinH	Timer Input High Width	5.5V	5TpC			1
6	TpTin	Timer Input Period	5.5V	8TpC			1
7	TrTin, Tftin	Timer Input Rise & Fall Timer	5.5V		100	ns	1
8A	TwIL	Int. Request Low Time	5.5V	70		ns	1,2
8B	TwIL	Int. Request Low Time	5.5V	5TpC			1,3
9	TwIH	Int. Request Input High Time	5.5V	5TpC			1,2
10	Twsm	Stop-Mode Recovery Width Spec	5.5V	12		ns	
11	Tost	Oscillator Startup Time	5.5V		5TpC		4
							D1, D0 [Note]
12	Twdt	Watch-Dog Timer Delay Time before time-out	5.5V	3.5		ms	0, 0 [5]
			5.5V	7		ms	0, 1 [5]
			5.5V	14		ms	1, 0 [5]
			5.5V	56		ms	1, 1 [5]
13	T <sub>POR</sub>	Power-On Reset Delay	5.5V	1.5	13	ms	

**Notes::**

1. Timing Reference uses 0.7 V<sub>CC</sub> for a logic 1 and 0.2 V<sub>CC</sub> for a logic 0.
2. Interrupt request via Port 3 (P31–P33).
3. Interrupt request via Port 3 (P30).
4. SMR–D5 = 0.
5. Reg. WDTMR.
6. The V<sub>DD</sub> voltage specification of 5.5V guarantees 5.0V ± 0.5V.
7. Standard Oscillator mode, Pcon RegD7=1.
8. Maximum frequency for external XTAL Clock is 4MHz when using low EMI oscillator mode, Pcon Reg D7=0.

**PIN FUNCTIONS**

$\overline{\text{XTAL1}}$  Crystal 1 (Time-based Input).

$\overline{\text{XTAL2}}$  Crystal 2 (Time-based Output).

$\overline{\text{DPWR}}$  Data Pump Write (Output).

$\overline{\text{DPRESET}}$  Data Pump Reset (Output).

$\overline{\text{DPIRQ}}$  Data Pump Interrupt Request (Input).

$\overline{\text{DPCS}}$  Data Pump Chip Select (Output).

$\overline{\text{DTR}}$  Data Terminal Ready (Input).

$\overline{\text{DCD}}$  Data Carrier Detect (Output).

$\overline{\text{MUTE}}$  Speaker Mute Control (Output).

$\overline{\text{DPRD}}$  Data Pump Read (Output).

$\text{D0–D7}$  DSP Register Data Lines (Input/Output).

$\text{A0–A2}$  DSP Register Address Lines (Output).

$\text{TxD}$  Transmit Data (Output).

$\text{RxD}$  Read Data (Input).

$\overline{\text{OH}}$  Off Hook Relay Output (Output).

$\overline{\text{SHUNT}}$  Pulse Dial Shunt Relay Output (Output).

$\overline{\text{RINGDET}}$  Ring Detect Input (Input).

## AT COMMAND SET

Command lines are typed to the modem from the terminal when the modem is in the Idle or Command state. The modem does not execute any commands from a command line until the command line is ended by the end of line character <CR>. A command line is a string of characters starting with A and T characters and ending with a special end-of-line character, <CR>. Characters typed before the AT are ignored. Command lines contain no more than 40 characters after the AT (not counting spaces). The modem does not execute any commands in a command line that is too long.

To Echo command line characters, use the E1 command.

Typing mistakes can be aborted by using a special Back-Space character, <BS>, after the initial A and T characters are entered.

A partial command line can be aborted by typing a Ctrl-X character. The modem returns an OK result code and ignores the partial AT command line.

Command lines may contain several commands one after another. The ANSWER (A), DIAL (D), and GO ON-LINE (O) commands cause any subsequent commands in the command line to be ignored.

### Command Line Execution

The characters in a command line execute one at a time. Any unexpected characters, except control characters, stop command line execution and return an ERROR result code. Unexpected characters include numbers outside the range of values accepted by the command. All control characters in a command line except Ctrl-X and the special characters such as <CR> and <BS> are ignored.

The numerical argument of a command is assumed to be 0 if not provided. For example, the commands ATH<CR> and ATH0<CR> both hang up the telephone line.

When the modem has executed a command line, the result code of the last command executed is returned to the terminal.

If the value to be written to a modem S-register is outside the range of values accepted by the S-register, then its value is set to the nearest allowed value.

Leading zeros in numeric arguments, including S-register numbers, are ignored. For example, ATS1 is 2 and ATS01 is 2 both set S-register S1 to 2.

All numeric arguments, including S-register numbers, are decimal.

### AT Command Prefix

Each modem command line begins with the letters A and T. The modem uses these characters to determine the data rate and parity of data from the terminal.

### A/ Repeat Last Command

To repeat the commands in the last command line, type the letters A and / instead of A and T.

### <CR>End Of Line Character

This character is typed to end a command line. The value of the <CR> character is stored in S-register S3. The default is 13, the ASCII carriage return character.

When the <CR> character is entered, the modem executes the commands in the command line.

---

**Note:** Default values in Table 2 are denoted by **bold**.

---

Table 2. AT Command Set

Command		Function and Description
A	Answer	<p>The A command causes the modem go off-hook and respond to an incoming call. Uses this command after the modem has returned the RING result code.</p> <p>When modems successfully complete the answering process, they each return a CONNECT result code and enter the On-Line state.</p> <p>If no transmit carrier signal is received from the calling modem within the time specified in S-register S7, the modem hangs up, returns the NO CARRIER result code, and enters the Idle state.</p> <p>Any commands following the answer command on the command line are ignored.</p> <p>This command is aborted if a key is pressed before the answer process is completed, or when DTR is off, if some options in the &amp;Q or &amp;D commands have been used.</p>
B	Communication Standard Option	<p>The B command indicates to the modem which special telephone line modulation standards to use. The modem can be configured to use:</p> <hr/> <p><b>B0</b> Uses the ITU-T modulation standards for all telephone line data rates. This includes V.22 for the 1200 bps telephone line data rate and V.21 for the 300 bps telephone line data rate. If S-register S37 is set to 1 (or 2), then V.23 is used with the originating modem transmitting at 75 bps and receiving at 1200 bps. If S-register S37 is set to any other value, V.23 is not used.</p> <hr/> <p><b>B1</b> If the 1200 bps telephone line data rate is required, Bell 212A is used instead of V.22. This is the default value for North America. The 1200 bps telephone line data rate is required only if:</p> <ul style="list-style-type: none"> <li>• S-register S37 is set to 5, or</li> <li>• S-register S37 is set to 0, and the terminal data rate is 1200 bps.</li> </ul> <p>If the 300 bps telephone line data rate is required, Bell 103 is used instead of V.21. The 300 bps telephone line data rate is required only if:</p> <ul style="list-style-type: none"> <li>• S-register S37 is set to 3, or</li> <li>• S-register S37 is set to 0 and the terminal data rate is 300 bps.</li> </ul> <p>If neither the 1200 bps nor 300 bps telephone line data rate are required, then a setting of B1 is ignored and the modem responds as if B0 was set.</p> <hr/> <p><b>B2</b> Same as B0 for the 1200 bps and 300 bps telephone line date rate. Uses V.23 with the originating modem transmitting at 1200 bps and receiving at 75 bps, if S-register S37 is set to 1 or 2.</p> <hr/> <p><b>B3</b> Same as B0 for the 1200 bps and 300 bps telephone line date rate. Uses V.23 with the originating modem transmitting at 75 bps and receiving at 1200 bps, if S-register S37 is set to 1 or 2.</p>
&C	Data Carrier Detect Options	<p>&amp;C determines how the modem's DCD signal relates to the carrier signal from the other modem. This option occurs only at the beginning of a telephone line connection. If &amp;C is issued from the Command state, it will not have an immediate effect.</p> <hr/> <p><b>&amp;C0</b> During asynchronous operation (&amp;Q0 in effect), DCD is on at all times. During synchronous operation (&amp;Q1), DCD indicates the state of the carrier signal from the other modem using S-registers S9 and S10. This is the default value in North America.</p> <hr/> <p><b>&amp;C1</b> Indicates the state of the carrier signal from the other modem using S-registers S9 and S10.</p>

**Table 2. AT Command Set (Continued)**

Command		Function and Description															
D	Dial	<p>The D command causes the modem to dial a telephone call according to the digits and dial modifiers in the dial string following the command. Any commands following the dial string on a command line are ignored, unless the semicolon dial modifier is the last character in the dial string. If the modem is off-hook when the Dial command is given, the modem dials immediately without trying to detect a dial tone. Characters other than digits and dial modifiers in a dial string are ignored; however, they are counted as characters in the command line buffer.</p> <p>If line current sensing is enabled, and line current is detected before the modem is taken OFF-HOOK when the modem dials, a NO CARRIER result code is displayed and the modem enters the IDLE state. If the modem needs not dial (that is, ATD with no dial string), the modem assumes the call was manually established and attempts to make a connection.</p> <p>The D command is not valid when the modem is in the On-Line state. See “Dial Modifiers and “Modem Result Codes for more information.</p>															
&D	Data Terminal Ready Options	<p>&amp;D determines how the modem responds to the DTR signal from the terminal. The country configuration may prevent the modem from detecting terminal DTR. In this case, the modem assumes DTR is always on. In North America, terminal DTR is normally detected. If DTR detection has been prevented, the modem will respond with an ERROR result to this command.</p> <p>The response to changes in DTR also depends on the &amp;Q and &amp;D commands. This table defines what happens when DTR goes off for all possible combinations of the &amp;D and &amp;Q commands. To see what happens when DTR goes on, refer to the &amp;Q command. The default value is &amp;D0 in North America:</p> <table border="1"> <thead> <tr> <th></th> <th>&amp;D0</th> <th>&amp;D1</th> <th>&amp;D2</th> <th>&amp;D3</th> </tr> </thead> <tbody> <tr> <td>&amp;Q0</td> <td>None</td> <td>B</td> <td>C</td> <td>D</td> </tr> <tr> <td>&amp;Q1</td> <td>A</td> <td>B</td> <td>C</td> <td>D</td> </tr> </tbody> </table> <p>A The modem hangs up the telephone line and issues an OK result code.</p> <p>B If in the On-Line state, the modem goes into the Command state, and issues an OK result code.</p> <p>C The modem hangs up the telephone line and issues an OK result code. Auto-Answer is disabled as long as DTR stays off.</p> <p>D The modem resets.</p>		&D0	&D1	&D2	&D3	&Q0	None	B	C	D	&Q1	A	B	C	D
	&D0	&D1	&D2	&D3													
&Q0	None	B	C	D													
&Q1	A	B	C	D													

Table 2. AT Command Set (Continued)

Command		Function and Description
E	Command Mode Character Echo	E tells the modem to echo or not echo characters sent from the terminal while the modem is accepting AT commands.
		E0 Does not echo characters sent from the terminal.
		E1 Echo characters sent from the terminal. This is the default value in North America.
%E	Automatic Retrain Options	The %E command controls whether the modem will initiate retrain with the other modem during a telephone line connection during operation in data modes supporting retrain. The modem always responds to a retrain operation initiated by the remote modem. The modem can be forced to initiate a retrain by the On-Line (O1) command.
		%E0 Do not initiate a retrain.
		%E1 Initiate a retrain if the datapump indicates that one is required.
&F	Recall Factory Profile	&F changes these AT command options and S-registers to default values. The default values may be changed for use in different countries. The values for North America are:
		S-registers
		S0=0 S1=0 S2=43 S3=13 S4=10 S5=8
		S6=2 S7=30 S8=2 S9=6 S10=14 S11=95
		S12=50 S17=10 S25=5 S28=0 S29=25 S37=0
		Commands
		B1 E1 M1 P Q0 V1 X4 &C0 &D0 &G0 &P0 &Q0 %E1
&G	Guard Tone Options	&G indicates the modem which guard tone to transmit when the modem is transmitting the high band (that is, answer handshake and answer mode).
		&G0 No guard tone. This is the default value in North America.
		&G1 550-Hz guard tone (V.22 and V.22bis only)
		&G2 1800-Hz guard tone (V.22 and V.22bis only)
H	Hook	H0 Hangs up the telephone line.
		H1 Goes off hook without answering a telephone call. This may be disabled in countries prohibiting its use.

**Table 2. AT Command Set (Continued)**

Command		Function and Description
&HT	PTT Test Command	The &HT command causes the modem to transmit tones for PTT testing. The test tone is generated until a character is typed on the modem's terminal. The country configuration may disable this command. The modem returns an ERROR result if this command is issued.
&HT0-9		DTMF tone for digit n where the command was &HTn.
&HT10		DTMF tone "*"
&HT11		DTMF tone "#"
&HT12		DTMF tone "A"
&HT13		DTMF tone "B"
&HT14		DTMF tone "C"
&HT15		DTMF tone "D"
&HT16		V.21 channel 1 mark
&HT17		V.21 channel 2 marks
&HT18		V.23 1200bps marks
&HT19		V.23 75bps marks
&HT20		V.21 channel 1 spaces
&HT21		V.21 channel 2 spaces
&HT22		V.23 1200bps spaces
&HT23		V.23 75bps spaces
&HT24		V.22 originate mode
&HT25		V.22 answer mode
&HT26		V.22bis originate mode
&HT27		V.22bis answer mode
&HT28		V.25 calling tone
&HT29		550Hz guard tone
&HT30		1800Hz guard tone
&HT31		Silence
&HT32		Detect 2100 Hz answer tone
&HT33		Detect all supported answer tones simultaneously
&HT34		Detect dial tone
&HT35		Detect call progress tones
I	Identification	The I command queries the modem for information that can be used to determine the modem's compatibility with other software and to ensure the modem is operating properly.
	I0	Displays product code. The modem reports its product code to the terminal. The modem produces information text dependent upon its features and capabilities.
	I1	Displays ROM checksum. The modem reports the value of its ROM checksum. The decimal number displayed is the eight bit sum (from 0 to 255) of all the bytes in ROM.
	I2	Tests the ROM checksum. The modem checks its ROM to ensure it is correct. The modem reports a result code indicating whether the ROM is OK or in ERROR.
	I3	Displays Software Versions. The modem reports the modem controller and data pump software versions, and the modem controller software release date, to the terminal.
	I4	Displays Modem Identification. The modem reports a configured identification message to the terminal.

Table 2. AT Command Set (Continued)

Command	Function and Description
M	Speaker On/Off Options
	The country configuration may disable the speaker. If so, this command returns an ERROR result.
	M0 Speaker always off.
	M1 Speaker on until carrier detected. This is the default value in North America.
	M2 Speaker always on; stays on after carrier is detected.
	M3 Speaker off as digits are dialed, but on during ringback and on until carrier signal is detected.
O	Return to On-Line Mode
	This command returns the modem to the on-line mode. It is frequently used after the escape character sequence (+++) to resume communication with the remote modem. If handshaking is started, the modem uses Originate or Answer mode handshaking, depending upon whether the modem originated or answered the telephone call.
	O0 Returns the modem to the On-Line state from the Command state during a telephone line connection. The modem starts handshaking if no telephone line connection and the modem was off hook.
	O1 Returns the modem to the On-Line state and retrain its data pump during a telephone line connection. The modem starts handshaking if there was no telephone line connection is detected but the modem was OFF-HOOK.
&P	Pulse Dial Make/Break Ratios
	Sets cadence of pulse dial. The country configuration may disable this command, forcing particular pulse dialing parameters. In this event, the modem returns an ERROR result if this command is issued.
	&P0 39%/61% make/break ratio and 10 pulses per second when pulse dialing. This is the default value.
	&P1 33%/67% make/break ratio and 10 pulses per second when pulse dialing.
	&P2 39%/61% make/break ratio and 20 pulses per second when pulse dialing.
	&P3 33%/67% make/break ratio and 20 pulses per second when pulse dialing.
Q	Result Code Display Options
	This command allows the user to either display result codes or to not display result codes.
	Q0 Result codes are displayed. This is the default value for North America.
	Q1 Result codes are not displayed.
&Q	Communications Mode Options
	The &Q command selects the terminal communication mode.
	&Q0 Asynchronous. The modem handshakes as the originator if S-register S0 is 0, and as the answerer if S0 is 1. This is the default value for North America.
	&Q1 Synchronous. Hangs up if DTR goes from on to off after the time in S-register S25 after the CONNECT result code has been sent to the terminal.
Sn	Set the current S-register to n
	This command sets the current S-register to the value <i>n</i> selected by the user. For example, AT\$7 will set the current S-register to S7. Default value is 0. Sn addresses a particular S-register number so future commands like ? and = will read of write the S-register. Modem reset and the &F command select S0 as the default S-register.
?	Read an S-Register
	This command displays the value of the last S-register named in the Sn command.
=x	Write an S-register
	This command writes the value x to the last S-register named in the Sn command. The range of valid values for x depends upon which S-register is being written. 0 is assumed if no value is given for x.
T	Tone dialing
	Selects the tone method of dialing.
V	Result Code Format
	This command changes the result code display format
	V0 All result codes are displayed as numbers.
	V1 All result codes are displayed as words (verbose form). This is the default value for North America.

**Table 2. AT Command Set (Continued)**

Command	Function and Description
X Call Progress	The X command controls whether or not a busy signal or dial tone is detected when dialing. The X command also limits the result codes the modem returns when dialing. The operation of the X command is configurable for operation in different countries.
X0	Neither busy signal nor dial tone are detected. When a telephone line connection is made, the result code does not indicate the telephone line data rate.
X1	Neither busy signal nor dial tone are detected. When a telephone line connection is made, the result code indicates the telephone line data rate.
X2	Busy signal is not detected. Dial tone is detected. When a telephone line connection is made, the result code indicates the telephone line data rate.
X3	Busy signal is detected. Dial tone is not detected. When a telephone line connection is made, the result code indicates the telephone line data rate.
X4	Both busy signal and dial tone are detected. When a telephone line connection is made, the result code indicates the telephone line data rate. This is the default value in North America.
The @ and W dial modifiers are not affected by the X command. The @ dial modifier may return the result codes 8 (NO ANSWER) or 7 (BUSY) each time it appears in the dial string. The W dial modifier may return the result codes 6 (NO DIALTONE) or 7 (BUSY) each time it appears in the dial string.	
#CID= Caller Id Options	The #CID= command controls how the modem displays North American caller identification information. The #CID= command is valid only if the Modem Controller software has been compiled to support Caller ID. If the software has not been compiled to support Caller ID then the modem responds with an ERROR result code to a #CID= command. Caller Id information is displayed only when it is provided by the telephone company, and only when the terminal data rate is 2400 bps. Lower data rates are too slow to display the Caller Id information.
#CID=0	Do not display caller identification information. This is the default value.
#CID=1	Display the information in as formatted data.
#CID=2	Display the information as unformatted data.
#CID=?	Display the current setting of the #CID= command option.

**DIAL MODIFIERS**

Dial modifiers perform special functions within a dial command.

---

**Example:** ATDT9W1552368!@#71234;<CR>

---

The example instructs the modem to use tone dialing (T), to access a number outside a PBX (9), to wait for dial tone (W), to dial the number 1552368, to do a hook-flash (i.e. timed break recall), to wait for quiet answer, and to issue the PBX transfer code #7 before dialing extension number 1234, then to return to the Command state before initiating the handshake.

**Table 3. Dial Modifiers**

<b>Modifier</b>	<b>Function</b>
0-9 A B C D # *	Dialing digits and characters. The digits and characters 0-9 A B C D # * specify what numbers the modem dials. The characters A B C D # * work only when tone dialing is used. The characters are ignored when pulse dialing is used. The characters A, B, C, and D may be disabled in countries prohibiting their use.
P	Pulse dialing. P selects the pulse method of dialing. P can be issued within a dial command or as a separate command. The default method of dialing is Pulse.
R	Originates a Call in Answer Mode. R makes the modem handshake in answer mode so it can originate a call to an originate-only modem.
T	Tone dialing. T selects the tone method of dialing. T can be issued within a dial command or as a separate command. The default method of dialing is Pulse.
W	Waits for dial tone. W makes the modem wait for a dial tone before proceeding. If no dial tone is detected the modem hangs up the telephone line and returns the NO DIALTONE result code.
,	Delays Processing of Next Character. A comma (,) makes the modem pause for the length of time in S-register S8 before processing the next character in a dial string.
@	Waits for Quiet Answer. @ makes the modem listen for 5 seconds of silence before continuing. The modem will wait up to the length of time in S-register S7. If 5 seconds (configurable by country) of silence are not detected within the time period in S-register S7, the modem hangs up and returns the NO ANSWER result code. If 5 seconds of silence are detected, the modem continues processing the other characters in the dial string.
!	Timed Break Recall (Hookflash). A ! makes the modem hang up the telephone line for the length of time in S-register S29, then take the telephone line off hook again. This is frequently used to access a PBX's call transfer function.
;	Returns to Command State after dialing. A semicolon (;) tells the modem to return to command state after dialing without breaking the telephone line connection and without handshaking with the other modem. The semicolon may only be used when calling a voice mail system that permits tones to transmit numbers when a connection has been established.

## MODEM S-REGISTERS

The value of an S-register is modified by  $ATSn = x$ , where n is the register number and x is the value to be stored in that particular register. Each S-register has three values that may be configured for different countries: a default value, an upper limit, and a lower limit. The values shown in this manual are for North America.

**Table 4. Modem S-Registers**

Register	Range	Units	Description
S0	0–255	Rings	Sets number of rings to auto-answer. The country configuration may disable the modem's ability to detect a telephone line ring signal. In this case, the modem will never automatically answer the telephone regardless of the S0 setting. Default = 0 (auto-answer disabled)
S1	0–255	Rings	Returns the number of times the phone rings. Default = 0
S2	0–255	ASCII	Sets Escape Sequence Character. Setting S2 to a value greater than 127 disables the character escape sequence, preventing the modem from returning to Command state when in the On-Line state. Default = 43
S3	0–127	ASCII	Sets the End of Line character. Default = 13
S4	0–127	ASCII	Sets the Line Feed Character. Default = 10
S5	0–127	ASCII	Sets the BackSpace Character. Default = 8
S6	2–255	Seconds	Delays to Wait Before Performing a Blind Dial. Default = 2 seconds
S7	1–255	Seconds	Delays to Wait for Carrier after dialing. Default = 30 seconds
S8	0–255	Seconds	Delays to Wait when a Comma Dial Modifier is Processed. Default = 2 sec.
S9	1–255	1/10th sec	Time Carrier Must be Present Before Being Recognized. Default = 0.6 sec.
S10	1–255	1/10th sec	Delay Between Lost Carrier and Hang Up. Setting S-register S10 to 255 prevents the modem hanging up the telephone line because of a loss of carrier. Default = 14 tenths of a second
S11	50–255	msec	Multi-Frequency Tone duration. Default = 95 milliseconds
S12	0–255	1/50th sec	Escapes Prompt delay time. This is the prompt delay time for escape sequences from the On-Line state to the Command state. Default = 50 fiftieths of a second
S13	Reserved	Reserved	Reserved
S14	Reserved	Reserved	Reserved
S15	Reserved	Reserved	Reserved
S16	Reserved	Reserved	Reserved
S17	–6 to –43	–dBm	Sets Transmit level. Default = –10 dBm
S18	Reserved	Reserved	Reserved
S19	Reserved	Reserved	Reserved
S20	Reserved	Reserved	Reserved

Table 4. Modem S-Registers (Continued)

Register	Range	Units	Description
S21	Reserved	Reserved	Reserved
S22	Reserved	Reserved	Reserved
S23	Reserved	Reserved	Reserved
S24	Reserved	Reserved	Reserved
S25	0–255	seconds or 1/100 sec.	During synchronous operation with the &Q1 command in effect, S-register S25 indicates the number of seconds after a telephone line connection is made before the modem examines DTR. This register allows sufficient time to disconnect the modem from an asynchronous terminal and attach it to a synchronous terminal. In the On-Line or Command state during any mode of operation, changes in DTR for less than S25 hundredths of a second are ignored.
S26	Reserved	Reserved	Reserved
S27	Reserved	Reserved	Reserved
S28	0–255	minutes	Terminal inactivity timeout. Hangs up the modem after S28 minutes if no characters are received from the modem's terminal. Default = 0
S29	0–255	1/50th sec	Hook Flash On-Hook time. The amount of time in 20 millisecond units the modem will leave the telephone on-hook while performing a hook-flash according to the "!" dial string modifier. Default = 25 fiftieths of a second.
S37	0–6	code	Sets the Highest Line Rate. This register determines the highest telephone line data rate the modem will use when connecting with a remote modem. See "Setting the Highest Line Rate" section on the following page. Default = 0.

## SETTING THE HIGHEST LINE RATE

The connect rate can be selected by S-register S37. The following connect rates are supported.

**Table 5. S-Register 37 Values**

<b>S37 Value</b>	<b>Carrier</b>	<b>Data Rate</b>
0		The data rate of the last AT command
1	V.23	Refer to the Communication Standard Options (B) command for a description.
2	V.23	See immediately above.
3	V.21, Bell 103	300 bps. See the B command
4		Reserved
5	V.22, Bell 212A	1200 bps. See the B command
6	V.22bis	2400 bps

**MODEM RESULT CODES**

A result code is a line of text or a number the modem sends to the terminal indicating the result of a command execution. Some CONNECT result codes indicate the telephone line data rate. The following table provides a list of the available result codes.

**Table 6. Modem Result Codes**

<b>Number</b>	<b>Word</b>	<b>Result Code Description</b>
0	OK	Command Line Executed without errors
1	CONNECT	The modem is in the on-line state, ready to transfer data.
2	RING	The modem has detected a ring signal on the telephone line. The country configuration may disable the modem's ability to detect a telephone line ring signal.
3	NO CARRIER	Either no carrier signal was detected when answering or placing a telephone call, or the carrier was lost during a call. The modem also returns this response message when the telephone line connection is broken for any reason.
4	ERROR	An invalid command was issued, or there was an error at any place in the command line.
5	CONNECT 1200	The modem is in the on-line state, ready to transfer data.
6	NO DIALTONE	No dial tone was detected when the modem took the telephone line off hook.
7	BUSY	The modem detected a busy signal on the telephone line.
8	NO ANSWER	Not enough silence was detected when the @ dial modifier was used.
10	CONNECT 2400	The modem is in the on-line state, ready to transfer data. The telephone line data rate is 2400bps.
16	CONNECT 1200/75	The modem is in the On-Line state, ready to transfer data. This modem transmits at 1200 bps and receives at 75 bps.
17	CONNECT 75/1200	The modem is in the On-Line state, ready to transfer data. This modem transmits at 75 bps and receives at 1200 bps.
20	BLACKLISTED	The modem will not allow any number to be dialed until after the modem is reset.
21	DELAYED	The modem will not allow any number to be dialed now, but will allow dialing at some future time.

---

## ESCAPE SEQUENCES

An escape sequence is defined as one or more particular characters sent from the terminal to the modem during the On-Line state. This sequence is activated to switch the modem to the command state so modem commands may be entered during a telephone line connection. The Escape Sequence characters are typically sent to the other modem as data.

An escape sequence should not occur accidentally during an exchange of data between two modems. Unfortunately, it is impossible to guarantee that any escape sequence will never occur naturally, because there are no restrictions on the data or timing between characters sent between two modems during the On-Line state.

The only method of switching from the On-Line state to the Command state that never occurs naturally during an exchange of data is the Data Terminal Ready signal (the &D1 command). The terminal has complete control of this signal and it is not part of the data exchanged between the modems.

The Hayes Escape Sequence was adopted by many modem manufacturers and communication programs before Hayes was granted a patent for the escape sequence guard times. Now the unpatented TIME INDEPENDENT ESCAPE SEQUENCE (TIES) has gained popularity with many modem manufacturers.

### TIES Escape Sequence

TIES was developed by a number of modem manufacturers in response to Hayes enforcing patent rights for their escape sequence guard time patent.

The Time Independent Escape Sequence, is a sequence of 3 escape characters (+ characters by default). When these characters are recognized, the modem enters the COMMAND state without sending a confirming result code to the terminal. The modem then starts a prompt delay timer. From that point:

- If one of the recognized AT commands is received before the timer expires, the timer is stopped, the command is executed, and its result code is sent to the terminal.
- If any other data is received while the timer is running, the timer is stopped, the modem returns to the On-Line state, and the received data is sent to the other modem.
- If the timer expires, a confirming result code is sent to the terminal, indicating the modem is in the Command state.

The escape character and prompt delay timer can be changed by writing new values to S-registers S2 and S12.

---

## CARRIER DETECTION

After Handshaking, the modem determines if a telephone line connection exists by detecting the carrier signal from the other modem. If the carrier is not detected for a long enough period of time, the modem assumes the telephone line connection with the other modem has been broken. The

modem uses S-register S9 to determine how long a carrier must be present before it is *detected*. The modem uses S-register S10 to determine how long a carrier is not detected before the telephone line is hung up.

---

## BLACKLISTING MANAGEMENT

Blacklisting applies separately to each number dialed, and indicates the call blocking capability for specific phone numbers. To save Z02205 RAM, calls are treated as if they are all to the same number.

The first connection attempt after modem reset or a successful connection is always allowed. If a connection attempt is not successful, then each following connection attempt is checked as follows:

1. If voice answer was detected too many times the attempt is not allowed, *Modem Result Code* indicates the call is BLACKLISTED.

2. If the attempt occurred too quickly (within the inter-call timing period) then the attempt is not allowed, *Modem Result Code* indicates the call is DELAYED.
3. If there is a blacklisting period limiting the number of attempts that may be made within the period, and too many attempts have been made, then the attempt is not allowed, *Modem Result Code* indicates the call is either DELAYED (if a call may be made later), or BLACKLISTED (if no call may be made later).

The following blacklisting parameters can be controlled:

- Minimum delay in seconds between successive dial attempts
- Number of successive dial attempts after which the following parameter applies
- Minimum delay in seconds between successive dial attempts after
- Unsuccessful dial attempts
- Maximum number of dial attempts permitted in a series of dial attempts
- Blacklisting period in minutes for each series of dial attempts

---

## DYNAMIC POWER MANAGEMENT

The Z02205 incorporates a low-power SLEEP mode. In this mode, the clock is shut down (effectively stopping the part).

The Modem Controller software automatically puts the modem's data pump into a power-saving SLEEP mode when it is not used and there is no connection. The Modem Controller software also puts the Modem Controller to sleep when possible. This power-saving feature reduces the amount of current used by 8 mA.

This sleep feature operates transparently to the modem's operation, saving approximately 58 mA of power when both the modem data pump and controller are put into sleep mode.

The modem controller goes to sleep under following conditions:

- Looking for an 'A' (Auto Baud)
- The ring line has been debounced

- The RINGS register has been cleared
- There are no incoming characters
- There are no characters in the input queue
- The Modem Controller is put to sleep until there is an interrupt, such as:
  - A start bit from the terminal.
  - Telephone line ring detection from the telephone line interface.

In SLEEP mode, the modem controller turns off the main timer interrupt and turns on the ring detect interrupt, leaves the start bit interrupt running - then halts until an interrupt occurs.

The Modem Controller cannot sleep if dial blacklisting has been enabled in the country parameters and is being timed. Nor can the Modem Controller sleep if AT and D3 is set because a DTR On-to-Off transition can not wake it up

---

## FUNCTIONAL DESCRIPTION

**Clock.** The Z02205 on-chip oscillator has a high-gain, parallel-resonant amplifier for connection to a crystal (XTAL1 is Input, XTAL2 is Output). The crystal should be AT cut, 16 MHz max., with a series resistance (RS) of less than or equal to 100 Ohms when counting from 1 MHz to 16 MHz.

Connect the crystal across XTAL1 and XTAL2 using the vendor's recommended capacitor values from each pin directly to the device GROUND pin to reduce Ground noise injection into the oscillator.

---

**Note:** For better noise suppression, the capacitors must be tied directly to the device Ground pin ( $V_{SS}$ ).

---

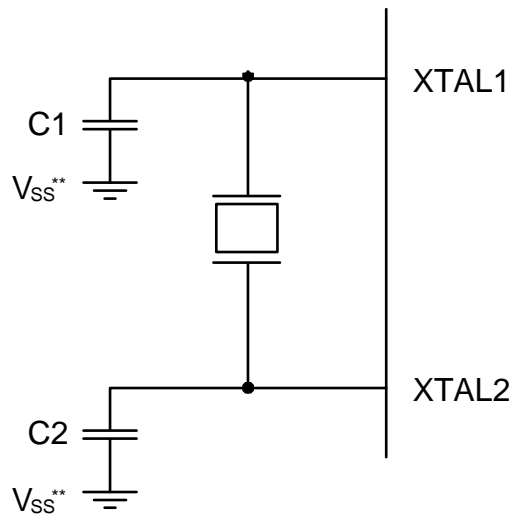

Ceramic Resonator or Crystal

C1, C2 = 22 pF TYP\*

f = 8 MHz

\*Preliminary value including pin parasitics

\*\*Device ground pin

**Figure 5. Oscillator Configuration**

**Power-On-Reset (POR).** A timer circuit, clocked by a dedicated on-board RC oscillator, is used for the POWER-ON RESET (POR) timer function. The POR time allows  $V_{CC}$  and the oscillator circuit to stabilize before instruction execution begins.

The POR timer circuit is a one-shot timer triggered by one of four conditions:

- Power fail to Power OK status.
- STOP-MODE RECOVERY (if bit D5 of SMR is set to 1).
- WDT time-out.
- The POR time is specified as TPOR.



PACKAGE INFORMATION

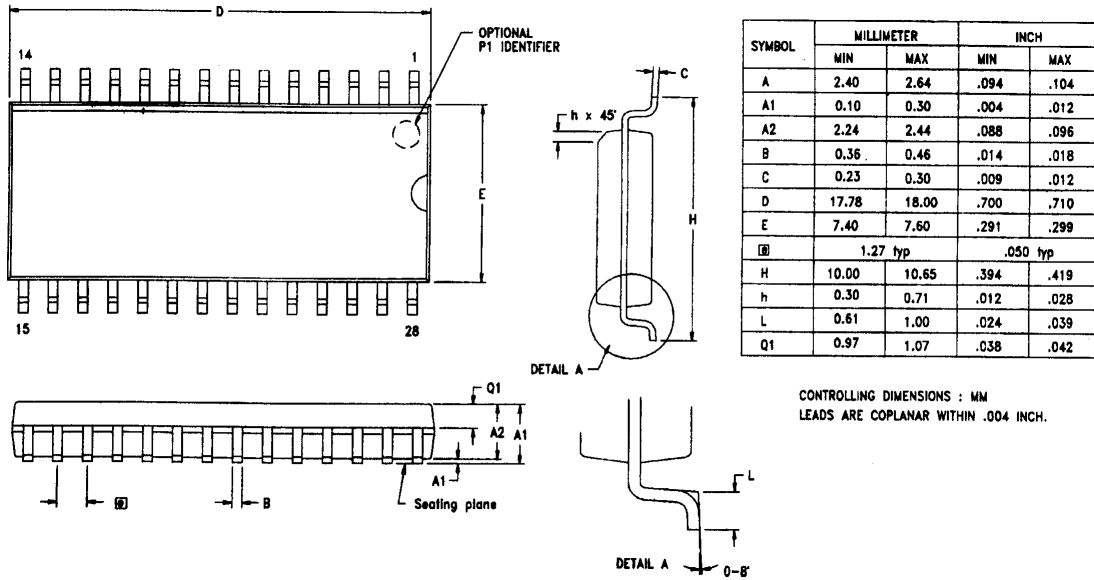

Figure 7. 28-pin SOIC Package Diagram

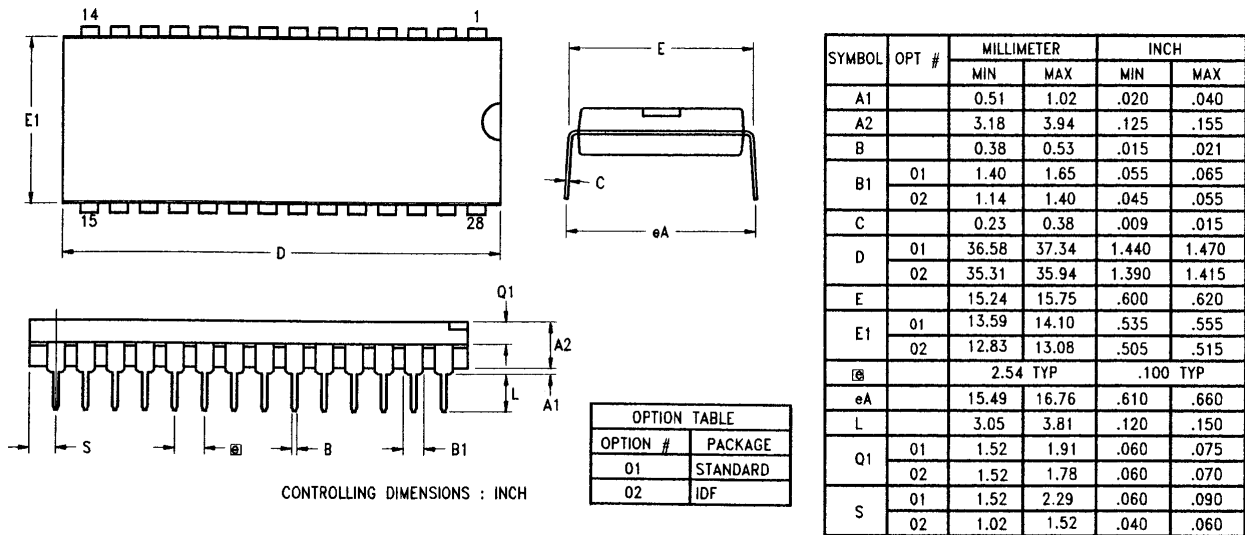

Figure 8. 28-pin DIP Package Diagram

**ORDERING INFORMATION**

<b>28-Pin SOIC</b>	Z0220516SSCR4292 Z0220516SSCR4259 Z0220516SSCR3641 Z0220516SSC1961
<b>28-Pin DIP</b>	Z0220516PSCR4292 Z0220516PSCR4259 Z0220516PSCR3641 Z0220516PSC1961

**Codes**

Package	S = Small Outline Integrated Chip (SOIC) P = Plastic DIP
Standard Temperature	S = 0°C to +70°C
Speed	16 = 16 MHz
Environmental	C = Plastic Standard
ROM Code	R4292 = ROM code number 4292 (ROM code Version 3.4) R4259 = ROM code number 4259 (ROM code Version 3.4) R3641 = ROM code number 3641 (ROM code Version 3.0) 1961 suffix = Blank Device; One Time Programmable (OTP)

**Z02205 Compatibility Matrix for ZiLOG data pumps**

ZiLOG recommends use of latest modem data pumps.

	<b>Z02201 Code Version 0x31 ROM Code #R3470</b>	<b>Z02201 Code Version 0x48 ROM Code #4078</b>	<b>Z02922 Code Version 0x3A ROM Code #R3796</b>	<b>Z02922 Code Version 0x42 ROM Code #R3910</b>
<b>Z02205 Ver 3.0</b>	Z02205 ROM #R3641			
<b>Z02205 Ver 3.4</b>	Z02205 ROM #R4259	Z02205 ROM #R4292		

**Example**

Z 02205 16 S S C R4259

is a Ver. 3.4 (R4259) Z02205 compatible with Ver. 31 (R3470) of Z02201, 16 MHz, PLCC, 0°C to +70°C, Plastic Standard Flow

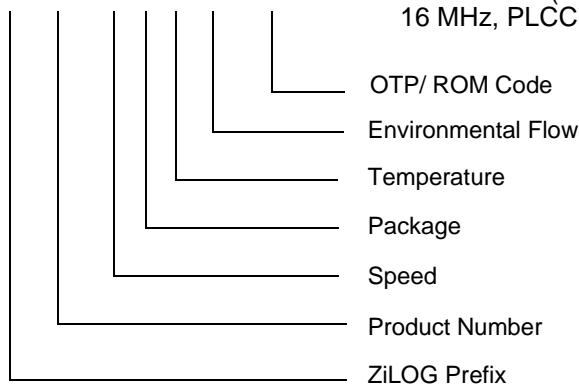

---

### Pre-Characterization Product:

The product represented by this product brief is newly introduced and ZiLOG has not completed the full characterization of the product. The CPS states what ZiLOG knows about this product at this time, but additional features or non-conformance with some aspects

of the product brief may be found, either by ZiLOG or its customers in the course of further application and characterization work. In addition, ZiLOG cautions that delivery may be uncertain at times, due to start-up yield issues.

---

### Low Margin:

Customer is advised that this product does not meet ZiLOG's internal guardbanded test policies for the specification requested and is supplied on an exception basis. Customer is cautioned that delivery may be uncertain and that, in addition to all other limitations on

ZiLOG liability stated on the front and back of the acknowledgment, ZiLOG makes no claim as to quality and reliability under the product brief. The product remains subject to standard warranty for replacement due to defects in materials and workmanship.

---

© 1998 by ZiLOG, Inc. All rights reserved. No part of this document may be copied or reproduced in any form or by any means without the prior written consent of ZiLOG, Inc. The information in this document is subject to change without notice. Devices sold by ZiLOG, Inc. are covered by warranty and patent indemnification provisions appearing in ZiLOG, Inc. Terms and Conditions of Sale only.

ZILOG, INC. MAKES NO WARRANTY, EXPRESS, STATUTORY, IMPLIED OR BY DESCRIPTION, REGARDING THE INFORMATION SET FORTH HEREIN OR REGARDING THE FREEDOM OF THE DESCRIBED DEVICES FROM INTELLECTUAL PROPERTY INFRINGEMENT. ZILOG, INC. MAKES NO WARRANTY OF MERCHANTABILITY OR FITNESS FOR ANY PURPOSE.

ZiLOG, Inc. shall not be responsible for any errors that may appear in this document. ZiLOG, Inc. makes no commitment to update or keep current the information contained in this document.

ZiLOG's products are not authorized for use as critical components in life support devices or systems unless a specific written agreement pertaining to such intended use is executed between the customer and ZiLOG prior to use. Life support devices or systems are those which are intended for surgical implantation into the body, or which sustains life whose failure to perform, when properly used in accordance with instructions for use provided in the labeling, can be reasonably expected to result in significant injury to the user.

ZiLOG, Inc.  
910 East Hamilton Avenue, Suite 110  
Campbell, CA 95008  
Telephone (408) 558-8500  
FAX 408 558-8300  
Internet: <http://www.zilog.com>

## Looking for pricing, stock, or lifecycle information?

Click below to explore more details on WIN SOURCE:

 [View Z0220516SSGR3641 on WIN SOURCE](#)

 [Zilog Information](#)

## Optimize Your Supply Chain with WIN SOURCE Solutions

-  Global Sourcing Solution
-  Obsolete Management
-  Cost Control Management
-  Shortage Management
-  Alternative Solution
-  Excess Inventory Management