



**THE DATASHEET OF  
LTC4227IGN-2#PBF**



# Dual Ideal Diode and Single Hot Swap Controller

## FEATURES

- Power Path and Inrush Current Control for Redundant Supplies
- Low Loss Replacement for Power Schottky Diodes
- Allows Safe Hot Swapping from a Live Backplane
- 2.9V to 18V Operating Range
- Controls N-Channel MOSFETs
- Limits Peak Fault Current in  $\leq 1\mu\text{s}$
- 0.5 $\mu\text{s}$  Ideal Diode Turn-On and Reverse Turn-Off Time
- Adjustable Current Limit with Circuit Breaker
- Smooth Switchover without Oscillation
- Adjustable Current Limit Fault Delay
- Fault and Power Status Output
- 20-Lead 4mm  $\times$  5mm QFN and 16-Lead SSOP Packages

## APPLICATIONS

- Redundant Power Supplies and Supply Holdup
- Computer Systems and Servers
- Telecom Networks

LT, LT, LTC, LTM, Linear Technology and the Linear logo are registered trademarks of Linear Technology Corporation. Hot Swap is a trademark of Linear Technology Corporation. All other trademarks are the property of their respective owners.

## DESCRIPTION

The LTC<sup>®</sup>4227 offers ideal diode-OR and Hot Swap<sup>™</sup> functions for two power rails by controlling external N-channel MOSFETs. MOSFETs acting as ideal diodes replace two high power Schottky diodes and the associated heat sinks, saving power and board area. A Hot Swap control MOSFET allows a board to be safely inserted and removed from a live backplane by limiting inrush current. The supply output is also protected against short-circuit faults with a fast acting current limit and internal timed circuit breaker.

The LTC4227 regulates the forward voltage drop across the MOSFETs to ensure smooth current transfer from one supply to the other without oscillation. The ideal diodes turn on quickly to reduce the load voltage droop during supply switchover. If the input supply fails or is shorted, a fast turn-off minimizes reverse-current transients.

The LTC4227 allows turn-on/off control, and reports fault and power good status for the supply.

PART	OVERCURRENT FAULT	START-UP DELAY
LTC4227-1	LATCH OFF	100ms
LTC4227-2	RETRY	100ms
LTC4227-3	LATCH OFF	1.6ms
LTC4227-4	RETRY	1.6ms

## TYPICAL APPLICATION

Diode-OR with Hot Swap Application

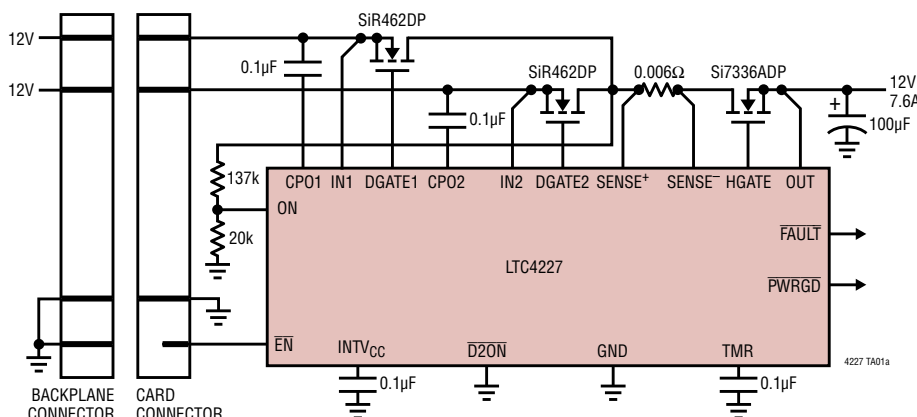

Smooth Supply Switchover

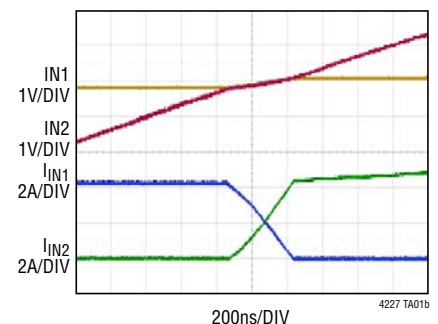

# LTC4227

## ABSOLUTE MAXIMUM RATINGS (Notes 1, 2)

Supply Voltages		HGATE (Note 4) .....	-0.3V to 35V
IN1, IN2.....	-0.3V to 24V	OUT .....	-0.3V to 24V
INTV <sub>CC</sub> .....	-0.3V to 7V	Average Currents	
Input Voltages		FAULT, PWRGD .....	5mA
ON, EN, D2ON .....	-0.3V to 24V	INTV <sub>CC</sub> .....	1mA
TMR.....	-0.3V to INTV <sub>CC</sub> + 0.3V	Operating Temperature Range	
SENSE <sup>+</sup> , SENSE <sup>-</sup> .....	-0.3V to 24V	LTC4227C .....	0°C to 70°C
Output Voltages		LTC4227I .....	-40°C to 85°C
FAULT, PWRGD .....	-0.3V to 24V	Storage Temperature Range .....	-65°C to 150°C
CPO1, CPO2 (Note 3) .....	-0.3V to 35V	Lead Temperature (Soldering, 10 sec)	
DGATE1, DGATE2 (Note 3).....	-0.3V to 35V	GN Package .....	300°C

## PIN CONFIGURATION

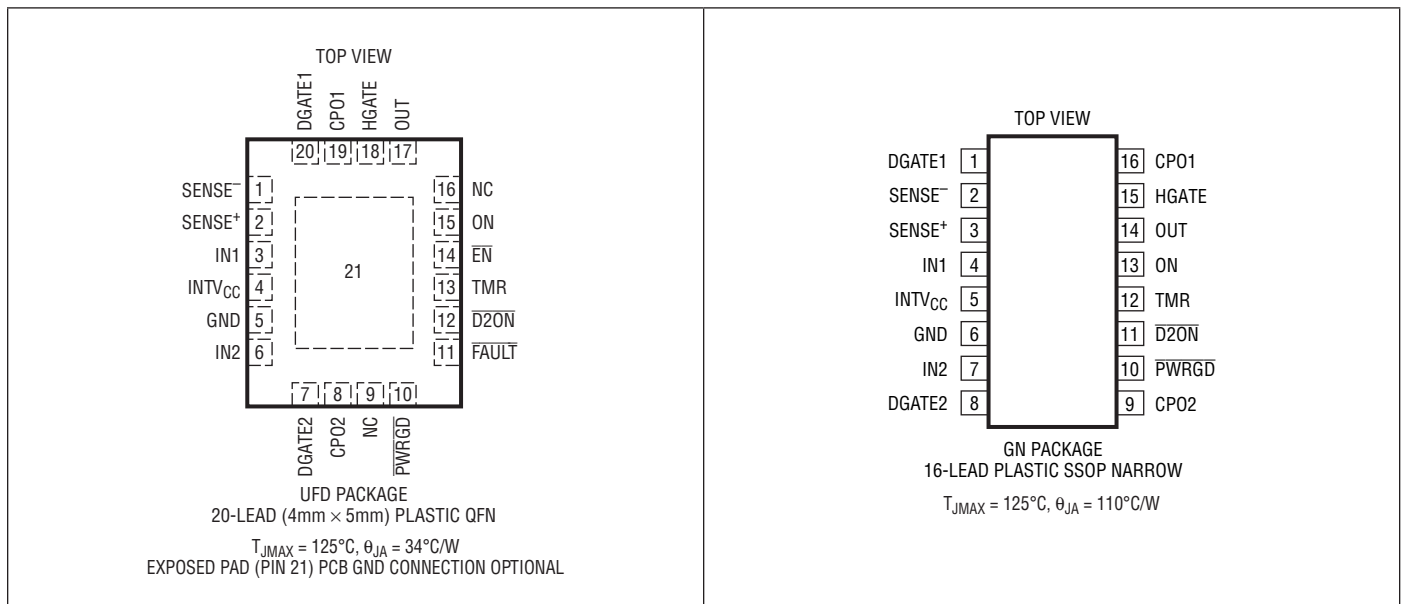

## ORDER INFORMATION

LEAD FREE FINISH	TAPE AND REEL	PART MARKING*	PACKAGE DESCRIPTION	TEMPERATURE RANGE
LTC4227CUFD-1#PBF	LTC4227CUFD-1#TRPBF	42271	20-Lead (4mm × 5mm) Plastic QFN	0°C to 70°C
LTC4227CUFD-2#PBF	LTC4227CUFD-2#TRPBF	42272	20-Lead (4mm × 5mm) Plastic QFN	0°C to 70°C
LTC4227CUFD-3#PBF	LTC4227CUFD-3#TRPBF	42273	20-Lead (4mm × 5mm) Plastic QFN	0°C to 70°C
LTC4227CUFD-4#PBF	LTC4227CUFD-4#TRPBF	42274	20-Lead (4mm × 5mm) Plastic QFN	0°C to 70°C
LTC4227IUF-1#PBF	LTC4227IUF-1#TRPBF	42271	20-Lead (4mm × 5mm) Plastic QFN	-40°C to 85°C
LTC4227IUF-2#PBF	LTC4227IUF-2#TRPBF	42272	20-Lead (4mm × 5mm) Plastic QFN	-40°C to 85°C
LTC4227IUF-3#PBF	LTC4227IUF-3#TRPBF	42273	20-Lead (4mm × 5mm) Plastic QFN	-40°C to 85°C
LTC4227IUF-4#PBF	LTC4227IUF-4#TRPBF	42274	20-Lead (4mm × 5mm) Plastic QFN	-40°C to 85°C
LTC4227CGN-1#PBF	LTC4227CGN-1#TRPBF	42271	16-Lead Plastic SSOP	0°C to 70°C
LTC4227CGN-2#PBF	LTC4227CGN-2#TRPBF	42272	16-Lead Plastic SSOP	0°C to 70°C
LTC4227IGN-1#PBF	LTC4227IGN-1#TRPBF	42271	16-Lead Plastic SSOP	-40°C to 85°C
LTC4227IGN-2#PBF	LTC4227IGN-2#TRPBF	42272	16-Lead Plastic SSOP	-40°C to 85°C

Consult LTC Marketing for parts specified with wider operating temperature ranges. \*The temperature grade is identified by a label on the shipping container. Consult LTC Marketing for information on nonstandard lead based finish parts.

For more information on lead free part marking, go to: <http://www.linear.com/leadfree/>

For more information on tape and reel specifications, go to: <http://www.linear.com/tapeandreel/>

## ELECTRICAL CHARACTERISTICS

The ● denotes the specifications which apply over the full operating temperature range, otherwise specifications are at  $T_A = 25^\circ\text{C}$ .  $V_{IN} = 12\text{V}$ , unless otherwise noted.

SYMBOL	PARAMETER	CONDITIONS	MIN	TYP	MAX	UNITS
<b>Supplies</b>						
$V_{IN}$	Input Supply Range		● 2.9		18	V
$I_{IN}$	Input Supply Current		●	2	4	mA
$V_{INTVCC}$	Internal Regulator Voltage		● 4.5	5	5.6	V
$V_{INTVCC(UVL)}$	Internal $V_{CC}$ Undervoltage Lockout	INTV <sub>CC</sub> Rising	● 2.1	2.2	2.3	V
$\Delta V_{INTVCC(HYST)}$	Internal $V_{CC}$ Undervoltage Lockout Hysteresis		● 30	60	90	mV
<b>Ideal Diode Control</b>						
$\Delta V_{FWD(REG)}$	Forward Regulation Voltage ( $V_{INn} - V_{SENSE^+}$ )		● 10	25	40	mV
$\Delta V_{DGATE}$	External N-Channel Gate Drive ( $V_{DGATEn} - V_{INn}$ )	$I_N < 7\text{V}$ , $\Delta V_{FWD} = 0.1\text{V}$ , $I = 0$ , $-1\mu\text{A}$	● 5	7	14	V
		$I_N = 7\text{V to } 18\text{V}$ , $\Delta V_{FWD} = 0.1\text{V}$ , $I = 0$ , $-1\mu\text{A}$	● 10	12	14	V
$I_{CPO(UP)}$	CPOn Pull-Up Current	$CPO = I_N = 2.9\text{V}$	● -60	-95	-120	$\mu\text{A}$
		$CPO = I_N = 18\text{V}$	● -50	-85	-110	$\mu\text{A}$
$I_{DGATE(FPU)}$	DGATEn Fast Pull-Up Current	$\Delta V_{FWD} = 0.2\text{V}$ , $\Delta V_{DGATE} = 0\text{V}$ , $CPO = 17\text{V}$		-1.5		A
$I_{DGATE(FPD)}$	DGATEn Fast Pull-Down Current	$\Delta V_{FWD} = -0.2\text{V}$ , $\Delta V_{DGATE} = 5\text{V}$		1.5		A
$I_{DGATE2(DN)}$	DGATE2 Off Pull-Down Current	$\overline{D2ON} = 2\text{V}$ , $\Delta V_{DGATE2} = 2.5\text{V}$	● 40	100	200	$\mu\text{A}$
$t_{ON(DGATE)}$	DGATEn Turn-On Delay	$\Delta V_{FWD} = 0.2\text{V}$ , $C_{DGATE} = 10\text{nF}$	●	0.25	0.5	$\mu\text{s}$
$t_{OFF(DGATE)}$	DGATEn Turn-Off Delay	$\Delta V_{FWD} = -0.2\text{V}$ , $C_{DGATE} = 10\text{nF}$	●	0.2	0.5	$\mu\text{s}$
$t_{PLH(DGATE2)}$	$\overline{D2ON}$ Low to DGATE2 High		●	40	100	$\mu\text{s}$

## ELECTRICAL CHARACTERISTICS

The ● denotes the specifications which apply over the full operating temperature range, otherwise specifications are at  $T_A = 25^\circ\text{C}$ .  $V_{IN} = 12\text{V}$ , unless otherwise noted.

SYMBOL	PARAMETER	CONDITIONS		MIN	TYP	MAX	UNITS
<b>Hot Swap Control</b>							
$\Delta V_{\text{SENSE(CB)}}$	Circuit Breaker Trip Sense Voltage ( $V_{\text{SENSE}^+} - V_{\text{SENSE}^-}$ )		●	47.5	50	52.5	mV
$\Delta V_{\text{SENSE(ACL)}}$	Active Current Limit Sense Voltage ( $V_{\text{SENSE}^+} - V_{\text{SENSE}^-}$ )		●	60	65	70	mV
$\Delta V_{\text{HGATE}}$	External N-Channel Gate Drive ( $V_{\text{HGATE}} - V_{\text{OUT}}$ )	IN < 7V, I = 0, -1 $\mu\text{A}$	●	4.8	7	14	V
		IN = 7V to 18V, I = 0, -1 $\mu\text{A}$	●	10	12	14	V
$\Delta V_{\text{HGATE(PG)}}$	Gate-Source Voltage for Power Good		●	3.6	4.2	4.8	V
$I_{\text{HGATE(UP)}}$	External N-Channel Gate Pull-Up Current	Gate Drive On, HGATE = 0V	●	-7	-10	-13	$\mu\text{A}$
$I_{\text{HGATE(DN)}}$	External N-Channel Gate Pull-Down Current	Gate Drive Off OUT = 12V, HGATE = OUT + 5V	●	150	300	500	$\mu\text{A}$
$I_{\text{HGATE(FPD)}}$	External N-Channel Gate Fast Pull-Down Current	Fast Turn-Off OUT = 12V, HGATE = OUT + 5V	●	100	200	300	mA
$t_{\text{PHL(SENSE)}}$	Sense Voltage (SENSE+ – SENSE-) High to HGATE Low	$\Delta V_{\text{SENSE}} = 300\text{mV}$ , $C_{\text{HGATE}} = 10\text{nF}$	●		0.5	1	$\mu\text{s}$
$t_{\text{OFF(HGATE)}}$	$\overline{\text{EN}}$ High to HGATE Low ON Low to HGATE Low SENSE+ Low to HGATE Low		●		20	40	$\mu\text{s}$
			●		10	20	$\mu\text{s}$
			●		10	20	$\mu\text{s}$
$t_{\text{D(HGATE)}}$	ON High, $\overline{\text{EN}}$ Low to HGATE Turn-On Delay	LTC4227-1, LTC4227-2	●	50	100	150	ms
		LTC4227-3, LTC4227-4	●	0.8	1.6	2.4	ms
$t_{\text{P(HGATE)}}$	ON to HGATE Propagation Delay	ON = Step 0.8V to 2V	●		10	20	$\mu\text{s}$
<b>Input/Output Pin</b>							
$I_{\text{SENSE}^+}$	SENSE+ Input Current	SENSE+ = 12V	●		1.2	2.2	mA
$I_{\text{SENSE}^-}$	SENSE- Input Current	SENSE- = 12V	●	10	50	100	$\mu\text{A}$
$V_{\text{SENSE}^+(\text{UVL})}$	SENSE+ Undervoltage Lockout	SENSE+ Rising	●	1.75	1.9	2.05	V
$\Delta V_{\text{SENSE}^+(\text{HYST})}$	SENSE+ Undervoltage Lockout Hysteresis		●	10	50	90	mV
$V_{\text{ON(TH)}}$	ON Pin Threshold Voltage	ON Rising	●	1.21	1.235	1.26	V
$\Delta V_{\text{ON(HYST)}}$	ON Pin Hysteresis		●	40	80	140	mV
$V_{\text{ON(RESET)}}$	ON Pin Fault Reset Threshold Voltage	ON Falling	●	0.55	0.6	0.65	V
$V_{\text{D2ON(H,TH)}}$	$\overline{\text{D2ON}}$ Pin High Threshold	$\overline{\text{D2ON}}$ Rising	●	1.21	1.235	1.26	V
$V_{\text{D2ON(L,TH)}}$	$\overline{\text{D2ON}}$ Pin Low Threshold	$\overline{\text{D2ON}}$ Falling	●	1.07	1.145	1.22	V
$\Delta V_{\text{D2ON(HYST)}}$	$\overline{\text{D2ON}}$ Pin Hysteresis		●	40	90	140	mV
$I_{\text{IN(LEAK)}}$	Input Leakage Current (ON, $\overline{\text{D2ON}}$ )	ON = $\overline{\text{D2ON}} = 5\text{V}$	●		0	$\pm 1$	$\mu\text{A}$
$V_{\text{EN(TH)}}$	$\overline{\text{EN}}$ Pin Threshold Voltage	$\overline{\text{EN}}$ Rising	●	1.185	1.235	1.284	V
$\Delta V_{\text{EN(HYST)}}$	$\overline{\text{EN}}$ Pin Hysteresis		●	40	110	200	mV
$I_{\text{EN(UP)}}$	$\overline{\text{EN}}$ Pull-Up Current	$\overline{\text{EN}} = 1\text{V}$	●	-7	-10	-13	$\mu\text{A}$
$V_{\text{TMR(TH)}}$	TMR Pin Threshold Voltage	TMR Rising	●	1.198	1.235	1.272	V
		TMR Falling	●	0.15	0.2	0.25	V
$I_{\text{TMR(UP)}}$	TMR Pull-Up Current	TMR = 1V, In Fault Mode	●	-75	-100	-125	$\mu\text{A}$
$I_{\text{TMR(DN)}}$	TMR Pull-Down Current	TMR = 2V, No Faults	●	1.4	2	2.6	$\mu\text{A}$
$I_{\text{TMR(RATIO)}}$	TMR Current Ratio $I_{\text{TMR(DN)}}/I_{\text{TMR(UP)}}$		●	1.4	2	2.7	%
$I_{\text{OUT}}$	OUT Pin Current	OUT = 11V, IN = 12V, ON = 2V	●		50	100	$\mu\text{A}$
		OUT = 13V, IN = 12V, ON = 2V	●		1.9	4	mA
$V_{\text{OL}}$	Output Low Voltage ( $\overline{\text{FAULT}}$ , $\overline{\text{PWRGD}}$ )	I = 1mA	●		0.15	0.4	V

**ELECTRICAL CHARACTERISTICS** The ● denotes the specifications which apply over the full operating temperature range, otherwise specifications are at  $T_A = 25^\circ\text{C}$ .  $V_{IN} = 12\text{V}$ , unless otherwise noted.

SYMBOL	PARAMETER	CONDITIONS	MIN	TYP	MAX	UNITS
$V_{OH}$	Output High Voltage (FAULT, PWRGD)	$I = -1\mu\text{A}$	● $\text{INTV}_{CC} - 1$	$\text{INTV}_{CC} - 0.5$		V
$I_{OH}$	Input Leakage Current (FAULT, PWRGD)	$V = 18\text{V}$	●	0	$\pm 1$	$\mu\text{A}$
$I_{PU}$	Output Pull-Up Current (FAULT, PWRGD)	$V = 1.5\text{V}$	●	-7	-10	$\mu\text{A}$
$t_{RST(ON)}$	ON Low to FAULT High		●	20	40	$\mu\text{s}$

**Note 1:** Stresses beyond those listed under Absolute Maximum Ratings may cause permanent damage to the device. Exposure to any Absolute Maximum Rating condition for extended periods may affect device reliability and lifetime.

**Note 2:** All currents into device pins are positive; all currents out of the device pins are negative. All voltages are referenced to GND unless otherwise specified.

**Note 3:** An internal clamp limits the DGATE and CPO pins to a minimum of 10V above and a diode below IN. Driving these pins to voltages beyond the clamp may damage the device.

**Note 4:** An internal clamp limits the HGATE pin to a minimum of 10V above and a diode below OUT. Driving this pin to voltages beyond the clamp may damage the device.

**TYPICAL PERFORMANCE CHARACTERISTICS**  $T_A = 25^\circ\text{C}$ ,  $V_{IN} = 12\text{V}$ , unless otherwise noted.

IN Supply Current vs Voltage

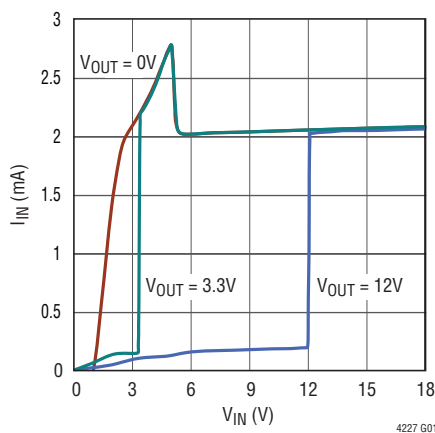

4227 G01

INTV<sub>CC</sub> Load Regulation

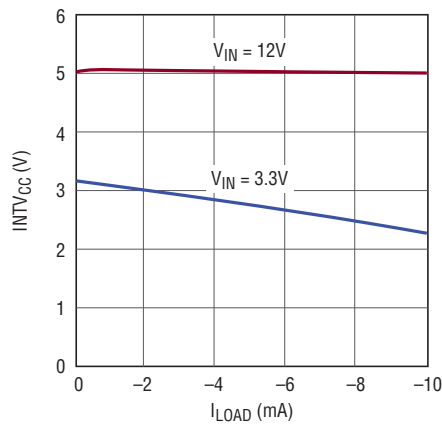

4227 G02

CPO Voltage vs Current

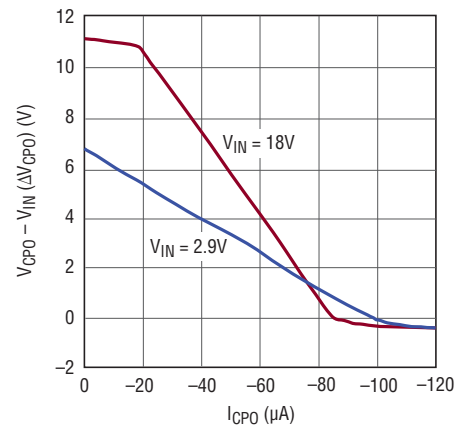

4227 G03

Diode Gate Voltage vs Current

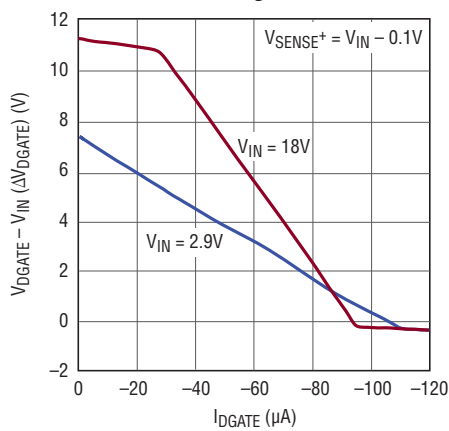

4227 G04

Diode Gate Voltage vs IN Voltage

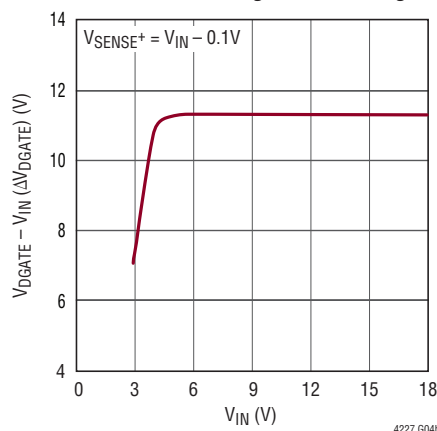

4227 G04b

Hot Swap Gate Voltage vs Current

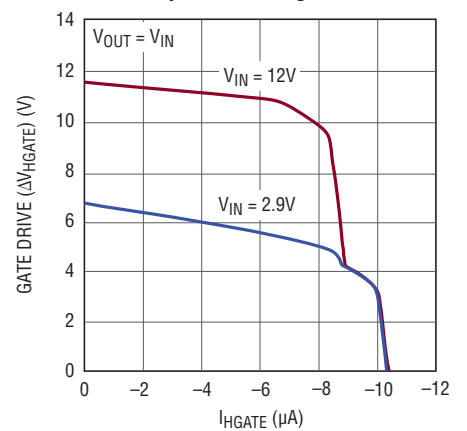

4227 G05

422712fa

## TYPICAL PERFORMANCE CHARACTERISTICS $T_A = 25^\circ\text{C}$ , $V_{IN} = 12\text{V}$ , unless otherwise noted.

**Hot Swap Gate Voltage vs IN Voltage**

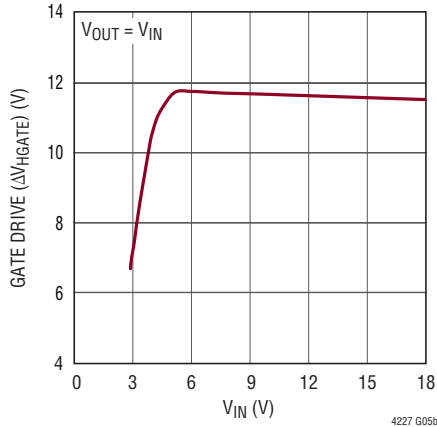

**OUT Current vs Voltage**

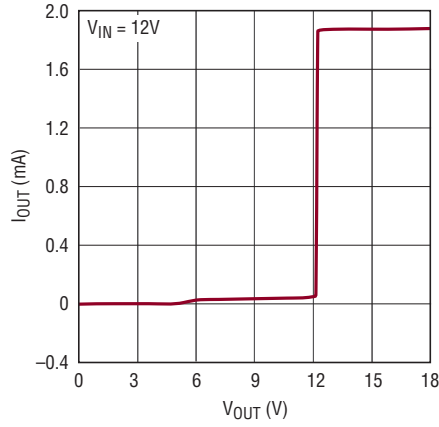

**Circuit Breaker Trip Voltage vs Temperature**

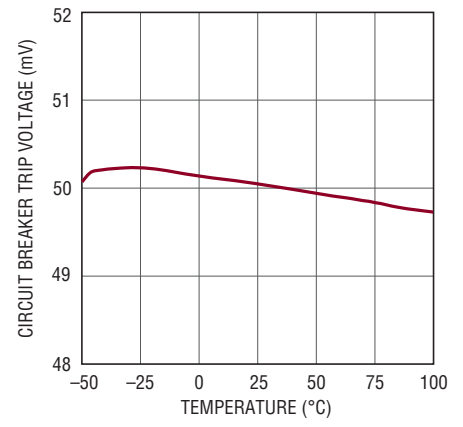

**Active Current Limit Sense Voltage vs Temperature**

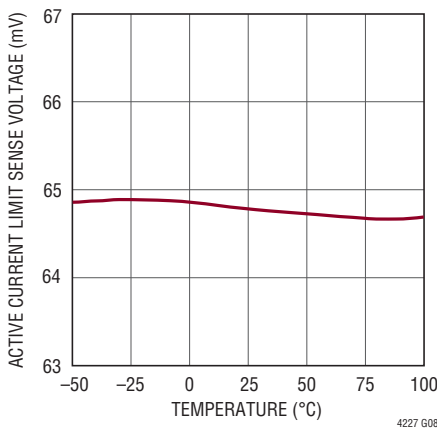

**Active Current Limit Delay vs Sense Voltage**

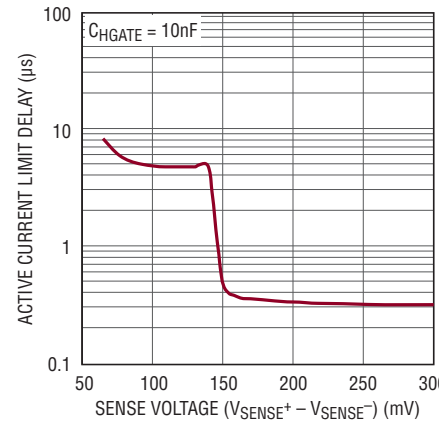

**HGATE Pull-Up Current vs Temperature**

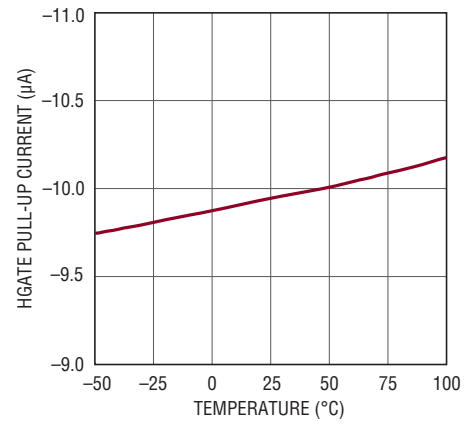

**TMR Pull-Up Current vs Temperature**

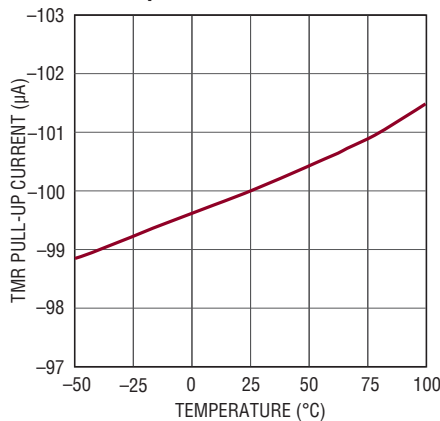

**PWRGD, FAULT Output Low Voltage vs Current**

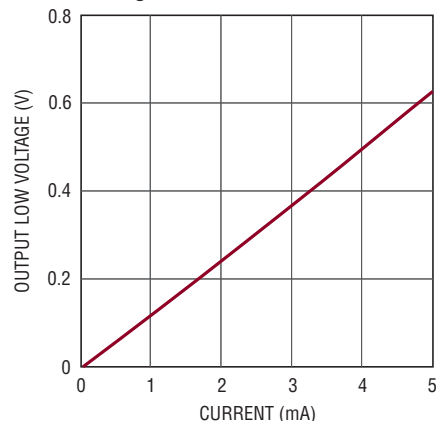

## PIN FUNCTIONS

**CPO1, CPO2:** Charge Pump Output. Connect a capacitor from CPO1 or CPO2 to the corresponding IN1 or IN2 pin. The value of this capacitor is approximately 10× the gate capacitance ( $C_{ISS}$ ) of the external MOSFET for ideal diode control. The charge stored on this capacitor is used to pull up the gate during a fast turn-on. Leave this pin open if fast turn-on is not needed.

**DGATE1, DGATE2:** Ideal Diode MOSFET Gate Drive Output. Connect this pin to the gate of an external N-channel MOSFET for ideal diode control. An internal clamp limits the gate voltage to 12V above and a diode voltage below IN. During fast turn-on, a 1.5A pull-up charges DGATE from CPO. During fast turn-off, a 1.5A pull-down discharges DGATE to IN.

**D2ON:** On Control Input. A voltage below 1.145V allows the external ideal diode MOSFET in the IN2 supply path to turn on and a voltage above 1.235V turns it off. Connect this pin to an external resistive divider from IN1 to make IN1 the higher priority input supply when IN1 and IN2 are equal.

**$\overline{EN}$  (UFD Package):** Enable Input. Ground this pin to enable Hot Swap control. If this pin is pulled high, the MOSFET is not allowed to turn on. A 10 $\mu$ A current source pulls this pin up to a diode below INTV<sub>CC</sub>. Upon  $\overline{EN}$  going low when ON is high, an internal timer provides a 100ms start-up delay for debounce, after which the fault is cleared.

**Exposed Pad (UFD Package):** Exposed pad may be left open or connected to device ground.

**FAULT (UFD Package):** Fault Status Output. Open-drain output that is normally pulled high by a 10 $\mu$ A current source to a diode below INTV<sub>CC</sub>. It may be pulled above INTV<sub>CC</sub> using an external pull-up. It pulls low when the circuit breaker is tripped after an overcurrent fault timeout. Leave open if unused.

**GND:** Device Ground.

**HGATE:** Hot Swap MOSFET Gate Drive Output. Connect this pin to the gate of the external N-channel MOSFET for Hot Swap control. An internal 10 $\mu$ A current source charges the MOSFET gate. An internal clamp limits the gate voltage to 12V above and a diode voltage below OUT. During

turn-off, a 300 $\mu$ A pull-down discharges HGATE to ground. During an output short or INTV<sub>CC</sub> undervoltage lockout, a fast 200mA pull-down discharges HGATE to OUT.

**IN1, IN2:** Positive Supply Input and MOSFET Gate Drive Return. Connect this pin to the power input side of the external ideal diode MOSFET. The 5V INTV<sub>CC</sub> supply is generated from IN1 and IN2 via an internal diode-OR. The voltage sensed at this pin is used to control DGATE. The gate fast pull-down current returns through this pin when DGATE is discharged.

**INTV<sub>CC</sub>:** Internal 5V Supply Decoupling Output. This pin must have a 0.1 $\mu$ F or larger capacitor. An external load of less than 500 $\mu$ A can be connected at this pin.

**NC (UFD Package):** No Connection. Not internally connected.

**ON:** On Control Input. A rising edge above 1.235V turns on the external Hot Swap MOSFET and a falling edge below 1.155V turns it off. Connect this pin to an external resistive divider from SENSE<sup>+</sup> to monitor the supply undervoltage condition. Pulling the ON pin below 0.6V resets the electronic circuit breaker.

**OUT:** MOSFET Gate Drive Return. Connect this pin to the output side of the external Hot Swap MOSFET. The gate fast pull-down current returns through this pin when HGATE is discharged.

**PWRGD:** Power Status Output. Open-drain output that is normally pulled high by a 10 $\mu$ A current source to a diode below INTV<sub>CC</sub>. It may be pulled above INTV<sub>CC</sub> using an external pull-up. It pulls low when the MOSFET gate drive between HGATE and OUT exceeds the gate-to-source voltage of 4.2V. Leave open if unused.

**SENSE<sup>+</sup>:** Positive Current Sense Input. Connect this pin to the diode-OR output of the external ideal diode MOSFETs and input of the current sense resistor. The voltage sensed at this pin is used for monitoring the current limit and also to control DGATE for forward voltage regulation and reverse turn-off. This pin has an undervoltage lockout threshold of 1.9V that will turn off the Hot Swap MOSFET.

**SENSE<sup>-</sup>:** Negative Current Sense Input. Connect this pin to the output of the current sense resistor. The current

## PIN FUNCTIONS

limit circuit controls HGATE to limit the voltage between SENSE<sup>+</sup> and SENSE<sup>-</sup> to 65mV. A circuit breaker trips when the sense voltage exceeds 50mV for more than a fault filter delay configured at the TMR pin.

**TMR:** Timer Capacitor Terminal. Connect a capacitor between this pin and ground to set a 12ms/μF duration for current limit before the external Hot Swap MOSFET is turned off. The duration of the off-time is 617ms/μF, resulting in a 2% duty cycle.

## BLOCK DIAGRAM

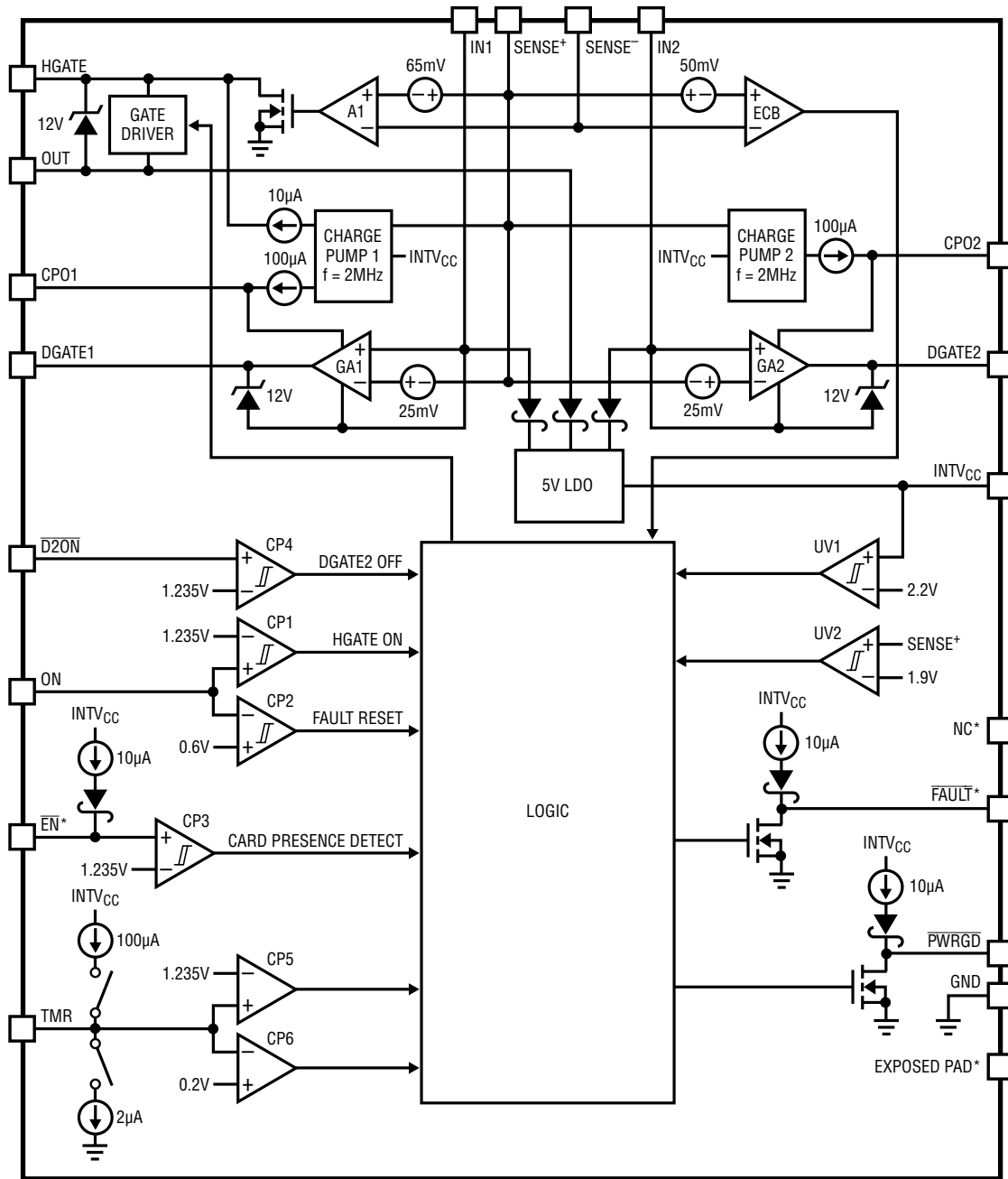

\*UFD PACKAGE ONLY

422712 BD

## OPERATION

The LTC4227 functions as an input supply diode-OR with inrush current limiting and overcurrent protection by controlling the external N-channel MOSFETs ( $M_{D1}$ ,  $M_{D2}$  and  $M_H$ ) on a supply path. This allows boards to be safely inserted and removed in systems with a backplane powered by redundant supplies. The LTC4227 has a single Hot Swap controller and two separate ideal diode controllers, each providing independent control for the two input supplies.

When the LTC4227 is first powered up, the gates of the MOSFETs are all held low, keeping them off. As the DGATE2 pull-up can be disabled by the  $\overline{D2ON}$  pin, DGATE2 will pull high only when the  $\overline{D2ON}$  pin is pulled low. The gate drive amplifier (GA1, GA2) monitors the voltage between the IN and SENSE<sup>+</sup> pins and drives the respective DGATE pin. The amplifier quickly pulls up the DGATE pin, turning on the MOSFET for ideal diode control, when it senses a large forward voltage drop. With the ideal diode MOSFETs acting as an input supply diode-OR, the SENSE<sup>+</sup> pin voltage rises to the highest of the supplies at the IN1 and IN2 pins. The stored charge in an external capacitor connected between the CPO and IN pins provides the charge needed to quickly turn on the ideal diode MOSFET. An internal charge pump charges up this capacitor at device power-up. The DGATE pin sources current from the CPO pin and sinks current into the IN and GND pins.

Pulling the ON pin high and  $\overline{EN}$  pin low initiates a debounce timing cycle (100ms for LTC4227-1/LTC4227-2 and 1.6ms for LTC4227-3/LTC4227-4). After this timing cycle, a 10 $\mu$ A current source from the charge pump ramps up the HGATE pin. When the Hot Swap MOSFET turns on, the inrush current is limited at a level set by an external sense resistor ( $R_S$ ) connected between the SENSE<sup>+</sup> and SENSE<sup>-</sup> pins. An active current limit amplifier (A1) servos the gate of the MOSFET to 65mV across the current sense resistor. Inrush current can be further reduced, if desired, by add-

ing a capacitor from HGATE to GND. When the MOSFET's gate overdrive (HGATE to OUT voltage) exceeds 4.2V, the  $\overline{PWRGD}$  pin pulls low.

When the ideal diode MOSFET is turned on, the gate drive amplifier controls DGATE to servo the forward voltage drop ( $V_{IN} - V_{SENSE^+}$ ) across the MOSFET to 25mV. If the load current causes more than 25mV of voltage drop, the gate voltage rises to enhance the MOSFET. For large output currents, the MOSFET's gate is driven fully on and the voltage drop is equal to  $I_{LOAD} \cdot R_{DS(ON)}$  of the MOSFET.

In the case of an input supply short-circuit when the MOSFETs are conducting, a large reverse current starts flowing from the load towards the input. The gate drive amplifier detects this failure condition as soon as it appears and turns off the ideal diode MOSFET by pulling down the DGATE pin.

In the case where an overcurrent fault occurs on the supply output, the current is limited to  $65mV/R_S$ . After a fault filter delay set by 100 $\mu$ A charging the TMR pin capacitor, the circuit breaker trips and pulls the HGATE pin low, turning off the Hot Swap MOSFET. The  $\overline{FAULT}$  pin is latched low. At this point, the DGATE pin continues to pull high and keeps the ideal diode MOSFET on.

Internal clamps limit both the DGATE to IN and CPO to IN voltages to 12V. The same clamp also limits the CPO and DGATE pins to a diode voltage below the IN pin. Another internal clamp limits the HGATE to OUT voltage to 12V and also clamps the HGATE pin to a diode voltage below the OUT pin.

Power to the LTC4227 is supplied from either the IN or OUT pins, through an internal diode-OR circuit to a low dropout regulator (LDO). That LDO generates a 5V supply at the INTV<sub>CC</sub> pin and powers the LTC4227's internal low voltage circuitry.

## APPLICATIONS INFORMATION

High availability systems often employ parallel-connected power supplies or battery feeds to achieve redundancy and enhance system reliability. Power ORing diodes are commonly used to connect these supplies at the point of load, but at the expense of power loss due to significant diode forward voltage drop. The LTC4227 minimizes this power loss by using external N-channel MOSFETs for the pass elements, allowing for a low voltage drop from the supply to the load when the MOSFETs are turned on (see Figure 1). When the input source voltage drops below the output common supply voltage, the appropriate MOSFET is turned off, thereby matching the function and performance of an ideal diode. By adding a current sense resistor and a Hot Swap MOSFET after the parallel-connected ideal diode MOSFETs, the LTC4227 enhances the ideal diode performance with inrush current limiting and overcurrent protection. This allows the boards to be safely inserted and removed from a live backplane without damaging the connector.

### Internal V<sub>CC</sub> Supply

The LTC4227 can operate with input supplies from 2.9V to 18V at the IN pins. The power supply to the device is internally regulated at 5V by a low dropout regulator (LDO) with an output at the INTV<sub>CC</sub> pin. An internal diode-OR

circuit selects the highest of the supplies at the IN and OUT pins to power the device through the LDO. The diode-OR scheme permits the device's power to be temporarily kept alive by the OUT load capacitance when the IN supplies have collapsed or shut off.

An undervoltage lockout circuit prevents all of the MOSFETs from turning on until the INTV<sub>CC</sub> voltage exceeds 2.2V. A 0.1μF capacitor is recommended between the INTV<sub>CC</sub> and GND pins, close to the device for bypassing. No external supply should be connected at the INTV<sub>CC</sub> pin so as not to affect the LDO's operation. A small external load of less than 500μA can be connected at the INTV<sub>CC</sub> pin.

### Turn-On Sequence

The board power supply at the OUT pin is controlled with external N-channel MOSFETs (M<sub>D1</sub>, M<sub>D2</sub> and M<sub>H</sub>). The ideal diode MOSFETs connected in parallel on the supply side function as a diode-OR, while M<sub>H</sub> on the load side acts as a Hot Swap controlling the power supplied to the output load. The sense resistor, R<sub>S</sub>, monitors the load current for overcurrent detection. The HGATE capacitor, C<sub>HG</sub>, controls the gate slew rate to limit the inrush current. Resistor R<sub>HG</sub> with C<sub>HG</sub> compensates the current control loop, while R<sub>H</sub> prevents high frequency oscillations in the Hot Swap MOSFET.

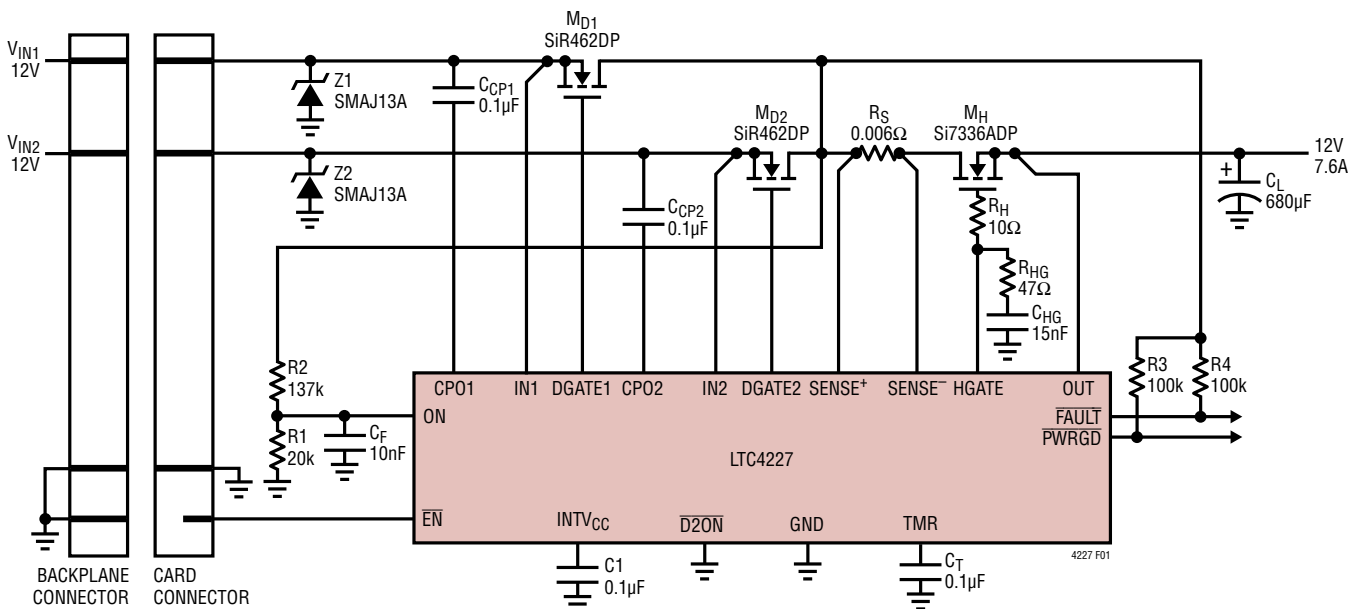

Figure 1. Card Resident Diode-OR with Hot Swap Application

422712fa

## APPLICATIONS INFORMATION

During a normal power-up, the ideal diode MOSFETs turn on first. As soon as the internally generated supply,  $\overline{\text{INTV}}_{\text{CC}}$ , rises above its 2.2V undervoltage lockout threshold, the internal charge pump is allowed to charge up the CPO pins. Because the ideal diode MOSFETs are connected in parallel as a diode-OR, the  $\text{SENSE}^+$  pin voltage approaches the highest of the supplies at the IN1 and IN2 pins. The MOSFET associated with the lower input supply voltage will be turned off by the corresponding gate drive amplifier.

Before the Hot Swap MOSFET can be turned on,  $\overline{\text{EN}}$  must remain low and ON must remain high for a  $t_{\text{D(HGATE)}}$  debounce timing cycle to ensure that any contact bounces during the insertion have ceased. At the end of the debounce cycle, the internal fault latches are cleared. The Hot Swap MOSFET is then allowed to turn on by charging up HGATE with a  $10\mu\text{A}$  current source from the charge pump. The voltage at the HGATE pin rises with a slope equal to  $10\mu\text{A}/C_{\text{HG}}$  and the supply inrush current flowing into the load capacitor,  $C_{\text{L}}$ , is limited to:

$$I_{\text{INRUSH}} = \frac{C_{\text{L}}}{C_{\text{HG}}} \cdot 10\mu\text{A}$$

The OUT voltage follows the HGATE voltage when the Hot Swap MOSFET turns on. If the voltage across the current sense resistor,  $R_{\text{S}}$ , becomes too high, the inrush current will be limited by the internal current limiting circuitry. Once the MOSFET gate overdrive exceeds 4.2V, the  $\overline{\text{PWRGD}}$  pin pulls low to indicate that the power is good. Once OUT reaches the input supply voltage, HGATE continues to ramp up. An internal 12V clamp limits the HGATE voltage above OUT.

When the ideal diode MOSFET is turned on, the gate drive amplifier controls the gate of the MOSFET to servo the forward voltage drop across the MOSFET to 25mV. If the load current causes more than 25mV of drop, the MOSFET gate is driven fully on and the voltage drop is equal to  $I_{\text{LOAD}} \cdot R_{\text{DS(ON)}}$ .

### Turn-Off Sequence

The external MOSFETs can be turned off by a variety of conditions. A normal turn-off for the Hot Swap MOSFET is initiated by pulling the ON pin below its 1.155V threshold (80mV ON pin hysteresis), or pulling the  $\overline{\text{EN}}$  pin above

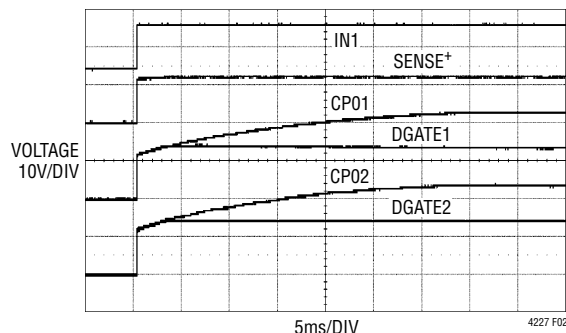

Figure 2. Ideal Diode Controller Start-Up Waveforms

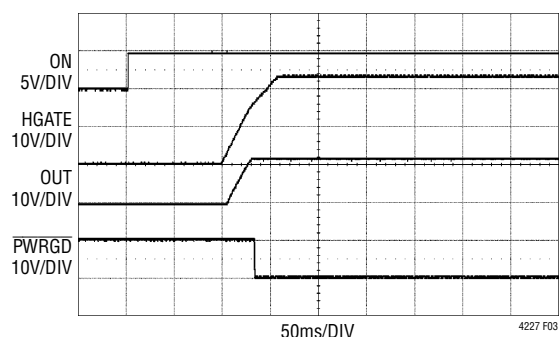

Figure 3. LTC4227-1/LTC4227-2 Hot Swap Controller Power-Up Sequence

its 1.235V threshold. Additionally, an overcurrent fault of sufficient duration to trip the circuit breaker also turns off the Hot Swap MOSFET. Normally, the LTC4227 turns off the MOSFET by pulling the HGATE pin to ground with a  $300\mu\text{A}$  current sink.

All of the MOSFETs turn off when  $\overline{\text{INTV}}_{\text{CC}}$  falls below its undervoltage lockout threshold (2.2V). The DGATE pin is pulled down with a  $100\mu\text{A}$  current to one diode voltage below the IN pin, while the HGATE pin is pulled down to the OUT pin by a 200mA current. When  $\overline{\text{D2ON}}$  is pulled high above 1.235V, the ideal diode MOSFET in the IN2 supply path is turned off with DGATE2 pulled low by a  $100\mu\text{A}$  current.

The gate drive amplifier controls the ideal diode MOSFET to prevent reverse current when the input supply falls below  $\text{SENSE}^+$ . If the input supply collapses quickly, the gate drive amplifier turns off the MOSFET with a fast pull-down circuit as soon as it detects that IN is 25mV below  $\text{SENSE}^+$ . If the input supply falls at a more modest rate, the gate drive amplifier controls the MOSFET to maintain  $\text{SENSE}^+$  at 25mV below IN.

422712fa

## APPLICATIONS INFORMATION

### Board Presence Detect with $\overline{\text{EN}}$

If ON is high when the  $\overline{\text{EN}}$  pin goes low, indicating a board presence, the LTC4227 initiates a debounce timing cycle for contact debounce. Upon board insertion, any bounces on the  $\overline{\text{EN}}$  pin restart the timing cycle. When the debounce timing cycle is done, the internal fault latches are cleared. If the  $\overline{\text{EN}}$  pin remains low at the end of the timing cycle, HGATE is charged up with a 10 $\mu\text{A}$  current source to turn on the Hot Swap MOSFET.

If the  $\overline{\text{EN}}$  pin goes high, indicating a board removal, the HGATE pin is pulled low with a 300 $\mu\text{A}$  current sink after a 20 $\mu\text{s}$  delay, turning off the Hot Swap MOSFET, without clearing any latched faults.

### Overcurrent Fault

The LTC4227 features an adjustable current limit with circuit breaker function that protects the external MOSFETs against short circuits or excessive load current. The voltage across the external sense resistor,  $R_S$ , is monitored by an electronic circuit breaker (ECB) and active current limit (ACL) amplifier. The electronic circuit breaker will turn off the Hot Swap MOSFET with a 300 $\mu\text{A}$  current from HGATE to GND if the voltage across the sense resistor exceeds  $\Delta V_{\text{SENSE(CB)}}$  (50mV) for longer than the fault filter delay configured at the TMR pin.

Active current limiting begins when the sense voltage exceeds the ACL threshold  $\Delta V_{\text{SENSE(ACL)}}$  (65mV), which is 1.3 $\times$  the ECB threshold  $\Delta V_{\text{SENSE(CB)}}$ . The gate of the Hot Swap MOSFET is brought under control by the ACL amplifier and the output current is regulated to maintain the ACL threshold across the sense resistor. At this point, the fault filter starts the timeout with a 100 $\mu\text{A}$  current charging the TMR pin capacitor. If the TMR pin voltage exceeds its threshold (1.235V), the external MOSFET turns off with HGATE pulled to ground by 300 $\mu\text{A}$ , and its associated  $\overline{\text{FAULT}}$  pulls low.

After the Hot Swap MOSFET turns off, the TMR pin capacitor is discharged with a 2 $\mu\text{A}$  pull-down current until its threshold reaches 0.2V. This is followed by a cool-off period of 14 timing cycles at the TMR pin. For the latch-off part (LTC4227-1/LTC4227-3), the HGATE pin voltage does not restart at the end of the cool-off period, unless

the latched fault is cleared by pulling the ON pin low or toggling the  $\overline{\text{EN}}$  pin from high to low. For the auto-retry part (LTC4227-2/LTC4227-4), the latched fault is cleared automatically at the end of the cool-off period, and the HGATE pin restarts charging up to turn on the MOSFET. Figure 4 shows an overcurrent fault on the 12V output.

In the event of a severe short-circuit fault on the 12V output as shown in Figure 5, the output current can surge to tens of amperes. The LTC4227 responds within 1 $\mu\text{s}$  to bring the current under control by pulling the HGATE to OUT voltage down to zero volts. Almost immediately, the gate of the Hot Swap MOSFET recovers due to the  $R_{\text{HG}}$  and  $C_{\text{HG}}$  network, and current is actively limited until the electronic circuit breaker times out. Due to parasitic supply lead inductance, an input supply without any bypass capacitor may collapse during the high current surge and then spike upwards when the current is interrupted. Figure 9 shows the input supply transient suppressors consisting of Z1,  $R_{\text{SNUB1}}$ ,  $C_{\text{SNUB1}}$  and Z2,  $R_{\text{SNUB2}}$ ,  $C_{\text{SNUB2}}$  for the two supplies if there is no input capacitance.

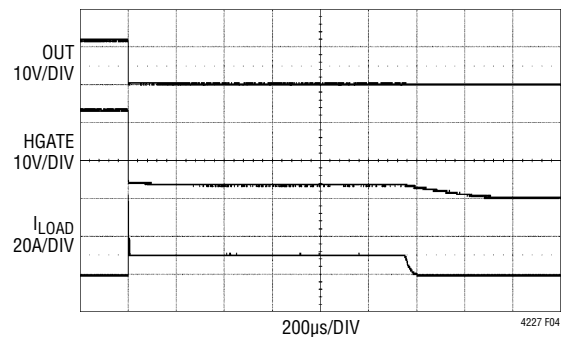

Figure 4. Overcurrent Fault on 12V Output

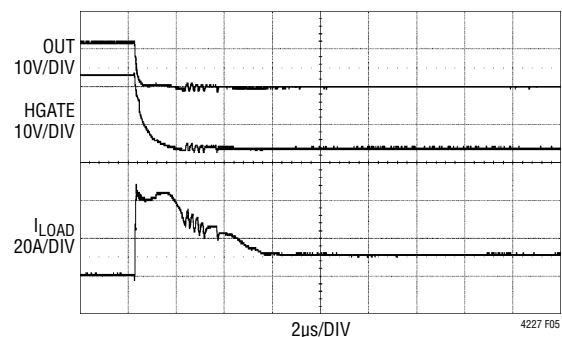

Figure 5. Severe Short-Circuit on 12V Output

## APPLICATIONS INFORMATION

### Active Current Loop Stability

The active current loop on the HGATE pin is compensated by the parasitic gate capacitance of the external N-channel MOSFET. No further compensation components are normally required. In the case when a MOSFET with  $C_{ISS} \leq 2\text{nF}$  is chosen, an  $R_{HG}$  and  $C_{HG}$  compensation network connected at the HGATE pin may be required. The value of  $C_{HG}$  is selected based on the inrush current allowed for the output load capacitance. The resistor,  $R_{HG}$ , connected in series with  $C_{HG}$  accelerates the MOSFET gate recovery for active current limiting after a fast gate pull-down due to an output short. The value of  $C_{HG}$  should be  $\leq 100\text{nF}$  and  $R_{HG}$  should be between  $10\Omega$  and  $100\Omega$  for optimum performance.

### TMR Pin Functions

An external capacitor,  $C_T$ , connected from the TMR pin to GND serves as fault filtering when the supply output is in active current limit. When the voltage across the sense resistor exceeds the circuit breaker trip threshold ( $50\text{mV}$ ), TMR pulls up with  $100\mu\text{A}$ . Otherwise, it pulls down with  $2\mu\text{A}$ . The fault filter times out when the  $1.235\text{V}$  TMR threshold is exceeded, causing the corresponding  $\overline{\text{FAULT}}$  pin to pull low. The fault filter delay or circuit breaker time delay is:

$$t_{CB} = C_T \cdot 12[\text{ms}/\mu\text{F}].$$

After the circuit breaker timeout, the TMR pin capacitor pulls down with  $2\mu\text{A}$  from the  $1.235\text{V}$  TMR threshold until it reaches  $0.2\text{V}$ . Then, it completes 14 cooling cycles consisting of the TMR pin capacitor charging to  $1.235\text{V}$  with a  $100\mu\text{A}$  current and discharging to  $0.2\text{V}$  with a  $2\mu\text{A}$  current. At that point, the HGATE pin voltage is allowed to start up if the fault has been cleared as described in the Resetting Faults section. When the latched fault is cleared during the cool-off period, the corresponding  $\overline{\text{FAULT}}$  pin pulls high. The total cool-off time for the MOSFET after an overcurrent fault is:

$$t_{COOL} = C_T \cdot 11[\text{s}/\mu\text{F}]$$

If the latched fault is not cleared after the cool-off period, the cooling cycles continue until the fault is cleared.

After the cool-off period, the HGATE pin is only allowed to pull up if the fault has been cleared for the latch-off

part. For the auto-retry part, the latched fault is cleared automatically following the cool-off period and the HGATE pin voltage is allowed to restart.

### Resetting Faults (LTC4227-1/LTC4227-3)

For the latch-off part, an overcurrent fault is latched after tripping the circuit breaker, and the  $\overline{\text{FAULT}}$  pin is asserted low. Only the Hot Swap MOSFET is turned off and the ideal diode MOSFETs are not affected.

To reset a latched fault and restart the output, pull the ON pin below  $0.6\text{V}$  for more than  $100\mu\text{s}$  and then high above  $1.235\text{V}$ . The fault latches reset and the  $\overline{\text{FAULT}}$  pin deasserts on the falling edge of the ON pin. When ON goes high again, a debounce timing cycle is initiated before the HGATE pin voltage restarts. Toggling the  $\overline{\text{EN}}$  pin high and then low again also resets a fault, but the  $\overline{\text{FAULT}}$  pin pulls high at the end of the debounce timing cycle before the HGATE pin voltage starts up. Bringing all the supplies below the  $\text{INTV}_{CC}$  undervoltage lockout threshold ( $2.2\text{V}$ ) shuts off all the MOSFETs and resets all the fault latches. A debounce timing cycle is initiated before a normal start-up when any of the supplies is restored above the  $\text{INTV}_{CC}$  UVLO threshold.

### Auto-Retry After a Fault (LTC4227-2/LTC4227-4)

For the auto-retry part, the latched fault is reset automatically after a cool-off timing cycle as described in the TMR Pin Functions section. At the end of the cool-off period, the fault latch is cleared and  $\overline{\text{FAULT}}$  pulls high. The HGATE pin voltage is allowed to start up and turn on the Hot Swap MOSFET. If the output short persists, the supply powers up into a short with active current limiting until the circuit breaker times out and  $\overline{\text{FAULT}}$  again pulls low. A new cool-off cycle begins with TMR ramping down with a  $2\mu\text{A}$  current. The whole process repeats itself until the output short is removed. Since  $t_{CB}$  and  $t_{COOL}$  are a function of TMR capacitance,  $C_T$ , the auto-retry duty cycle is equal to  $0.1\%$ , irrespective of  $C_T$ .

Figure 6 shows an auto-retry sequence after an overcurrent fault.

## APPLICATIONS INFORMATION

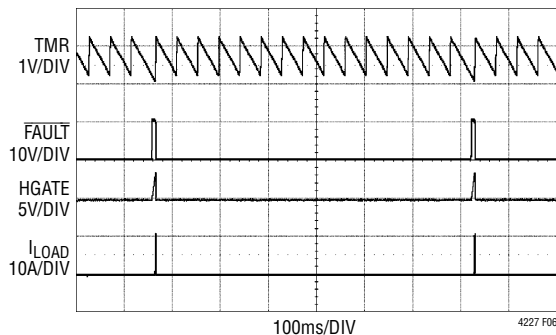

Figure 6. Auto-Retry Sequence After a Fault

### Supply Undervoltage Monitor

The ON pin functions as a turn-on control and an input supply monitor. A resistive divider connected between the supply diode-OR output (SENSE<sup>+</sup>) and GND at the ON pin monitors the supply undervoltage condition. The undervoltage threshold is set by proper selection of the resistors, and is given by:

$$V_{IN(UVTH)} = \left(1 + \frac{R2}{R1}\right) \cdot V_{ON(TH)}$$

where  $V_{ON(TH)}$  is the ON rising threshold (1.235V).

An undervoltage fault occurs if the diode-OR output supply falls below its undervoltage threshold for longer than 20 $\mu$ s. The FAULT pin will not be pulled low. If the ON pin voltage falls below 1.155V but remains above 0.6V, the Hot Swap MOSFET is turned off by a 300 $\mu$ A pull-down from HGATE to ground. The Hot Swap MOSFET turns back on instantly without the debounce timing cycle when the diode-OR output supply rises above its undervoltage threshold.

However, if the ON pin voltage drops below 0.6V, it turns off the Hot Swap MOSFET and clears the fault latches. The Hot Swap MOSFET turns back on only after a debounce timing cycle when the diode-OR output supply is restored above its undervoltage threshold. The ideal diode MOSFETs are not affected by the undervoltage fault conditions.

If both IN supplies fall until the internally generated supply, INTV<sub>CC</sub>, drops below its 2.2V UVLO threshold, all the MOSFETs are turned off and the fault latches are cleared. Operation resumes from a fresh start-up cycle when the input supplies are restored and INTV<sub>CC</sub> exceeds its UVLO threshold.

There is a 10 $\mu$ s glitch filter on the ON pin to reject supply glitches. By placing a filter capacitor, C<sub>F</sub>, with the resistive divider at the ON pin, the glitch filter delay is further extended by the RC time constant to prevent any false fault.

### Power Good Monitor

Internal circuitry monitors the MOSFET gate overdrive between the HGATE and OUT pins. The power good status for the supply is reported via the open-drain output, PWRGD. It is normally pulled high by an external pull-up resistor or the internal 10 $\mu$ A pull-up. The power good output asserts low when the gate overdrive exceeds 4.2V during the HGATE start-up. Once asserted low, the power good status is latched and can only be cleared by pulling the ON pin low, toggling the  $\overline{EN}$  pin from low to high, or INTV<sub>CC</sub> entering undervoltage lockout. The power good output continues to pull low while HGATE is regulating in active current limit, but pulls high when the circuit breaker times out and pulls the HGATE pin low.

### CPO and DGATE Start-Up

The CPO and DGATE pin voltages are initially pulled up to a diode below the IN pin when first powered up. CPO starts ramping up 7 $\mu$ s after INTV<sub>CC</sub> clears its undervoltage lockout level. Another 40 $\mu$ s later, DGATE also starts ramping up with CPO. The CPO ramp rate is determined by the CPO pull-up current into the combined CPO and DGATE pin capacitances. An internal clamp limits the CPO pin voltage to 12V above the IN pin, while the final DGATE pin voltage is determined by the gate drive amplifier. An internal 12V clamp limits the DGATE pin voltage above IN.

### MOSFET Selection

The LTC4227 drives N-channel MOSFETs to conduct the load current. The important features of the MOSFETs are on-resistance, R<sub>DS(ON)</sub>, the maximum drain-source voltage, BV<sub>DSS</sub>, and the threshold voltage.

The gate drive for the ideal diode MOSFET and Hot Swap MOSFET is guaranteed to be greater than 5V and 4.8V respectively when the supply voltages at IN1 and IN2 are between 2.9V and 7V. When the supply voltages at IN1 and IN2 are greater than 7V, the gate drive is guaranteed

## APPLICATIONS INFORMATION

to be greater than 10V. The gate drive is limited to not more than 14V. This allows the use of logic-level threshold N-channel MOSFETs and standard N-channel MOSFETs above 7V. An external Zener diode can be used to clamp the potential from the MOSFET's gate to source if the rated breakdown voltage is less than 14V.

The maximum allowable drain-source voltage,  $BV_{DSS}$ , must be higher than the supply voltages as the full supply voltage can appear across the MOSFET. If an input or output is connected to ground, the full supply voltage will appear across the MOSFET. The  $R_{DS(ON)}$  should be small enough to conduct the maximum load current, and also stay within the MOSFET's power rating.

### CPO Capacitor Selection

The recommended value of the capacitor,  $C_{CP}$ , between the CPO and IN pins is approximately 10× the input capacitance,  $C_{ISS}$ , of the ideal diode MOSFET. A larger capacitor takes a correspondingly longer time to charge up by the internal charge pump. A smaller capacitor suffers more voltage drop during a fast gate turn-on event as it shares charge with the MOSFET gate capacitance.

### Supply Transient Protection

When the capacitances at the input and output are very small, rapid changes in current during an input or output short-circuit event can cause transients that exceed the 24V absolute maximum ratings of the IN and OUT pins. To minimize such spikes, use wider traces or heavier trace plating to reduce the power trace inductance. Also, bypass locally with a 10 $\mu$ F electrolytic and 0.1 $\mu$ F ceramic, or alternatively clamp the input with a transient voltage suppressor (Z1, Z2). A 10 $\Omega$ , 0.1 $\mu$ F snubber damps the response and eliminates ringing (See Figure 9).

### Design Example

As a design example for selecting components, consider a 12V system with a 7.6A maximum load current for the two supplies (see Figure 1).

First, select the appropriate value of the current sense resistor,  $R_S$ , for the 12V supply. Calculate the sense resistor

value based on the maximum load current and the lower limit for the circuit breaker threshold,  $\Delta V_{SENSE(CB)(MIN)}$ :

$$R_S = \frac{\Delta V_{SENSE(CB)(MIN)}}{I_{LOAD(MAX)}} = \frac{47.5mV}{7.6A} = 6.25m\Omega$$

Choose a 6m $\Omega$  sense resistor with a 1% tolerance. The minimum and maximum circuit breaker trip current is calculated as follows:

$$I_{TRIP(MIN)} = \frac{\Delta V_{SENSE(CB)(MIN)}}{R_{S(MAX)}} = \frac{47.5mV}{6.06m\Omega} = 7.8A$$

$$I_{TRIP(MAX)} = \frac{\Delta V_{SENSE(CB)(MAX)}}{R_{S(MIN)}} = \frac{52.5mV}{5.94m\Omega} = 8.8A$$

For proper operation,  $I_{TRIP(MIN)}$  must exceed the maximum load current with margin, so  $R_S = 6m\Omega$  should suffice for the 12V supply.

Next, calculate the  $R_{DS(ON)}$  of the ideal diode MOSFET to achieve the desired forward drop at maximum load. Assuming a forward drop,  $\Delta V_{FWD}$  of 60mV across the MOSFET:

$$R_{DS(ON)} \leq \frac{\Delta V_{FWD}}{I_{LOAD(MAX)}} = \frac{60mV}{7.6A} = 7.9m\Omega$$

The SiR462DP offers a good choice with a maximum  $R_{DS(ON)}$  of 7.9m $\Omega$  at  $V_{GS} = 10V$ . The input capacitance,  $C_{ISS}$ , of the SiR462DP is about 1155pF. Slightly exceeding the 10× recommendation, a 0.1 $\mu$ F capacitor is selected for  $C_{CP1}$  and  $C_{CP2}$  at the CPO pins.

Next, verify that the thermal ratings of the selected Hot Swap MOSFET, Si7336ADP, are not exceeded during power-up or an output short.

Assuming the MOSFET dissipates power due to inrush current charging the load capacitor,  $C_L$ , at power-up, the energy dissipated in the MOSFET is the same as the energy stored in the load capacitor, and is given by:

$$E_{CL} = \frac{1}{2} \cdot C_L \cdot V_{IN}^2$$

## APPLICATIONS INFORMATION

For  $C_L = 680\mu\text{F}$ , the time it takes to charge up  $C_L$  is calculated as:

$$t_{\text{CHARGE}} = \frac{C_L \cdot V_{\text{IN}}}{I_{\text{INRUSH}}} = \frac{680\mu\text{F} \cdot 12\text{V}}{0.5\text{A}} = 16\text{ms}$$

The inrush current is set to 0.5A by adding capacitance,  $C_{\text{HG}}$ , at the gate of the Hot Swap MOSFET.

$$C_{\text{HG}} = \frac{C_L \cdot I_{\text{HGATE(UP)}}}{I_{\text{INRUSH}}} = \frac{680\mu\text{F} \cdot 10\mu\text{A}}{0.5\text{A}} \cong 15\text{nF}$$

The average power dissipated in the MOSFET is calculated as:

$$P_{\text{AVG}} = \frac{E_{\text{CL}}}{t_{\text{CHARGE}}} = \frac{1}{2} \cdot \frac{680\mu\text{F} \cdot (12\text{V})^2}{16\text{ms}} = 3\text{W}$$

The MOSFET selected must be able to tolerate 3W for 16ms during power-up. The SOA curves of the Si7336ADP provide for 1.5A at 30V (45W) for 100ms. This is sufficient to satisfy the requirement. The increase in junction temperature due to the power dissipated in the MOSFET is  $\Delta T = P_{\text{AVG}} \cdot Z_{\text{thJC}}$  where  $Z_{\text{thJC}}$  is the junction-to-case thermal impedance. Under this condition, the Si7336ADP data sheet indicates that the junction temperature will increase by 2.4°C using  $Z_{\text{thJC}} = 0.8^\circ\text{C/W}$  (single pulse).

The duration and magnitude of the power pulse during an output short is a function of the TMR capacitance,  $C_T$ , and the LTC4227's active current limit. The short-circuit duration is given as  $C_T \cdot 12[\text{ms}/\mu\text{F}] = 1.2\text{ms}$  for  $C_T = 0.1\mu\text{F}$ . The maximum short-circuit current is calculated using the maximum active current limit threshold,  $\Delta V_{\text{SENSE(ACL)(MAX)}}$  and minimum  $R_S$  value.

$$I_{\text{SHORT(MAX)}} = \frac{\Delta V_{\text{SENSE(ACL)(MAX)}}}{R_{\text{S(MIN)}}} = \frac{70\text{mV}}{5.94\text{m}\Omega} = 11.8\text{A}$$

So, the maximum power dissipated in the MOSFET is  $11.8\text{A} \cdot 12\text{V} = 142\text{W}$  for 1.2ms. The Si7336ADP data sheet indicates that the worst-case increase in junction temperature during this short-circuit condition is

21.3°C using  $Z_{\text{thJC}} = 0.15^\circ\text{C/W}$  (single pulse). Choosing  $C_T = 0.1\mu\text{F}$  will not cause the maximum junction temperature of the MOSFET to be exceeded. The SOA curves of the Si7336ADP provide for 6A at 30V (180W) for 10ms. This also satisfies the requirement.

Next, select the resistive divider at the ON pin to provide an undervoltage threshold of 9.6V for the 12V supply at SENSE<sup>+</sup>. First, choose the bottom resistor, R1, to be 20k. Then, calculate the top resistor value for R2:

$$R2 = \left( \frac{V_{\text{IN(UVTH)}}}{V_{\text{ON(TH)}}} - 1 \right) \cdot R1$$

$$R2 = \left( \frac{9.6\text{V}}{1.235\text{V}} - 1 \right) \cdot 20\text{k} = 135\text{k}$$

Choose the nearest 1% resistor value of 137k for R2. In addition, there is a 0.1μF bypass, C1, at the INTV<sub>CC</sub> pin and a 10nF filter capacitor, C<sub>F</sub>, at the ON pin to prevent the supply glitches from turning off the Hot Swap MOSFET.

### PCB Layout Considerations

For proper operation of the LTC4227's circuit breaker, Kelvin connection to the sense resistor is strongly recommended. The PCB layout should be balanced and symmetrical to minimize wiring errors. In addition, the PCB layout for the sense resistor and the power MOSFET should include good thermal management techniques for optimal device power dissipation. A recommended PCB layout is illustrated in Figure 7.

Connect the IN and OUT pin traces as close as possible to the MOSFETs' terminals. Keep the traces to the MOSFETs wide and short to minimize resistive losses. The PCB traces associated with the power path through the MOSFETs should have low resistance. The suggested trace width for 1oz copper foil is 0.03" for each ampere of DC current to keep PCB trace resistance, voltage drop and temperature rise to a minimum. Note that the sheet resistance of 1oz copper foil is approximately 0.5mΩ/square, and voltage drops due to trace resistance add up quickly in high current applications.

It is also important to place the bypass capacitor, C1, for

## APPLICATIONS INFORMATION

the  $INTV_{CC}$  pin, as close as possible between  $INTV_{CC}$  and GND. Also place  $C_{CP1}$  near the CPO1 and IN1 pins, and  $C_{CP2}$  near the CPO2 and IN2 pins. The transient voltage suppressors, Z1 and Z2, when used, should be mounted close to the LTC4227 using short lead lengths.

### Prioritizing Supplies with $\overline{D2ON}$

Figure 8 shows a diode-OR application where a resistive divider connected from IN1 at the  $\overline{D2ON}$  pin can suppress the turn-on of the ideal diode MOSFET,  $M_{D2}$ , in the IN2 supply path. When the IN1 supply voltage falls below 2.8V, it allows the ideal diode MOSFET,  $M_{D2}$ , to turn on, causing

the diode-OR output to be switched from the main 3.3V supply at IN1 to the auxiliary 3.3V supply at IN2. This configuration permits the load to be supplied from a lower IN1 supply as compared to IN2 until IN1 falls below the  $M_{D2}$  turn-on threshold. The threshold value used should not allow the IN1 supply to be operated at more than one diode voltage below IN2. Otherwise,  $M_{D2}$  conducts through the MOSFET's body diode. The resistive divider connected from SENSE+ at the ON pin provides the undervoltage threshold of 2.6V for the diode-OR output supply.

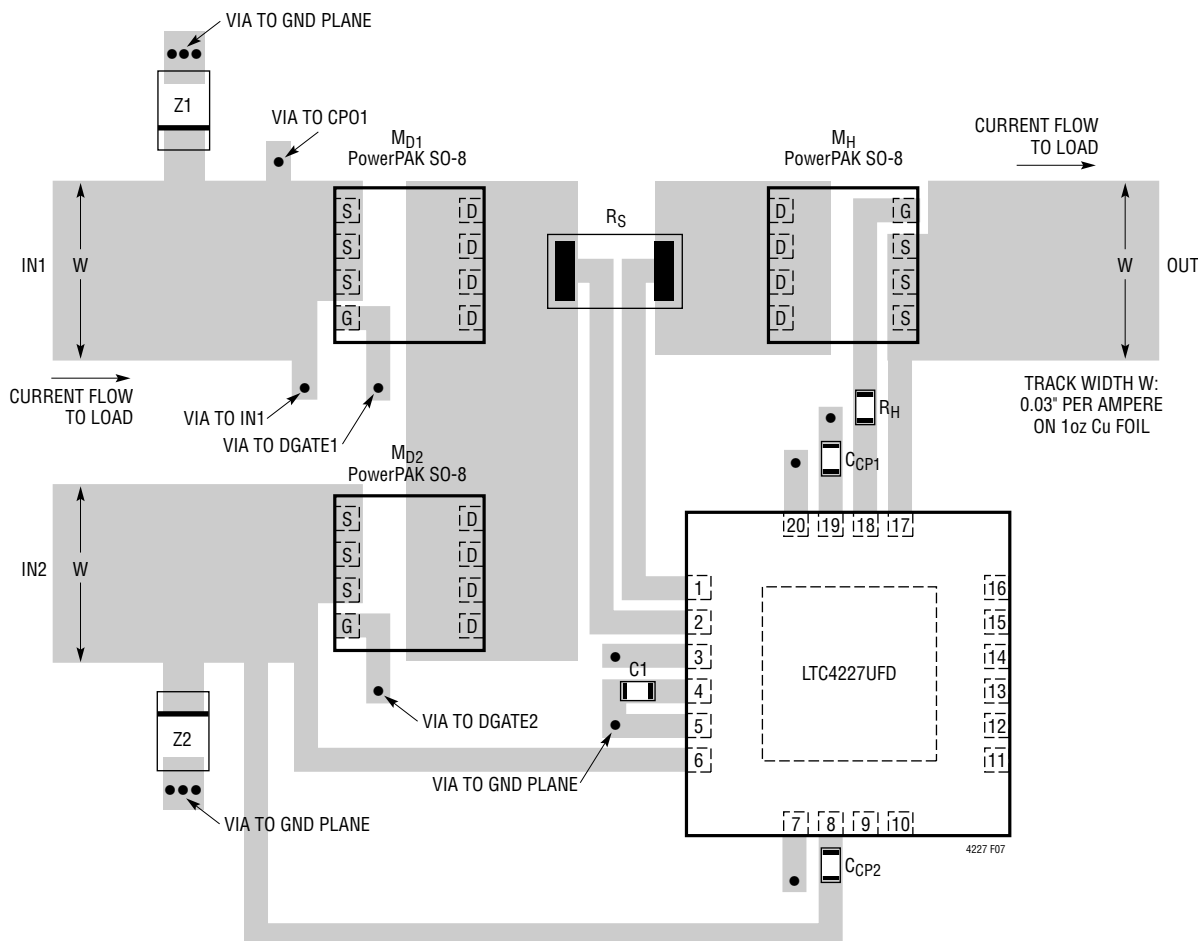

Figure 7. Recommended PCB Layout for Power MOSFETs and Sense Resistor





## PACKAGE DESCRIPTION

Please refer to <http://www.linear.com/designtools/packaging/> for the most recent package drawings.

### GN Package 16-Lead Plastic SSOP (Narrow .150 Inch) (Reference LTC DWG # 05-08-1641)

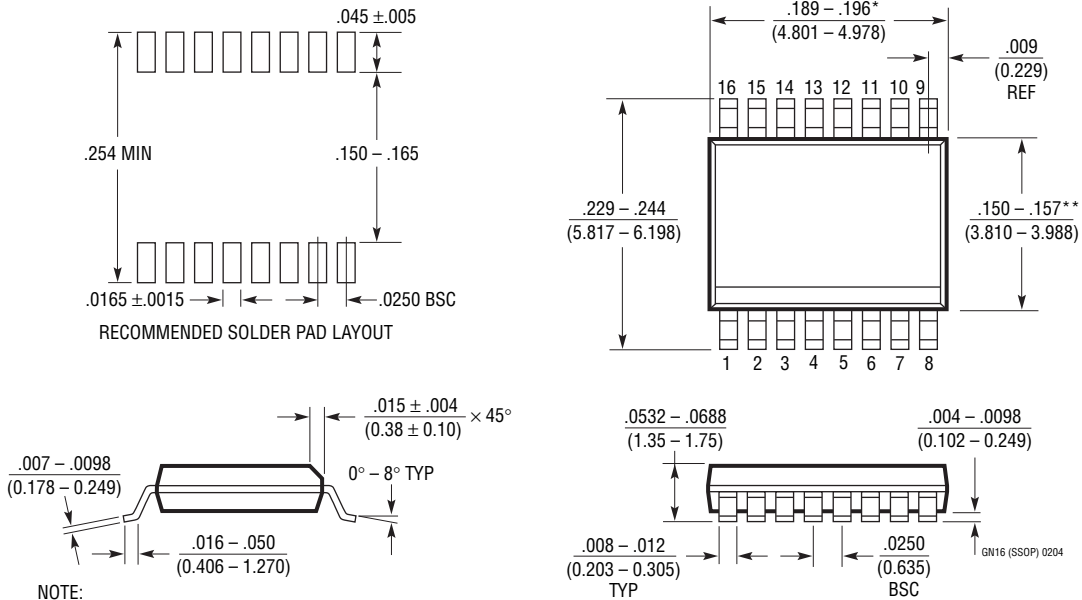

**NOTE:**

1. CONTROLLING DIMENSION: INCHES

2. DIMENSIONS ARE IN  $\frac{\text{INCHES}}{\text{(MILLIMETERS)}}$

3. DRAWING NOT TO SCALE

\*DIMENSION DOES NOT INCLUDE MOLD FLASH. MOLD FLASH SHALL NOT EXCEED 0.006" (0.152mm) PER SIDE

\*\*DIMENSION DOES NOT INCLUDE INTERLEAD FLASH. INTERLEAD FLASH SHALL NOT EXCEED 0.010" (0.254mm) PER SIDE



## REVISION HISTORY

REV	DATE	DESCRIPTION	PAGE NUMBER
A	07/13	Added LTC4227-3, LTC4227-4 information	Multiple
		Added specification: $V_{\overline{D20N}(L,TH)}$ , $\overline{D20N}$ Pin Low Threshold	4
		Changed $\Delta V_{\overline{D20N}(HYST)}$ typical value from 80mV to 90mV	4
		Added two curves to G01; Added Diode and Hot Swap Gate Voltage vs IN Voltage graphs	5, 6



## Looking for pricing, stock, or lifecycle information?

Click below to explore more details on WIN SOURCE:

-  [View LTC4227IGN-2#PBF on WIN SOURCE](#)
-  [Analog Devices Inc. Information](#)

## Optimize Your Supply Chain with WIN SOURCE Solutions

-  Global Sourcing Solution
-  Obsolete Management
-  Cost Control Management
-  Shortage Management
-  Alternative Solution
-  Excess Inventory Management