



**THE DATASHEET OF  
MRFG35010AR1**



# Gallium Arsenide PHEMT

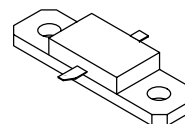
## RF Power Field Effect Transistor

Designed for WiMAX, WLL/MMDS or UMTS driver and final applications. Characterized from 500 to 5000 MHz. Device is unmatched and is suitable for use in Class AB or Class A linear base station applications.

- Typical Single-Carrier W-CDMA Performance:  $V_{DD} = 12$  Volts,  $I_{DQ} = 140$  mA,  $P_{out} = 1$  Watt Avg.,  $f = 3550$  MHz, Channel Bandwidth = 3.84 MHz, PAR = 8.5 dB @ 0.01% Probability on CCDF.  
Power Gain — 10 dB  
Drain Efficiency — 25%  
ACPR @ 5 MHz Offset — -43 dBc in 3.84 MHz Channel Bandwidth
- 10 Watts P1dB @ 3550 MHz, CW
- Excellent Phase Linearity and Group Delay Characteristics
- High Gain, High Efficiency and High Linearity
- RoHS Compliant
- In Tape and Reel. R1 Suffix = 500 Units per 32 mm, 13 inch Reel.

**MRFG35010AR1**

**3.5 GHz, 10 W, 12 V  
POWER FET  
GaAs PHEMT**



**CASE 360D-02, STYLE 1  
NI-360HF**

**Table 1. Maximum Ratings**

Rating	Symbol	Value	Unit
Drain-Source Voltage	$V_{DSS}$	15	Vdc
Gate-Source Voltage	$V_{GS}$	-5	Vdc
RF Input Power	$P_{in}$	33	dBm
Storage Temperature Range	$T_{stg}$	-65 to +150	°C
Channel Temperature (1)	$T_{ch}$	175	°C

**Table 2. Thermal Characteristics**

Characteristic	Symbol	Value (1, 2)	Unit
Thermal Resistance, Junction to Case	$R_{\theta JC}$		°C/W
Case Temperature 81°C, 10 W CW		4.0	
Case Temperature 79°C, 1 W CW		4.1	

**Table 3. ESD Protection Characteristics**

Test Methodology	Class
Human Body Model (per JESD22-A114)	1C (Minimum)
Machine Model (per EIA/JESD22-A115)	A (Minimum)
Charge Device Model (per JESD22-C101)	III (Minimum)

1. For reliable operation, the operating channel temperature should not exceed 150°C.
2. Refer to AN1955, *Thermal Measurement Methodology of RF Power Amplifiers*. Go to <http://www.freescale.com/rf>. Select Documentation/Application Notes - AN1955.

**Table 4. Electrical Characteristics** ( $T_C = 25^\circ\text{C}$  unless otherwise noted)

Characteristic	Symbol	Min	Typ	Max	Unit
Saturated Drain Current ( $V_{DS} = 3.5\text{ Vdc}$ , $V_{GS} = 0\text{ Vdc}$ )	$I_{DSS}$	—	2.9	—	Adc
Off State Leakage Current ( $V_{GS} = -0.4\text{ Vdc}$ , $V_{DS} = 0\text{ Vdc}$ )	$I_{GSS}$	—	< 1	100	$\mu\text{Adc}$
Off State Drain Current ( $V_{DS} = 12\text{ Vdc}$ , $V_{GS} = -2.2\text{ Vdc}$ )	$I_{DSO}$	—	0.09	1	mAdc
Off State Current ( $V_{DS} = 28.5\text{ Vdc}$ , $V_{GS} = -2.5\text{ Vdc}$ )	$I_{DSX}$	—	5	15	mAdc
Gate-Source Cut-off Voltage ( $V_{DS} = 3.5\text{ Vdc}$ , $I_{DS} = 15\text{ mA}$ )	$V_{GS(th)}$	-1.2	-0.8	-0.7	Vdc
Quiescent Gate Voltage ( $V_{DS} = 12\text{ Vdc}$ , $I_D = 180\text{ mA}$ )	$V_{GS(Q)}$	-1.2	-0.8	-0.7	Vdc

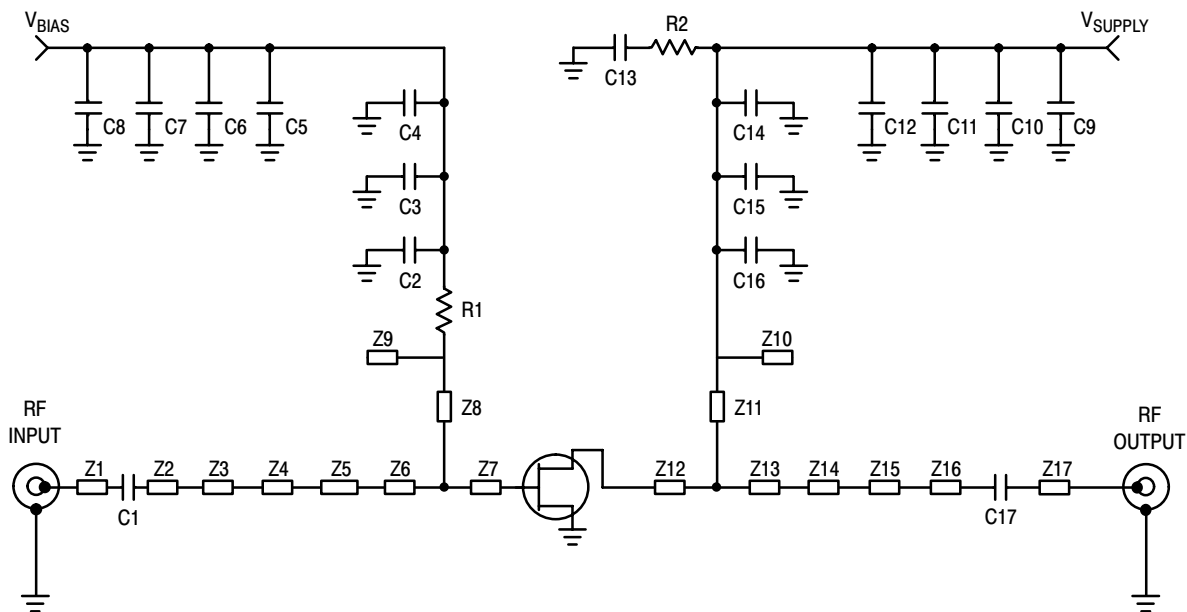
**Functional Tests** (In Freescale Test Fixture, 50 ohm system) <sup>(1)</sup>  $V_{DD} = 12\text{ Vdc}$ ,  $I_{DQ} = 140\text{ mA}$ ,  $P_{out} = 1\text{ W Avg.}$ ,  $f = 3550\text{ MHz}$ , Single-carrier W-CDMA, 3.84 MHz Channel Bandwidth Carrier. ACPR measured in 3.84 MHz Channel Bandwidth @  $\pm 5\text{ MHz}$  Offset. PAR = 8.5 dB @ 0.01% Probability on CCDF.

Power Gain	$G_{ps}$	9	10	—	dB
Drain Efficiency	$\eta_D$	23	25	—	%
Adjacent Channel Power Ratio	ACPR	—	-43	-40	dBc

**Typical RF Performance** (In Freescale Test Fixture, 50 ohm system)  $V_{DD} = 12\text{ Vdc}$ ,  $I_{DQ} = 140\text{ mA}$ ,  $f = 3550\text{ MHz}$

Output Power, 1 dB Compression Point, CW	P1dB	—	10	—	W
--	------	---	----	---	---

1. Measurements made with device in test fixture.



Z1	0.044" x 0.250" Microstrip	Z9, Z10	0.290" x 90° Microstrip Radial Stub
Z2	0.044" x 0.030" Microstrip	Z12	0.184" x 0.390" Microstrip
Z3	0.615" x 0.050" Microstrip	Z13	0.040" x 0.580" Microstrip
Z4	0.044" x 0.070" Microstrip	Z14	0.109" x 0.099" Microstrip
Z5	0.270" x 0.490" Microstrip	Z15	0.030" x 0.225" Microstrip
Z6	0.044" x 0.470" Microstrip	Z16	0.080" x 0.240" Microstrip
Z7	0.434" x 0.110" Microstrip	Z17	0.044" x 0.143" Microstrip
Z8, Z11	0.015" x 0.527" Microstrip	PCB	Rogers 4350, 0.020", $\epsilon_r = 3.5$

**Figure 1. 3.5 GHz Test Circuit Schematic**

**Table 5. 3.5 GHz Test Circuit Component Designations and Values**

Part	Description	Part Number	Manufacturer
C1, C17	6.8 pF Chip Capacitors	100A6R81BW150XT	ATC
C2, C16	10 pF Chip Capacitors	100A100JW150XT	ATC
C3, C15	100 pF Chip Capacitors	100A101JW150XT	ATC
C4, C13, C14	100 pF Chip Capacitors	100B101JW500XT	ATC
C5, C12	1000 pF Chip Capacitors	100B102JW500XT	ATC
C6, C11	0.1 $\mu$ F Chip Capacitors	200B104KW50XT	ATC
C7, C10	39K Chip Capacitors	200B393KW50XT	ATC
C8, C9	10 $\mu$ F, 50 V Chip Capacitors	GRM55DR61H106KA88B	Murata
R1, R2	50 $\Omega$ Chip Resistors	P51ETR-ND	Newark

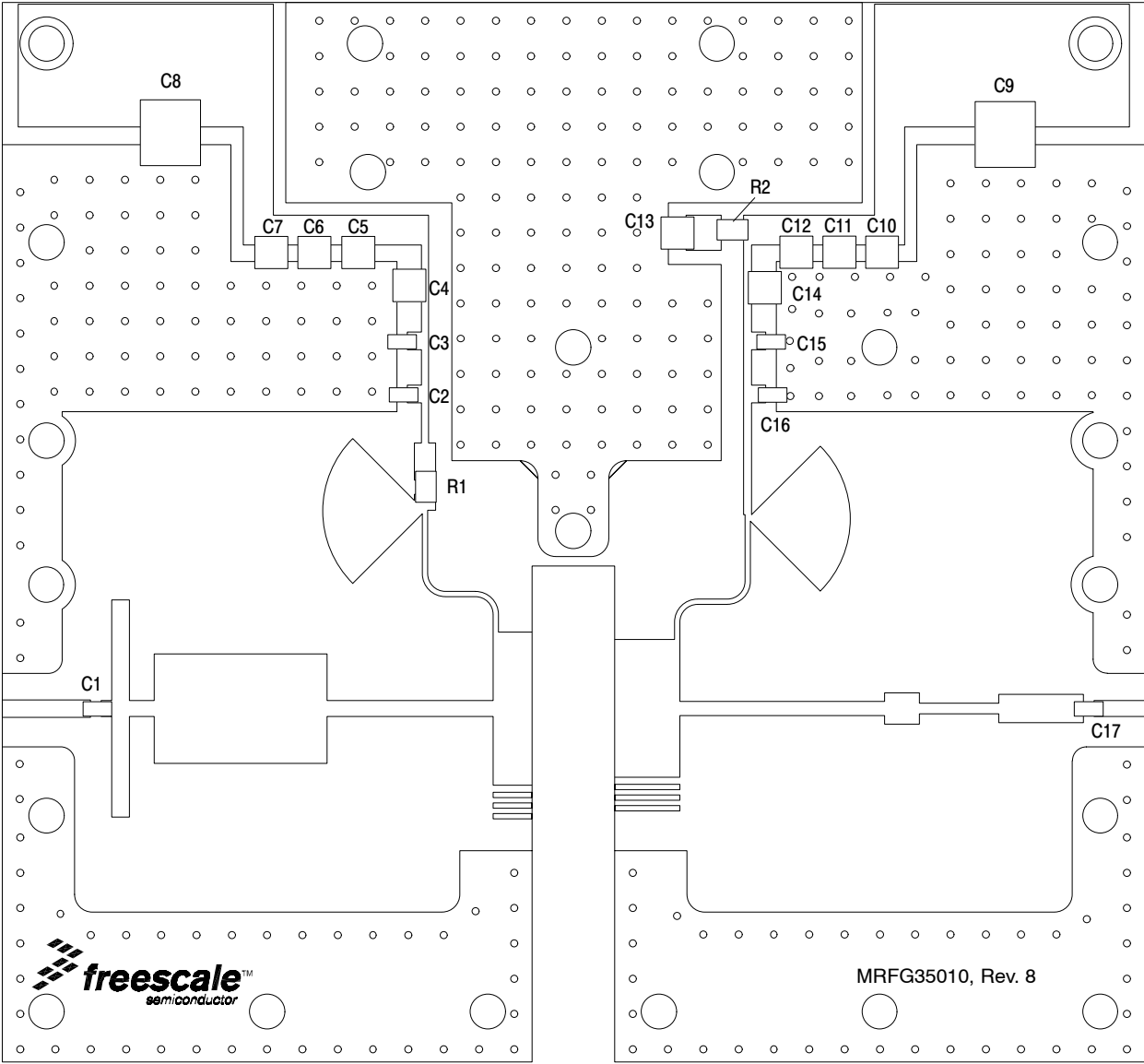
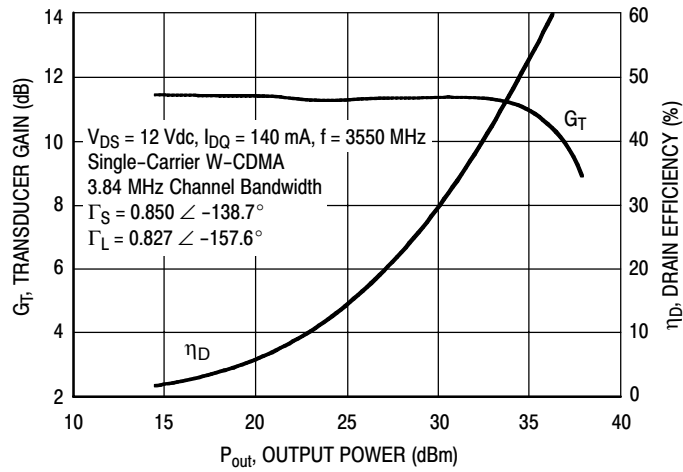
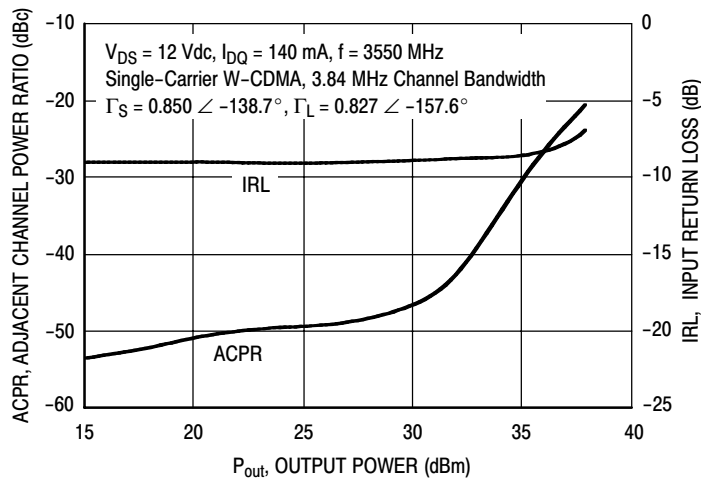


Figure 2. 3.5 GHz Test Circuit Component Layout

### TYPICAL CHARACTERISTICS



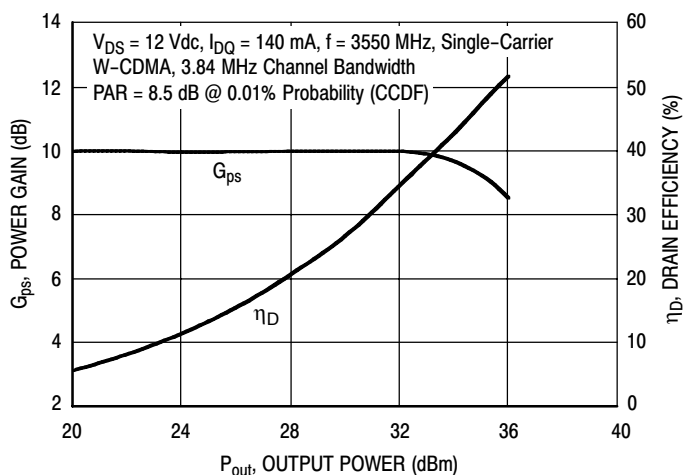
**Figure 3. Single-Carrier W-CDMA Power Gain and Drain Efficiency versus Output Power**



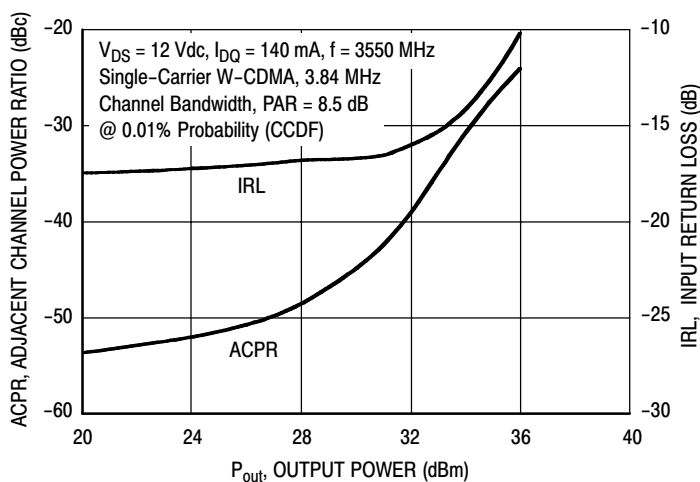
**Figure 4. Single-Carrier W-CDMA ACPR and Input Return Loss versus Output Power**

**NOTE:** All data is referenced to package lead interface.  $\Gamma_S$  and  $\Gamma_L$  are the impedances presented to the DUT. All data is generated from load pull, not from the test circuit shown.

### TYPICAL CHARACTERISTICS

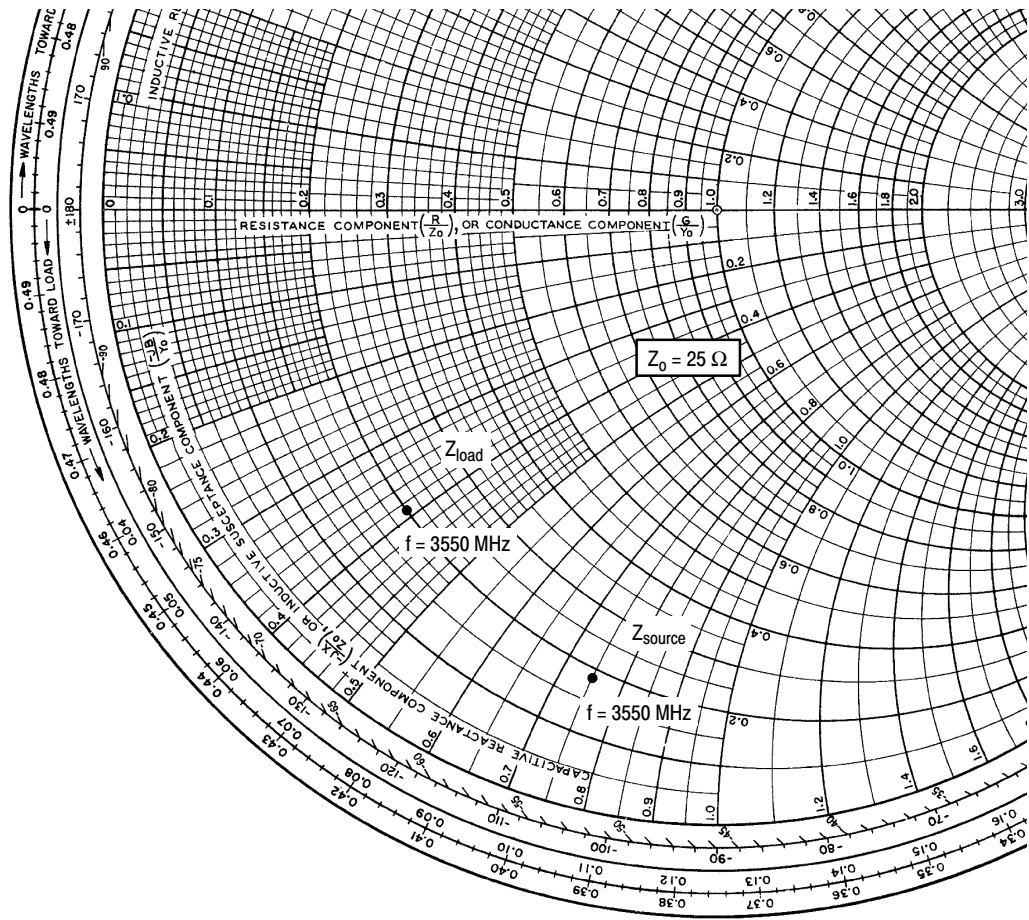


**Figure 5. Single-Carrier W-CDMA Power Gain and Drain Efficiency versus Output Power**



**Figure 6. Single-Carrier W-CDMA ACPR and Input Return Loss versus Output Power**

**NOTE:** Data is generated from the test circuit shown.



$V_{DD} = 12 \text{ Vdc}$ ,  $I_{DQ} = 140 \text{ mA}$ ,  $P_{out} = 1 \text{ W Avg.}$

f MHz	$Z_{source}$ $\Omega$	$Z_{load}$ $\Omega$
3550	$4.6 - j18.7$	$4.9 - j9.8$

$Z_{source}$  = Test circuit impedance as measured from gate to ground.

$Z_{load}$  = Test circuit impedance as measured from drain to ground.

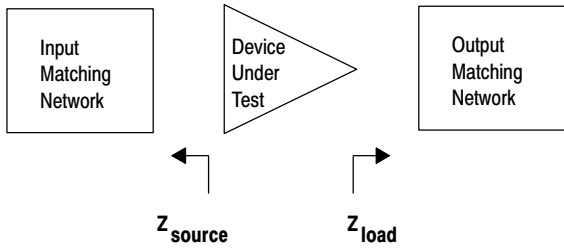


Figure 7. Series Equivalent Source and Load Impedance

**Table 6. Class AB Common Source S-Parameters** ( $V_{DD} = 12 \text{ Vdc}$ ,  $I_{DQ} = 1000 \text{ mA}$ ,  $T_C = 25^\circ\text{C}$ , 50 ohm system)

f GHz	S <sub>11</sub>		S <sub>21</sub>		S <sub>12</sub>		S <sub>22</sub>	
	S <sub>11</sub>	∠ φ	S <sub>21</sub>	∠ φ	S <sub>12</sub>	∠ φ	S <sub>22</sub>	∠ φ
0.25	0.959	-171.4	9.867	89.9	0.0083	16.6	0.784	-178.9
0.30	0.959	-173.7	8.220	87.6	0.0086	18.3	0.784	-179.6
0.35	0.956	-175.6	7.055	85.6	0.0083	19.5	0.784	179.7
0.40	0.959	-177.2	6.192	83.8	0.0088	20.0	0.783	179.2
0.45	0.959	-178.5	5.509	82.2	0.0089	22.4	0.782	178.7
0.50	0.959	-179.6	4.969	80.6	0.0089	22.7	0.781	178.2
0.55	0.959	179.3	4.525	79.0	0.0091	23.9	0.781	177.8
0.60	0.959	178.4	4.157	77.6	0.0094	26.0	0.780	177.4
0.65	0.958	177.5	3.844	76.2	0.0095	26.9	0.779	177.0
0.70	0.958	176.7	3.578	74.8	0.0098	28.0	0.779	176.7
0.75	0.958	175.8	3.347	73.4	0.0099	29.2	0.778	176.3
0.80	0.958	175.1	3.147	72.0	0.0103	30.6	0.777	176.0
0.85	0.958	174.3	2.971	70.7	0.0107	31.6	0.776	175.6
0.90	0.957	173.5	2.814	69.4	0.0108	32.0	0.776	175.3
0.95	0.957	172.9	2.675	68.1	0.0111	33.0	0.775	174.9
1.00	0.957	172.2	2.551	66.8	0.0114	33.8	0.774	174.6
1.05	0.958	171.5	2.439	65.4	0.0117	34.1	0.774	174.3
1.10	0.956	170.9	2.336	64.2	0.0119	34.7	0.773	173.9
1.15	0.956	170.1	2.244	62.8	0.0124	35.5	0.773	173.6
1.20	0.956	169.5	2.159	61.6	0.0126	35.3	0.772	173.2
1.25	0.955	168.8	2.083	60.3	0.0129	35.9	0.772	173.0
1.30	0.955	168.1	2.013	59.0	0.0133	36.1	0.772	172.6
1.35	0.955	167.5	1.948	57.7	0.0136	36.7	0.771	172.3
1.40	0.954	166.8	1.888	56.5	0.0139	36.9	0.771	171.9
1.45	0.954	166.2	1.832	55.2	0.0143	37.4	0.770	171.7
1.50	0.953	165.5	1.779	53.9	0.0147	37.8	0.770	171.4
1.55	0.953	164.8	1.730	52.6	0.0151	37.4	0.769	171.1
1.60	0.952	164.1	1.683	51.3	0.0154	38.1	0.769	170.9
1.65	0.953	163.2	1.641	50.1	0.0158	37.7	0.769	170.6
1.70	0.952	162.6	1.598	48.9	0.0161	37.8	0.769	170.5
1.75	0.951	161.8	1.559	47.6	0.0164	37.9	0.769	170.3
1.80	0.952	161.0	1.517	46.4	0.0167	37.9	0.769	170.3
1.85	0.948	161.6	1.549	44.6	0.0178	37.5	0.760	167.3
1.90	0.947	160.9	1.521	43.3	0.0183	37.3	0.759	166.8
1.95	0.947	160.3	1.494	42.0	0.0189	37.2	0.757	166.4
2.00	0.945	159.5	1.470	40.7	0.0194	37.2	0.756	165.9
2.05	0.945	158.9	1.447	39.4	0.0198	36.9	0.754	165.6
2.10	0.945	158.1	1.426	38.0	0.0204	36.4	0.754	165.1
2.15	0.944	157.5	1.407	36.7	0.0209	36.4	0.752	164.7
2.20	0.943	156.8	1.389	35.4	0.0215	36.0	0.751	164.2
2.25	0.942	156.0	1.371	34.0	0.0220	35.9	0.749	163.8
2.30	0.941	155.2	1.355	32.7	0.0226	35.5	0.749	163.2
2.35	0.939	154.6	1.341	31.3	0.0234	34.9	0.745	162.9
2.40	0.939	153.8	1.328	29.9	0.0238	34.2	0.744	162.5
2.45	0.937	153.0	1.316	28.6	0.0245	34.3	0.742	162.1

(continued)

**Table 6. Class AB Common Source S-Parameters** ( $V_{DD} = 12 \text{ Vdc}$ ,  $I_{DQ} = 1000 \text{ mA}$ ,  $T_C = 25^\circ\text{C}$ , 50 ohm system) (continued)

f GHz	S <sub>11</sub>		S <sub>21</sub>		S <sub>12</sub>		S <sub>22</sub>	
	S <sub>11</sub>	∠φ	S <sub>21</sub>	∠φ	S <sub>12</sub>	∠φ	S <sub>22</sub>	∠φ
2.50	0.936	152.2	1.305	27.2	0.0250	33.8	0.740	161.6
2.55	0.935	151.4	1.296	25.8	0.0258	33.4	0.738	161.1
2.60	0.933	150.5	1.287	24.4	0.0264	32.7	0.737	160.7
2.65	0.933	149.8	1.279	23.0	0.0273	32.1	0.736	160.1
2.70	0.930	149.0	1.272	21.6	0.0280	31.7	0.733	159.7
2.75	0.929	148.1	1.266	20.1	0.0288	31.5	0.730	159.2
2.80	0.926	147.2	1.261	18.7	0.0297	30.6	0.728	158.7
2.85	0.925	146.3	1.257	17.2	0.0306	29.9	0.725	158.2
2.90	0.924	145.3	1.254	15.7	0.0314	29.2	0.722	157.7
2.95	0.921	144.4	1.251	14.2	0.0324	28.6	0.720	157.2
3.00	0.919	143.5	1.249	12.7	0.0333	27.8	0.717	156.7
3.05	0.916	142.5	1.249	11.2	0.0343	27.1	0.715	156.0
3.10	0.915	141.4	1.247	9.7	0.0355	26.3	0.710	155.7
3.15	0.912	140.5	1.249	8.1	0.0366	25.3	0.708	155.0
3.20	0.908	139.4	1.250	6.5	0.0377	24.7	0.705	154.5
3.25	0.905	138.3	1.252	4.9	0.0390	23.4	0.701	153.9
3.30	0.903	137.1	1.256	3.3	0.0400	22.2	0.698	153.4
3.35	0.899	136.0	1.260	1.6	0.0413	20.8	0.694	152.8
3.40	0.896	134.8	1.265	-0.1	0.0422	20.0	0.690	152.2
3.45	0.893	133.6	1.271	-1.8	0.0434	19.5	0.686	151.6
3.50	0.890	132.3	1.278	-3.5	0.0450	18.4	0.682	151.0
3.55	0.885	131.0	1.284	-5.3	0.0464	17.3	0.678	150.4
3.60	0.881	129.6	1.292	-7.1	0.0478	16.3	0.673	149.8
3.65	0.876	128.1	1.301	-9.0	0.0494	15.1	0.668	149.2
3.70	0.872	126.7	1.311	-10.8	0.0510	14.1	0.664	148.6
3.75	0.871	125.1	1.322	-12.7	0.0530	13.0	0.661	147.8
3.80	0.862	123.7	1.333	-14.7	0.0543	11.3	0.652	147.3
3.85	0.856	122.0	1.346	-16.6	0.0563	10.3	0.648	146.7
3.90	0.850	120.3	1.360	-18.6	0.0583	9.1	0.642	146.0
3.95	0.845	118.6	1.375	-20.7	0.0605	7.4	0.636	145.5
4.00	0.838	116.7	1.389	-22.9	0.0624	6.2	0.631	144.8
4.05	0.831	114.8	1.405	-25.0	0.0646	4.6	0.624	144.1
4.10	0.822	112.9	1.422	-27.3	0.0671	3.0	0.617	143.5
4.15	0.816	110.8	1.441	-29.6	0.0696	1.3	0.612	142.7
4.20	0.808	108.6	1.460	-31.9	0.0721	-0.4	0.605	142.1
4.25	0.801	106.4	1.480	-34.4	0.0747	-2.2	0.599	141.5
4.30	0.792	104.1	1.500	-36.9	0.0774	-4.0	0.591	140.7
4.35	0.783	101.6	1.523	-39.4	0.0804	-6.1	0.582	140.1
4.40	0.775	99.0	1.545	-42.1	0.0832	-8.1	0.576	139.5
4.45	0.765	96.2	1.567	-44.8	0.0861	-10.3	0.569	138.8
4.50	0.754	93.3	1.590	-47.7	0.0894	-12.4	0.561	138.1
4.55	0.743	90.2	1.611	-50.5	0.0924	-14.8	0.555	137.5
4.60	0.731	87.0	1.634	-53.5	0.0955	-17.0	0.547	136.8
4.65	0.718	83.8	1.659	-56.5	0.0989	-19.5	0.541	136.1

(continued)

**Table 6. Class AB Common Source S-Parameters** ( $V_{DD} = 12 \text{ Vdc}$ ,  $I_{DQ} = 1000 \text{ mA}$ ,  $T_C = 25^\circ\text{C}$ , 50 ohm system) (continued)

f GHz	S <sub>11</sub>		S <sub>21</sub>		S <sub>12</sub>		S <sub>22</sub>	
	S <sub>11</sub>	∠ φ	S <sub>21</sub>	∠ φ	S <sub>12</sub>	∠ φ	S <sub>22</sub>	∠ φ
4.70	0.706	80.3	1.683	-59.6	0.1025	-21.9	0.534	135.4
4.75	0.693	76.6	1.706	-62.7	0.1061	-24.5	0.526	134.6
4.80	0.680	72.8	1.729	-66.0	0.1097	-27.2	0.519	133.9
4.85	0.667	68.8	1.752	-69.4	0.1136	-30.0	0.512	133.0
4.90	0.655	64.6	1.775	-72.8	0.1175	-32.8	0.504	132.1
4.95	0.642	60.1	1.797	-76.3	0.1214	-35.8	0.496	131.3
5.00	0.630	55.5	1.819	-79.9	0.1254	-39.0	0.489	130.3
5.05	0.618	50.6	1.839	-83.6	0.1294	-42.2	0.481	129.2
5.10	0.608	45.5	1.859	-87.4	0.1335	-45.5	0.474	128.1
5.15	0.598	40.2	1.878	-91.2	0.1377	-49.1	0.467	126.7
5.20	0.591	34.5	1.896	-95.2	0.1412	-52.7	0.459	125.1
5.25	0.583	28.8	1.910	-99.3	0.1451	-56.2	0.450	123.6
5.30	0.579	22.7	1.924	-103.4	0.1488	-60.1	0.441	121.7
5.35	0.576	16.5	1.937	-107.7	0.1526	-63.9	0.431	119.6
5.40	0.576	10.1	1.947	-112.0	0.1561	-67.9	0.421	117.2
5.45	0.576	3.5	1.952	-116.5	0.1594	-72.0	0.410	114.6
5.50	0.580	-3.2	1.957	-121.2	0.1627	-76.3	0.397	111.4
5.55	0.585	-9.7	1.953	-125.8	0.1651	-80.6	0.383	108.1
5.60	0.592	-16.2	1.943	-130.5	0.1675	-85.0	0.368	104.2
5.65	0.601	-22.7	1.929	-135.3	0.1691	-89.5	0.350	99.8
5.70	0.613	-28.8	1.913	-139.9	0.1707	-93.8	0.331	95.1
5.75	0.627	-34.6	1.900	-144.6	0.1724	-98.2	0.312	89.6
5.80	0.646	-40.5	1.885	-149.5	0.1739	-102.8	0.292	83.2
5.85	0.667	-46.4	1.864	-154.6	0.1749	-107.5	0.272	75.6
5.90	0.688	-52.2	1.834	-159.8	0.1753	-112.4	0.251	66.6
5.95	0.708	-57.7	1.800	-164.9	0.1750	-117.3	0.232	56.0
6.00	0.730	-63.0	1.760	-170.1	0.1740	-122.2	0.215	43.8
6.05	0.751	-68.2	1.716	-175.2	0.1728	-127.1	0.204	29.6
6.10	0.772	-73.1	1.668	179.7	0.1709	-132.1	0.200	14.1
6.15	0.793	-77.7	1.617	174.6	0.1685	-136.9	0.204	-1.8
6.20	0.812	-82.3	1.561	169.6	0.1654	-141.9	0.218	-16.7
6.25	0.831	-86.6	1.504	164.6	0.1620	-146.8	0.240	-30.5
6.30	0.850	-90.8	1.445	159.6	0.1584	-151.5	0.268	-42.5
6.35	0.866	-94.8	1.385	154.7	0.1542	-156.4	0.299	-52.6
6.40	0.881	-98.7	1.323	150.0	0.1498	-161.0	0.335	-61.5
6.45	0.896	-102.3	1.261	145.3	0.1447	-165.4	0.371	-69.3
6.50	0.908	-105.9	1.199	140.7	0.1399	-169.7	0.407	-76.1
6.55	0.920	-109.2	1.138	136.3	0.1351	-173.9	0.444	-82.4
6.60	0.930	-112.4	1.077	132.0	0.1303	-178.1	0.479	-88.0
6.65	0.938	-115.4	1.018	127.8	0.1254	177.8	0.513	-93.1
6.70	0.946	-118.3	0.961	123.8	0.1202	173.9	0.547	-97.9
6.75	0.953	-121.0	0.906	119.8	0.1153	170.0	0.579	-102.3
6.80	0.959	-123.7	0.853	116.0	0.1103	166.4	0.608	-106.4
6.85	0.967	-126.4	0.802	112.2	0.1056	162.8	0.637	-110.2

(continued)

**Table 6. Class AB Common Source S-Parameters** ( $V_{DD} = 12 \text{ Vdc}$ ,  $I_{DQ} = 1000 \text{ mA}$ ,  $T_C = 25^\circ\text{C}$ , 50 ohm system) (continued)

f GHz	S <sub>11</sub>		S <sub>21</sub>		S <sub>12</sub>		S <sub>22</sub>	
	S <sub>11</sub>	∠φ	S <sub>21</sub>	∠φ	S <sub>12</sub>	∠φ	S <sub>22</sub>	∠φ
6.90	0.969	-128.8	0.752	108.7	0.1006	159.3	0.662	-113.9
6.95	0.971	-131.2	0.704	105.4	0.0959	156.2	0.686	-117.2
7.00	0.972	-133.4	0.660	102.3	0.0915	153.2	0.709	-120.4
7.05	0.973	-135.4	0.620	99.4	0.0874	150.3	0.729	-123.3
7.10	0.974	-137.3	0.582	96.5	0.0834	147.6	0.749	-126.0
7.15	0.974	-139.2	0.547	93.7	0.0795	145.0	0.769	-128.7
7.20	0.975	-140.9	0.513	91.0	0.0760	142.4	0.786	-131.3
7.25	0.976	-142.6	0.482	88.4	0.0726	140.0	0.802	-133.7
7.30	0.976	-144.3	0.453	85.9	0.0694	137.7	0.817	-136.0
7.35	0.977	-145.8	0.426	83.5	0.0665	135.2	0.830	-138.2
7.40	0.978	-147.3	0.400	81.1	0.0633	133.0	0.843	-140.2
7.45	0.977	-148.8	0.376	78.9	0.0605	131.0	0.856	-142.2
7.50	0.975	-150.0	0.354	76.8	0.0577	129.4	0.866	-144.1
7.55	0.975	-151.4	0.332	74.8	0.0553	127.8	0.878	-146.0
7.60	0.975	-152.6	0.313	72.9	0.0531	125.9	0.888	-147.8
7.65	0.974	-153.7	0.295	71.1	0.0511	124.2	0.897	-149.6
7.70	0.976	-154.7	0.278	69.4	0.0492	123.0	0.906	-151.2
7.75	0.979	-155.7	0.263	67.7	0.0475	121.1	0.913	-152.8
7.80	0.983	-156.8	0.249	66.0	0.0459	119.0	0.918	-154.4
7.85	0.986	-158.0	0.235	64.3	0.0438	117.2	0.925	-155.8
7.90	0.986	-159.1	0.222	62.7	0.0421	115.6	0.931	-157.1
7.95	0.984	-160.2	0.210	61.0	0.0404	113.5	0.937	-158.4
8.00	0.983	-161.2	0.199	59.4	0.0387	111.8	0.944	-159.7

**Table 7. Class AB Common Source S-Parameters** ( $V_{DD} = 12 \text{ Vdc}$ ,  $I_{DQ} = 140 \text{ mA}$ ,  $T_C = 25^\circ\text{C}$ , 50 ohm system)

f GHz	S <sub>11</sub>		S <sub>21</sub>		S <sub>12</sub>		S <sub>22</sub>	
	S <sub>11</sub>	∠ φ	S <sub>21</sub>	∠ φ	S <sub>12</sub>	∠ φ	S <sub>22</sub>	∠ φ
0.25	0.937	-166.5	8.882	91.6	0.0167	9.9	0.755	-175.6
0.30	0.936	-169.5	7.414	89.0	0.0166	8.8	0.757	-176.8
0.35	0.934	-171.9	6.373	86.6	0.0168	8.1	0.760	-177.8
0.40	0.937	-173.9	5.598	84.7	0.0170	7.7	0.760	-178.5
0.45	0.937	-175.5	4.983	82.8	0.0170	7.7	0.760	-179.2
0.50	0.936	-176.9	4.497	81.0	0.0169	7.6	0.761	-179.8
0.55	0.937	-178.2	4.098	79.3	0.0172	7.7	0.761	179.7
0.60	0.936	-179.2	3.765	77.7	0.0171	8.0	0.761	179.2
0.65	0.936	179.7	3.481	76.1	0.0172	7.7	0.761	178.7
0.70	0.936	178.8	3.241	74.6	0.0174	8.0	0.762	178.3
0.75	0.936	177.9	3.031	73.1	0.0173	7.9	0.762	177.9
0.80	0.936	177.0	2.849	71.6	0.0174	8.0	0.761	177.5
0.85	0.936	176.2	2.690	70.2	0.0176	8.6	0.761	177.2
0.90	0.935	175.4	2.548	68.7	0.0177	8.7	0.762	176.9
0.95	0.936	174.7	2.420	67.3	0.0177	8.9	0.761	176.5
1.00	0.935	173.9	2.307	65.9	0.0179	9.1	0.761	176.1
1.05	0.936	173.2	2.206	64.5	0.0181	9.1	0.761	175.8
1.10	0.934	172.6	2.111	63.1	0.0181	9.1	0.761	175.5
1.15	0.934	171.8	2.028	61.7	0.0183	9.4	0.761	175.1
1.20	0.934	171.1	1.949	60.3	0.0184	9.1	0.761	174.8
1.25	0.934	170.4	1.879	59.0	0.0186	9.4	0.762	174.5
1.30	0.934	169.7	1.814	57.6	0.0187	9.6	0.761	174.1
1.35	0.933	169.1	1.755	56.2	0.0188	9.7	0.762	173.8
1.40	0.933	168.4	1.700	54.9	0.0189	9.8	0.762	173.5
1.45	0.933	167.7	1.647	53.5	0.0192	10.0	0.762	173.2
1.50	0.932	167.1	1.598	52.2	0.0194	10.2	0.761	172.9
1.55	0.932	166.4	1.554	50.8	0.0195	10.0	0.761	172.7
1.60	0.932	165.7	1.510	49.5	0.0196	10.2	0.761	172.5
1.65	0.932	164.8	1.472	48.1	0.0198	10.2	0.762	172.2
1.70	0.931	164.1	1.432	46.8	0.0199	10.2	0.762	172.1
1.75	0.931	163.4	1.395	45.5	0.0201	10.3	0.763	171.9
1.80	0.931	162.6	1.357	44.3	0.0202	10.4	0.763	171.9
1.85	0.927	163.2	1.383	42.5	0.0212	10.0	0.755	169.0
1.90	0.926	162.6	1.357	41.2	0.0215	10.0	0.754	168.5
1.95	0.926	162.0	1.332	39.8	0.0216	10.2	0.753	168.1
2.00	0.925	161.2	1.309	38.4	0.0221	10.2	0.752	167.7
2.05	0.925	160.6	1.287	37.1	0.0224	10.0	0.752	167.3
2.10	0.924	159.9	1.267	35.7	0.0226	10.0	0.751	166.9
2.15	0.923	159.3	1.250	34.4	0.0230	10.0	0.751	166.5
2.20	0.923	158.6	1.232	33.0	0.0234	9.8	0.750	166.0
2.25	0.922	157.9	1.215	31.6	0.0236	9.9	0.749	165.6
2.30	0.921	157.1	1.200	30.2	0.0241	9.6	0.749	165.0
2.35	0.919	156.5	1.186	28.9	0.0246	9.3	0.746	164.7
2.40	0.919	155.7	1.173	27.5	0.0249	9.1	0.746	164.3
2.45	0.917	154.9	1.162	26.1	0.0254	9.3	0.744	163.9

(continued)

**Table 7. Class AB Common Source S-Parameters** ( $V_{DD} = 12 \text{ Vdc}$ ,  $I_{DQ} = 140 \text{ mA}$ ,  $T_C = 25^\circ\text{C}$ , 50 ohm system) (continued)

f GHz	S <sub>11</sub>		S <sub>21</sub>		S <sub>12</sub>		S <sub>22</sub>	
	S <sub>11</sub>	∠φ	S <sub>21</sub>	∠φ	S <sub>12</sub>	∠φ	S <sub>22</sub>	∠φ
2.50	0.917	154.2	1.151	24.7	0.0256	8.8	0.743	163.4
2.55	0.916	153.5	1.141	23.3	0.0262	8.8	0.742	163.0
2.60	0.914	152.6	1.132	21.9	0.0267	8.6	0.741	162.6
2.65	0.914	151.9	1.124	20.4	0.0272	8.2	0.740	162.0
2.70	0.911	151.1	1.116	19.0	0.0277	8.0	0.739	161.6
2.75	0.910	150.3	1.111	17.6	0.0282	8.1	0.736	161.0
2.80	0.908	149.5	1.104	16.1	0.0290	7.7	0.735	160.6
2.85	0.907	148.6	1.100	14.7	0.0296	7.3	0.733	160.1
2.90	0.906	147.7	1.096	13.2	0.0302	7.1	0.731	159.5
2.95	0.903	146.8	1.092	11.7	0.0310	6.6	0.729	159.0
3.00	0.901	145.9	1.089	10.2	0.0317	6.4	0.727	158.5
3.05	0.899	145.0	1.088	8.7	0.0324	5.8	0.725	157.9
3.10	0.898	143.9	1.085	7.2	0.0333	5.3	0.722	157.6
3.15	0.895	143.1	1.086	5.6	0.0340	4.9	0.721	156.8
3.20	0.892	142.0	1.086	4.1	0.0350	4.5	0.719	156.3
3.25	0.889	141.0	1.087	2.5	0.0361	3.8	0.716	155.8
3.30	0.887	139.9	1.089	0.9	0.0371	2.7	0.713	155.2
3.35	0.884	138.9	1.092	-0.7	0.0379	1.9	0.711	154.6
3.40	0.881	137.8	1.095	-2.4	0.0386	0.9	0.708	154.0
3.45	0.879	136.6	1.099	-4.0	0.0394	0.9	0.705	153.4
3.50	0.876	135.4	1.104	-5.7	0.0406	0.3	0.702	152.8
3.55	0.872	134.1	1.109	-7.4	0.0418	-0.6	0.698	152.2
3.60	0.868	132.8	1.115	-9.2	0.0429	-1.4	0.695	151.5
3.65	0.864	131.5	1.121	-11.0	0.0440	-2.2	0.691	150.9
3.70	0.860	130.1	1.129	-12.7	0.0452	-2.9	0.688	150.2
3.75	0.860	128.6	1.138	-14.6	0.0468	-3.6	0.686	149.5
3.80	0.852	127.3	1.147	-16.5	0.0480	-5.0	0.679	148.9
3.85	0.846	125.7	1.157	-18.4	0.0494	-5.8	0.675	148.2
3.90	0.841	124.2	1.168	-20.3	0.0509	-6.4	0.670	147.5
3.95	0.837	122.6	1.181	-22.3	0.0528	-7.8	0.666	146.8
4.00	0.830	120.8	1.192	-24.3	0.0543	-8.7	0.661	146.1
4.05	0.825	119.0	1.206	-26.4	0.0560	-9.9	0.656	145.3
4.10	0.817	117.3	1.220	-28.5	0.0580	-11.0	0.650	144.7
4.15	0.812	115.3	1.236	-30.7	0.0600	-12.2	0.646	143.8
4.20	0.805	113.3	1.252	-33.0	0.0621	-13.5	0.641	143.0
4.25	0.799	111.3	1.270	-35.2	0.0643	-15.0	0.635	142.2
4.30	0.791	109.0	1.288	-37.7	0.0665	-16.6	0.628	141.3
4.35	0.783	106.7	1.308	-40.1	0.0690	-18.1	0.621	140.6
4.40	0.777	104.3	1.328	-42.6	0.0714	-19.8	0.615	139.8
4.45	0.769	101.7	1.347	-45.2	0.0739	-21.5	0.609	138.9
4.50	0.759	98.9	1.370	-47.9	0.0766	-23.4	0.602	138.1
4.55	0.749	96.0	1.390	-50.6	0.0792	-25.3	0.596	137.2
4.60	0.738	93.1	1.412	-53.5	0.0819	-27.3	0.589	136.3
4.65	0.727	90.1	1.436	-56.4	0.0849	-29.5	0.583	135.3

(continued)

**Table 7. Class AB Common Source S-Parameters** ( $V_{DD} = 12 \text{ Vdc}$ ,  $I_{DQ} = 140 \text{ mA}$ ,  $T_C = 25^\circ\text{C}$ , 50 ohm system) (continued)

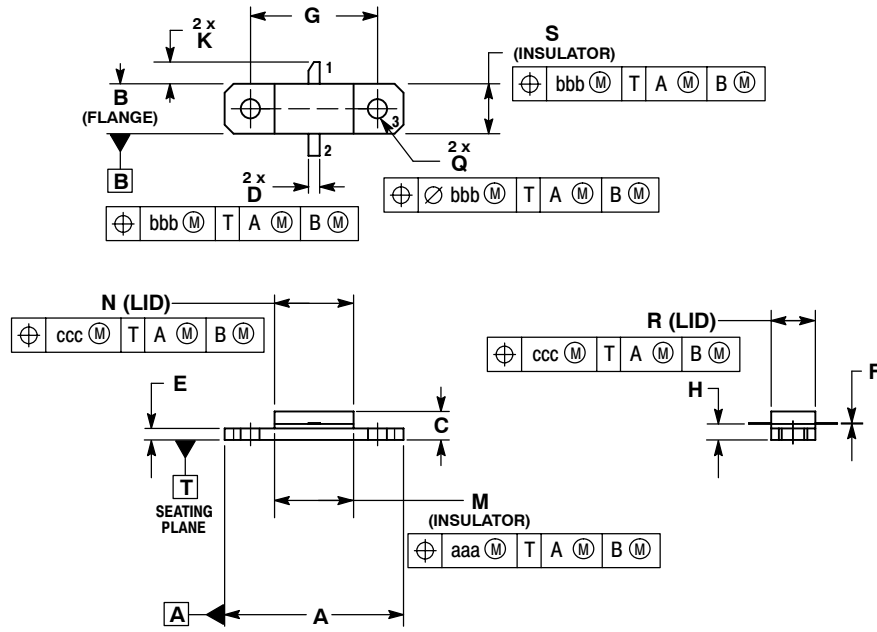
f GHz	S <sub>11</sub>		S <sub>21</sub>		S <sub>12</sub>		S <sub>22</sub>	
	S <sub>11</sub>	∠ φ	S <sub>21</sub>	∠ φ	S <sub>12</sub>	∠ φ	S <sub>22</sub>	∠ φ
4.70	0.717	86.7	1.459	-59.3	0.0880	-31.6	0.576	134.4
4.75	0.705	83.2	1.482	-62.4	0.0913	-33.8	0.568	133.4
4.80	0.693	79.6	1.505	-65.6	0.0945	-36.1	0.560	132.3
4.85	0.682	75.8	1.530	-68.8	0.0977	-38.6	0.553	131.2
4.90	0.670	71.7	1.554	-72.2	0.1016	-41.2	0.544	130.0
4.95	0.658	67.4	1.578	-75.6	0.1051	-43.8	0.536	128.9
5.00	0.647	62.9	1.602	-79.2	0.1089	-46.6	0.527	127.6
5.05	0.636	58.1	1.626	-82.8	0.1127	-49.6	0.519	126.2
5.10	0.625	53.1	1.649	-86.6	0.1167	-52.7	0.510	124.8
5.15	0.615	47.9	1.672	-90.4	0.1207	-56.1	0.502	123.1
5.20	0.607	42.3	1.694	-94.4	0.1244	-59.5	0.492	121.3
5.25	0.599	36.5	1.713	-98.5	0.1281	-62.9	0.482	119.4
5.30	0.594	30.4	1.731	-102.7	0.1319	-66.6	0.471	117.2
5.35	0.590	24.0	1.750	-107.0	0.1357	-70.3	0.460	114.9
5.40	0.589	17.5	1.764	-111.4	0.1392	-74.2	0.449	112.3
5.45	0.588	10.7	1.776	-116.0	0.1428	-78.2	0.436	109.4
5.50	0.590	3.7	1.785	-120.8	0.1461	-82.6	0.423	106.0
5.55	0.593	-3.2	1.787	-125.6	0.1488	-86.7	0.407	102.4
5.60	0.598	-10.1	1.784	-130.4	0.1514	-91.0	0.392	98.2
5.65	0.605	-17.0	1.777	-135.3	0.1533	-95.6	0.373	93.6
5.70	0.616	-23.5	1.767	-140.2	0.1551	-100.0	0.354	88.4
5.75	0.629	-29.8	1.757	-145.1	0.1571	-104.5	0.334	82.7
5.80	0.648	-36.1	1.744	-150.3	0.1584	-109.1	0.314	76.0
5.85	0.668	-42.5	1.724	-155.6	0.1596	-113.9	0.294	68.3
5.90	0.687	-48.8	1.697	-160.9	0.1599	-118.7	0.275	59.4
5.95	0.706	-54.8	1.664	-166.2	0.1597	-123.7	0.257	49.1
6.00	0.726	-60.5	1.627	-171.5	0.1589	-128.5	0.243	37.5
6.05	0.746	-66.1	1.587	-176.8	0.1578	-133.4	0.234	24.5
6.10	0.766	-71.3	1.542	178.0	0.1562	-138.3	0.231	10.5
6.15	0.785	-76.3	1.494	172.8	0.1542	-143.2	0.236	-3.7
6.20	0.803	-81.1	1.441	167.6	0.1515	-148.1	0.249	-17.1
6.25	0.820	-85.6	1.388	162.4	0.1484	-153.0	0.269	-29.9
6.30	0.838	-90.0	1.332	157.3	0.1450	-157.8	0.293	-41.1
6.35	0.853	-94.2	1.274	152.3	0.1410	-162.5	0.322	-51.0
6.40	0.867	-98.2	1.216	147.5	0.1368	-167.0	0.355	-59.8
6.45	0.880	-102.0	1.157	142.7	0.1323	-171.3	0.388	-67.7
6.50	0.892	-105.6	1.099	138.0	0.1280	-175.6	0.423	-74.6
6.55	0.902	-109.0	1.041	133.5	0.1236	-179.7	0.457	-81.0
6.60	0.911	-112.2	0.985	129.2	0.1193	176.3	0.490	-86.7
6.65	0.918	-115.3	0.929	125.0	0.1149	172.1	0.523	-91.9
6.70	0.926	-118.2	0.876	120.9	0.1102	168.3	0.555	-96.8
6.75	0.933	-121.0	0.825	116.9	0.1058	164.6	0.585	-101.4
6.80	0.938	-123.7	0.777	112.9	0.1012	161.0	0.613	-105.6
6.85	0.946	-126.3	0.729	109.2	0.0968	157.4	0.641	-109.5

(continued)

**Table 7. Class AB Common Source S-Parameters** ( $V_{DD} = 12 \text{ Vdc}$ ,  $I_{DQ} = 140 \text{ mA}$ ,  $T_C = 25^\circ\text{C}$ , 50 ohm system) (continued)

f GHz	S <sub>11</sub>		S <sub>21</sub>		S <sub>12</sub>		S <sub>22</sub>	
	S <sub>11</sub>	∠φ	S <sub>21</sub>	∠φ	S <sub>12</sub>	∠φ	S <sub>22</sub>	∠φ
6.90	0.948	-128.8	0.684	105.6	0.0930	154.1	0.665	-113.3
6.95	0.950	-131.1	0.638	102.3	0.0882	151.3	0.688	-116.7
7.00	0.952	-133.3	0.598	99.2	0.0843	148.5	0.711	-119.9
7.05	0.953	-135.3	0.561	96.2	0.0805	145.7	0.730	-122.8
7.10	0.953	-137.2	0.526	93.3	0.0771	142.9	0.750	-125.6
7.15	0.954	-139.1	0.493	90.4	0.0738	140.2	0.770	-128.3
7.20	0.956	-140.8	0.462	87.7	0.0701	137.8	0.786	-131.0
7.25	0.957	-142.4	0.434	85.1	0.0672	135.5	0.802	-133.4
7.30	0.958	-144.1	0.407	82.7	0.0645	133.4	0.817	-135.7
7.35	0.959	-145.5	0.382	80.3	0.0617	130.8	0.831	-138.0
7.40	0.961	-147.0	0.359	77.9	0.0589	128.7	0.843	-140.0
7.45	0.961	-148.5	0.337	75.7	0.0561	126.6	0.855	-141.9
7.50	0.959	-149.8	0.316	73.6	0.0535	125.1	0.865	-143.8
7.55	0.960	-151.1	0.297	71.6	0.0515	123.7	0.877	-145.8
7.60	0.960	-152.3	0.279	69.8	0.0496	122.1	0.887	-147.6
7.65	0.960	-153.4	0.263	67.9	0.0476	120.3	0.895	-149.4
7.70	0.962	-154.4	0.247	66.3	0.0459	118.9	0.905	-151.0
7.75	0.967	-155.4	0.234	64.8	0.0446	117.2	0.912	-152.6
7.80	0.970	-156.6	0.221	63.0	0.0430	115.2	0.917	-154.2
7.85	0.974	-157.8	0.209	61.4	0.0414	113.5	0.923	-155.6
7.90	0.975	-158.9	0.198	59.7	0.0397	111.3	0.928	-156.9
7.95	0.973	-159.9	0.186	58.0	0.0379	109.5	0.934	-158.3
8.00	0.973	-161.0	0.176	56.5	0.0360	108.7	0.941	-159.5

## PACKAGE DIMENSIONS



### NOTES:

1. CONTROLLING DIMENSION: INCH.
2. INTERPRET DIMENSIONS AND TOLERANCES PER ASME Y14.5M-1994.
3. DIMENSION H IS MEASURED .030 (0.762) AWAY FROM PACKAGE BODY.

DIM	INCHES		MILLIMETERS	
	MIN	MAX	MIN	MAX
A	.795	.805	20.19	20.45
B	.225	.235	5.72	5.97
C	.125	.176	3.18	4.47
D	.034	.044	0.89	1.12
E	.055	.065	1.40	1.65
F	.004	.006	0.10	0.15
G	.562 BSC		14.28 BSC	
H	.077	.087	1.96	2.21
K	.085	.115	2.16	2.92
M	.355	.365	9.02	9.27
N	.355	.365	9.96	10.16
Q	.125	.135	3.18	3.43
R	.225	.235	5.72	5.97
S	.225	.235	5.72	5.97
aaa	.005		0.13	
bbb	.010		0.25	
ccc	.015		0.38	

### STYLE 1:

- PIN 1. GATE
- DRAIN
- SOURCE

**CASE 360D-02  
ISSUE C  
NI-360HF**

## PRODUCT DOCUMENTATION

Refer to the following documents to aid your design process.

### Application Notes

- AN1955: Thermal Measurement Methodology of RF Power Amplifiers

## REVISION HISTORY

The following table summarizes revisions to this document.

Revision	Date	Description
0	May 2006	<ul style="list-style-type: none"> <li>• Initial Release of Data Sheet</li> </ul>
1	June 2006	<ul style="list-style-type: none"> <li>• Removed R5 suffix from part number and Tape and Reel info, p. 1</li> </ul>
2	Dec. 2008	<ul style="list-style-type: none"> <li>• Changed Storage Temperature Range in Max Ratings table from -65 to +175 to -65 to +150 for standardization across products, p. 1</li> <li>• Removed "Operating Case Temperature Range" from Maximum Ratings table so that the maximum channel temperature rating is the limiting thermal design criteria and not the case temperature range, p. 1</li> <li>• Added Table 3, ESD Protection Characteristics, p. 1; renumbered subsequent tables</li> </ul>

## **How to Reach Us:**

### **Home Page:**

[www.freescale.com](http://www.freescale.com)

### **Web Support:**

<http://www.freescale.com/support>

### **USA/Europe or Locations Not Listed:**

Freescale Semiconductor, Inc.  
Technical Information Center, EL516  
2100 East Elliot Road  
Tempe, Arizona 85284  
1-800-521-6274 or +1-480-768-2130  
[www.freescale.com/support](http://www.freescale.com/support)

### **Europe, Middle East, and Africa:**

Freescale Halbleiter Deutschland GmbH  
Technical Information Center  
Schatzbogen 7  
81829 Muenchen, Germany  
+44 1296 380 456 (English)  
+46 8 52200080 (English)  
+49 89 92103 559 (German)  
+33 1 69 35 48 48 (French)  
[www.freescale.com/support](http://www.freescale.com/support)

### **Japan:**

Freescale Semiconductor Japan Ltd.  
Headquarters  
ARCO Tower 15F  
1-8-1, Shimo-Meguro, Meguro-ku,  
Tokyo 153-0064  
Japan  
0120 191014 or +81 3 5437 9125  
[support.japan@freescale.com](mailto:support.japan@freescale.com)

### **Asia/Pacific:**

Freescale Semiconductor China Ltd.  
Exchange Building 23F  
No. 118 Jianguo Road  
Chaoyang District  
Beijing 100022  
China  
+86 10 5879 8000  
[support.asia@freescale.com](mailto:support.asia@freescale.com)

### **For Literature Requests Only:**

Freescale Semiconductor Literature Distribution Center  
P.O. Box 5405  
Denver, Colorado 80217  
1-800-441-2447 or +1-303-675-2140  
Fax: +1-303-675-2150  
[LDCForFreescaleSemiconductor@hibbertgroup.com](mailto:LDCForFreescaleSemiconductor@hibbertgroup.com)

Information in this document is provided solely to enable system and software implementers to use Freescale Semiconductor products. There are no express or implied copyright licenses granted hereunder to design or fabricate any integrated circuits or integrated circuits based on the information in this document.

Freescale Semiconductor reserves the right to make changes without further notice to any products herein. Freescale Semiconductor makes no warranty, representation or guarantee regarding the suitability of its products for any particular purpose, nor does Freescale Semiconductor assume any liability arising out of the application or use of any product or circuit, and specifically disclaims any and all liability, including without limitation consequential or incidental damages. "Typical" parameters that may be provided in Freescale Semiconductor data sheets and/or specifications can and do vary in different applications and actual performance may vary over time. All operating parameters, including "Typicals", must be validated for each customer application by customer's technical experts. Freescale Semiconductor does not convey any license under its patent rights nor the rights of others. Freescale Semiconductor products are not designed, intended, or authorized for use as components in systems intended for surgical implant into the body, or other applications intended to support or sustain life, or for any other application in which the failure of the Freescale Semiconductor product could create a situation where personal injury or death may occur. Should Buyer purchase or use Freescale Semiconductor products for any such unintended or unauthorized application, Buyer shall indemnify and hold Freescale Semiconductor and its officers, employees, subsidiaries, affiliates, and distributors harmless against all claims, costs, damages, and expenses, and reasonable attorney fees arising out of, directly or indirectly, any claim of personal injury or death associated with such unintended or unauthorized use, even if such claim alleges that Freescale Semiconductor was negligent regarding the design or manufacture of the part.

Freescale™ and the Freescale logo are trademarks of Freescale Semiconductor, Inc. All other product or service names are the property of their respective owners.

© Freescale Semiconductor, Inc. 2006, 2008. All rights reserved.

## Looking for pricing, stock, or lifecycle information?

Click below to explore more details on WIN SOURCE:

 [View MRFG35010AR1 on WIN SOURCE](#)

 [NXP / Nexperia Information](#)

## Optimize Your Supply Chain with WIN SOURCE Solutions

-  Global Sourcing Solution
-  Obsolete Management
-  Cost Control Management
-  Shortage Management
-  Alternative Solution
-  Excess Inventory Management