



**THE DATASHEET OF
NTE74LS04**





ELECTRONICS, INC.
 44 FARRAND STREET
 BLOOMFIELD, NJ 07003
 (973) 748-5089
<http://www.nteinc.com>

NTE74LS04 Integrated Circuit TTL – Hex Inverter

Description:

The NTE74LS04 contains six independent inverters in a 14-Lead plastic DIP type package.

Absolute Maximum Ratings: (Note 1)

Supply Voltage, V_{CC}	7V
DC Input Voltage, V_{IN}	7V
Operating Temperature Range, T_A	0°C to +70°C
Storage Temperature Range, T_{stg}	-65°C to +150°C

Note 1. Unless otherwise specified, all voltages are referenced to GND.

Recommended Operating Conditions:

Parameter	Symbol	Min	Typ	Max	Unit
Supply Voltage	V_{CC}	4.75	5.0	5.25	V
High-Level Input Voltage	V_{IH}	2.0	-	-	V
Low-Level Input Voltage	V_{IL}	-	-	0.8	V
High-Level Output Current	I_{OH}	-	-	-0.4	mA
Low-Level Output Current	I_{OL}	-	-	8	mA
Operating Temperature Range	T_A	0	-	+70	°C

Electrical Characteristics: (Note 2, Note 3)

Parameter	Symbol	Test Conditions	Min	Typ	Max	Unit
Input Clamp Voltage	V_{IK}	$V_{CC} = \text{MIN}, I_I = -18\text{mA}$	-	-	-1.5	V
High Level Output Voltage	V_{OH}	$V_{CC} = \text{MIN}, V_{IL} = \text{MAX}, I_{OH} = -0.4\text{mA}$	2.7	3.4	-	V
Low Level Output Voltage	V_{OL}	$V_{CC} = \text{MIN}, V_{IH} = 2\text{V}, I_{OL} = 4\text{mA}$	-	-	0.4	V
		$V_{CC} = \text{MIN}, V_{IH} = 2\text{V}, I_{OL} = 8\text{mA}$	-	0.25	0.5	V
Input Current	I_I	$V_{CC} = \text{MAX}, V_I = 7\text{V}$	-	-	0.1	mA

Note 2. For conditions shown as MIN or MAX, use the appropriate value specified under “Recommended Operation Conditions”.

Note 3. All typical values are at $V_{CC} = 5\text{V}, T_A = +25^\circ\text{C}$.

Electrical Characteristics (Cont'd): (Note 2, Note 3)

Parameter	Symbol	Test Conditions	Min	Typ	Max	Unit
High Level Input Current	I_{IH}	$V_{CC} = \text{MAX}, V_I = 2.7\text{V}$	-	-	20	μA
Low Level Input Current	I_{IL}	$V_{CC} = \text{MAX}, V_I = 0.4\text{V}$	-	-	-0.4	mA
Short-Circuit Output Current	I_{OS}	$V_{CC} = \text{MAX}, \text{Note 4}$	-20	-	-100	mA
High Level Supply Current	I_{CCH}	$V_{CC} = \text{MAX}, V_I = 0$	-	1.2	2.4	mA
Low Level Supply Current	I_{CCL}	$V_{CC} = \text{MAX}, V_I = 4.5\text{V}$	-	3.6	6.6	mA

Note 2. For conditions shown as MIN or MAX, use the appropriate value specified under "Recommended Operation Conditions".

Note 3. All typical values are at $V_{CC} = 5\text{V}, T_A = +25^\circ\text{C}$.

Note 4. Not more than one output should be shorted at a time, and the duration of the short-circuit should not exceed one second.

Switching Characteristics: ($V_{CC} = 5\text{V}, T_A = +25^\circ\text{C}$ unless otherwise specified)

Parameter	Symbol	Test Conditions	Min	Typ	Max	Unit
Propagation Delay Time From A Input to Y Output)	t_{PLH}	$R_L = 2\text{k}\Omega, C_L = 15\text{pF}$	-	9	15	ns
	t_{PHL}		-	10	15	ns

Function Table (Each Inverter):

Input	Output
A	Y
H	L
L	H

H = HIGH Voltage Level

L = LOW Voltage Level

Pin Connection Diagram

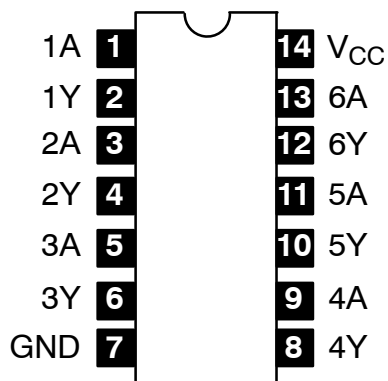

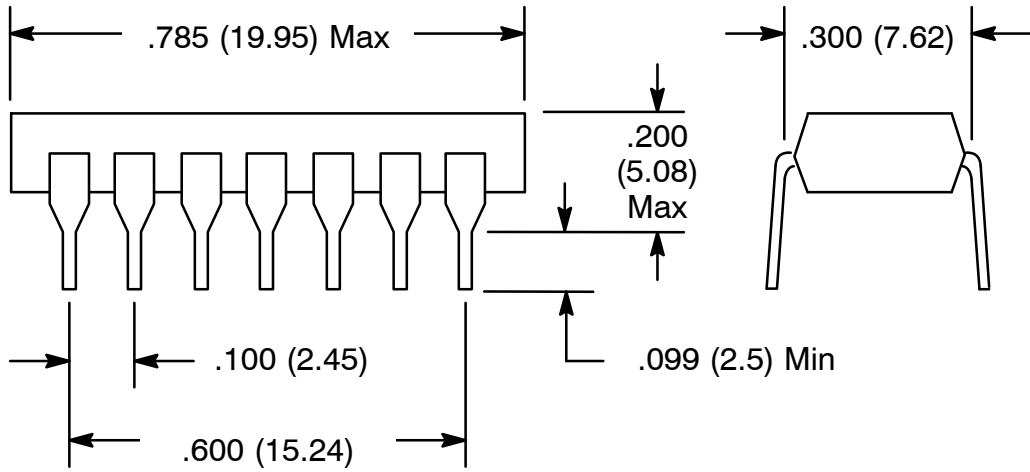
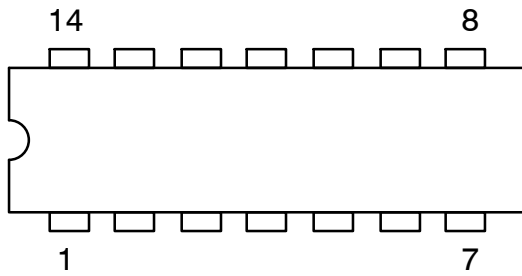

Looking for pricing, stock, or lifecycle information?

Click below to explore more details on WIN SOURCE:

 [View NTE74LS04 on WIN SOURCE](#)

 [NTE Information](#)

Optimize Your Supply Chain with WIN SOURCE Solutions

-  Global Sourcing Solution
-  Obsolete Management
-  Cost Control Management
-  Shortage Management
-  Alternative Solution
-  Excess Inventory Management