



**THE DATASHEET OF  
CXA3590-0000-000R00AD27F**



# XLamp® CXA3590 LED



## PRODUCT DESCRIPTION

The XLamp® CXA3590 LED array expands Cree LED's family of high-flux, multi-die integrated arrays, offering high performance in an easy-to-use platform. With XLamp LED lighting-class reliability, the CXA3590's uniform emitting surface enables both directional and non-directional lighting applications and luminaire and lamp designs. Available in 2-step, 3-step and 4-step color consistency, and featuring a 30-mm optical source, the CXA3590 brings new levels of flux and efficacy to this form factor.

The [CX Family LED Design Guide](#) provides basic information on the requirements to use the CXA3590 LED successfully in luminaire designs.

## FEATURES

- Available in 4-step, 3-step and 2-step EasyWhite® bins at 2700 K, 3000 K, 3500 K, 4000 K & 5000 K CCT and 4-step EasyWhite bins at 5700 K & 6500 K CCT
- Available in ANSI white bins at 5000 K, 5700 K & 6500 K CCT
- Available in 70-, 80-, 90- and 93-minimum CRI options
- Forward voltage options: 36-V class & 72-V class
- 85 °C binning and characterization
- Maximum drive current: 3600 mA (36 V), 1800 mA (72 V)
- 115° viewing angle, uniform chromaticity profile
- Top-side solder connections
- Thermocouple attach point
- NEMA SSL-3 2011 standard flux bins
- RoHS and REACH compliant
- UL® recognized component (E349212)

## TABLE OF CONTENTS

|   |    |
|---|----|
| Characteristics .....   | 2  |
| Operating Limits.....   | 3  |
| Flux Characteristics, EasyWhite® Order Codes and Bins - 36 V..... | 4  |
| Flux Characteristics, ANSI White Order Codes and Bins - 36 V..... | 7  |
| Flux Characteristics, EasyWhite® Order Codes and Bins - 72 V..... | 8  |
| Flux Characteristics, ANSI White Order Codes and Bins - 72 V..... | 11 |
| Relative Spectral Power Distribution .....                        | 12 |
| Electrical Characteristics.....                                   | 13 |
| Relative Luminous Flux.....                                       | 14 |
| Typical Spatial Distribution.....                                 | 16 |
| Performance Groups - Brightness .....                             | 16 |
| Performance Groups - Chromaticity .....                           | 17 |
| EasyWhite® Bins Plotted on the 1931 CIE Color Space .....         | 20 |
| ANSI White Bins Plotted on the 1931 CIE Color Space .....         | 20 |
| Bin and Order Code Formats.....                                   | 21 |
| Mechanical Dimensions .....                                       | 21 |
| Thermal Design.....   | 22 |
| Notes .....   | 24 |
| Packaging.....  | 25 |



Cree LED / 4001 E. Hwy. 54, Suite 2000 / Durham, NC 27709 USA / +1.919.313.5330 / [www.cree-led.com](http://www.cree-led.com)

## CHARACTERISTICS

| Characteristics  | Unit    | Minimum | Typical | Maximum |
|--|---------|---------|---------|---------|
| Viewing angle (FWHM)   | degrees |         | 115     |         |
| ESD withstand voltage (HBM per Mil-Std-883D)                         | V       |         |         | 8000    |
| DC forward current (36 V)  | mA      |         |         | 3600*   |
| DC forward current (72 V)  | mA      |         |         | 1800*   |
| Reverse current (36 V, 72 V)   | mA      |         |         | 0.1     |
| Forward voltage (36 V, @ 2400 mA, $T_j = 85\text{ }^\circ\text{C}$ ) | V       |         | 36**    |         |
| Forward voltage (36 V, @ 2400 mA, $T_j = 25\text{ }^\circ\text{C}$ ) | V       |         |         | 41**    |
| Forward voltage (72 V, @ 1200 mA, $T_j = 85\text{ }^\circ\text{C}$ ) | V       |         | 72**    |         |
| Forward voltage (72 V, @ 1200 mA, $T_j = 25\text{ }^\circ\text{C}$ ) | V       |         |         | 81**    |

\* Refer to the Operating Limits section.

\*\* For CXA3590 LEDs having order codes with a CXA3590-xxxx-xxxN0xxxxxx or CXA3590-xxxx-xxxR0xxxxxx format, the forward voltage values are as follows:

| Characteristics  | Unit | Minimum | Typical | Maximum |
|--|------|---------|---------|---------|
| Forward voltage (36 V, @ 2400 mA, $T_j = 85\text{ }^\circ\text{C}$ ) | V    |         | 38.5    |         |
| Forward voltage (36 V, @ 2400 mA, $T_j = 25\text{ }^\circ\text{C}$ ) | V    |         |         | 42      |
| Forward voltage (72 V, @ 1200 mA, $T_j = 85\text{ }^\circ\text{C}$ ) | V    |         | 77      |         |
| Forward voltage (72 V, @ 1200 mA, $T_j = 25\text{ }^\circ\text{C}$ ) | V    |         |         | 84      |

**OPERATING LIMITS**

The maximum current rating of the CXA3590 depends on the case temperature ( $T_c$ ) when the LED has reached thermal equilibrium under steady-state operation. The graphs shown below assume that the system design employs good thermal management (thermal interface material and heat sink) and may vary when poor thermal management is employed. Please refer to the Mechanical Dimensions section on page 21 for the location of the  $T_c$  measurement point.

Another important factor in good thermal management is the temperature of the Light Emitting Surface (LES). Cree LED recommends a maximum LES temperature of 135 °C to ensure optimal LED lifetime. Please refer to the Thermal Design section on page 22 for more information on LES temperature measurement.

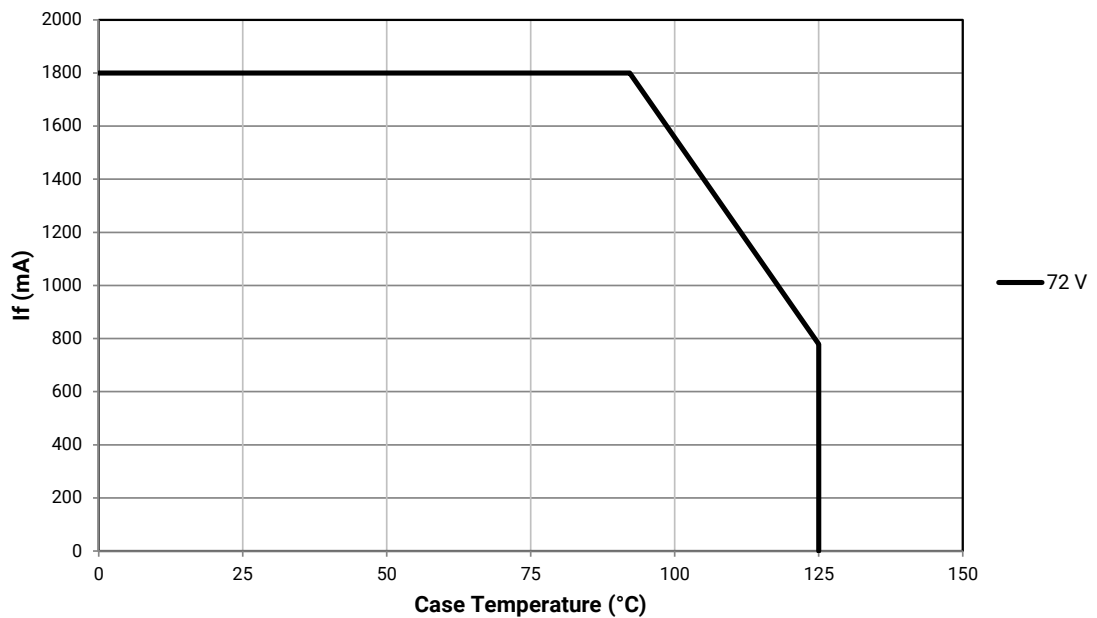
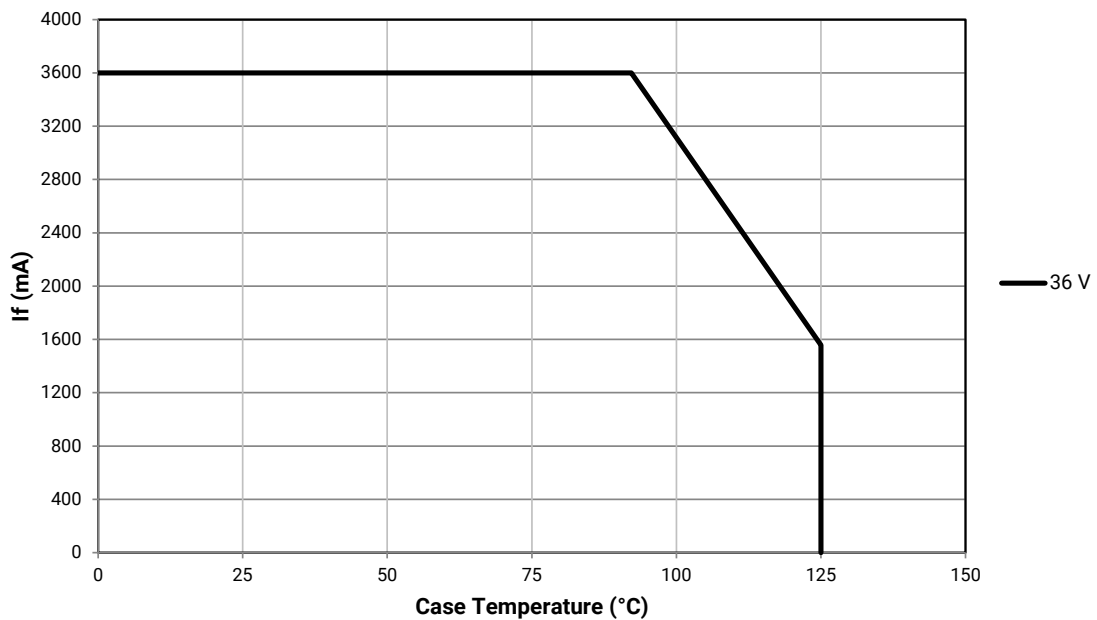

**FLUX CHARACTERISTICS, EASYWHITE® ORDER CODES AND BINS - 36 V (I<sub>F</sub> = 2400 mA, T<sub>J</sub> = 85 °C)**

The following table provides order codes for XLamp CXA3590 LEDs. For a complete description of the order code nomenclature, please see the Bin and Order Code Formats section (page 21).

| Nominal CCT | CRI |     | Minimum Luminous Flux |                   |                    | 2-Step |            | 3-Step |            | 4-Step |                          |
|-------------|-----|-----|-----------------------|-------------------|--------------------|--------|------------|--------|------------|--------|--------------------------|
|             | Min | Typ | Group                 | Flux (lm) @ 85 °C | Flux (lm) @ 25 °C* | Group  | Order Code | Group  | Order Code | Group  | Order Code               |
| 6500 K      | 70  | 75  | BD                    | 10,000            | 11,286             |        |            |        |            | 65F    | CXA3590-0000-000NT0BD65F |
|             |     |     | CB                    | 11,000            | 12,414             |        |            |        |            |        | CXA3590-0000-000NT0CB65F |
|             |     |     | CD                    | 12,000            | 13,543             |        |            |        |            |        | CXA3590-0000-000NT0CD65F |
|             | 80  | --- | BB                    | 9,500             | 10,721             |        |            |        |            | 65F    | CXA3590-0000-000NTHBB65F |
|             |     |     | BD                    | 10,000            | 11,286             |        |            |        |            |        | CXA3590-0000-000NTHBD65F |
|             |     |     | CB                    | 11,000            | 12,414             |        |            |        |            |        | CXA3590-0000-000NTHCB65F |
|             | 90  | 95  | Z4                    | 7,945             | 8,967              |        |            |        |            | 65F    | CXA3590-0000-000NTUZ465F |
|             |     |     | AB                    | 8,500             | 9,593              |        |            |        |            |        | CXA3590-0000-000NTUAB65F |
|             |     |     | AD                    | 9,000             | 10,157             |        |            |        |            |        | CXA3590-0000-000NTUAD65F |
| 5700 K      | 70  | 75  | BD                    | 10,000            | 11,286             |        |            |        |            | 57F    | CXA3590-0000-000NT0BD57F |
|             |     |     | CB                    | 11,000            | 12,414             |        |            |        |            |        | CXA3590-0000-000NT0CB57F |
|             |     |     | CD                    | 12,000            | 13,543             |        |            |        |            |        | CXA3590-0000-000NT0CD57F |
|             | 80  | --- | BB                    | 9,500             | 10,721             |        |            |        |            | 57F    | CXA3590-0000-000NTHBB57F |
|             |     |     | BD                    | 10,000            | 11,286             |        |            |        |            |        | CXA3590-0000-000NTHBD57F |
|             |     |     | CB                    | 11,000            | 12,414             |        |            |        |            |        | CXA3590-0000-000NTHCB57F |

- Notes
- Cree LED maintains a tolerance of ±7% on flux and power measurements, ±0.005 on chromaticity (CCx, CCy) measurements and a tolerance of ±2 on CRI measurements. See the Measurements section (page 24).
  - CXA3590 LED order codes specify only a minimum flux bin and not a maximum. Cree LED may ship reels in flux bins higher than the minimum specified by the order code without advance notice. Shipments will always adhere to the chromaticity bin restrictions specified by the order code.
  - \* Flux values @ 25 °C are calculated and for reference only.

**FLUX CHARACTERISTICS, EASYWHITE® ORDER CODES AND BINS - 36 V (I<sub>F</sub> = 2400 mA, T<sub>J</sub> = 85 °C) - CONTINUED**

| Nominal CCT | CRI    |     | Minimum Luminous Flux |                   |                    | 2-Step                   |                          | 3-Step                   |                          | 4-Step                   |                          |
|-------------|--------|-----|-----------------------|-------------------|--------------------|--------------------------|--------------------------|--------------------------|--------------------------|--------------------------|--------------------------|
|             | Min    | Typ | Group                 | Flux (lm) @ 85 °C | Flux (lm) @ 25 °C* | Group                    | Order Code               | Group                    | Order Code               | Group                    | Order Code               |
| 5000 K      | 70     | 75  | BD                    | 10,000            | 11,286             | 50H                      | CXA3590-0000-000NT0BD50H |                          |                          | 50F                      | CXA3590-0000-000NT0BD50F |
|             |        |     | CB                    | 11,000            | 12,414             |                          | CXA3590-0000-000NT0CB50H |                          |                          |                          | CXA3590-0000-000NT0CB50F |
|             |        |     | CD                    | 12,000            | 13,543             |                          | CXA3590-0000-000NT0CD50H |                          |                          |                          | CXA3590-0000-000NT0CD50F |
|             | 80     | --- | BB                    | 9,500             | 10,721             | 50H                      | CXA3590-0000-000NTHBB50H | 50G                      | CXA3590-0000-000NTHBB50G | 50F                      | CXA3590-0000-000NTHBB50F |
|             |        |     | BD                    | 10,000            | 11,286             |                          | CXA3590-0000-000NTHBD50H |                          | CXA3590-0000-000NTHBD50G |                          | CXA3590-0000-000NTHBD50F |
|             |        |     | CB                    | 11,000            | 12,414             |                          | CXA3590-0000-000NTHCB50H |                          | CXA3590-0000-000NTHCB50G |                          | CXA3590-0000-000NTHCB50F |
|             | 90     | 95  | AB                    | 8,500             | 9,593              | 50H                      | CXA3590-0000-000NTUAB50H | 50G                      | CXA3590-0000-000NTUAB50G | 50F                      | CXA3590-0000-000NTUAB50F |
|             |        |     | AD                    | 9,000             | 10,157             |                          | CXA3590-0000-000NTUAD50H |                          | CXA3590-0000-000NTUAD50G |                          | CXA3590-0000-000NTUAD50F |
|             | 4000 K | 70  | 75                    | BB                | 9,500              | 10,721                   | 40H                      | CXA3590-0000-000NT0BB40H |                          |                          | 40F                      |
| BD          |        |     |                       | 10,000            | 11,286             | CXA3590-0000-000NT0BD40H |                          | CXA3590-0000-000NT0BD40F |                          |                          |                          |
| CB          |        |     |                       | 11,000            | 12,414             | CXA3590-0000-000NT0CB40H |                          | CXA3590-0000-000NT0CB40F |                          |                          |                          |
| 80          |        | --- | AD                    | 9,000             | 10,157             | 40H                      | CXA3590-0000-000NTHAD40H | 40G                      | CXA3590-0000-000NTHAD40G | 40F                      | CXA3590-0000-000NTHAD40F |
|             |        |     | BB                    | 9,500             | 10,721             |                          | CXA3590-0000-000NTHBB40H |                          | CXA3590-0000-000NTHBB40G |                          | CXA3590-0000-000NTHBB40F |
|             |        |     | BD                    | 10,000            | 11,286             |                          | CXA3590-0000-000NTHBD40H |                          | CXA3590-0000-000NTHBD40G |                          | CXA3590-0000-000NTHBD40F |
| 90          |        | 95  | Z4                    | 7,945             | 8,967              | 40H                      | CXA3590-0000-000NTUZ440H | 40G                      | CXA3590-0000-000NTUZ440G | 40F                      | CXA3590-0000-000NTUZ440F |
|             |        |     | AB                    | 8,500             | 9,593              |                          | CXA3590-0000-000NTUAB40H |                          | CXA3590-0000-000NTUAB40G |                          | CXA3590-0000-000NTUAB40F |
| 3500 K      |        | 80  | ---                   | AD                | 9,000              | 10,157                   | 35H                      | CXA3590-0000-000NT0AD35H | 35G                      | CXA3590-0000-000NT0AD35G | 35F                      |
|             | BB     |     |                       | 9,500             | 10,721             | CXA3590-0000-000NT0BB35H |                          | CXA3590-0000-000NT0BB35G |                          | CXA3590-0000-000NT0BB35F |                          |
|             | BD     |     |                       | 10,000            | 11,286             | CXA3590-0000-000NT0BD35H |                          | CXA3590-0000-000NT0BD35G |                          | CXA3590-0000-000NT0BD35F |                          |
|             | 93     | 95  | Z2                    | 7,390             | 8,340              | 35H                      | CXA3590-0000-000NTYZ235H | 35G                      | CXA3590-0000-000NTYZ235G | 35F                      | CXA3590-0000-000NTYZ235F |
|             |        |     | Z4                    | 7,945             | 8,967              |                          | CXA3590-0000-000NTYZ435H |                          | CXA3590-0000-000NTYZ435G |                          | CXA3590-0000-000NTYZ435F |

- Notes**
- Cree LED maintains a tolerance of ±7% on flux and power measurements, ±0.005 on chromaticity (CCx, CCy) measurements and a tolerance of ±2 on CRI measurements. See the Measurements section (page 24).
  - CXA3590 LED order codes specify only a minimum flux bin and not a maximum. Cree LED may ship reels in flux bins higher than the minimum specified by the order code without advance notice. Shipments will always adhere to the chromaticity bin restrictions specified by the order code.
  - \* Flux values @ 25 °C are calculated and for reference only.

**FLUX CHARACTERISTICS, EASYWHITE® ORDER CODES AND BINS - 36 V (I<sub>F</sub> = 2400 mA, T<sub>J</sub> = 85 °C) - CONTINUED**

| Nominal CCT | CRI    |     | Minimum Luminous Flux |                   |                    | 2-Step                   |                          | 3-Step                   |                          | 4-Step                   |                          |
|-------------|--------|-----|-----------------------|-------------------|--------------------|--------------------------|--------------------------|--------------------------|--------------------------|--------------------------|--------------------------|
|             | Min    | Typ | Group                 | Flux (lm) @ 85 °C | Flux (lm) @ 25 °C* | Group                    | Order Code               | Group                    | Order Code               | Group                    | Order Code               |
| 3000 K      | 80     | --- | AD                    | 9,000             | 10,157             | 30H                      | CXA3590-0000-000NT0AD30H | 30G                      | CXA3590-0000-000NT0AD30G | 30F                      | CXA3590-0000-000NT0AD30F |
|             |        |     | BB                    | 9,500             | 10,721             |                          | CXA3590-0000-000NT0BB30H |                          | CXA3590-0000-000NT0BB30G |                          | CXA3590-0000-000NT0BB30F |
|             |        |     | BD                    | 10,000            | 11,286             |                          | CXA3590-0000-000NT0BD30H |                          | CXA3590-0000-000NT0BD30G |                          | CXA3590-0000-000NT0BD30F |
|             | 93     | 95  | Z2                    | 7,390             | 8,340              | 30H                      | CXA3590-0000-000NTYZ230H | 30G                      | CXA3590-0000-000NTYZ230G | 30F                      | CXA3590-0000-000NTYZ230F |
|             |        |     | Z4                    | 7,945             | 8,967              |                          | CXA3590-0000-000NTYZ430H |                          | CXA3590-0000-000NTYZ430G |                          | CXA3590-0000-000NTYZ430F |
|             | 2700 K | 80  | ---                   | AB                | 8,500              | 9,593                    | 27H                      | CXA3590-0000-000NT0AB27H | 27G                      | CXA3590-0000-000NT0AB27G | 27F                      |
| AD          |        |     |                       | 9,000             | 10,157             | CXA3590-0000-000NT0AD27H |                          | CXA3590-0000-000NT0AD27G |                          | CXA3590-0000-000NT0AD27F |                          |
| BB          |        |     |                       | 9,500             | 10,721             | CXA3590-0000-000NT0BB27H |                          | CXA3590-0000-000NT0BB27G |                          | CXA3590-0000-000NT0BB27F |                          |
| 93          |        | 95  | Y4                    | 6,910             | 7,798              | 27H                      | CXA3590-0000-000NTYY427H | 27G                      | CXA3590-0000-000NTYY427G | 27F                      | CXA3590-0000-000NTYY427F |
|             |        |     | Z2                    | 7,390             | 8,340              |                          | CXA3590-0000-000NTYZ227H |                          | CXA3590-0000-000NTYZ227G |                          | CXA3590-0000-000NTYZ227F |

- Notes**
- Cree LED maintains a tolerance of ±7% on flux and power measurements, ±0.005 on chromaticity (CCx, CCy) measurements and a tolerance of ±2 on CRI measurements. See the Measurements section (page 24).
  - CXA3590 LED order codes specify only a minimum flux bin and not a maximum. Cree LED may ship reels in flux bins higher than the minimum specified by the order code without advance notice. Shipments will always adhere to the chromaticity bin restrictions specified by the order code.
  - \* Flux values @ 25 °C are calculated and for reference only.

**FLUX CHARACTERISTICS, ANSI WHITE ORDER CODES AND BINS - 36 V (I<sub>F</sub> = 2400 mA, T<sub>J</sub> = 85 °C)**

The following table provides order codes for XLamp CXA3590 LEDs. For a complete description of the order code nomenclature, please see the Bin and Order Code Formats section (page 21).

| CCT Range | CRI |     | Minimum Luminous Flux |                   |                    | Chromaticity Regions    | Order Code               |
|-----------|-----|-----|-----------------------|-------------------|--------------------|-------------------------|--------------------------|
|           | Min | Typ | Group                 | Flux (lm) @ 85 °C | Flux (lm) @ 25 °C* |                         |                          |
| 6500 K    | 70  | 75  | BD                    | 10,000            | 11,286             | 1A0, 1B0, 1C0, 1D0, 65F | CXA3590-0000-000NT0BD0E1 |
|           |     |     | CB                    | 11,000            | 12,414             |                         | CXA3590-0000-000NT0CB0E1 |
|           |     |     | CD                    | 12,000            | 13,543             |                         | CXA3590-0000-000NT0CD0E1 |
|           | 80  | --- | BB                    | 9,500             | 11,286             | 1A0, 1B0, 1C0, 1D0, 65F | CXA3590-0000-000NTHBB0E1 |
|           |     |     | BD                    | 10,000            | 12,414             |                         | CXA3590-0000-000NTHBD0E1 |
|           |     |     | CB                    | 11,000            | 13,543             |                         | CXA3590-0000-000NTHCB0E1 |
| 5700 K    | 70  | 75  | BD                    | 10,000            | 11,286             | 2A0, 2B0, 2C0, 2D0, 57F | CXA3590-0000-000NT0BD0E2 |
|           |     |     | CB                    | 11,000            | 12,414             |                         | CXA3590-0000-000NT0CB0E2 |
|           |     |     | CD                    | 12,000            | 13,543             |                         | CXA3590-0000-000NT0CD0E2 |
|           | 80  | --- | BB                    | 9,500             | 11,286             | 2A0, 2B0, 2C0, 2D0, 57F | CXA3590-0000-000NTHBB0E2 |
|           |     |     | BD                    | 10,000            | 12,414             |                         | CXA3590-0000-000NTHBD0E2 |
|           |     |     | CB                    | 11,000            | 13,543             |                         | CXA3590-0000-000NTHCB0E2 |
| 5000 K    | 70  | 75  | BD                    | 10,000            | 11,286             | 3A0, 3B0, 3C0, 3D0, 50F | CXA3590-0000-000NT0BD0E3 |
|           |     |     | CB                    | 11,000            | 12,414             |                         | CXA3590-0000-000NT0CB0E3 |
|           |     |     | CD                    | 12,000            | 13,543             |                         | CXA3590-0000-000NT0CD0E3 |
|           | 80  | --- | BB                    | 9,500             | 11,286             | 3A0, 3B0, 3C0, 3D0, 50F | CXA3590-0000-000NTHBB0E3 |
|           |     |     | BD                    | 10,000            | 12,414             |                         | CXA3590-0000-000NTHBD0E3 |
|           |     |     | CB                    | 11,000            | 13,543             |                         | CXA3590-0000-000NTHCB0E3 |

- Notes**
- Cree LED maintains a tolerance of ±7% on flux and power measurements, ±0.005 on chromaticity (CC<sub>x</sub>, CC<sub>y</sub>) measurements and a tolerance of ±2 on CRI measurements. See the Measurements section (page 24).
  - CXA3590 LED order codes specify only a minimum flux bin and not a maximum. Cree LED may ship reels in flux bins higher than the minimum specified by the order code without advance notice. Shipments will always adhere to the chromaticity bin restrictions specified by the order code.
  - \* Flux values @ 25 °C are calculated and for reference only.

**FLUX CHARACTERISTICS, EASYWHITE® ORDER CODES AND BINS - 72 V (I<sub>F</sub> = 1200 mA, T<sub>J</sub> = 85 °C)**

The following table provides order codes for XLamp CXA3590 LEDs. For a complete description of the order code nomenclature, please see the Bin and Order Code Formats section (page 21).

| Nominal CCT | CRI |     | Minimum Luminous Flux |                   |                    | 2-Step |            | 3-Step |                          | 4-Step |                          |
|-------------|-----|-----|-----------------------|-------------------|--------------------|--------|------------|--------|--------------------------|--------|--------------------------|
|             | Min | Typ | Group                 | Flux (lm) @ 85 °C | Flux (lm) @ 25 °C* | Group  | Order Code | Group  | Order Code               | Group  | Order Code               |
| 6500 K      | 70  | 75  | BD                    | 10,000            | 11,286             |        |            |        |                          | 65F    | CXA3590-0000-000RT0BD65F |
|             |     |     | CB                    | 11,000            | 12,414             |        |            |        | CXA3590-0000-000RT0CB65F |        |                          |
|             |     |     | CD                    | 12,000            | 13,543             |        |            |        | CXA3590-0000-000RT0CD65F |        |                          |
|             | 80  | --- | BB                    | 9,500             | 10,721             |        |            |        |                          | 65F    | CXA3590-0000-000RTHBB65F |
|             |     |     | BD                    | 10,000            | 11,286             |        |            |        | CXA3590-0000-000RTHBD65F |        |                          |
|             |     |     | CB                    | 11,000            | 12,414             |        |            |        | CXA3590-0000-000RTHCB65F |        |                          |
|             | 90  | 95  | Z4                    | 7,945             | 8,967              |        |            |        |                          | 65F    | CXA3590-0000-000RTUZ465F |
|             |     |     | AB                    | 8,500             | 9,593              |        |            |        | CXA3590-0000-000RTUAB65F |        |                          |
|             |     |     | AD                    | 9,000             | 10,157             |        |            |        | CXA3590-0000-000RTUAD65F |        |                          |
| 5700 K      | 70  | 75  | BD                    | 10,000            | 11,286             |        |            |        |                          | 57F    | CXA3590-0000-000RT0BD57F |
|             |     |     | CB                    | 11,000            | 12,414             |        |            |        | CXA3590-0000-000RT0CB57F |        |                          |
|             |     |     | CD                    | 12,000            | 13,543             |        |            |        | CXA3590-0000-000RT0CD57F |        |                          |
|             | 80  | --- | BB                    | 9,500             | 10,721             |        |            |        |                          | 57F    | CXA3590-0000-000RTHBB57F |
|             |     |     | BD                    | 10,000            | 11,286             |        |            |        | CXA3590-0000-000RTHBD57F |        |                          |
|             |     |     | CB                    | 11,000            | 12,414             |        |            |        | CXA3590-0000-000RTHCB57F |        |                          |

- Notes
- Cree LED maintains a tolerance of ±7% on flux and power measurements, ±0.005 on chromaticity (CCx, CCy) measurements and a tolerance of ±2 on CRI measurements. See the Measurements section (page 24).
  - CXA3590 LED order codes specify only a minimum flux bin and not a maximum. Cree LED may ship reels in flux bins higher than the minimum specified by the order code without advance notice. Shipments will always adhere to the chromaticity bin restrictions specified by the order code.
  - \* Flux values @ 25 °C are calculated and for reference only.

**FLUX CHARACTERISTICS, EASYWHITE® ORDER CODES AND BINS - 72 V (I<sub>F</sub> = 1200 mA, T<sub>J</sub> = 85 °C) - CONTINUED**

| Nominal CCT | CRI    |     | Minimum Luminous Flux |                   |                    | 2-Step                   |                          | 3-Step                   |                          | 4-Step                   |                          |
|-------------|--------|-----|-----------------------|-------------------|--------------------|--------------------------|--------------------------|--------------------------|--------------------------|--------------------------|--------------------------|
|             | Min    | Typ | Group                 | Flux (lm) @ 85 °C | Flux (lm) @ 25 °C* | Group                    | Order Code               | Group                    | Order Code               | Group                    | Order Code               |
| 5000 K      | 70     | 75  | BD                    | 10,000            | 11,286             | 50H                      | CXA3590-0000-000RT0BD50H | 50F                      | CXA3590-0000-000RT0BD50F |                          |                          |
|             |        |     | CB                    | 11,000            | 12,414             |                          | CXA3590-0000-000RT0CB50H |                          | CXA3590-0000-000RT0CB50F |                          |                          |
|             |        |     | CD                    | 12,000            | 13,543             |                          | CXA3590-0000-000RT0CD50H |                          | CXA3590-0000-000RT0CD50F |                          |                          |
|             | 80     | --- | BB                    | 9,500             | 10,721             | 50H                      | CXA3590-0000-000RTHBB50H | 50G                      | CXA3590-0000-000RTHBB50G | 50F                      | CXA3590-0000-000RTHBB50F |
|             |        |     | BD                    | 10,000            | 11,286             |                          | CXA3590-0000-000RTHBD50H |                          | CXA3590-0000-000RTHBD50G |                          | CXA3590-0000-000RTHBD50F |
|             |        |     | CB                    | 11,000            | 12,414             |                          | CXA3590-0000-000RTHCB50H |                          | CXA3590-0000-000RTHCB50G |                          | CXA3590-0000-000RTHCB50F |
|             | 90     | 95  | AB                    | 8,500             | 9,593              | 50H                      | CXA3590-0000-000RTUAB50H | 50G                      | CXA3590-0000-000RTUAB50G | 50F                      | CXA3590-0000-000RTUAB50F |
|             |        |     | AD                    | 9,000             | 10,157             |                          | CXA3590-0000-000RTUAD50H |                          | CXA3590-0000-000RTUAD50G |                          | CXA3590-0000-000RTUAD50F |
|             | 4000 K | 70  | 75                    | BB                | 9,500              | 10,721                   | 40H                      | CXA3590-0000-000RT0BB40H | 40F                      | CXA3590-0000-000RT0BB40F |                          |
| BD          |        |     |                       | 10,000            | 11,286             | CXA3590-0000-000RT0BD40H |                          | CXA3590-0000-000RT0BD40F |                          |                          |                          |
| CB          |        |     |                       | 11,000            | 12,414             | CXA3590-0000-000RT0CB40H |                          | CXA3590-0000-000RT0CB40F |                          |                          |                          |
| 80          |        | --- | AD                    | 9,000             | 10,157             | 40H                      | CXA3590-0000-000RTHAD40H | 40G                      | CXA3590-0000-000RTHAD40G | 40F                      | CXA3590-0000-000RTHAD40F |
|             |        |     | BB                    | 9,500             | 10,721             |                          | CXA3590-0000-000RTHBB40H |                          | CXA3590-0000-000RTHBB40G |                          | CXA3590-0000-000RTHBB40F |
|             |        |     | BD                    | 10,000            | 11,286             |                          | CXA3590-0000-000RTHBD40H |                          | CXA3590-0000-000RTHBD40G |                          | CXA3590-0000-000RTHBD40F |
| 90          | 95     | Z4  | 7,945                 | 8,967             | 40H                | CXA3590-0000-000RTUZ440H | 40G                      | CXA3590-0000-000RTUZ440G | 40F                      | CXA3590-0000-000RTUZ440F |                          |
|             |        | AB  | 8,500                 | 9,593             |                    | CXA3590-0000-000RTUAB40H |                          | CXA3590-0000-000RTUAB40G |                          | CXA3590-0000-000RTUAB40F |                          |
| 3500 K      | 80     | --- | AD                    | 9,000             | 10,157             | 35H                      | CXA3590-0000-000RT0AD35H | 35G                      | CXA3590-0000-000RT0AD35G | 35F                      | CXA3590-0000-000RT0AD35F |
|             |        |     | BB                    | 9,500             | 10,721             |                          | CXA3590-0000-000RT0BB35H |                          | CXA3590-0000-000RT0BB35G |                          | CXA3590-0000-000RT0BB35F |
|             |        |     | BD                    | 10,000            | 11,286             |                          | CXA3590-0000-000RT0BD35H |                          | CXA3590-0000-000RT0BD35G |                          | CXA3590-0000-000RT0BD35F |
|             | 93     | 95  | Z2                    | 7,390             | 8,340              | 35H                      | CXA3590-0000-000RTYZ235H | 35G                      | CXA3590-0000-000RTYZ235G | 35F                      | CXA3590-0000-000RTYZ235F |
|             |        |     | Z4                    | 7,945             | 8,967              |                          | CXA3590-0000-000RTYZ435H |                          | CXA3590-0000-000RTYZ435G |                          | CXA3590-0000-000RTYZ435F |

- Notes**
- Cree LED maintains a tolerance of ±7% on flux and power measurements, ±0.005 on chromaticity (CCx, CCy) measurements and a tolerance of ±2 on CRI measurements. See the Measurements section (page 24).
  - CXA3590 LED order codes specify only a minimum flux bin and not a maximum. Cree LED may ship reels in flux bins higher than the minimum specified by the order code without advance notice. Shipments will always adhere to the chromaticity bin restrictions specified by the order code.
  - \* Flux values @ 25 °C are calculated and for reference only.

**FLUX CHARACTERISTICS, EASYWHITE® ORDER CODES AND BINS - 72 V (I<sub>F</sub> = 1200 mA, T<sub>J</sub> = 85 °C) - CONTINUED**

| Nominal CCT | CRI    |     | Minimum Luminous Flux |                   |                    | 2-Step                   |                          | 3-Step                   |                          | 4-Step                   |                          |
|-------------|--------|-----|-----------------------|-------------------|--------------------|--------------------------|--------------------------|--------------------------|--------------------------|--------------------------|--------------------------|
|             | Min    | Typ | Group                 | Flux (lm) @ 85 °C | Flux (lm) @ 25 °C* | Group                    | Order Code               | Group                    | Order Code               | Group                    | Order Code               |
| 3000 K      | 80     | --- | AD                    | 9,000             | 10,157             | 30H                      | CXA3590-0000-000RT0AD30H | 30G                      | CXA3590-0000-000RT0AD30G | 30F                      | CXA3590-0000-000RT0AD30F |
|             |        |     | BB                    | 9,500             | 10,721             |                          | CXA3590-0000-000RT0BB30H |                          | CXA3590-0000-000RT0BB30G |                          | CXA3590-0000-000RT0BB30F |
|             |        |     | BD                    | 10,000            | 11,286             |                          | CXA3590-0000-000RT0BD30H |                          | CXA3590-0000-000RT0BD30G |                          | CXA3590-0000-000RT0BD30F |
|             | 93     | 95  | Z2                    | 7,390             | 8,340              | 30H                      | CXA3590-0000-000RTYZ230H | 30G                      | CXA3590-0000-000RTYZ230G | 30F                      | CXA3590-0000-000RTYZ230F |
|             |        |     | Z4                    | 7,945             | 8,967              |                          | CXA3590-0000-000RTYZ430H |                          | CXA3590-0000-000RTYZ430G |                          | CXA3590-0000-000RTYZ430F |
|             | 2700 K | 80  | ---                   | AB                | 8,500              | 9,593                    | 27H                      | CXA3590-0000-000RT0AB27H | 27G                      | CXA3590-0000-000RT0AB27G | 27F                      |
| AD          |        |     |                       | 9,000             | 10,157             | CXA3590-0000-000RT0AD27H |                          | CXA3590-0000-000RT0AD27G |                          | CXA3590-0000-000RT0AD27F |                          |
| BB          |        |     |                       | 9,500             | 10,721             | CXA3590-0000-000RT0BB27H |                          | CXA3590-0000-000RT0BB27G |                          | CXA3590-0000-000RT0BB27F |                          |
| 93          |        | 95  | Y4                    | 6,910             | 7,798              | 27H                      | CXA3590-0000-000RTYY427H | 27G                      | CXA3590-0000-000RTYY427G | 27F                      | CXA3590-0000-000RTYY427F |
|             |        |     | Z2                    | 7,390             | 8,340              |                          | CXA3590-0000-000RTYZ227H |                          | CXA3590-0000-000RTYZ227G |                          | CXA3590-0000-000RTYZ227F |

- Notes**
- Cree LED maintains a tolerance of ±7% on flux and power measurements, ±0.005 on chromaticity (CCx, CCy) measurements and a tolerance of ±2 on CRI measurements. See the Measurements section (page 24).
  - CXA3590 LED order codes specify only a minimum flux bin and not a maximum. Cree LED may ship reels in flux bins higher than the minimum specified by the order code without advance notice. Shipments will always adhere to the chromaticity bin restrictions specified by the order code.
  - \* Flux values @ 25 °C are calculated and for reference only.

**FLUX CHARACTERISTICS, ANSI WHITE ORDER CODES AND BINS - 72 V (I<sub>F</sub> = 1200 mA, T<sub>J</sub> = 85 °C)**

The following table provides order codes for XLamp CXA3590 LEDs. For a complete description of the order code nomenclature, please see the Bin and Order Code Formats section (page 21).

| CCT Range | CRI |     | Minimum Luminous Flux |                   |                    | Chromaticity Regions    | Order Code               |
|-----------|-----|-----|-----------------------|-------------------|--------------------|-------------------------|--------------------------|
|           | Min | Typ | Group                 | Flux (lm) @ 85 °C | Flux (lm) @ 25 °C* |                         |                          |
| 6500 K    | 70  | 75  | BD                    | 10,000            | 11,286             | 1A0, 1B0, 1C0, 1D0, 65F | CXA3590-0000-000RT0BD0E1 |
|           |     |     | CB                    | 11,000            | 12,414             |                         | CXA3590-0000-000RT0CB0E1 |
|           |     |     | CD                    | 12,000            | 13,543             |                         | CXA3590-0000-000RT0CD0E1 |
|           | 80  | --- | BB                    | 9,500             | 11,286             | 1A0, 1B0, 1C0, 1D0, 65F | CXA3590-0000-000RTHBB0E1 |
|           |     |     | BD                    | 10,000            | 12,414             |                         | CXA3590-0000-000RTHBD0E1 |
|           |     |     | CB                    | 11,000            | 13,543             |                         | CXA3590-0000-000RTHCB0E1 |
| 5700 K    | 70  | 75  | BD                    | 10,000            | 11,286             | 2A0, 2B0, 2C0, 2D0, 57F | CXA3590-0000-000RT0BD0E2 |
|           |     |     | CB                    | 11,000            | 12,414             |                         | CXA3590-0000-000RT0CB0E2 |
|           |     |     | CD                    | 12,000            | 13,543             |                         | CXA3590-0000-000RT0CD0E2 |
|           | 80  | --- | BB                    | 9,500             | 11,286             | 2A0, 2B0, 2C0, 2D0, 57F | CXA3590-0000-000RTHBB0E2 |
|           |     |     | BD                    | 10,000            | 12,414             |                         | CXA3590-0000-000RTHBD0E2 |
|           |     |     | CB                    | 11,000            | 13,543             |                         | CXA3590-0000-000RTHCB0E2 |
| 5000 K    | 70  | 75  | BD                    | 10,000            | 11,286             | 3A0, 3B0, 3C0, 3D0, 50F | CXA3590-0000-000RT0BD0E3 |
|           |     |     | CB                    | 11,000            | 12,414             |                         | CXA3590-0000-000RT0CB0E3 |
|           |     |     | CD                    | 12,000            | 13,543             |                         | CXA3590-0000-000RT0CD0E3 |
|           | 80  | --- | BB                    | 9,500             | 11,286             | 3A0, 3B0, 3C0, 3D0, 50F | CXA3590-0000-000RTHBB0E3 |
|           |     |     | BD                    | 10,000            | 12,414             |                         | CXA3590-0000-000RTHBD0E3 |
|           |     |     | CB                    | 11,000            | 13,543             |                         | CXA3590-0000-000RTHCB0E3 |

- Notes**
- Cree LED maintains a tolerance of ±7% on flux and power measurements, ±0.005 on chromaticity (CCx, CCy) measurements and a tolerance of ±2 on CRI measurements. See the Measurements section (page 24).
  - CXA3590 LED order codes specify only a minimum flux bin and not a maximum. Cree LED may ship reels in flux bins higher than the minimum specified by the order code without advance notice. Shipments will always adhere to the chromaticity bin restrictions specified by the order code.
  - \* Flux values @ 25 °C are calculated and for reference only.

## RELATIVE SPECTRAL POWER DISTRIBUTION

The following graph is the result of a series of pulsed measurements at 2400 mA for the 36-V CXA3590 and 1200 mA for the 72-V CXA3590 and  $T_j = 85\text{ }^\circ\text{C}$ .

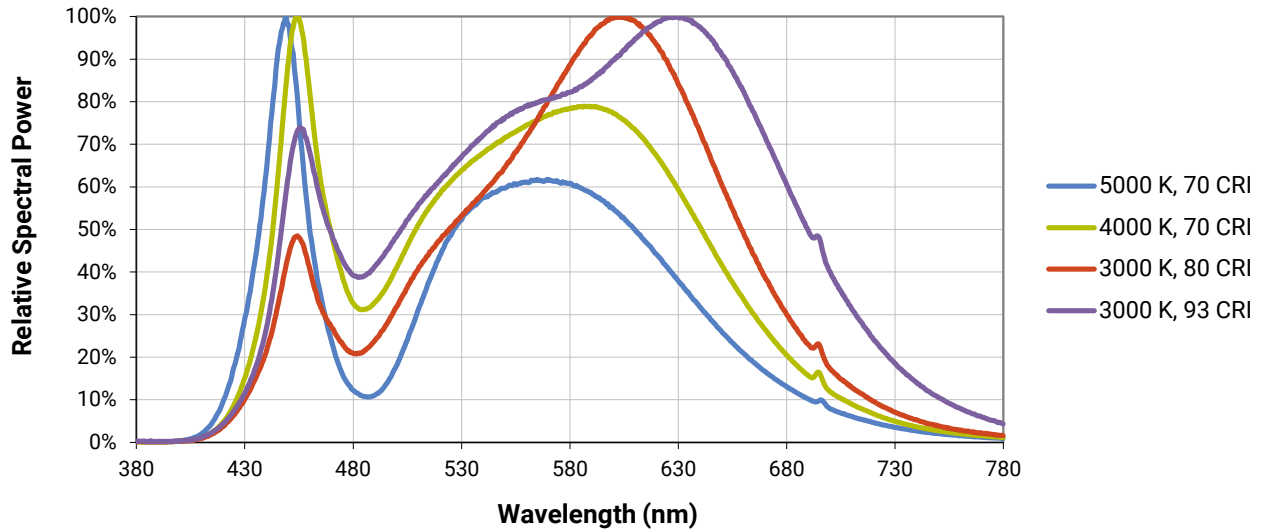

## ELECTRICAL CHARACTERISTICS

The following graphs are the result of a series of steady-state measurements.

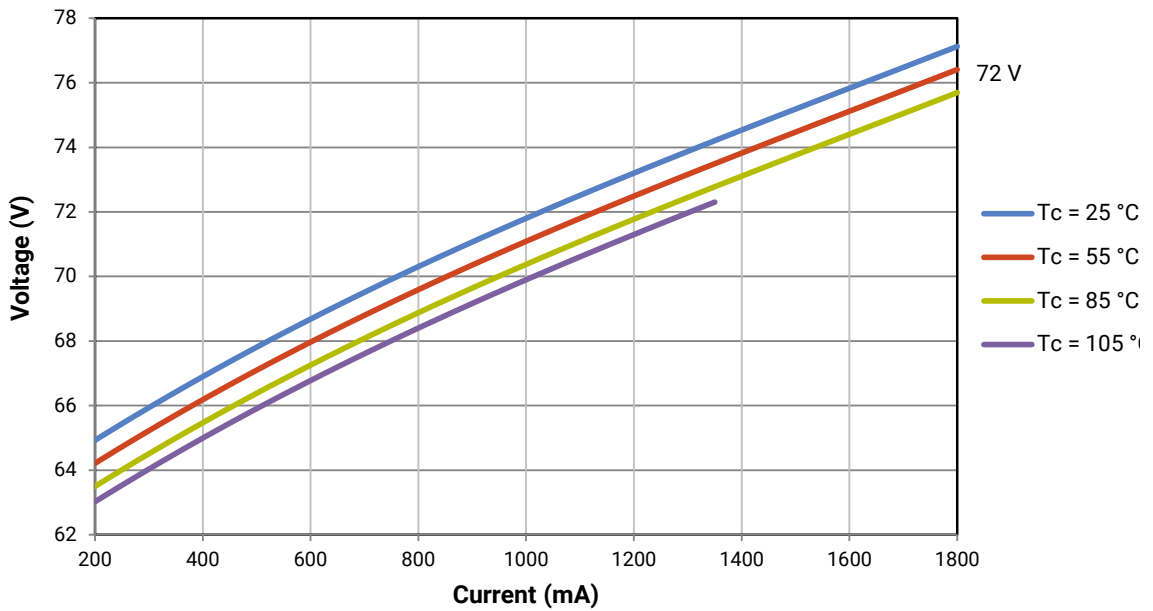
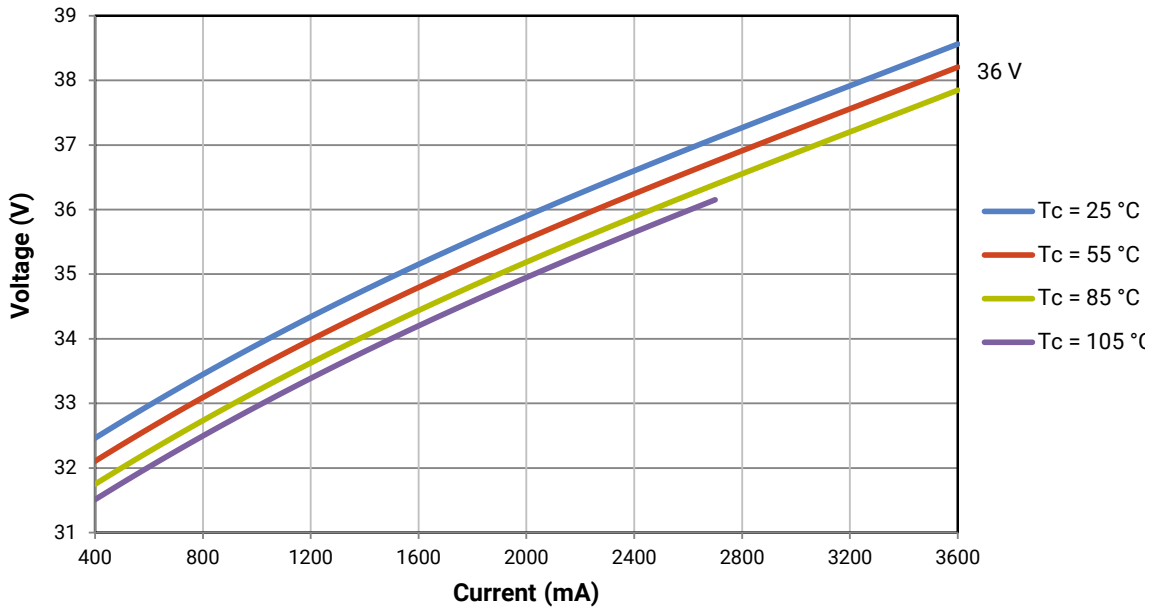

## RELATIVE LUMINOUS FLUX

The relative luminous flux values provided below are the ratio of:

- Measurements of CXA3590 at steady-state operation at the given conditions, divided by
- Flux measured during binning, which is a pulsed measurement at 2400 mA at  $T_j = 85\text{ °C}$  for the 36-V CXA3590.

Using the 36-V CXA3590 LED as an example, at steady-state operation of  $T_c = 25\text{ °C}$ ,  $I_f = 1200\text{ mA}$ , the relative luminous flux ratio is 60% in the chart below. A CXA3590 LED that measures 11,000 lm during binning will deliver 6,600 lm ( $11,000 \times 0.6$ ) at steady-state operation of  $T_c = 25\text{ °C}$ ,  $I_f = 1200\text{ mA}$ .

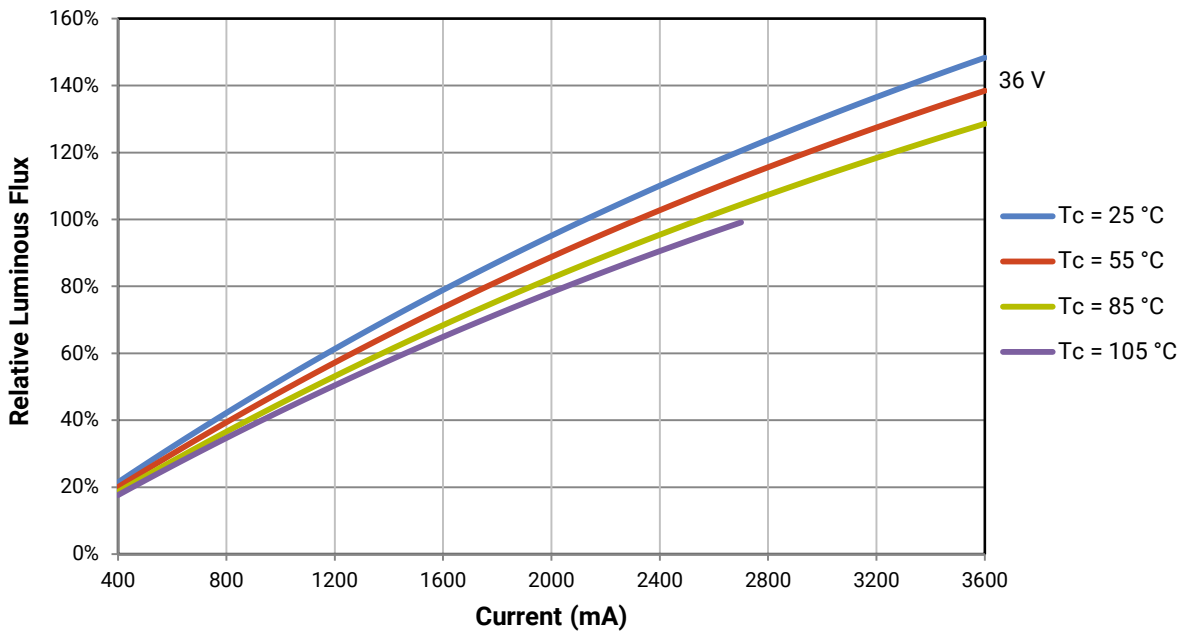

## RELATIVE LUMINOUS FLUX - CONTINUED

The relative luminous flux values provided below are the ratio of:

- Measurements of CXA3590 at steady-state operation at the given conditions, divided by
- Flux measured during binning, which is a pulsed measurement at 1200 mA at  $T_j = 85^\circ\text{C}$  for the 72-V CXA3590.

Using the 72-V CXA3590 LED as an example, at steady-state operation of  $T_c = 25^\circ\text{C}$ ,  $I_f = 800\text{ mA}$ , the relative luminous flux ratio is 80% in the chart below. A CXA3590 LED that measures 11,000 lm during binning will deliver 8,800 lm ( $11,000 \times 0.8$ ) at steady-state operation of  $T_c = 25^\circ\text{C}$ ,  $I_f = 800\text{ mA}$ .

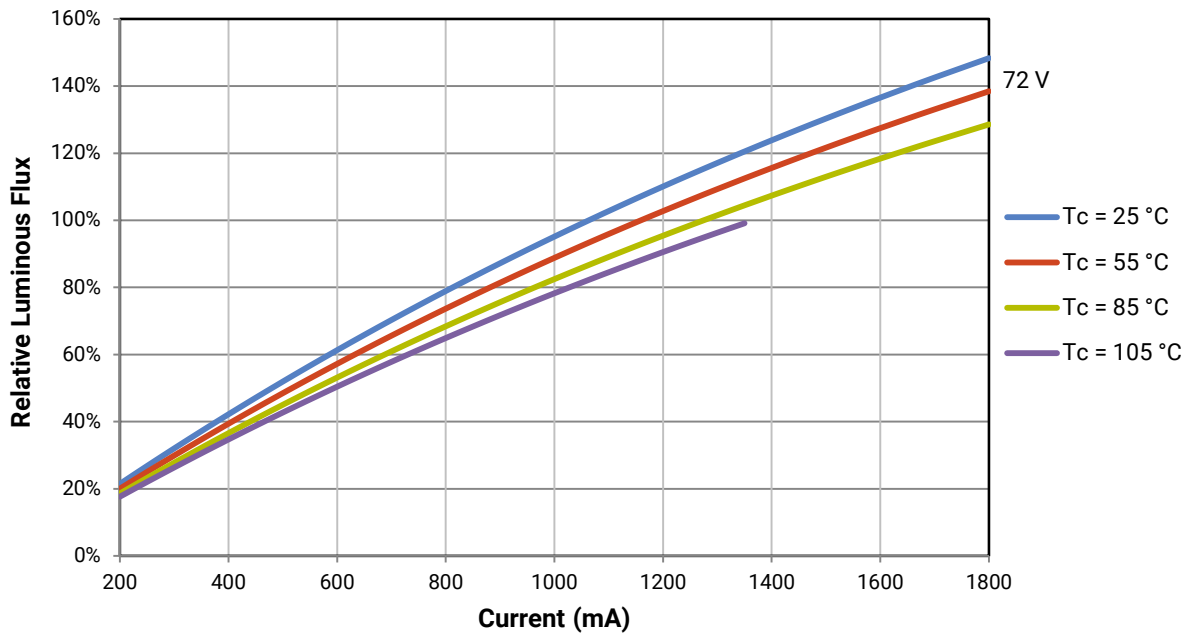

## TYPICAL SPATIAL DISTRIBUTION

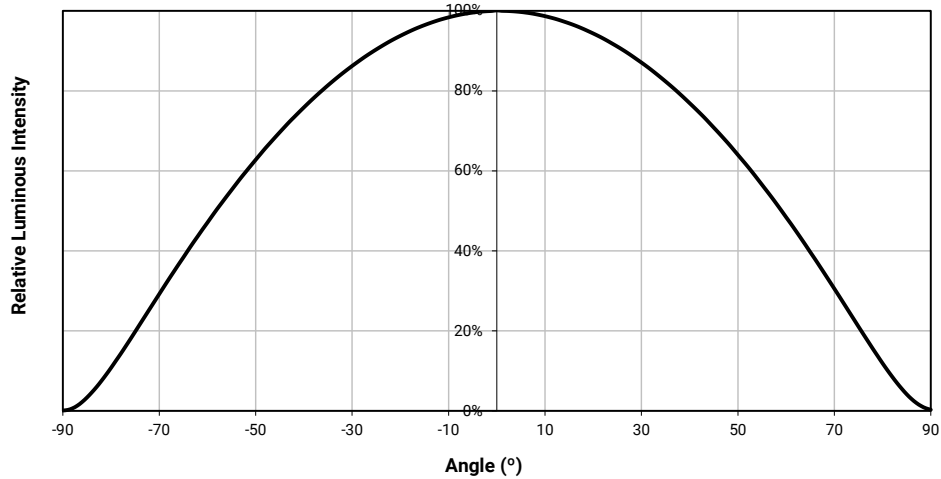

## PERFORMANCE GROUPS - BRIGHTNESS (36 V, I<sub>F</sub> = 2400 mA; 72 V I<sub>F</sub> = 1200 mA, T<sub>J</sub> = 85 °C)

XLamp CXA3590 LEDs are tested for luminous flux and placed into one of the following bins.

| Group Code | Minimum Luminous Flux | Maximum Luminous Flux |
|------------|-----------------------|-----------------------|
| Y4         | 6,910                 | 7,390                 |
| Z2         | 7,390                 | 7,945                 |
| Z4         | 7,945                 | 8,500                 |
| AB         | 8,500                 | 9,000                 |
| AD         | 9,000                 | 9,500                 |
| BB         | 9,500                 | 10,000                |
| BD         | 10,000                | 11,000                |
| CB         | 11,000                | 12,000                |
| CD         | 12,000                | 13,000                |
| DB         | 13,000                | 14,000                |

## PERFORMANCE GROUPS - CHROMATICITY ( $T_j = 85\text{ }^\circ\text{C}$ )

XLamp CXA3590 LEDs are tested for chromaticity and placed into one of the regions defined by the following bounding coordinates.

| EasyWhite Color Temperatures – 2-Step |        |        |        |
|---------------------------------------|--------|--------|--------|
| Code                                  | CCT    | x      | y      |
| 50H                                   | 5000 K | 0.3429 | 0.3507 |
|                                       |        | 0.3434 | 0.3571 |
|                                       |        | 0.3475 | 0.3604 |
|                                       |        | 0.3469 | 0.3539 |
| 40H                                   | 4000 K | 0.3784 | 0.3741 |
|                                       |        | 0.3804 | 0.3818 |
|                                       |        | 0.3867 | 0.3857 |
|                                       |        | 0.3844 | 0.3778 |
| 35H                                   | 3500 K | 0.4030 | 0.3857 |
|                                       |        | 0.4061 | 0.3941 |
|                                       |        | 0.4132 | 0.3976 |
|                                       |        | 0.4099 | 0.3890 |
| 30H                                   | 3000 K | 0.4291 | 0.3973 |
|                                       |        | 0.4333 | 0.4062 |
|                                       |        | 0.4395 | 0.4084 |
|                                       |        | 0.4351 | 0.3994 |
| 27H                                   | 2700 K | 0.4528 | 0.4046 |
|                                       |        | 0.4578 | 0.4138 |
|                                       |        | 0.4638 | 0.4152 |
|                                       |        | 0.4586 | 0.4060 |

| EasyWhite Color Temperatures – 3-Step Ellipse |        |              |        |            |            |                    |
|---|--------|--------------|--------|------------|------------|--------------------|
| Bin Code                                      | CCT    | Center Point |        | Major Axis | Minor Axis | Rotation Angle (°) |
|   |        | x            | y      | a          | b          |                    |
| 50G   | 5000 K | 0.3447       | 0.3553 | 0.00840    | 0.00312    | 65.0               |
| 40G   | 4000 K | 0.3818       | 0.3797 | 0.00939    | 0.00402    | 53.7               |
| 35G   | 3500 K | 0.4073       | 0.3917 | 0.00927    | 0.00414    | 54.0               |
| 30G   | 3000 K | 0.4338       | 0.4030 | 0.00834    | 0.00408    | 53.2               |
| 27G   | 2700 K | 0.4577       | 0.4099 | 0.00834    | 0.00420    | 48.5               |

PERFORMANCE GROUPS - CHROMATICITY ( $T_j = 85\text{ }^\circ\text{C}$ ) - CONTINUED

| EasyWhite Color Temperatures – 4-Step |        |        |        |
|---------------------------------------|--------|--------|--------|
| Code                                  | CCT    | x      | y      |
| 65F                                   | 6500 K | 0.3097 | 0.3196 |
|                                       |        | 0.3079 | 0.3297 |
|                                       |        | 0.3164 | 0.3382 |
|                                       |        | 0.3176 | 0.3275 |
| 57F                                   | 5700 K | 0.3253 | 0.3325 |
|                                       |        | 0.3249 | 0.3439 |
|                                       |        | 0.3331 | 0.3514 |
|                                       |        | 0.3330 | 0.3393 |
| 50F                                   | 5000 K | 0.3407 | 0.3459 |
|                                       |        | 0.3415 | 0.3586 |
|                                       |        | 0.3499 | 0.3654 |
|                                       |        | 0.3484 | 0.3521 |
| 40F                                   | 4000 K | 0.3744 | 0.3685 |
|                                       |        | 0.3782 | 0.3837 |
|                                       |        | 0.3912 | 0.3917 |
|                                       |        | 0.3863 | 0.3758 |
| 35F                                   | 3500 K | 0.3981 | 0.3800 |
|                                       |        | 0.4040 | 0.3966 |
|                                       |        | 0.4186 | 0.4037 |
|                                       |        | 0.4116 | 0.3865 |
| 30F                                   | 3000 K | 0.4242 | 0.3919 |
|                                       |        | 0.4322 | 0.4096 |
|                                       |        | 0.4449 | 0.4141 |
|                                       |        | 0.4359 | 0.3960 |
| 27F                                   | 2700 K | 0.4475 | 0.3994 |
|                                       |        | 0.4573 | 0.4178 |
|                                       |        | 0.4695 | 0.4207 |
|                                       |        | 0.4589 | 0.4021 |

PERFORMANCE GROUPS - CHROMATICITY ( $T_j = 85\text{ }^\circ\text{C}$ ) - CONTINUED

| ANSI White Bins |        |          |        |        |
|-----------------|--------|----------|--------|--------|
| Code            | CCT    | Bin Code | x      | y      |
| 0E1             | 6500 K | 1A0      | 0.3048 | 0.3207 |
|                 |        |          | 0.3130 | 0.3290 |
|                 |        |          | 0.3144 | 0.3186 |
|                 |        |          | 0.3068 | 0.3113 |
|                 |        | 1B0      | 0.3028 | 0.3304 |
|                 |        |          | 0.3115 | 0.3391 |
|                 |        |          | 0.3130 | 0.3290 |
|                 |        |          | 0.3048 | 0.3207 |
|                 |        | 1C0      | 0.3115 | 0.3391 |
|                 |        |          | 0.3205 | 0.3481 |
|                 |        |          | 0.3213 | 0.3373 |
|                 |        |          | 0.3130 | 0.3290 |
|                 |        | 1D0      | 0.3130 | 0.3290 |
|                 |        |          | 0.3213 | 0.3373 |
|                 |        |          | 0.3221 | 0.3261 |
|                 |        |          | 0.3144 | 0.3186 |

| ANSI White Bins |        |          |        |        |
|-----------------|--------|----------|--------|--------|
| Code            | CCT    | Bin Code | x      | y      |
| 0E2             | 5700 K | 2A0      | 0.3215 | 0.3350 |
|                 |        |          | 0.3290 | 0.3417 |
|                 |        |          | 0.3290 | 0.3300 |
|                 |        |          | 0.3222 | 0.3243 |
|                 |        | 2B0      | 0.3207 | 0.3462 |
|                 |        |          | 0.3290 | 0.3538 |
|                 |        |          | 0.3290 | 0.3417 |
|                 |        |          | 0.3215 | 0.3350 |
|                 |        | 2C0      | 0.3290 | 0.3538 |
|                 |        |          | 0.3376 | 0.3616 |
|                 |        |          | 0.3371 | 0.3490 |
|                 |        |          | 0.3290 | 0.3417 |
|                 |        | 2D0      | 0.3290 | 0.3417 |
|                 |        |          | 0.3371 | 0.3490 |
|                 |        |          | 0.3366 | 0.3369 |
|                 |        |          | 0.3290 | 0.3300 |

| ANSI White Bins |        |          |       |       |
|-----------------|--------|----------|-------|-------|
| Code            | CCT    | Bin Code | x     | y     |
| 0E3             | 5000 K | 3A0      | .3371 | .3490 |
|                 |        |          | .3451 | .3554 |
|                 |        |          | .3440 | .3427 |
|                 |        |          | .3366 | .3369 |
|                 |        | 3B0      | .3376 | .3616 |
|                 |        |          | .3463 | .3687 |
|                 |        |          | .3451 | .3554 |
|                 |        |          | .3371 | .3490 |
|                 |        | 3C0      | .3463 | .3687 |
|                 |        |          | .3551 | .3760 |
|                 |        |          | .3533 | .3620 |
|                 |        |          | .3451 | .3554 |
|                 |        | 3D0      | .3451 | .3554 |
|                 |        |          | .3533 | .3620 |
|                 |        |          | .3515 | .3487 |
|                 |        |          | .3440 | .3427 |

EASYWHITE® BINS PLOTTED ON THE 1931 CIE COLOR SPACE ( $T_j = 85^\circ\text{C}$ )

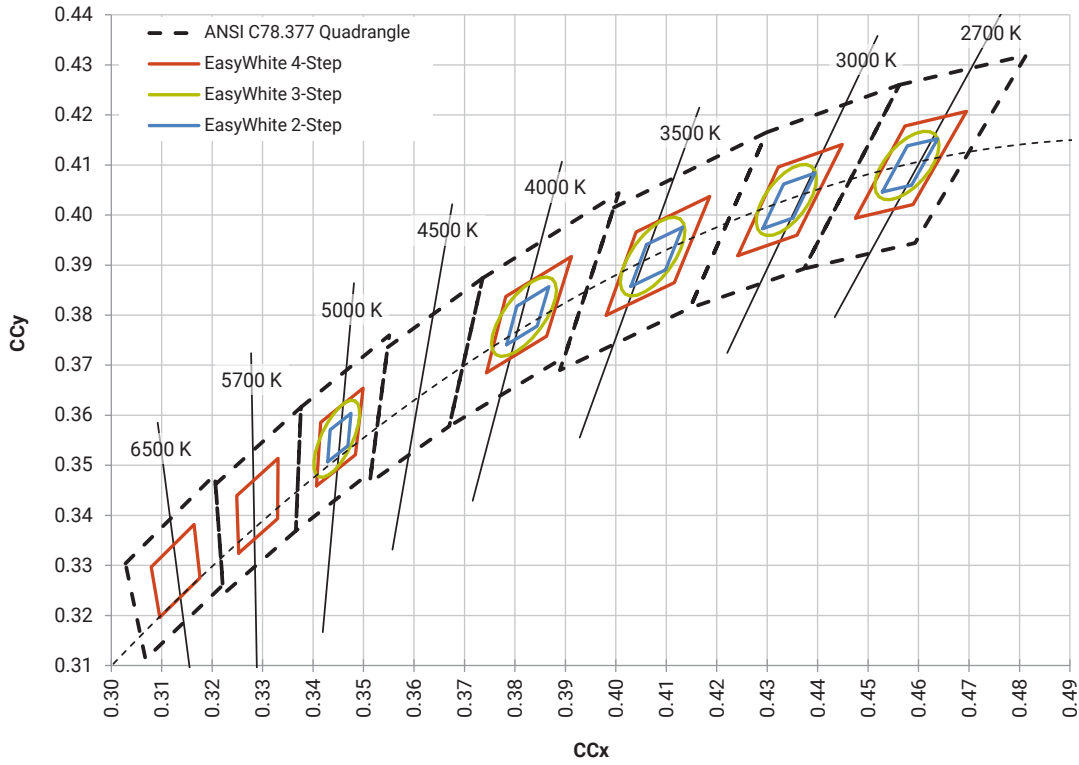

ANSI WHITE BINS PLOTTED ON THE 1931 CIE COLOR SPACE ( $T_j = 85^\circ\text{C}$ )

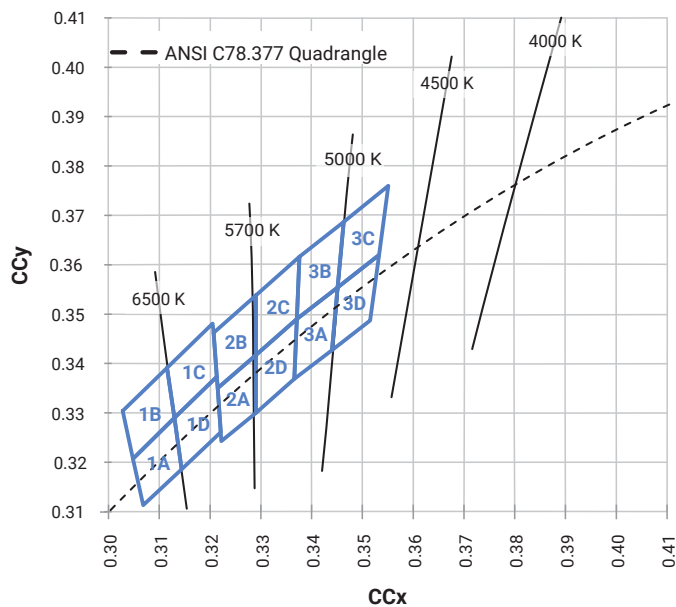

## BIN AND ORDER CODE FORMATS

Bin codes and order codes are configured as follows:

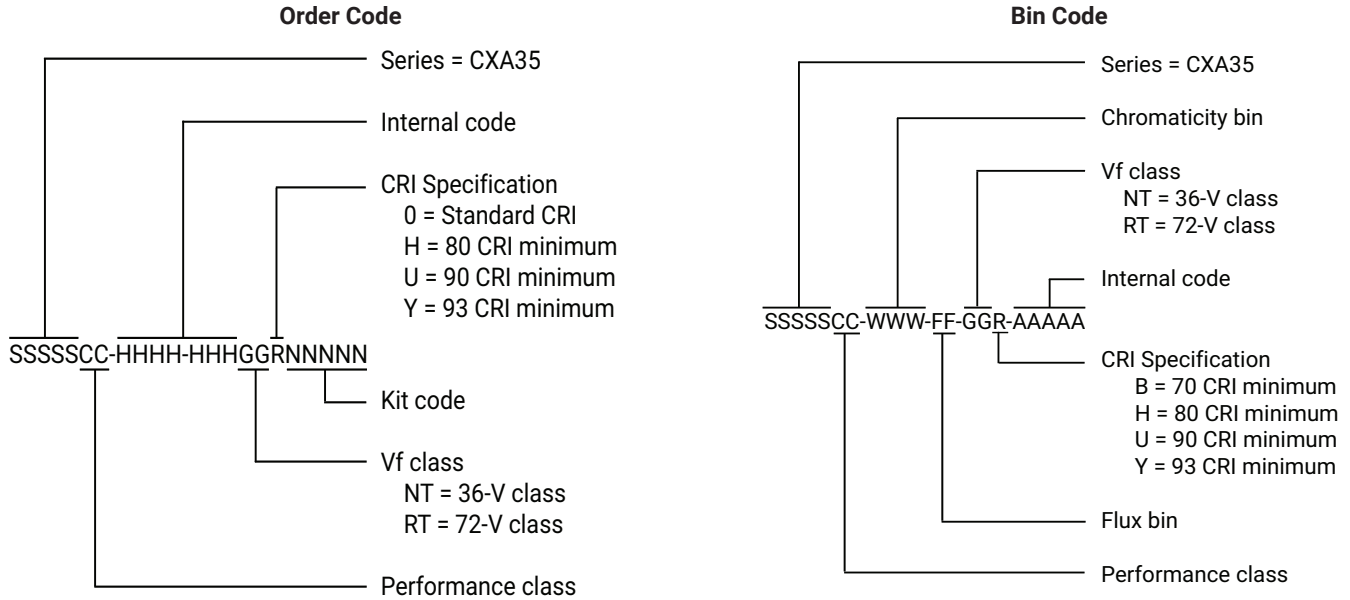

## MECHANICAL DIMENSIONS

Dimensions are in mm.  
 Tolerances unless otherwise specified:  $\pm .13$   
 $x^\circ \pm 1^\circ$

### Meaning of 3590X

3590N = 36-V CXA3590  
 3590R = 72-V CXA3590

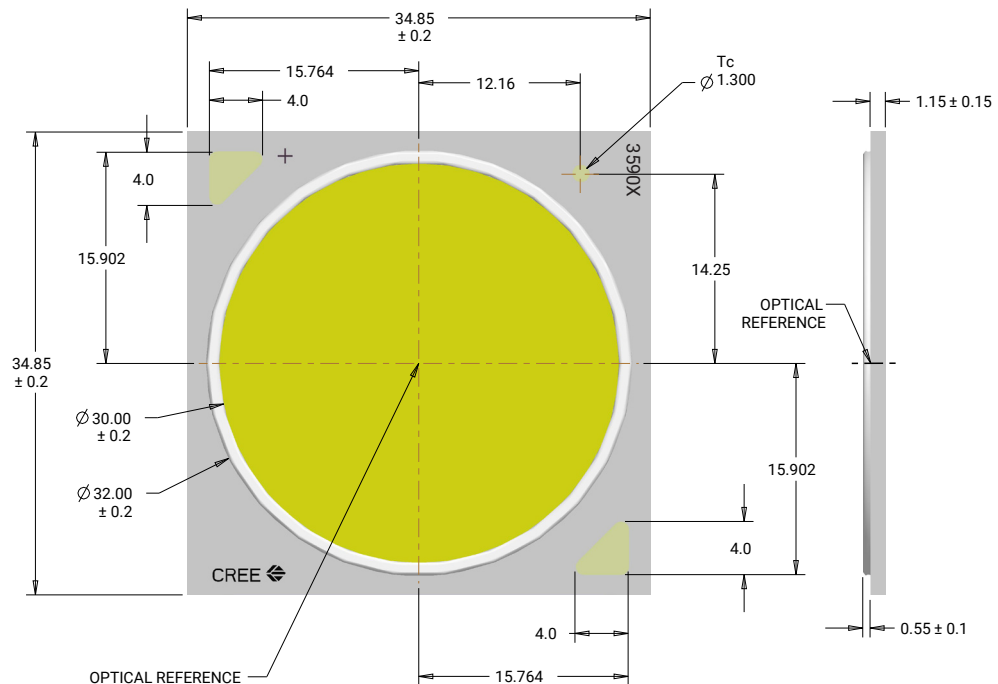

## THERMAL DESIGN

The CXA family of LED arrays can include over a hundred different LED die inside one package, and thus over a hundred different junction temperatures ( $T_j$ ). Cree LED has intentionally removed junction-temperature-based operating limits and replaced the commonplace maximum  $T_j$  calculations with maximum ratings based on forward current ( $I_f$ ) and case temperature ( $T_c$ ). No additional calculations are required to ensure that the CXA LED is being operated within its designed limits. LES temperature measurement provides additional verification of good thermal design. Please refer to page 22 for the Operating Limit specifications.

There is no need to calculate for  $T_j$  inside the package, as the thermal management design process, specifically from  $T_{sp}$  to ambient ( $T_a$ ), remains identical to any other LED component. For more information on thermal management of XLamp LEDs, please refer to the [Thermal Management application note](#). For CXA soldering recommendations and more information on thermal interface materials (TIM), LES temperature measurement, and connection methods, please refer to the [XLamp CX Family LEDs soldering and handling document](#). The [CX Family LED Design Guide](#) provides basic information on the requirements to use XLamp CXA LEDs successfully in luminaire designs.

To keep the CXA3590 LED at or below the maximum rated  $T_c$ , the case to ambient temperature thermal resistance ( $R_{c-a}$ ) must be at or below the maximum  $R_{c-a}$  value shown on the following graph, depending on the operating environment. The y-axis in each graph is a base 10 logarithmic scale.

As the figure at right shows, the  $R_{c-a}$  value is the sum of the thermal resistance of the TIM ( $R_{tim}$ ) plus the thermal resistance of the heat sink ( $R_{hs}$ ).

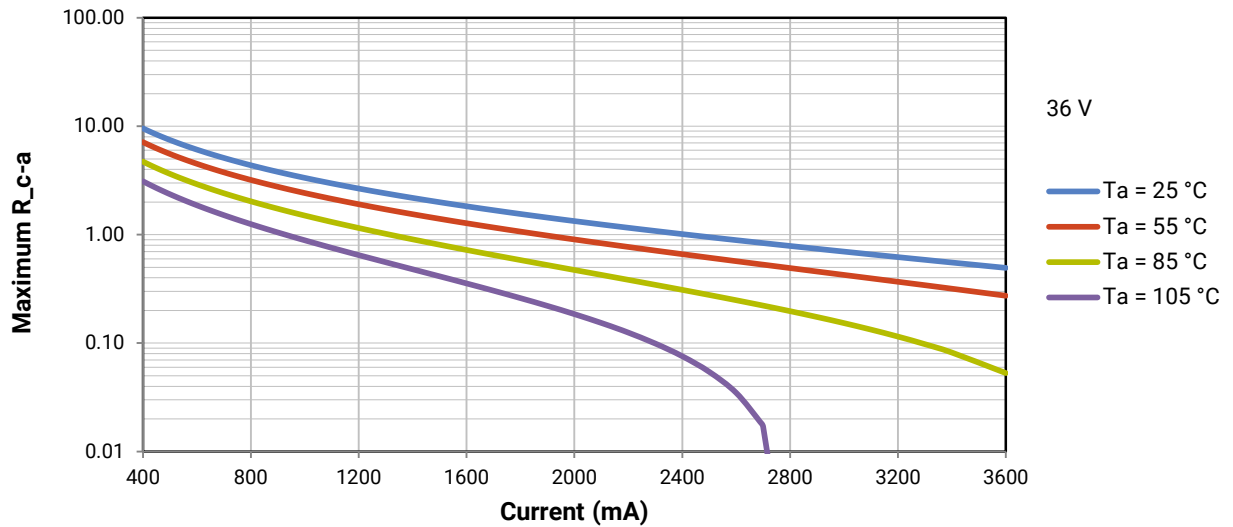
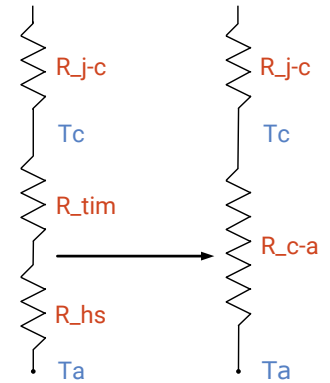

THERMAL DESIGN - CONTINUED

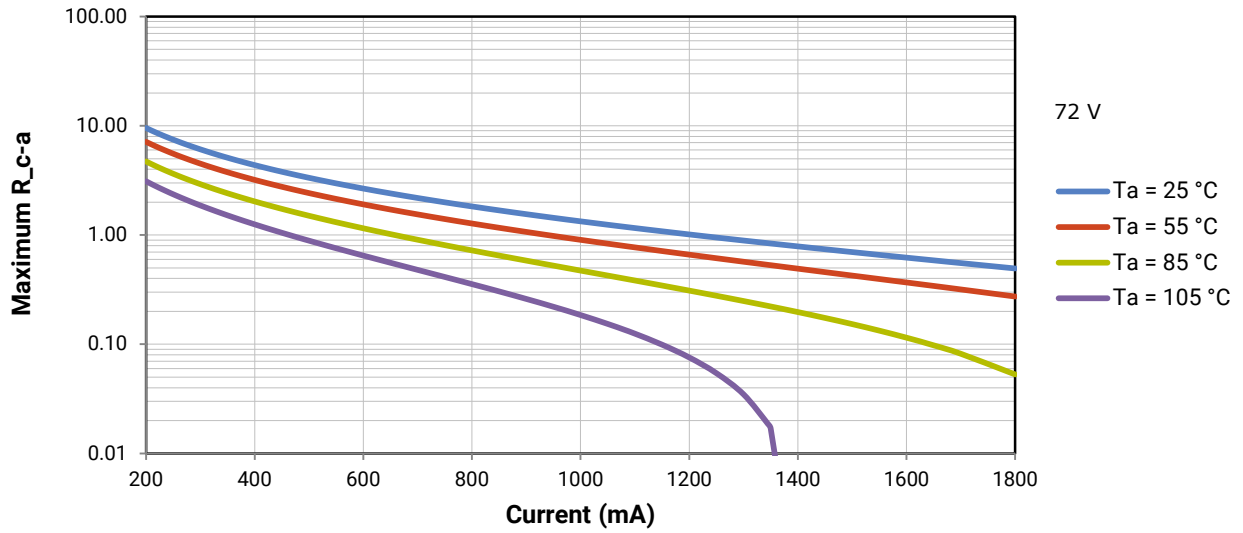

## NOTES

---

### Measurements

The luminous flux, radiant power, chromaticity, forward voltage and CRI measurements in this document are binning specifications only and solely represent product measurements as of the date of shipment. These measurements will change over time based on a number of factors that are not within Cree LED's control and are not intended or provided as operational specifications for the products. Calculated values are provided for informational purposes only and are not intended or provided as specifications.

### Pre-Release Qualification Testing

Please read the [LED Reliability Overview](#) for details of the qualification process Cree LED applies to ensure long-term reliability for XLamp LEDs and details of Cree LED's pre-release qualification testing for XLamp LEDs.

### Lumen Maintenance

Cree LED now uses standardized IES LM-80-08 and TM-21-11 methods for collecting long-term data and extrapolating LED lumen maintenance. For information on the specific LM-80 data sets available for this LED, refer to the public [LM-80 results document](#).

Please read the [Long-Term Lumen Maintenance application note](#) for more details on Cree LED's lumen maintenance testing and forecasting. Please read the [Thermal Management application note](#) for details on how thermal design, ambient temperature, and drive current affect the LED junction temperature.

### RoHS Compliance

The levels of RoHS restricted materials in this product are below the maximum concentration values (also referred to as the threshold limits) permitted for such substances, or are used in an exempted application, in accordance with EU Directive 2011/65/EC (RoHS2), as implemented January 2, 2013. RoHS Declarations for this product can be obtained from your Cree LED representative or from the [Product Ecology](#) section of the Cree LED website.

### REACH Compliance

REACH substances of very high concern (SVHCs) information is available for this product. Since the European Chemical Agency (ECHA) has published notice of their intent to frequently revise the SVHC listing for the foreseeable future, please contact a Cree LED representative to insure you get the most up-to-date REACH Declaration. REACH banned substance information (REACH Article 67) is also available upon request.

### UL® Recognized Component

This product meets the requirements to be considered a UL Recognized Component with Level 4 enclosure consideration. The LED package or a portion thereof has been investigated as a fire and electrical enclosure per ANSI/UL 8750.

### Vision Advisory

WARNING: Do not look at an exposed lamp in operation. Eye injury can result. For more information about LEDs and eye safety, please refer to the [LED Eye Safety application note](#).

**PACKAGING**

CXA3590 LEDs are packaged in trays of 10. Five trays are sealed in an anti-static bag and placed inside a carton, for a total of 50 LEDs per carton. Each carton contains 50 LEDs from the same performance bin.

Dimensions are in inches.  
Tolerances:  $\pm .13$   
 $x^\circ \pm 1^\circ$

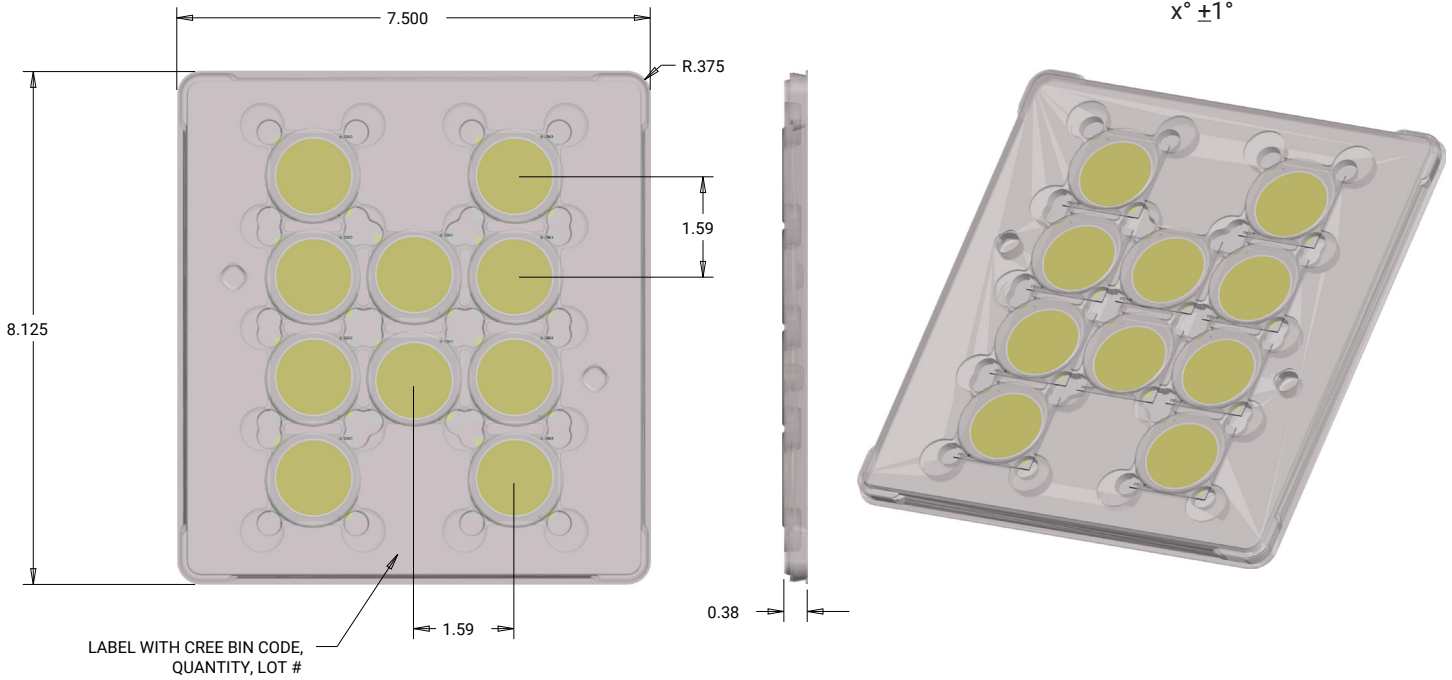

PATENT LABEL IS LOCATED ON UNDERSIDE OF CARTON

LABEL WITH CREE BIN CODE, QUANTITY, LOT #

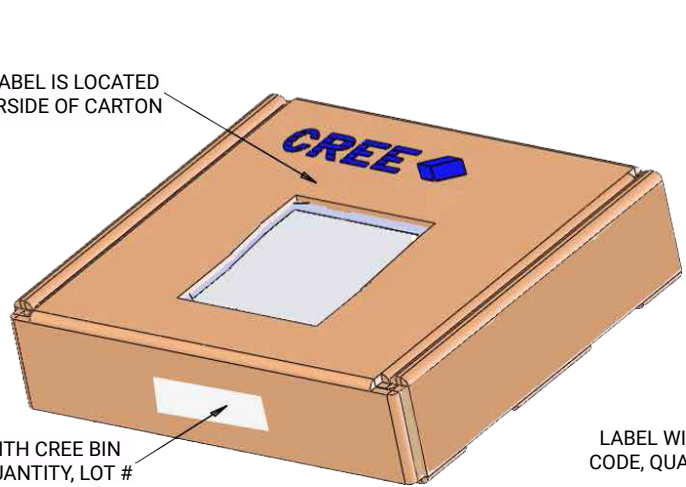

BAG

LABEL WITH CREE BIN CODE, QUANTITY, LOT #

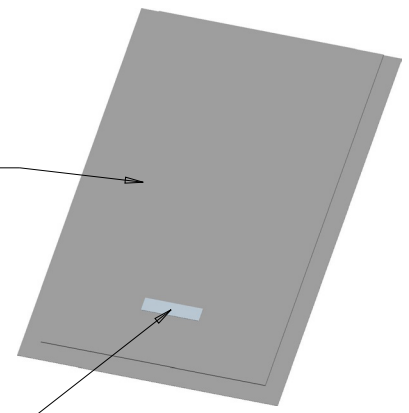

## Looking for pricing, stock, or lifecycle information?

Click below to explore more details on WIN SOURCE:

 [View CXA3590-0000-000R00AD27F on WIN SOURCE](#)

 [CreeLED, Inc. Information](#)

## Optimize Your Supply Chain with WIN SOURCE Solutions

-  Global Sourcing Solution
-  Obsolete Management
-  Cost Control Management
-  Shortage Management
-  Alternative Solution
-  Excess Inventory Management