

TRF3765 Integer/Fractional-N PLL With Integrated VCO Evaluation Module

This document describes usage and features of the TRF3765 evaluation module (EVM) for wideband frequency synthesis applications. The synthesizer uses an integer/fractional-N PLL with integrated VCOs to generate local oscillator signals from 300 MHz to 4800 MHz. This document describes rapid-start setup procedures, detailed descriptions of circuit blocks and available options, schematics and printed-circuit board layout, and a common start-up problem troubleshooting guide.

Contents

1	Quick-Start Operating Procedures	2
2	Circuit Block Descriptions	2
	2.1 Test Points	2
	2.2 Power Supply	3
	2.3 Loop Filter	3
	2.4 SPI Communication	4
	2.5 Reference Clock	4
3	Configuration Options	4
4	Physical Description	5
	4.1 Schematic	5
	4.2 Layout	8
	4.3 Bill of Materials	12
5	Troubleshooting FAQs	15

List of Figures

1	Loop Filter Reference Designators	4
2	TRF3765EVM Schematic, Page 1 of 3	5
3	TRF3765EVM Schematic, Page 2 of 3	6
4	TRF3765EVM Schematic, Page 3 of 3	7
5	Silkscreen, Top	8
6	Top Layer and Drill Map	9
7	Layer 2, Ground	10
8	Layer 3, Power	11
9	Bottom Layer and Silkscreen	12
10	Fabrication Drawing	12

List of Tables

1	Test Point Color Codes	2
2	Integer and Fractional Mode Configurations	5
3	Fractional Board Bill of Materials	12
4	Integer Board Bill of Materials, Differences from Fractional Board	14
5	Troubleshooting Sequences	15

1 Quick-Start Operating Procedures

The TRF3765 evaluation module (EVM) is preconfigured to use a 3.3-Vdc power supply on TP2. The supply must be capable of supplying 250 mA.

SPI communication is required for configuring the TRF3765 device. J7 accepts a mini-USB connector that can be driven through the device graphical user interface (GUI).

Local oscillator (LO) outputs are available in four differential pairs on SMA coaxial connectors J1, J3-J6, and J9-J11.

The following steps describe the EVM setup for basic operation with the default hardware configuration.

1. Connect the mini-USB connector. LED D1 draws power through the mini-USB connector and illuminates immediately.
2. Power the device by supplying TP2 with 3.3 V. Use TP3 for the ground connection. Board revisions prior to Revision D may require additional power supply connections.
3. Connect the LO output to measurement equipment.
4. Install and start the GUI software.
5. Initiate a communication link with the device by using the GUI Connect button. Follow on-screen instructions to load a register configuration file. Select file *TRF3765.FracMode.3p3Vtank.2600MHz.txt* for a fractional mode board and *TRF3765.IntMode.3p3Vtank.2600MHz.txt* for an integer mode board.
6. Verify lock-detect on LED D2 and the signal on measurement equipment. If D2 is not illuminated, no signal is present or the signal is at the incorrect frequency. Check GUI settings on any of the High Level tabs and recalibrate.
7. Using default hardware and configuration settings, fractional mode integrated phase noise is -47 dBc to -48 dBc/Hz, whereas integer mode integrated phase is -44 dBc/Hz.

2 Circuit Block Descriptions

This section describes each of the major circuit blocks and their configuration options.

2.1 Test Points

Test points are used throughout the board for control and monitoring. These test points are color-coded for quick reference. The color codes are described in [Table 1](#).

Table 1. Test Point Color Codes

Color	Group	Reference Designators
Black	Ground	TP1, TP3, TP4, TP11, TP14, TP27-TP30
White	Unregulated supply	TP2, TP24
Red	Unregulated supply	TP5
Purple	Regulated supply	TP25, TP26
Green	VCC and SPI monitor	TP6-TP10, TP12, TP13, TP19-TP23
Blue	VCC1 monitor	TP15-TP18

2.2 Power Supply

The TRF3765 uses three primary power supplies: VCC1, VCC2, and VCC3. In the default configuration, VCC1 and VCC2 are connected onboard by R41 and VCC3 is unused. The entire board can be supplied through 3.3 V on TP2 or Revision D boards. Earlier board revisions require multiple power connections.

A clean power supply is critical to optimal phase noise performance of the synthesizer. The impact of the power supply is discussed in detail in the application report *Supply Noise Effect on Oscillator Phase Noise* ([SLWA066](#)). Linear power supplies are the best sources available. Switching power supplies degrade in-band phase noise by 10 dB compared to linear laboratory supplies. Onboard regulators U3 and U4 are ultra-clean TPS74201 linear regulators that also provide excellent performance when they are driven by most laboratory power supply equipment. These regulators provide performance comparable to a clean linear supply. To use these regulated 3.3-V supplies, disconnect power from TP2 and remove R41. Connect 5 V to TP26, using TP27 for ground. Place jumpers on JP4 and JP5 to shunt jumper pins 1 and 2.

VCC3 can be used to drive VCC_TK, a 3.3-V/5-V tolerant supply on the TRF3765. VCC_TK is normally driven by the 3.3-V VCC2 supply, but some applications perform better with a 5-V supply on VCC_TK. To use VCC3 to drive VCC_TK at 5 V, move FB2 onto FB11. Populate R12 with a short. Then drive VCC3 through TP5 with a clean linear laboratory supply at 5 V.

VCC3 can also be driven at 5 V by onboard regulator U5. However, this regulator is not as clean as a linear laboratory supply, and some phase noise performance loss occurs. To use the VCC3 onboard 5-V regulator, drive TP25 with 6 V using TP28 for ground and place a jumper on JP1 to shunt jumper pins 1 and 2.

The TRF3765EVM includes a power supply filter. This filter can be used to reduce in-band frequency noise from a switching power supply so that an external supply can drive 5 V on VCC_TK. Phase noise performance using a high-quality laboratory switching power supply to drive VCC3 through TP5 is similar to performance measured using a linear supply. The filter is integrated on Rev. E and later boards. Rev. D and earlier boards include an external filter that is equipped with BNC connectors for a convenient connection with power supply banana jacks.

Each VCC pin on the TRF3765 connects to an individual test point. The test point may be used for monitoring. Because each supply pin is isolated through a ferrite bead, by lifting the ferrite bead these test points may also be used to drive single-device supply pins.

Spurs occurring in the LO signal at 60 kHz and 100 kHz offset from the carrier are usually the result of ground loops in power supply cabling.

2.3 Loop Filter

Loop-filter components are also critical to optimal phase noise performance. The loop filter must be matched to the selected phase frequency detector (PFD) frequency. TRF3765 boards are shipped with components matched to the onboard reference clock and configuration file. However, to use a different PFD frequency, the loop-filter components must be updated. The Loop Filter Design Tool available at [ti.com](#) in the TRF3765EVM product folder is an intuitive software package that identifies proper component values.

Loop filter reference designators are shown in [Figure 1](#). The assembly layout of these components is shown in a silkscreen blow-up on the EVM.

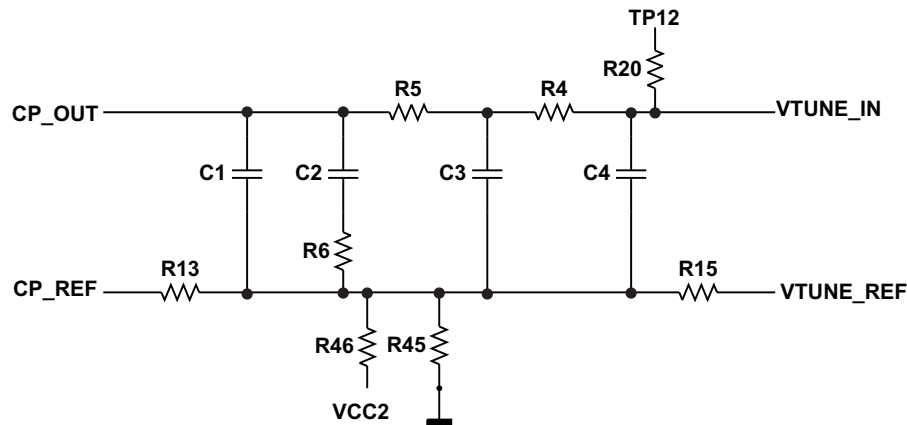

Figure 1. Loop Filter Reference Designators

VTune may be monitored on TP12 without disrupting circuit operation, because R20 is a high-value resistance. TP12 can also be used to drive VTune for open-loop VCO measurements when the TRF3765 charge pump is in 3-state logic. A 1- μ F capacitor on C4 is also recommended for open-loop measurements to help stabilize the applied voltage.

By default, reference is tied to ground through shorts on R13, R15, and R45, with R46 open.

2.4 SPI Communication

SPI communication from the TRF3765 GUI passes through mini-USB connector J7. The USB interface is decoded and encoded by U2 into SPI lines DATA, STROBE, CLK, and RDBK. U2 is powered through the USB connection instead of the board supply, and LED D1 indicates USB power is applied. Test points TP6–TP10 can be used to monitor SPI communication with laboratory equipment. The laboratory equipment must be set to high impedance so that it does not load the communication lines.

When the USB cable is disconnected, U2 I/Os are high impedance. In this case, TP6–TP10 can be used to directly drive the SPI lines.

The power-on reset default register settings in the TRF3765 do not correspond to a valid operational state. SPI initialization is required to operate the device. Once the registers have been initialized, the mini-USB cable may be disconnected without disrupting device operation. However, once the mini-USB has been reconnected, the link must be reestablished through the GUI Connect button on the Start Up tab. The link exists between the GUI computer and U2, so loss of power to the TRF3765 device does not require reestablishing the link. Loss of device power, however, does require re-initialization of the registers.

2.5 Reference Clock

An oscillator is installed on the TRF3765EVM to provide a reference clock to the device. JP2 installed provides supply voltage to the oscillator, whereas JP3 installed connects the oscillator output to the TRF3765. The oscillator frequency drifts over temperature and is not rated for the full TRF3765 temperature operating range, so temperature testing must use an external reference clock.

An external reference clock can be supplied through the SMA connector J8. When using an external reference clock, remove jumpers on JP2 and JP3. The external reference is ac-coupled to the TRF3765 input pin. An external reference can also be used to frequency-lock the device to laboratory equipment. Verify that any supplied reference clock has low phase noise.

3 Configuration Options

The TRF3765 evaluation module ships configured for either integer mode or fractional mode. Each configuration is designed to use different reference and PFD frequencies and also has the corresponding loop-filter components. Differences in integer mode and fractional mode boards are listed in [Table 2](#).

Table 2. Integer and Fractional Mode Configurations

Item	Fractional Mode	Integer Mode
Oscillator	Y1 frequency 61.44 MHz	Y1 frequency 40 MHz
Typical PFD frequency	30.72 MHz	1.6 MHz
Loop filter components	C20 = 2200 pF C19 = 22000 pF R6 = 475 Ω R5 = 475 Ω C14 = 220 pF R4 = 475 Ω C15 = 220 pF	C20 = 47 pF C19 = 560 pF R6 = 10 kΩ R5 = 5 kΩ C14 = 4.7 pF R4 = 0 Ω C15 = open
Configuration file	TRF3765.FracMode.3p3Vtank.2600MHz.txt	TRF3765.IntMode.3p3Vtank.2600MHz.txt

4 Physical Description

The TRF3765EVM is designed to be a high-performance platform for the TRF3765 device. This section describes the schematic, layout and stackup, and bill of materials corresponding to Revision D boards.

4.1 Schematic

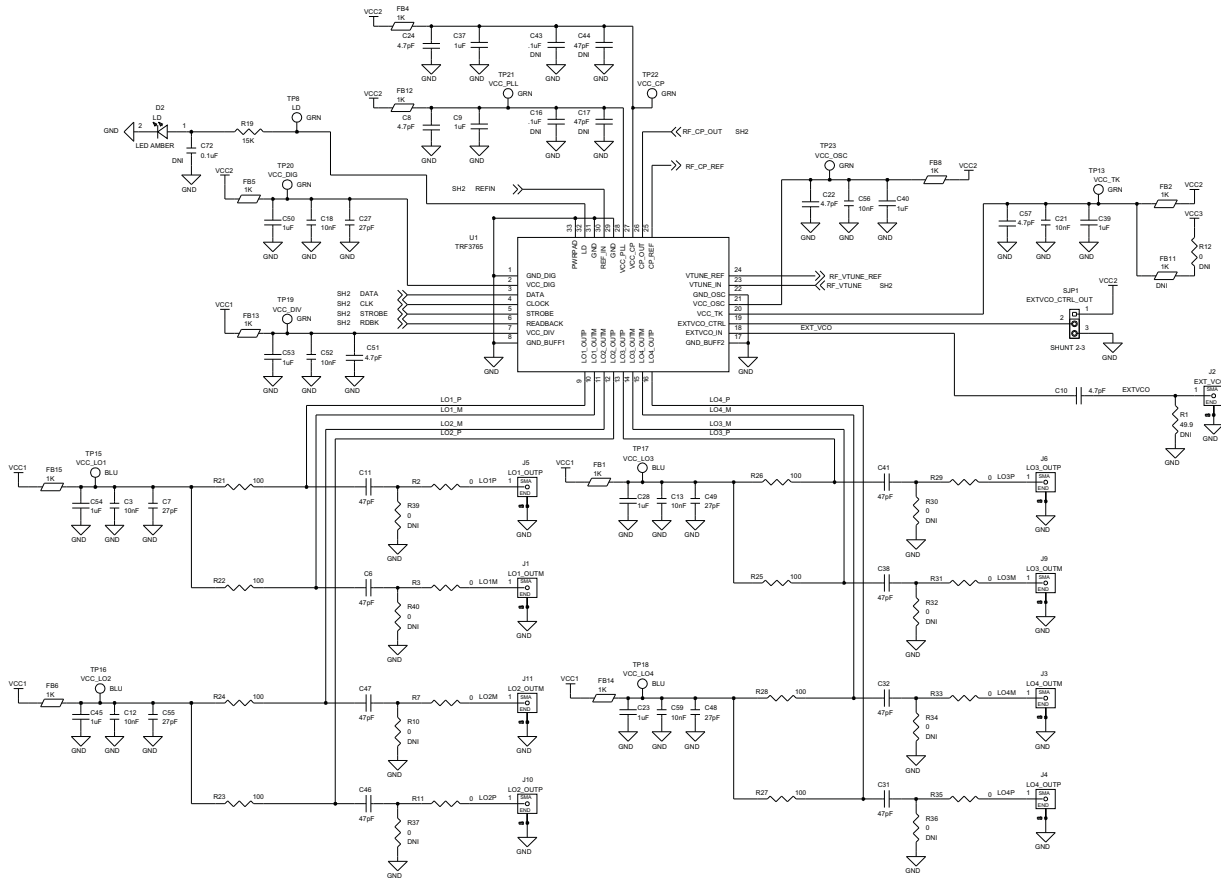

Figure 2. TRF3765EVM Schematic, Page 1 of 3

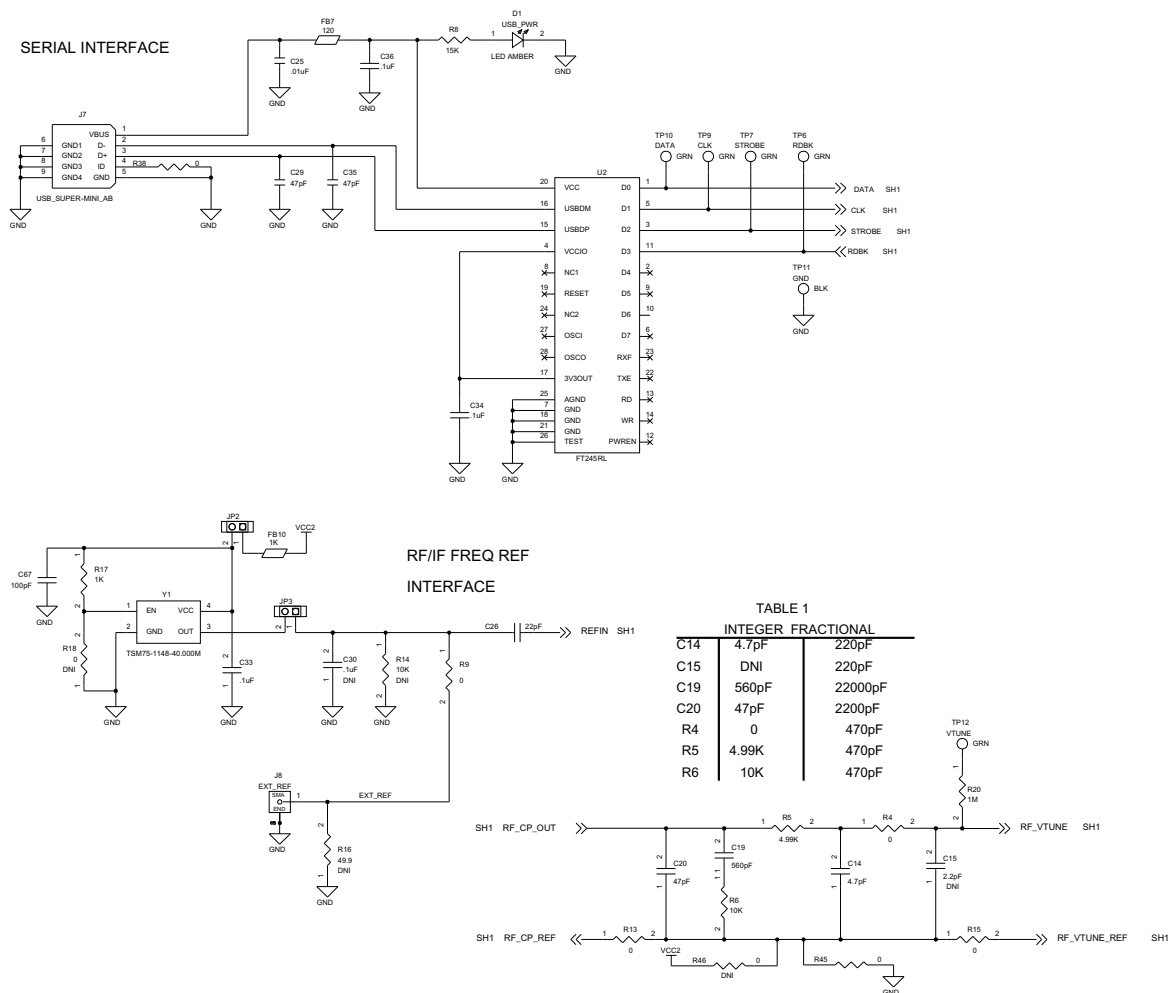

Figure 3. TRF3765EVM Schematic, Page 2 of 3

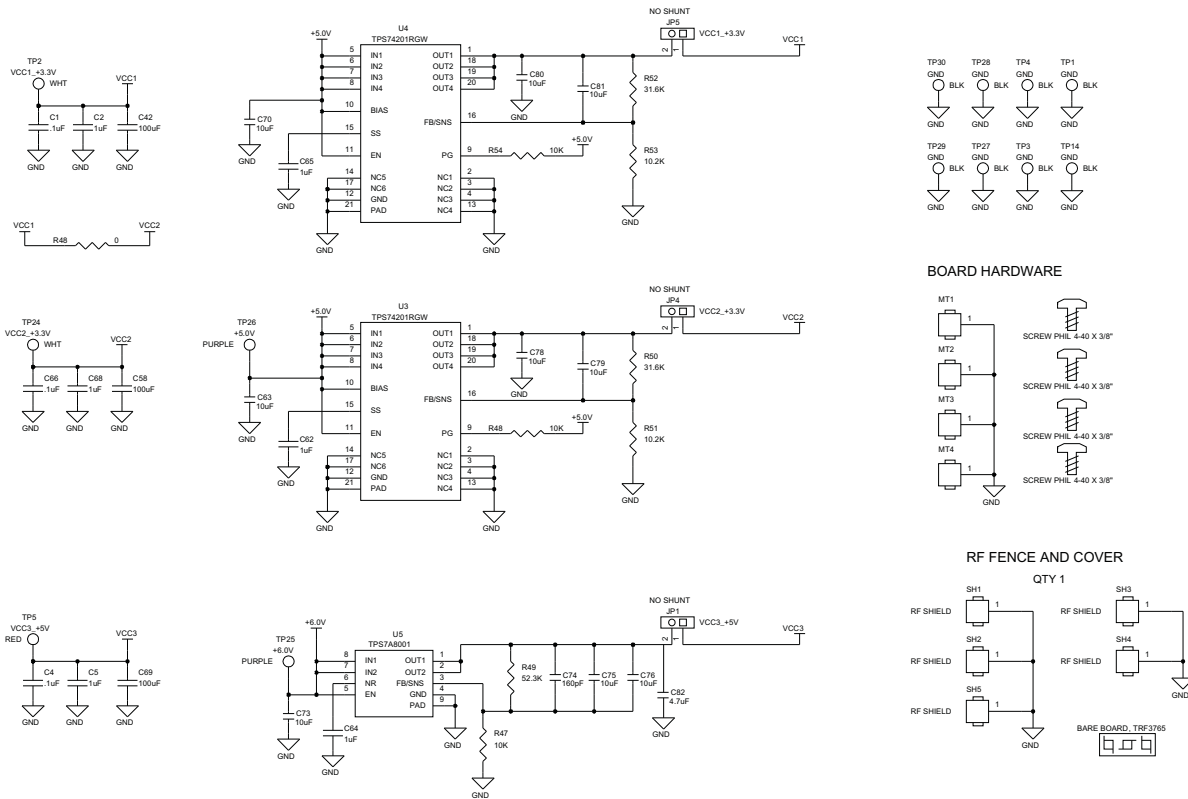

Figure 4. TRF3765EVM Schematic, Page 3 of 3

4.2 Layout

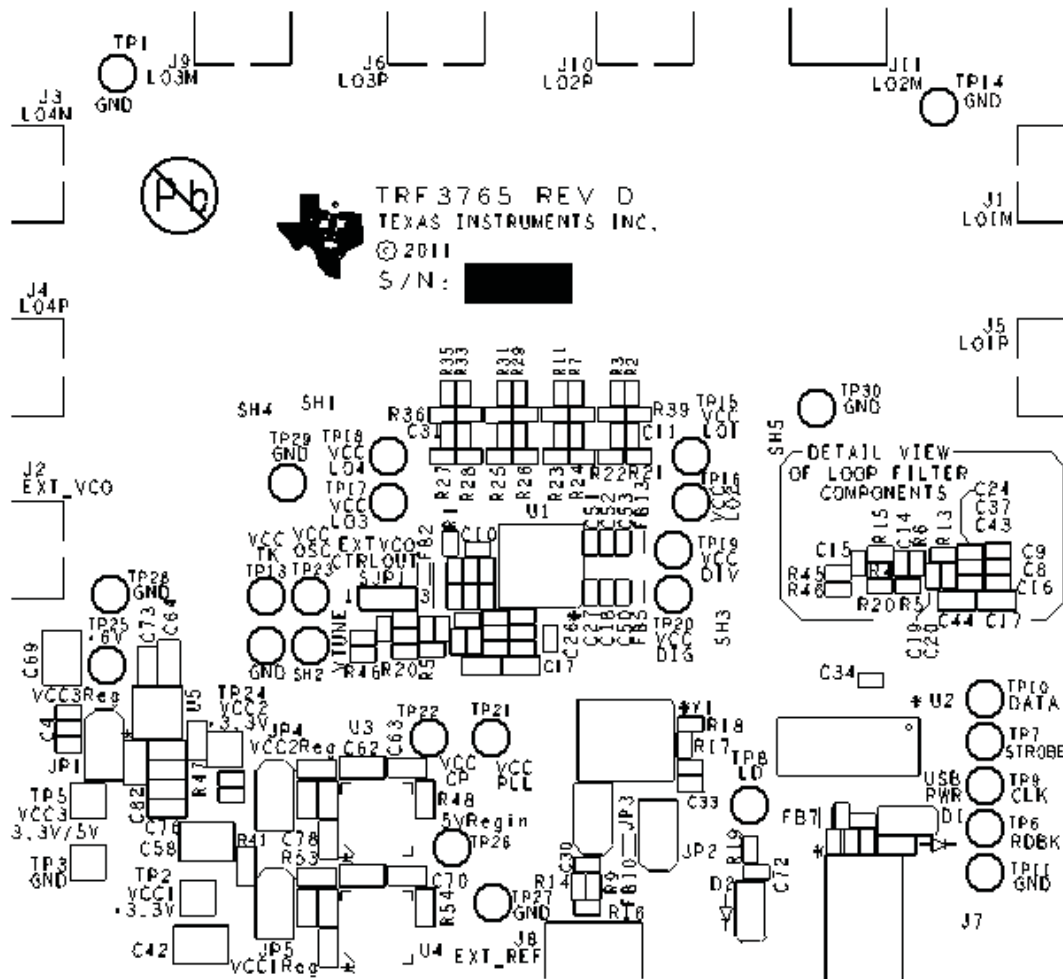

Figure 5. Silkscreen, Top

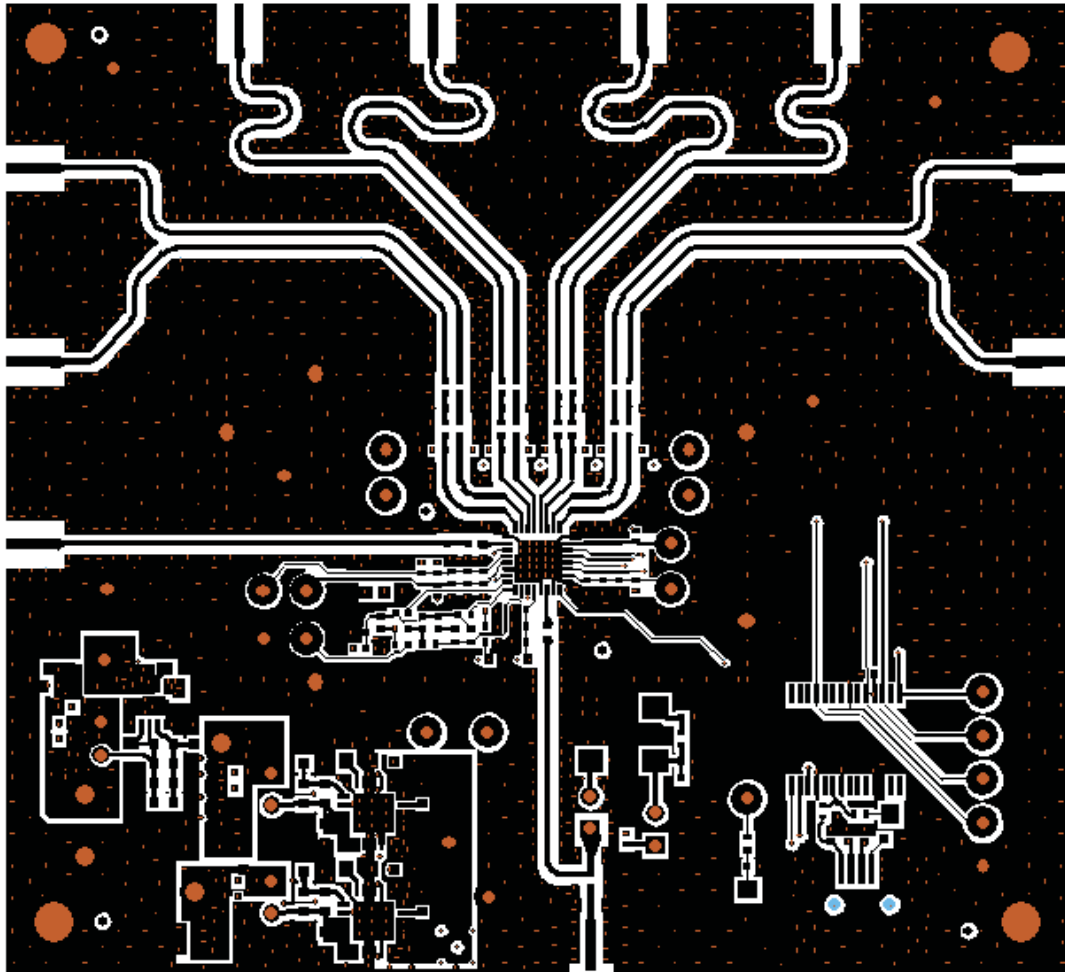

Figure 6. Top Layer and Drill Map

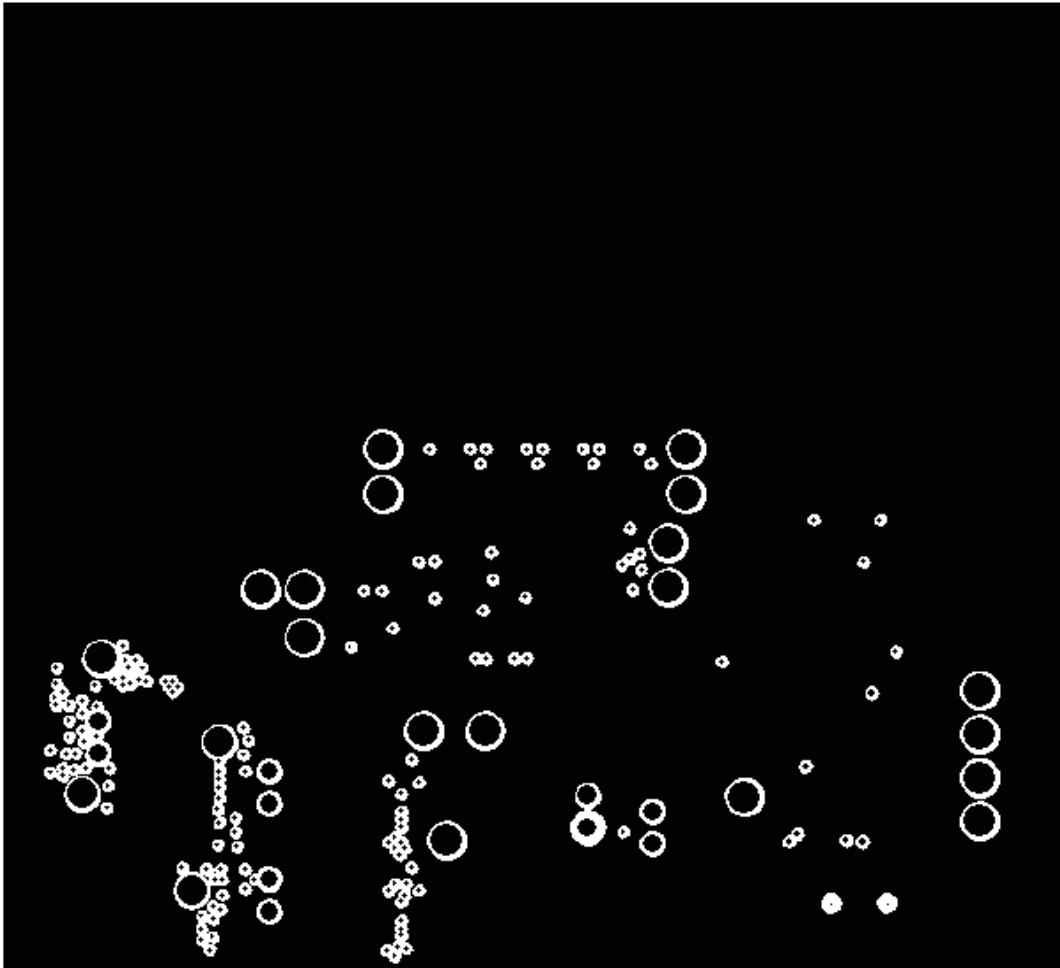

Figure 7. Layer 2, Ground

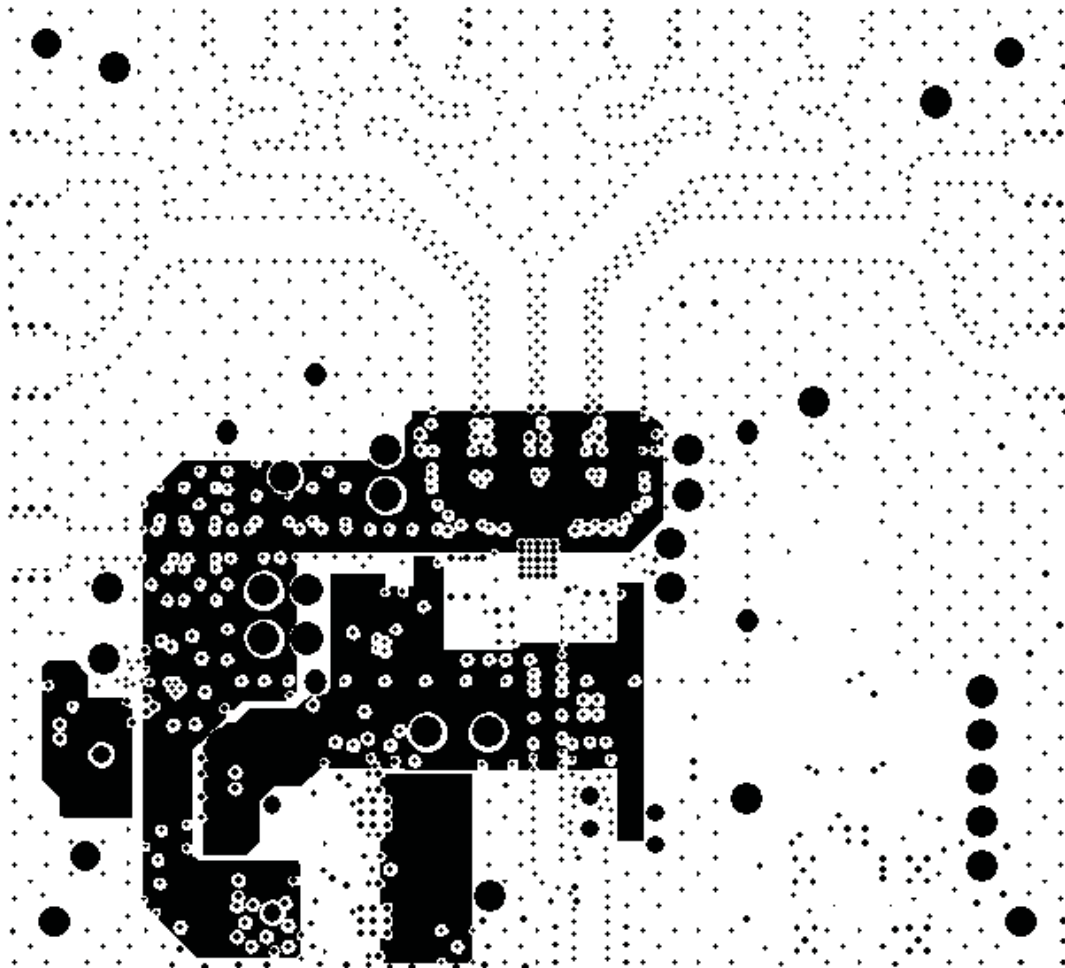

Figure 8. Layer 3, Power

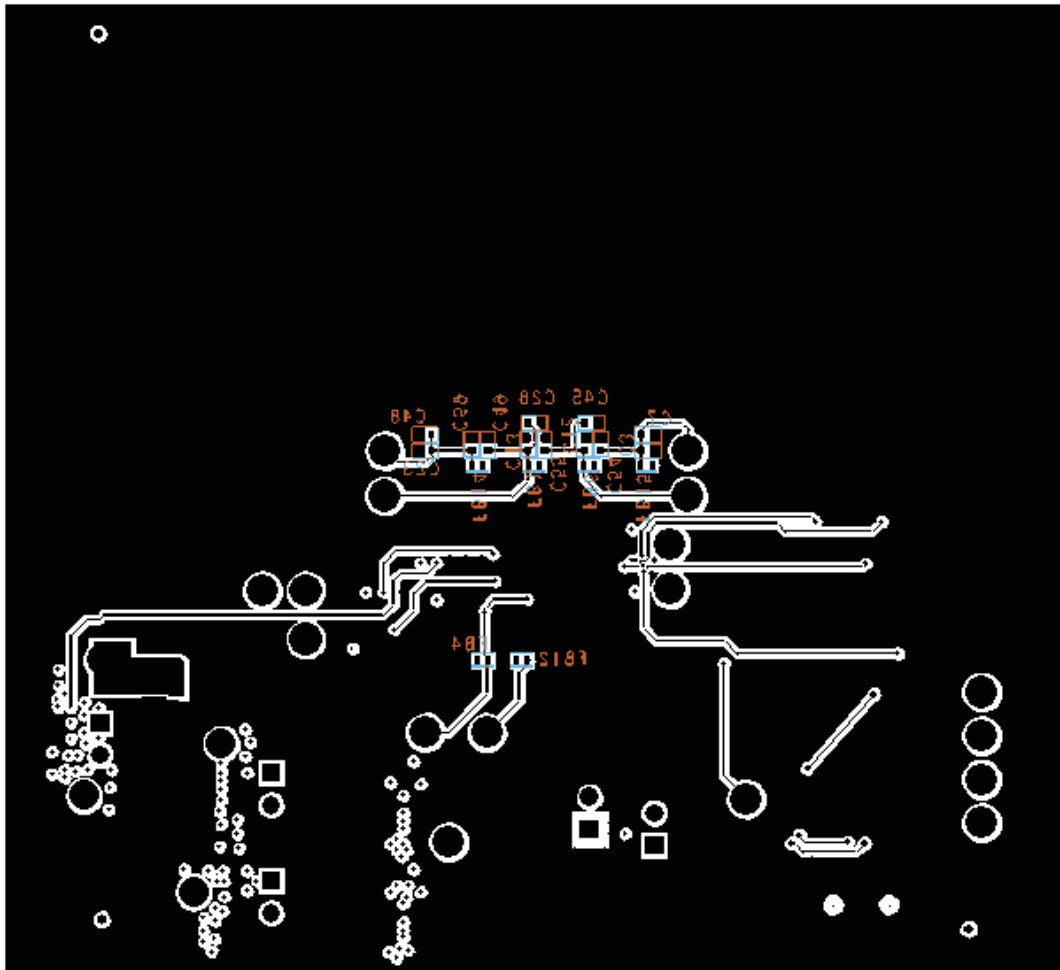

Figure 9. Bottom Layer and Silkscreen

Figure 10. Fabrication Drawing

4.3 Bill of Materials

Table 3. Fractional Board Bill of Materials

Item No.	Qty	Note	Part Reference	Value	PCB Footprint	Manufacturer	Manufacturer Part No.
1	6		C1, C4, C33, C34, C36, C66	0.1uF	0402	PANASONIC	ECJ-0EB1C104K
2	13		C2, C5, C9, C23, C28, C37, C39, C40, C45, C50, C53, C54, C68	1uF	0402	PANASONIC	ECJ-0EB1A105M
3	8		C3, C12, C13, C18, C21, C52, C56, C59	10nF	0402	MURATA	GRM155R71E103KA01D
4	8		C6, C11, C31, C32, C38, C41, C46, C47	47pF	0402	AVX CORP	GRM1555C1H470JZ01
5	5		C7, C27, C48, C49, C55	27pF	0402	AVX	04025A270JAT2A
6	6		C8, C10, C22, C24, C51, C57	4.7pF	0402	MURATA	GRM1555C1H4R7CZ01D
7	2		C14, C15	220pF	0402	AVX	04023A221JAT2A
8	1		C82	4.7uF	0805	TDK CORP	C2012X5R1A475K/0.86
9	0	DNI	C16, C30, C43	0.1uF	0402	PANASONIC	ECJ-0EB1A104K_DNI
10	0	DNI	C17, C44	47pF	0603	MURATA	GRM1885C1H470JA01D_DNI

Table 3. Fractional Board Bill of Materials (continued)

Item No.	Qty	Note	Part Reference	Value	PCB Footprint	Manufacturer	Manufacturer Part No.
11	1		C19	22000pF	0402	MURATA	GRM155R71C223KA01D
12	1		C20	2200pF	0402	AVX	04025C222JAT2A
13	2		C29, C35	47pF	0402	PANASONIC	ECJ-0EC1H470J
14	1		C25	0.01uF	0402	PANASONIC	ECJ-0EB1E103K
15	1		C26	22pF	0402	PANASONIC	ECJ-0EC1H220J
16	3		C42, C58, C69	100uF	1210	PANASONIC	ECJ-4YB0J107M
17	3		C62, C64, C65,	1uF	0805	TDK CORP	C2012X5R1E105K
18	9		C63, C70, C73, C75, C76, C78, C79, C80, C81	10uF	0603	MURATA	GRM188R60J106ME47D
19	1		C67	100pF	0402	MURATA	GRM1555C1H101JZ01D
20	0	DNI	C72	0.1uF	0402	PANASONIC	ECJ-0EB1A104K_DNI
21	1		C74	160pF	0603	TDK Corp	C1608C0G1H161J
22	2		D1, D2	LED AMBER	LED_0805	PANASONIC	LNJ406K54RX
23	11		FB1, FB2, FB4-FB6, FB8, FB10, FB12-FB15	1K	IND_0402	MURATA	BLM15AG102SN1
24	1		FB7	120	IND_0402	MURATA	BLM15AG121SNIB
25	0	DNI	FB11	1K	IND_0402	MURATA	BLM15AG102SN1_DNI
26	10		J1-J6, J8-J11	SMA_END_JACK	SMA_SMEL_250x215	Johnson Components	142-0711-821
7	1		J7	USB_SUPER-MINI_AB	CON_SMRT_USBMNE20_F	ACON	MNE20-5G5P10
28	5		JP1-JP5	JUMPER_1X2_100	HDR_THVT_1X2_100_M	SAMTEC	TSW-102-07-L-S
29	4		MT1-MT4	STANDOFF 4-40 X 0.500" ALUM	mfg125_plated	KEYSTONE	3480
30	0	DNI	R1 R16	49.9	0402	PANASONIC	ERJ-2RKF49R9X_DNI
31	12		R2, R3, R7, R9, R11, R13, R15, R29, R31, R33, R35, R45	0	0402	PANASONIC	ERJ-2GE0R00X
32	3		R4, R5, R6	470	0402	PANASONIC	ERJ-2RKF4700X
33	2		R8, R19	15K	0402	PANASONIC	ERJ-2GEJ153X
34	0	DNI	R10, R12, R18, R30, R32, R34, R36, R37, R39, R40, R46	0	0402	PANASONIC	ERJ-2GE0R00X_DNI
35	0	DNI	R14	10K	0402	PANASONIC	ERJ-2GEJ103X_DNI
36	1		R17	1K	0402	PANASONIC	ERJ-2GEJ102X
37	1		R20	1M	0402	PANASONIC	ERJ-2RKF1004X
38	8		R21, R22-R28	100	0402	PANASONIC	ERJ-2RKF1000X
39	2		R38, R41	0	0603	Panasonic	ERJ-3GEY0R00V
40	3		R47, R48, R54	10K	0603	PANASONIC	ERJ-3EKF1002V
41	1		R49	52.3K	0603	PANASONIC	ERJ-3EKF5232V
42	2		R50, R52	31.6K	0603	PANASONIC	ERJ-3EKF3162V
43	2		R51, R53	10.2K	0603	PANASONIC	ERJ-3EKF1022V
44	0	DNI	SH1-SH5	RF SHIELD	MFG053_PTH	LEADER TECH	SL-10797
45	0	DNI	SJP1	SOLDER JUMPER, 0603	SJP3_JUMPER	DNI	DNI
46	8		TP1, TP4, TP11, TP14, TP27- TP30	BLK	TP_THVT_100_RND	KEYSTONE	5001K
47	1		TP3	BLK	TESTPOINT_62DIA	KEYSTONE	5011K
48	2		TP2, TP24	WHT	TESTPOINT_62DIA	KEYSTONE	5012K
49	1		TP5	RED	TESTPOINT_62DIA	KEYSTONE	5010K
50	12		TP6-TP10, TP12, TP13, TP19-TP23	GRN	TP_THVT_100_RND	KEYSTONE	5116K
51	4		TP15-TP18	BLU	TP_THVT_100_RND	KEYSTONE	5117K
52	2		TP25, TP26	PURPLE	TP_THVT_100_RND	KEYSTONE	5119K
53	1		U1	TRF3765	QFN_32_197X197_20_PWRPAD	TI	TRF3765
54	1		U2	FT245RL	ssop_28_413x220_26	FTDI Chip	FT245RL
55	2		U3, U4	TPS74201RGW	QFN_20_199X199_0P65MM	TI	TPS74201RGW
56	1		U5	TPS7A8001	SON_8_3MMX3MM_0P65MM	TI	TPS7A8001DRB
57	1		Y1	TSM75-1148-61.440M	OSC_4_SM_295x197	Transko	TSM75-1148-61.440M
58	4			PHIL 4-40 X 3/8"		Building Fasteners	PMSSS 440 0038 PH
59	2	pins 1-2	FOR JP2 AND JP3	SHUNT		KELTRON	MJ-5.97-G OR EQUIVALENT

Table 3. Fractional Board Bill of Materials (continued)

Item No.	Qty	Note	Part Reference	Value	PCB Footprint	Manufacturer	Manufacturer Part No.
60	1	pins 2-3	FOR SJP1	SHUNT-JUMPER-0603		PANASONIC	ERJ-3GE0R00X

Table 4. Integer Board Bill of Materials, Differences from Fractional Board

Item No.	Qty	Note	Part Reference	Value	PCB Footprint	Manufacturer	Manufacturer Part No.
7	1		C14	4.7pF	0402	PANASONIC	ECD-G0E4R7B
8	0	DNI	C15	2.2pF	0402	PANASONIC	ECD-G0E2R2B
11	1		C19	560pF	0402	MURATA	GRM155R71H561KA01D
12	3		C20	47pF	0402	PANASONIC	ECJ-0EC1H470J
30	13		R4	0	0402	PANASONIC	ERJ-2GE0R00X
31	1		R5	4.99K	0402	PANASONIC	ERJ-2RKF4991X
32	1		R6	10K	0402	PANASONIC	ERJ-2RKF1002X
56	1		Y1	TSM75-1148-40.000M	OSC_4_SM_295x197	Transko	TSM75-1148-40.000M

5 Troubleshooting FAQs

This section provides troubleshooting sequences in [Table 5](#) to resolve several of the most frequently asked questions.

Table 5. Troubleshooting Sequences

Problem	Response
LD diode D2 won't light up	Verify that the loop filter components correspond to the programmed PFD frequency.
	Check power on device pin test points: TP12, TP13, TP19-TP23
	Verify that one refclk is applied, generated either onboard or offboard.
	Registers 1 to 6 must be initialized. Reload the start-up macro. Execute VCO calibration after initialization is complete.
	Fractional mode operation must set LD_ANA_PREC* at low precision (1).
	Verify GUI communication with the device. Readback value fields display nonzero hexadecimal values after a register is written. The GUI Low Level display allows direct register readback.
	Using the GUI Low Level tab, read registers. Verify that read ADDR bits are correct and that no N.U. bits have been initialized. Reset the device by removing power if a faulty address has been sent to the device or if any N.U. bits have been set.
	Measure voltage on TP8. Multimeter measurements below 2 V but above 0.5 V indicate toggling LD.
No readback from registers	Verify Cal_Clk frequency.
	High Level tab readback is supported on GUI revision 6 or later. Low Level readback is supported on all GUI releases.
	Prerelease device revisions may not support readback. Verify the device markings do not include a P prefix on the first line.
No LO output	On the GUI Start Up tab, Disconnect, verify that Simulate Connection is not selected, then Connect.
	Verify that the buffer is configured to be powered on by reading back register 4 on the GUI Low Level tab. 0 = on, and 1 = off.
	Verify that registers are successfully reading back from the device to confirm communication.
Spurs or unstable output frequency	Check power on device pin test points: TP12, TP13, TP19-TP23
	Verify that one refclk is applied, generated either onboard or offboard.
	Remove any monitoring equipment from the VTune tap on TP12.
	Verify that EN_DITH, EN_ISOURCE are set properly for integer or fractional mode. Verify VCO_BIAS is set properly for the applied VCC_TK voltage level. In fractional mode, verify that MOD_ORD is third (2) and DITH_SEL is Random (0).
Poor phase noise	Eliminate ground loops in power supplies.
	Verify that the installed loop filter corresponds to the applied refclk and PFD frequency.
	Verify that the power supply is clean and is not an unfiltered switching power supply.
	Revert the board to shipping hardware configuration, load a factory-supplied, start-up file, and verify phase noise against data sheet measurements.

EVALUATION BOARD/KIT/MODULE (EVM) ADDITIONAL TERMS

Texas Instruments (TI) provides the enclosed Evaluation Board/Kit/Module (EVM) under the following conditions:

The user assumes all responsibility and liability for proper and safe handling of the goods. Further, the user indemnifies TI from all claims arising from the handling or use of the goods.

Should this evaluation board/kit not meet the specifications indicated in the User's Guide, the board/kit may be returned within 30 days from the date of delivery for a full refund. THE FOREGOING LIMITED WARRANTY IS THE EXCLUSIVE WARRANTY MADE BY SELLER TO BUYER AND IS IN LIEU OF ALL OTHER WARRANTIES, EXPRESSED, IMPLIED, OR STATUTORY, INCLUDING ANY WARRANTY OF MERCHANTABILITY OR FITNESS FOR ANY PARTICULAR PURPOSE. EXCEPT TO THE EXTENT OF THE INDEMNITY SET FORTH ABOVE, NEITHER PARTY SHALL BE LIABLE TO THE OTHER FOR ANY INDIRECT, SPECIAL, INCIDENTAL, OR CONSEQUENTIAL DAMAGES.

Please read the User's Guide and, specifically, the Warnings and Restrictions notice in the User's Guide prior to handling the product. This notice contains important safety information about temperatures and voltages. For additional information on TI's environmental and/or safety programs, please visit www.ti.com/esh or contact TI.

No license is granted under any patent right or other intellectual property right of TI covering or relating to any machine, process, or combination in which such TI products or services might be or are used. TI currently deals with a variety of customers for products, and therefore our arrangement with the user is not exclusive. TI assumes no liability for applications assistance, customer product design, software performance, or infringement of patents or services described herein.

REGULATORY COMPLIANCE INFORMATION

As noted in the EVM User's Guide and/or EVM itself, this EVM and/or accompanying hardware may or may not be subject to the Federal Communications Commission (FCC) and Industry Canada (IC) rules.

For EVMs **not** subject to the above rules, this evaluation board/kit/module is intended for use for ENGINEERING DEVELOPMENT, DEMONSTRATION OR EVALUATION PURPOSES ONLY and is not considered by TI to be a finished end product fit for general consumer use. It generates, uses, and can radiate radio frequency energy and has not been tested for compliance with the limits of computing devices pursuant to part 15 of FCC or ICES-003 rules, which are designed to provide reasonable protection against radio frequency interference. Operation of the equipment may cause interference with radio communications, in which case the user at his own expense will be required to take whatever measures may be required to correct this interference.

General Statement for EVMs including a radio

User Power/Frequency Use Obligations: This radio is intended for development/professional use only in legally allocated frequency and power limits. Any use of radio frequencies and/or power availability of this EVM and its development application(s) must comply with local laws governing radio spectrum allocation and power limits for this evaluation module. It is the user's sole responsibility to only operate this radio in legally acceptable frequency space and within legally mandated power limitations. Any exceptions to this are strictly prohibited and unauthorized by Texas Instruments unless user has obtained appropriate experimental/development licenses from local regulatory authorities, which is responsibility of user including its acceptable authorization.

For EVMs annotated as FCC – FEDERAL COMMUNICATIONS COMMISSION Part 15 Compliant

Caution

This device complies with part 15 of the FCC Rules. Operation is subject to the following two conditions: (1) This device may not cause harmful interference, and (2) this device must accept any interference received, including interference that may cause undesired operation.

Changes or modifications not expressly approved by the party responsible for compliance could void the user's authority to operate the equipment.

FCC Interference Statement for Class A EVM devices

This equipment has been tested and found to comply with the limits for a Class A digital device, pursuant to part 15 of the FCC Rules. These limits are designed to provide reasonable protection against harmful interference when the equipment is operated in a commercial environment. This equipment generates, uses, and can radiate radio frequency energy and, if not installed and used in accordance with the instruction manual, may cause harmful interference to radio communications. Operation of this equipment in a residential area is likely to cause harmful interference in which case the user will be required to correct the interference at his own expense.

FCC Interference Statement for Class B EVM devices

This equipment has been tested and found to comply with the limits for a Class B digital device, pursuant to part 15 of the FCC Rules. These limits are designed to provide reasonable protection against harmful interference in a residential installation. This equipment generates, uses and can radiate radio frequency energy and, if not installed and used in accordance with the instructions, may cause harmful interference to radio communications. However, there is no guarantee that interference will not occur in a particular installation. If this equipment does cause harmful interference to radio or television reception, which can be determined by turning the equipment off and on, the user is encouraged to try to correct the interference by one or more of the following measures:

- Reorient or relocate the receiving antenna.
- Increase the separation between the equipment and receiver.
- Connect the equipment into an outlet on a circuit different from that to which the receiver is connected.
- Consult the dealer or an experienced radio/TV technician for help.

For EVMs annotated as IC – INDUSTRY CANADA Compliant

This Class A or B digital apparatus complies with Canadian ICES-003.

Changes or modifications not expressly approved by the party responsible for compliance could void the user's authority to operate the equipment.

Concerning EVMs including radio transmitters

This device complies with Industry Canada licence-exempt RSS standard(s). Operation is subject to the following two conditions: (1) this device may not cause interference, and (2) this device must accept any interference, including interference that may cause undesired operation of the device.

Concerning EVMs including detachable antennas

Under Industry Canada regulations, this radio transmitter may only operate using an antenna of a type and maximum (or lesser) gain approved for the transmitter by Industry Canada. To reduce potential radio interference to other users, the antenna type and its gain should be so chosen that the equivalent isotropically radiated power (e.i.r.p.) is not more than that necessary for successful communication.

This radio transmitter has been approved by Industry Canada to operate with the antenna types listed in the user guide with the maximum permissible gain and required antenna impedance for each antenna type indicated. Antenna types not included in this list, having a gain greater than the maximum gain indicated for that type, are strictly prohibited for use with this device.

Cet appareil numérique de la classe A ou B est conforme à la norme NMB-003 du Canada.

Les changements ou les modifications pas expressément approuvés par la partie responsable de la conformité ont pu vider l'autorité de l'utilisateur pour actionner l'équipement.

Concernant les EVMs avec appareils radio

Le présent appareil est conforme aux CNR d'Industrie Canada applicables aux appareils radio exempts de licence. L'exploitation est autorisée aux deux conditions suivantes : (1) l'appareil ne doit pas produire de brouillage, et (2) l'utilisateur de l'appareil doit accepter tout brouillage radioélectrique subi, même si le brouillage est susceptible d'en compromettre le fonctionnement.

Concernant les EVMs avec antennes détachables

Conformément à la réglementation d'Industrie Canada, le présent émetteur radio peut fonctionner avec une antenne d'un type et d'un gain maximal (ou inférieur) approuvé pour l'émetteur par Industrie Canada. Dans le but de réduire les risques de brouillage radioélectrique à l'intention des autres utilisateurs, il faut choisir le type d'antenne et son gain de sorte que la puissance isotrope rayonnée équivalente (p.i.r.e.) ne dépasse pas l'intensité nécessaire à l'établissement d'une communication satisfaisante.

Le présent émetteur radio a été approuvé par Industrie Canada pour fonctionner avec les types d'antenne énumérés dans le manuel d'usage et ayant un gain admissible maximal et l'impédance requise pour chaque type d'antenne. Les types d'antenne non inclus dans cette liste, ou dont le gain est supérieur au gain maximal indiqué, sont strictement interdits pour l'exploitation de l'émetteur.

【Important Notice for Users of this Product in Japan】

This development kit is NOT certified as Confirming to Technical Regulations of Radio Law of Japan

If you use this product in Japan, you are required by Radio Law of Japan to follow the instructions below with respect to this product:

1. Use this product in a shielded room or any other test facility as defined in the notification #173 issued by Ministry of Internal Affairs and Communications on March 28, 2006, based on Sub-section 1.1 of Article 6 of the Ministry's Rule for Enforcement of Radio Law of Japan,
2. Use this product only after you obtained the license of Test Radio Station as provided in Radio Law of Japan with respect to this product, or
3. Use of this product only after you obtained the Technical Regulations Conformity Certification as provided in Radio Law of Japan with respect to this product. Also, please do not transfer this product, unless you give the same notice above to the transferee. Please note that if you could not follow the instructions above, you will be subject to penalties of Radio Law of Japan.

Texas Instruments Japan Limited
(address) 24-1, Nishi-Shinjuku 6 chome, Shinjuku-ku, Tokyo, Japan

<http://www.tij.co.jp>

【ご使用にあたっての注】

本開発キットは技術基準適合証明を受けておりません。

本製品のご使用に際しては、電波法遵守のため、以下のいずれかの措置を取っていただく必要がありますのでご注意ください。

1. 電波法施行規則第6条第1項第1号に基づく平成18年3月28日総務省告示第173号で定められた電波暗室等の試験設備でご使用いただく。
2. 実験局の免許を取得後ご使用いただく。
3. 技術基準適合証明を取得後ご使用いただく。

なお、本製品は、上記の「ご使用にあたっての注意」を譲渡先、移転先に通知しない限り、譲渡、移転できないものとします。

上記を遵守頂けない場合は、電波法の罰則が適用される可能性があることをご留意ください。

日本テキサス・インスツルメンツ株式会社
東京都新宿区西新宿6丁目24番1号
西新宿三井ビル

<http://www.tij.co.jp>

EVALUATION BOARD/KIT/MODULE (EVM) WARNINGS, RESTRICTIONS AND DISCLAIMERS

For Feasibility Evaluation Only, in Laboratory/Development Environments. Unless otherwise indicated, this EVM is not a finished electrical equipment and not intended for consumer use. It is intended solely for use for preliminary feasibility evaluation in laboratory/development environments by technically qualified electronics experts who are familiar with the dangers and application risks associated with handling electrical mechanical components, systems and subsystems. It should not be used as all or part of a finished end product.

Your Sole Responsibility and Risk. You acknowledge, represent and agree that:

1. You have unique knowledge concerning Federal, State and local regulatory requirements (including but not limited to Food and Drug Administration regulations, if applicable) which relate to your products and which relate to your use (and/or that of your employees, affiliates, contractors or designees) of the EVM for evaluation, testing and other purposes.
2. You have full and exclusive responsibility to assure the safety and compliance of your products with all such laws and other applicable regulatory requirements, and also to assure the safety of any activities to be conducted by you and/or your employees, affiliates, contractors or designees, using the EVM. Further, you are responsible to assure that any interfaces (electronic and/or mechanical) between the EVM and any human body are designed with suitable isolation and means to safely limit accessible leakage currents to minimize the risk of electrical shock hazard.
3. You will employ reasonable safeguards to ensure that your use of the EVM will not result in any property damage, injury or death, even if the EVM should fail to perform as described or expected.
4. You will take care of proper disposal and recycling of the EVM's electronic components and packing materials.

Certain Instructions. It is important to operate this EVM within TI's recommended specifications and environmental considerations per the user guidelines. Exceeding the specified EVM ratings (including but not limited to input and output voltage, current, power, and environmental ranges) may cause property damage, personal injury or death. If there are questions concerning these ratings please contact a TI field representative prior to connecting interface electronics including input power and intended loads. Any loads applied outside of the specified output range may result in unintended and/or inaccurate operation and/or possible permanent damage to the EVM and/or interface electronics. Please consult the EVM User's Guide prior to connecting any load to the EVM output. If there is uncertainty as to the load specification, please contact a TI field representative. During normal operation, some circuit components may have case temperatures greater than 60°C as long as the input and output are maintained at a normal ambient operating temperature. These components include but are not limited to linear regulators, switching transistors, pass transistors, and current sense resistors which can be identified using the EVM schematic located in the EVM User's Guide. When placing measurement probes near these devices during normal operation, please be aware that these devices may be very warm to the touch. As with all electronic evaluation tools, only qualified personnel knowledgeable in electronic measurement and diagnostics normally found in development environments should use these EVMs.

Agreement to Defend, Indemnify and Hold Harmless. You agree to defend, indemnify and hold TI, its licensors and their representatives harmless from and against any and all claims, damages, losses, expenses, costs and liabilities (collectively, "Claims") arising out of or in connection with any use of the EVM that is not in accordance with the terms of the agreement. This obligation shall apply whether Claims arise under law of tort or contract or any other legal theory, and even if the EVM fails to perform as described or expected.

Safety-Critical or Life-Critical Applications. If you intend to evaluate the components for possible use in safety critical applications (such as life support) where a failure of the TI product would reasonably be expected to cause severe personal injury or death, such as devices which are classified as FDA Class III or similar classification, then you must specifically notify TI of such intent and enter into a separate Assurance and Indemnity Agreement.

Mailing Address: Texas Instruments, Post Office Box 655303, Dallas, Texas 75265
Copyright © 2012, Texas Instruments Incorporated

IMPORTANT NOTICE

Texas Instruments Incorporated and its subsidiaries (TI) reserve the right to make corrections, modifications, enhancements, improvements, and other changes to its products and services at any time and to discontinue any product or service without notice. Customers should obtain the latest relevant information before placing orders and should verify that such information is current and complete. All products are sold subject to TI's terms and conditions of sale supplied at the time of order acknowledgment.

TI warrants performance of its hardware products to the specifications applicable at the time of sale in accordance with TI's standard warranty. Testing and other quality control techniques are used to the extent TI deems necessary to support this warranty. Except where mandated by government requirements, testing of all parameters of each product is not necessarily performed.

TI assumes no liability for applications assistance or customer product design. Customers are responsible for their products and applications using TI components. To minimize the risks associated with customer products and applications, customers should provide adequate design and operating safeguards.

TI does not warrant or represent that any license, either express or implied, is granted under any TI patent right, copyright, mask work right, or other TI intellectual property right relating to any combination, machine, or process in which TI products or services are used. Information published by TI regarding third-party products or services does not constitute a license from TI to use such products or services or a warranty or endorsement thereof. Use of such information may require a license from a third party under the patents or other intellectual property of the third party, or a license from TI under the patents or other intellectual property of TI.

Reproduction of TI information in TI data books or data sheets is permissible only if reproduction is without alteration and is accompanied by all associated warranties, conditions, limitations, and notices. Reproduction of this information with alteration is an unfair and deceptive business practice. TI is not responsible or liable for such altered documentation. Information of third parties may be subject to additional restrictions.

Resale of TI products or services with statements different from or beyond the parameters stated by TI for that product or service voids all express and any implied warranties for the associated TI product or service and is an unfair and deceptive business practice. TI is not responsible or liable for any such statements.

TI products are not authorized for use in safety-critical applications (such as life support) where a failure of the TI product would reasonably be expected to cause severe personal injury or death, unless officers of the parties have executed an agreement specifically governing such use. Buyers represent that they have all necessary expertise in the safety and regulatory ramifications of their applications, and acknowledge and agree that they are solely responsible for all legal, regulatory and safety-related requirements concerning their products and any use of TI products in such safety-critical applications, notwithstanding any applications-related information or support that may be provided by TI. Further, Buyers must fully indemnify TI and its representatives against any damages arising out of the use of TI products in such safety-critical applications.

TI products are neither designed nor intended for use in military/aerospace applications or environments unless the TI products are specifically designated by TI as military-grade or "enhanced plastic." Only products designated by TI as military-grade meet military specifications. Buyers acknowledge and agree that any such use of TI products which TI has not designated as military-grade is solely at the Buyer's risk, and that they are solely responsible for compliance with all legal and regulatory requirements in connection with such use.

TI products are neither designed nor intended for use in automotive applications or environments unless the specific TI products are designated by TI as compliant with ISO/TS 16949 requirements. Buyers acknowledge and agree that, if they use any non-designated products in automotive applications, TI will not be responsible for any failure to meet such requirements.

Following are URLs where you can obtain information on other Texas Instruments products and application solutions:

Products

Audio	www.ti.com/audio
Amplifiers	amplifier.ti.com
Data Converters	dataconverter.ti.com
DLP® Products	www.dlp.com
DSP	dsp.ti.com
Clocks and Timers	www.ti.com/clocks
Interface	interface.ti.com
Logic	logic.ti.com
Power Mgmt	power.ti.com
Microcontrollers	microcontroller.ti.com
RFID	www.ti-rfid.com
OMAP Mobile Processors	www.ti.com/omap
Wireless Connectivity	www.ti.com/wirelessconnectivity

Applications

Automotive and Transportation	www.ti.com/automotive
Communications and Telecom	www.ti.com/communications
Computers and Peripherals	www.ti.com/computers
Consumer Electronics	www.ti.com/consumer-apps
Energy and Lighting	www.ti.com/energy
Industrial	www.ti.com/industrial
Medical	www.ti.com/medical
Security	www.ti.com/security
Space, Avionics and Defense	www.ti.com/space-avionics-defense
Video and Imaging	www.ti.com/video

TI E2E Community Home Page

e2e.ti.com

Mailing Address: Texas Instruments, Post Office Box 655303, Dallas, Texas 75265
Copyright © 2012, Texas Instruments Incorporated

Looking for pricing, stock, or lifecycle information?

Click below to explore more details on WIN SOURCE:

 [View TRF3765EVM-F on WIN SOURCE](#)

 [Texas Instruments](#) Information

Optimize Your Supply Chain with WIN SOURCE Solutions

-  Global Sourcing Solution
-  Obsolete Management
-  Cost Control Management
-  Shortage Management
-  Alternative Solution
-  Excess Inventory Management