



# THE DATASHEET OF DS56U





# DS56 Dual Temperature Comparator

www.dalsemi.com

## FEATURES

- Factory calibrated for sensitivity of +6.20 mV/°C and thermometer accuracy of  $\pm 2.0^\circ\text{C}$  over the  $0^\circ\text{C}$  to  $85^\circ\text{C}$  range and  $\pm 3^\circ\text{C}$  over the  $40^\circ\text{C}$  to  $0^\circ\text{C}$  and  $+85^\circ\text{C}$  to  $+125^\circ\text{C}$  range
- Measurement range of  $-40^\circ\text{C}$  to  $+125^\circ\text{C}$
- Integrated temperature sensor and voltage reference
- Two independent temperature setpoints with respective logic outputs with set hysteresis
- Narrow-body SO8 (150-mil) package
- Wide power supply range ( $2.7\text{V} \leq V_{\text{DD}} \leq 5.5\text{V}$ )
- Functionally compatible with LM56xIM
- Applications include monitoring disk drives, printers, office equipment, HVAC, appliances, or any power/cost/temperature-sensitive environments.

## PIN ASSIGNMENT

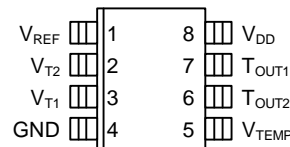

DS56S 8-Pin SOIC (150-mil)

## PIN DESCRIPTION

$V_{\text{REF}}$	- Bandgap Voltage Reference Output
$V_{\text{T2}}$	- Temperature Trip Point 2
$V_{\text{T1}}$	- Temperature Trip Point 1
GND	- Ground
$V_{\text{TEMP}}$	- Temp Sensor Output Voltage
$T_{\text{OUT2}}$	- Thermostat output for Trip Point 2
$T_{\text{OUT1}}$	- Thermostat output for Trip Point 1
$V_{\text{DD}}$	- Power Supply Voltage (2.7V to 5.5V)

## DESCRIPTION

The DS56 Dual Temperature Comparator has two independent open-drain thermostat outputs and respective trip point inputs. The trip points are set with external resistors that divide down the 1.25V internal bandgap voltage reference. The voltage resulting from this resistive division is compared with the voltage corresponding to the device's junction temperature to define the thermostat output logic state. The internal temperature sensor has a typical sensitivity of +6.2mV/°C and DC offset of +395 mV at  $0^\circ\text{C}$ . Both thermostat outputs have  $5^\circ\text{C}$  of hysteresis.

For applications that require temperature measurement as well as control, the temperature sensor voltage is brought out to a pin.

The DS56 is packaged in a compact 150-mil, 8-pin SOIC. Applications include disk drives, printers, office equipment, HVAC, appliances, or any power/cost/temperature-sensitive environments.

**DETAILED PIN DESCRIPTION Table 1**

PIN	SYMBOL	TYPE	DESCRIPTION
1	$V_{REF}$	Analog output	<b>Bandgap output</b> 1.25V (nom) voltage reference output.
2	$V_{T2}$	Analog input	<b>Trip point 2</b> input associated with thermostat output 2.
3	$V_{T1}$	Analog input	<b>Trip point 1</b> input associated with thermostat output 1.
4	GND	GND	<b>Ground pin.</b>
5	$V_{TEMP}$	Analog output	<b>Temperature sensor output.</b> $(+6.2 T_{DegC} + 395)$ mV.
6	$T_{OUT2}$	Digital output (open-drain)	<b>Thermostat output 2.</b> Active low output corresponding to trip point 2. Typical hysteresis is 5.0°C.
7	$T_{OUT1}$	Digital output (open-drain)	<b>Thermostat output 1.</b> Active low output corresponding to trip point 1. Typical hysteresis is 5.0°C.
8	$V_{DD}$	$V_{DD}$	<b>Supply Voltage</b> 2.7V - 5.5V input power pin.

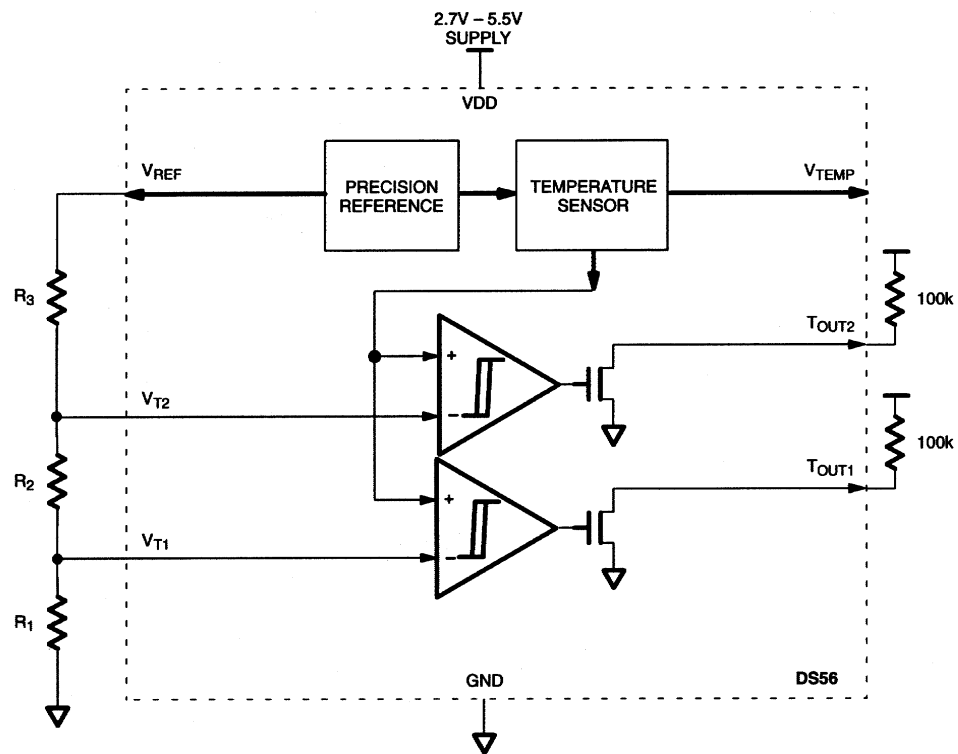
**DS56 FUNCTIONAL BLOCK DIAGRAM Figure 1**

## OVERVIEW

A block diagram of the DS56 is shown in Figure 1. The DS56 consists of three major components:

1. Precision bandgap voltage reference
2. Temperature sensor
3. Thermostat comparators

The DS56 incorporates an internal temperature sensor with a typical transfer function of (in mV with T expressed in °C):

$$V_{\text{TEMP}}(T) = 6.2 T + 395$$

The voltage associated with this transfer function is output on the  $V_{\text{TEMP}}$  pin, which has a typical output impedance of 1.5 k $\Omega$ .

The DS56 has two independent temperature comparators, each with its own input (or trip point) and output. The comparison voltage (the  $V_{\text{TEMP}}$  transfer function) is the same for both comparators. Additionally, the hysteresis for both comparators is typically 5°C (31.0 mV).

The DS56 bandgap voltage reference is available on pin 1 to allow for a designer to set the trip point(s) by resistively dividing the reference voltage. One possible scenario is illustrated in Figure 1. For optimum performance, the VREF pin should be connected to a 50  $\mu$ A load.

The comparator outputs are taken off-chip via open-drain FETs, thus requiring external pullups. The thermostat transfer function is illustrated in Figure 2.

The supply range of the DS56 is 2.7V to 5.5V, allowing for applications ranging from industrial control to battery-powered portable equipment.

## THERMOSTAT OUTPUT TRANSFER FUNCTION Figure 2

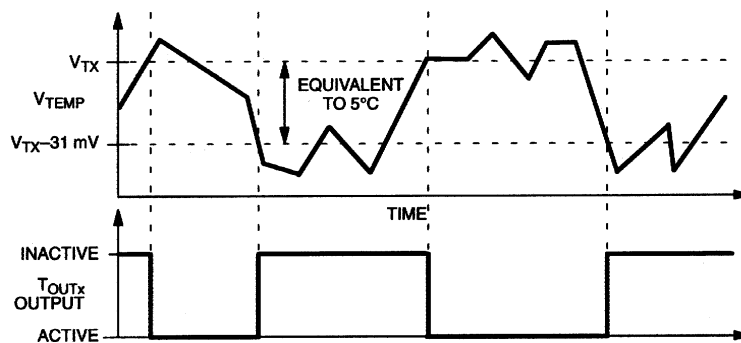

**ABSOLUTE MAXIMUM RATINGS\***

Voltage on $V_{DD}$	(GND-0.3V) to +7.0V
Input Current at any pin	5.0 mA
Package Input Current	20 mA
Operating Temperature	-40°C to +125°C
Storage Temperature	-55°C to 150°C
ESD Susceptibility (Human Body Model)	1kV
Soldering Temperature (Note 2)	215°C for 60 seconds (Vapor Phase) 220°C for 15 seconds (IR)

\* This is a stress rating only and functional operation of the device at these or any other conditions above those indicated in the operation sections of this specification is not implied. Exposure to absolute maximum rating conditions for extended periods of time may affect reliability.

The Dallas Semiconductor DS56 is built to the highest quality standards and manufactured for long-term reliability. All Dallas Semiconductor devices are made using the same quality materials and manufacturing methods. However, the DS56 is not exposed to environmental stresses, such as burn-in, that some industrial applications require. For specific reliability information on this product, please contact the factory in Dallas at (972) 371-4448.

**RECOMMENDED DC OPERATING CONDITIONS:**(-40°C to +125°C;  $2.7V \leq V_{DD} \leq 5.5V$ )

PARAMETER	SYMBOL	CONDITION	MIN	TYP	MAX	UNITS	NOTES
Supply Voltage	$V_{DD}$		2.7		5.5	V	1

**DC ELECTRICAL CHARACTERISTICS:****Power Supply (Note 3)**(-40°C to +125°C;  $2.7V \leq V_{DD} \leq 5.5V$ )

PARAMETER	SYMBOL	CONDITION	MIN	TYP	MAX	UNITS	NOTES
Supply Current	$I_{DD}$				225	$\mu A$	

**DC ELECTRICAL CHARACTERISTICS:****Temperature Sensor (Note 3)**(-40°C to +125°C;  $2.7V \leq V_{DD} \leq 5.5V$ )

PARAMETER	SYMBOL	CONDITION	MIN	TYP	MAX	UNITS	NOTES
Trip Point Accuracy	$TP_{ERR}$	$-40^{\circ}C \leq T_A \leq 125^{\circ}C$			$\pm 3$	$^{\circ}C$	4
		$0^{\circ}C \leq T_A \leq 85^{\circ}C$			$\pm 2$		
$V_{TEMP}$ Accuracy	$T_{ERR}$	$-40^{\circ}C \leq T_A \leq 125^{\circ}C$			$\pm 3$	$^{\circ}C$	5
		$0^{\circ}C \leq T_A \leq 85^{\circ}C$			$\pm 2$		
$V_{TEMP}$ DC Offset		$T=0^{\circ}C$		395		mV	
Sensor Gain	? V/? T			6.25		mV/ $^{\circ}C$	
Trip Point Hysteresis	$TP_{HYST}$		3.0	5.0	7.0	$^{\circ}C$	
Power Supply Regulation		$2.7V \leq V_{DD} \leq 3.3V$			$\pm 2.3$	mV	
		$3.0V \leq V_{DD} \leq 5.5V$			$\pm 0.3$	mV/V	
$V_{TEMP}$ Output Impedance					1500	$\Omega$	

**DC ELECTRICAL CHARACTERISTICS:****Bandgap Voltage Reference  $V_{REF}$**  (-40°C to +125°C; 2.7V ≤  $V_{DD}$  ≤ 5.5V)

PARAMETER	SYMBOL	CONDITION	MIN	TYP	MAX	UNITS	NOTES
$V_{REF}$ Output	$V_{REF}$		1.238	1.25	1.263	V	
Power Supply Regulation	? $V_{REF}/$	2.7V ≤ $V_{DD}$ ≤ 3.3V			±1.45	mV	
	? $V_{DD}$	3.0V ≤ $V_{DD}$ ≤ 5.5V			±0.2	mV/V	
Load Regulation	? $V_{REF}/$ ? $I_L$	+3.0μA ≤ $I_L$ ≤ +50μA			0.15	mV/μA	

**DC ELECTRICAL CHARACTERISTICS:****Trip Point Inputs  $V_{T1}/V_{T2}$**  (-40°C to +125°C; 2.7V ≤  $V_{DD}$  ≤ 5.5V)

PARAMETER	SYMBOL	CONDITION	MIN	TYP	MAX	UNITS	NOTES
Input Bias Current	$I_{BIAS}$				300	nA	
Input Range	$V_{TIN}$		0		( $V_{DD}$ -1.0)	V	

**DC ELECTRICAL CHARACTERISTICS:****Thermostat Outputs  $T_{OUT1}/T_{OUT2}$**  (-40°C to +125°C; 2.7V ≤  $V_{DD}$  ≤ 5.5V)

PARAMETER	SYMBOL	CONDITION	MIN	TYP	MAX	UNITS	NOTES
Logic 1 Output Leakage Current	$I_{OUT1}$	$V_{DD} = 5.0V$			1.0	μA	
LOGICAL 0 Output Voltage	$V_{OUT0}$	$I_{OUT} = +50 \mu A$			0.4	V	

**NOTES:**

- All voltages are referenced to ground, unless otherwise specified.
- Solder according to IPC standards.
- Specified for  $V_{TEMP}$  sourcing 1.0 μA (max) and  $V_{REF}$  load current = 50 μA.
- Includes error associated with internal temperature sensor, bandgap voltage  $V_{REF}$ , and comparator offset. External resistance tolerance and temperature coefficient not included in this spec.
- Thermometer error (expressed in °C) is the difference between  $[V_O(T) - 395]/6.20$  and the DS56 case temperature at  $V_{DD} = 3.0V$ , thus taking into account sensor error, DC offset error, sensor amplifier gain variations, and amplifier nonlinearity.

**TYPICAL DS56 THERMOMETER ERROR** Figure 3**TBD****TYPICAL DS56  $V_{TEMP}$  TRANSFER FUNCTION** Figure 4**TBD**

## DS56 PHYSICAL DIMENSIONS

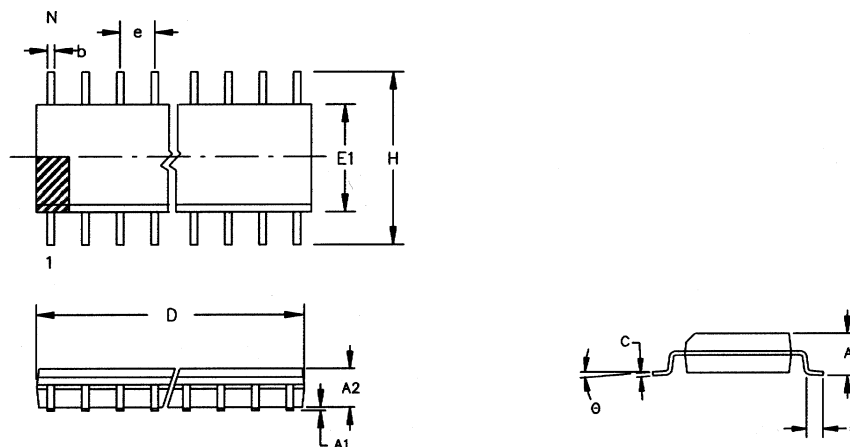

### 8-, 14-, AND 16-PIN SOIC (.150" BODY WIDTH)



PKG	8-PIN		14-PIN		16-PIN	
DIM	MIN	MAX	MIN	MAX	MIN	MAX
A IN.	0.053	0.069	0.053	0.069	0.053	0.069
MM	1.35	1.75	1.35	1.75	1.35	1.75
A1 IN.	0.004	0.010	0.004	0.010	0.004	0.010
MM	0.10	0.25	0.10	0.25	0.10	0.25
A2 IN.	0.048	0.062	0.048	0.062	0.048	0.062
MM	1.24	1.57	1.24	1.57	1.24	1.57
b IN.	0.012	0.020	0.012	0.020	0.012	0.020
MM	0.030	0.50	0.30	0.50	0.30	0.50
C IN.	0.007	0.011	0.007	0.011	0.007	0.011
MM	0.17	0.28	0.17	0.28	0.17	0.28
D IN.	0.188	0.196	0.337	0.344	0.386	0.393
MM	4.78	4.98	8.55	8.74	9.80	9.98
e IN.	0.050 BSC		0.050 BSC		0.050 BSC	
MM	1.27 BSC		1.27 BSC		1.27 BSC	
E1 IN.	0.150	0.158	0.150	0.158	0.150	0.158
MM	3.81	4.01	3.81	4.01	3.81	4.01
H IN.	0.230	0.244	0.230	0.244	0.230	0.244
MM	5.84	6.20	5.84	6.20	5.84	6.20
L IN.	0.016	0.050	0.016	0.050	0.016	0.050
MM	0.40	0.89	0.40	0.89	0.40	0.89
Q	0°	8°	0°	8°	0°	8°

## Looking for pricing, stock, or lifecycle information?

Click below to explore more details on WIN SOURCE:

-  [View DS56U on WIN SOURCE](#)
-  [Maxim Integrated Information](#)

## Optimize Your Supply Chain with WIN SOURCE Solutions

-  Global Sourcing Solution
-  Obsolete Management
-  Cost Control Management
-  Shortage Management
-  Alternative Solution
-  Excess Inventory Management