



# THE DATASHEET OF NTE5502





ELECTRONICS, INC.  
 44 FARRAND STREET  
 BLOOMFIELD, NJ 07003  
 (973) 748-5089  
<http://www.nteinc.com>

## NTE5500 thru NTE5509 Silicon Controlled Rectifier (SCR) 16 Amp, TO48

**Description:**

The NTE5500 thru NTE5509 series of industrial-type silicon controlled rectifiers (SCR) are available in a TO48 style package with a current handling capability to 25 Amps at junction temperatures to +125°C.

**Absolute Maximum Ratings:** ( $T_J = +125^\circ\text{C}$  unless otherwise specified)

Peak Forward Blocking Voltage,  $V_{DRM}$

NTE5500	25V
NTE5501	50V
NTE5502	100V
NTE5503	150V
NTE5504	200V
NTE5505	250V
NTE5506	300V
NTE5507	400V
NTE5508	500V
NTE5509	600V

Peak Reverse Blocking Voltage (Note1, Note2),  $V_{RSM(rep)}$

NTE5500	25V
NTE5501	50V
NTE5502	100V
NTE5503	150V
NTE5504	200V
NTE5505	250V
NTE5506	300V
NTE5507	400V
NTE5508	500V
NTE5509	600V

Peak Reverse Blocking Voltage (Transient, Non-Recurrent,  $t = 5\text{ms Max}$ , Note2),  $V_{RSM(non-rep)}$

NTE5500	35V
NTE5501	75V
NTE5502	150V
NTE5503	225V
NTE5504	300V
NTE5505	350V
NTE5506	400V
NTE5507	500V
NTE5508	600V
NTE5509	700V

Forward Current RMS (All Conduction Angles),  $I_T$  . . . . . 25A

Peak Forward Surge Current (One Cycle, 60Hz,  $T_J = -65^\circ$  to  $+125^\circ\text{C}$ ),  $I_{TSM}$  . . . . . 200A

Circuit Fusing Considerations ( $T_J = -65^\circ$  to  $+125^\circ\text{C}$ ,  $t \leq 8.3\text{ms}$ ),  $I^2t$  . . . . . 165A<sup>2</sup>s

Note 1.  $V_{RSM}$  can be applied on a continuous DC basis without incurring change.

Note 2.  $V_{RSM(rep)}$  ratings apply for zero or negative gate voltage.

**Absolute Maximum Ratings (Cont'd):** ( $T_J = +125^\circ\text{C}$  unless otherwise specified)

Peak Gate Power – Forward, $P_{GM}$ .....	5W
Average Gate Power – Forward, $P_{G(AV)}$ .....	500mW
Peak Gate Current – Forward, $I_{GM}$ .....	2A
Peak Gate Voltage – Forward, $V_{GFM}$ .....	10V
Peak Gate Voltage – Reverse, $V_{GRM}$ .....	5V
Operating Junction Temperature Range, $T_J$ .....	$-65^\circ$ to $+125^\circ\text{C}$
Storage Temperature Range, $T_{stg}$ .....	$-65^\circ$ to $+150^\circ\text{C}$
Stud Torque .....	30 in. lb. (3.33 m•N)

**Electrical Characteristics:** ( $T_C = +25^\circ\text{C}$  unless otherwise specified)

Parameter	Symbol	Test Conditions	Min	Typ	Max	Unit
Peak Forward or Reverse Blocking Current NTE5500 thru NTE5506	$I_{DRM}, I_{RRM}$	$T_J = +125^\circ\text{C}$	-	-	10	mA
NTE5507			-	-	8	mA
NTE5508			-	-	6	mA
NTE5509			-	-	4	mA
Gate Triggs Current (Continuous DC)	$I_{GT}$	Anode Voltage = 7V, $R_L = 50\Omega$	-	10	25	mA
Gate Trigger Voltage (Continuous DC)	$V_{GT}$	Anode Voltage = 7V, $R_L = 50\Omega$	0.25	-	3.0	V
Holding Current	$I_{HOLD}$	Anode Voltage = 7V, Gate Open	-	20	-	mA
Forward ON Voltage	$V_{TM}$	$I_T = 20\text{A}$	-	1.1	1.5	V
Turn-On Time	$t_{gt}$	$I_T = 10\text{A}, I_G = 100\text{mA}$	-	1.0	-	$\mu\text{s}$
Turn-Off Time	$t_q$	$T_J = +125^\circ\text{C}, I_T = 10\text{A}, I_R = 10\text{A},$ $dv/dt = 30\text{V}/\mu\text{s}$ Min, $V_{DRM} = \text{Rated Voltage}$	-	30	-	$\mu\text{s}$
Forward Voltage Application Rate	$dv/dt$	$T_J = +125^\circ\text{C}, \text{Gate Open}$	-	30	-	$\text{V}/\mu\text{s}$
Thermal Resistance, Junction to Case	$R_{\theta JC}$		-	1.0	2.0	$^\circ\text{C}/\text{W}$

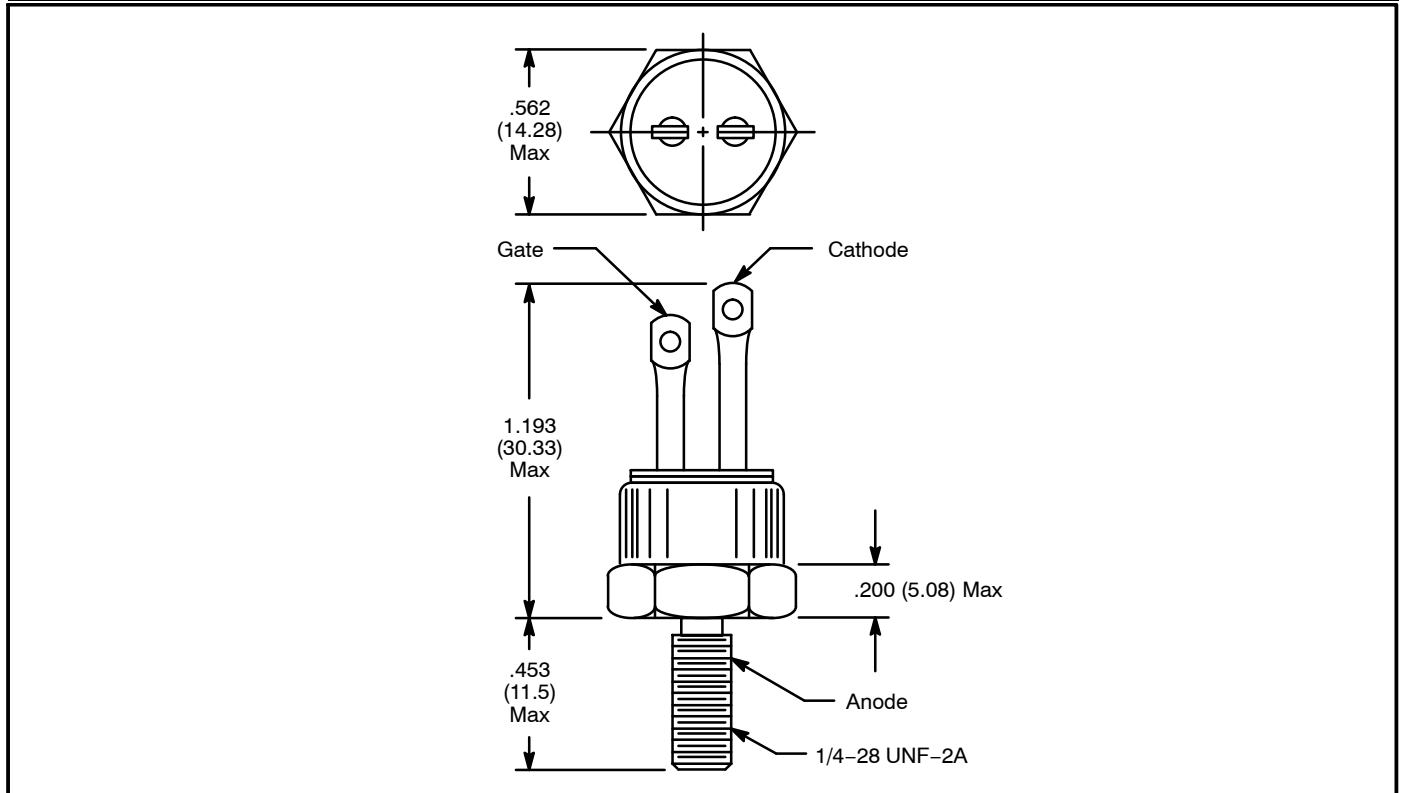

## Looking for pricing, stock, or lifecycle information?

Click below to explore more details on WIN SOURCE:

 [View NTE5502 on WIN SOURCE](#)

 [NTE Information](#)

## Optimize Your Supply Chain with WIN SOURCE Solutions

-  Global Sourcing Solution
-  Obsolete Management
-  Cost Control Management
-  Shortage Management
-  Alternative Solution
-  Excess Inventory Management