



**THE DATASHEET OF  
MPCC-2-16-2-L-64-118.0-S**



**-RA APPLICATION**

DO NOT  
SCALE FROM  
THIS PRINT

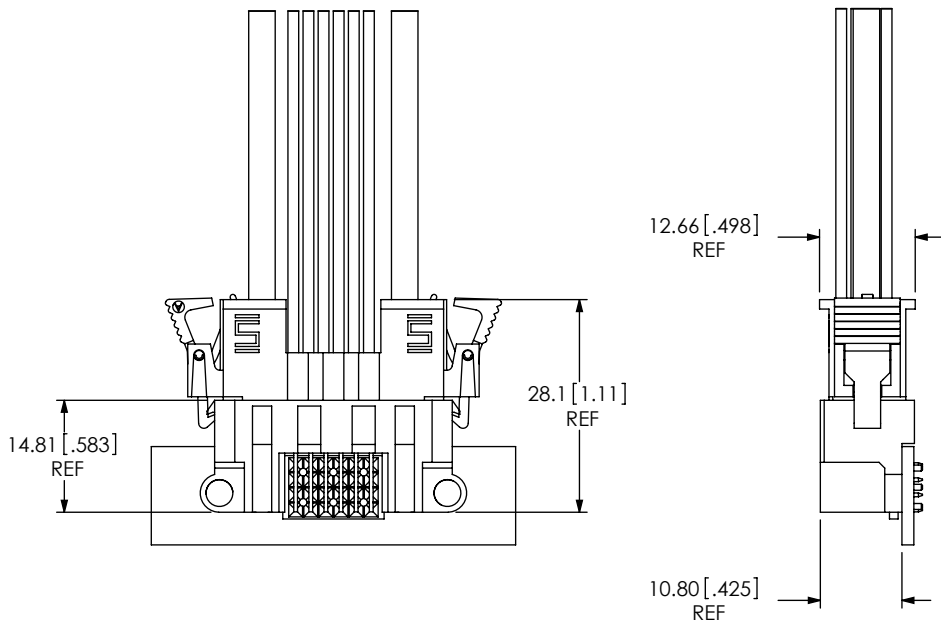
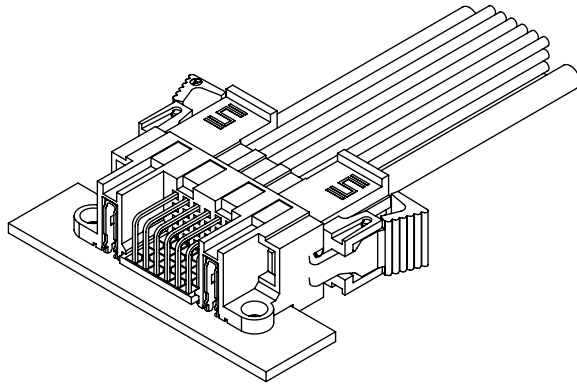

**-V APPLICATION**

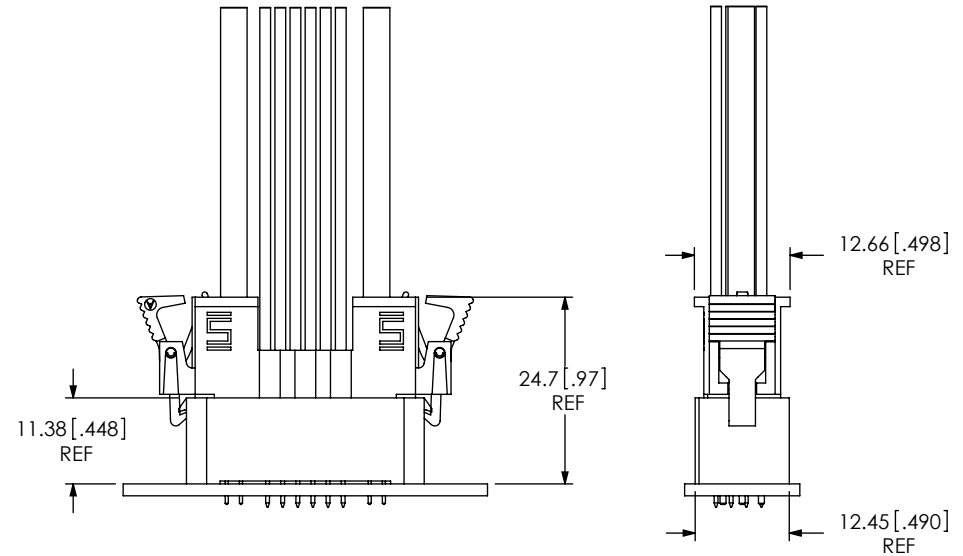
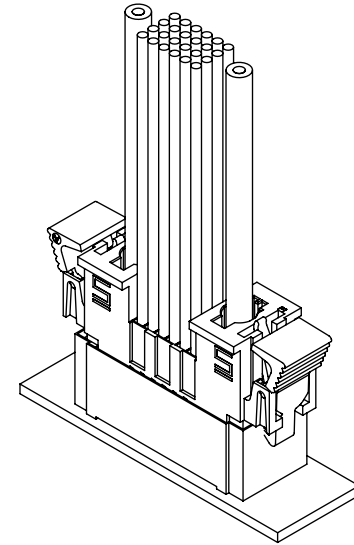

UNLESS OTHERWISE SPECIFIED,  
DIMENSIONS ARE IN MM[IN].  
TOLERANCES ARE:  
DECIMALS ANGLES  
X.X: ±0.3 [.01] 2°  
X.XX: ±0.13 [.005]  
X.XXX: ±0.051 [.0020]

**PROPRIETARY NOTE**  
THIS DOCUMENT CONTAINS INFORMATION  
CONFIDENTIAL AND PROPRIETARY TO  
SAMTEC, INC. AND SHALL NOT BE REPRODUCED  
OR TRANSFERRED TO OTHER DOCUMENTS OR  
DISCLOSED TO OTHERS OR USED FOR ANY  
PURPOSE OTHER THAN THAT WHICH IT WAS  
OBTAINED WITHOUT THE EXPRESSED WRITTEN  
CONSENT OF SAMTEC, INC.





520 PARK EAST BLVD., NEW ALBANY, IN 47150  
PHONE: 812-944-6733 FAX: 812-948-5047  
e-Mail: info@SAMTEC.com code 53322

DO NOT SCALE DRAWING SHEET SCALE: 1:1

DESCRIPTION:	MINI POWER COMBO CABLE
DWG. NO.	MPCC-APPLICATION
BY:	D.SCHMELZ 06/24/2010 SHEET 1 OF 1

## Looking for pricing, stock, or lifecycle information?

Click below to explore more details on WIN SOURCE:

-  [View MPCC-2-16-2-L-64-118.0-S on WIN SOURCE](#)
-  [Samtec Inc. Information](#)

## Optimize Your Supply Chain with WIN SOURCE Solutions

-  Global Sourcing Solution
-  Obsolete Management
-  Cost Control Management
-  Shortage Management
-  Alternative Solution
-  Excess Inventory Management