



THE DATASHEET OF DLPLCR4500EVM



TI DLP® LightCrafter™ 4500 Evaluation Module

User's Guide



Literature Number: DLPU011F
July 2013–Revised July 2017

Preface	6
1 DLP LightCrafter 4500 Module Overview	8
1.1 Welcome	8
1.2 What is in the DLP LightCrafter 4500 EVM?	8
1.2.1 Light Engine	9
1.2.2 Driver Board	12
1.2.3 Embedded Processor Interface	13
1.3 Other Items Needed for Operation	13
1.4 DLP LightCrafter 4500 Connections	14
1.5 DLP LightCrafter 4500 Jumpers	16
1.6 Dimensions	18
2 Quick Start	20
2.1 Power-up the DLP LightCrafter 4500	20
3 Operating the DLP LightCrafter 4500	21
3.1 DLP LightCrafter 4500 Software	21
3.2 PC Software	21
3.2.1 System Status	22
3.2.2 Operating Mode	23
3.2.3 Image Orientation	24
3.2.4 LED Current Settings	25
3.2.5 Video Mode	26
3.3 Pattern Sequence Mode	27
3.3.1 Sequence Settings	27
3.3.2 Sequence Settings [Variable Exposure]	32
3.3.3 Image Load Timing	33
3.3.4 Trigger Controls	34
3.3.5 LED Delay Control	36
3.4 Firmware Upgrade	37
3.5 Storing Images in Flash Memory	38
3.6 Peripheral Control	41
4 Pattern Sequences	42
4.1 Pattern Sequence Background	42
5 Saving Solutions	46
5.1 Applying Solutions	46
5.2 Changing Default Solutions	46
5.3 Modifying .ini Files	47
5.3.1 Available Parameters	47
5.3.2 Save Solution Button	49
5.3.3 Manual Editing	49
5.3.4 LUT Entry Helper Tool	49
6 PandaBoard Interface	51
6.1 PandaBoard 4500	51
6.1.1 DLP LightCrafter 4500 to PandaBoard Interface	52
6.1.2 PandaBoard Software	56

7	Connectors	58
7.1	Input Trigger Connectors	58
7.2	Output Trigger Connectors	58
7.3	DLPC350 UART	59
7.4	DLPC350 I2C0	59
7.5	DLPC350 I2C1	59
7.6	Fan	60
7.7	Red LED	60
7.8	Green LED	60
7.9	Blue LED	61
7.10	FPD-Link	61
7.11	JTAG Boundary Scan	62
7.12	Power	62
A	Safety	63
B	Power Supply Requirements	64
B.1	External Power Supply Requirements	64
	Revision History	65

List of Figures

1.	DLP LightCrafter 4500 Evaluation Module (EVM)	6
1-1.	DLP LightCrafter 4500 Block Diagram	9
1-2.	iView Light Engine	10
1-3.	0.45-Inch DMD Diamond Pixel Geometry	11
1-4.	0.45-Inch DMD Diamond Pixel Array Configuration	11
1-5.	Diamond Pixel for Vertical, Horizontal, and Diagonal Lines	11
1-6.	DLP LightCrafter 4500 Driver Board Block Diagram	12
1-7.	DLP LightCrafter 4500 Connectors (Top View)	15
1-8.	DLP LightCrafter 4500 Connectors (Back-Side View).....	15
1-9.	DLP LightCrafter 4500 Jumper Locations.....	16
1-10.	DLP LightCrafter 4500 J10 and J12 Voltage Jumpers	17
1-11.	DLP LightCrafter 4500 J13 and J15 Voltage Jumpers	17
1-12.	DLP LightCrafter 4500 Dimensions	19
3-1.	DLP LightCrafter 4500 GUI – Video Mode.....	22
2	Typical Red LED Current and Illuminance Based on PWM Values	25
3	Typical Green LED Current and Illuminance Based on PWM Values.....	25
4	Typical Blue LED Current and Illuminance Based on PWM Values.....	25
3-5.	DLP LightCrafter 4500 GUI – Pattern Sequence Mode	28
3-6.	Pattern Sequence Mode: Start, Pause, Stop	31
3-7.	Pattern Sequence Mode — Variable Exposure	33
3-8.	Image Load Timing.....	34
3-9.	Trigger Control Subtab	35
3-10.	VSYNC Pattern Trigger Mode	36
3-11.	External Pattern Trigger Mode	36
3-12.	LED Delay Control Subtab	37
3-13.	Firmware Upgrade Tab	38
3-14.	Create Images Tab.....	39
3-15.	Firmware Builder	40
3-16.	Peripheral Control Tab.....	41
4-1.	Relationship Between Bit-Planes and 24-bit RGB Images	42
4-2.	Bit Partition	42
4-3.	DLPC350 Internal Memory Buffer	43
4-4.	Frame Delay Between Parallel Interface Input and Projection Output	44
4-5.	Image Load Time and Pattern Sequence Timing	44
6-1.	DLP LightCrafter 4500 With PandaBoard 4500	52
6-2.	Block Diagram of the PandaBoard Interface	53

List of Tables

1-1.	DLP LightCrafter 4500 Light Engine Specifications	10
4-1.	Allowable Pattern Combinations	45
5-1.	List of Available Parameters when Saving Solutions	47
5-2.	Image LUT Entries Example	50
6-1.	J1 PandaBoard 4500 to DLP LightCrafter 4500 Interface	53
6-2.	J3 PandaBoard 4500 to DLP LightCrafter 4500 Interface	54
6-3.	J4 PandaBoard 4500 to DLP LightCrafter 4500 Interface	55
6-4.	J6 PandaBoard 4500 to DLP LightCrafter 4500 Interface	55
7-1.	Input Trigger Connector Pins	58
7-2.	Output Trigger Connector Pins	58
7-3.	UART Connector Pins	59
7-4.	I ² C0 Connector Pins	59
7-5.	I ² C1 Connector Pins	59
7-6.	Fan Connector Pins	60
7-7.	Red LED Connector Pins	60
7-8.	Green LED Connector Pins	61
7-9.	Blue LED Connector Pins	61
7-10.	FPD-Link Connector Pins	61
7-11.	JTAG Boundary Scan Connector Pins	62
7-12.	Power Connector Pins	62

Read This First

About This Guide

The DLP LightCrafter 4500 is a third-party implementation of the next generation DLP reference design to enable faster development cycles for applications requiring small form factor and intelligent pattern display.

This guide is an introductory document that provides an overview of the DLP LightCrafter 4500 system and its software. Other documents provide more in-depth information of the hardware and software features of the components of the DLP LightCrafter 4500.



Figure 1. DLP LightCrafter 4500 Evaluation Module (EVM)

Related Documentation From Texas Instruments

DLPC350 data sheet: *DLP Digital Controller for the DLP4500 DMD*, [DLPS029](#)

DLP4500 data sheet: *DLP 0.45 WXGA DMD*, [DLPS028](#)

DLPC350 and DLP4500 chipset manual: *DLP 0.45 WXGA Chipset Data Manual*, [DLPU009](#)

User's guide: *DLPC350 Programmer's Guide*, [DLPU010](#)

Application note: *Using DLP® LightCrafter 4500 Triggers to Synchronize Camera*, [DLPA036](#)

If User Needs Assistance

Refer to the [DLP and MEMS TI E2E Community support forums](#): [DLP LightCrafter 4500 Development Platform Forum](#)

Trademarks

LightCrafter is a trademark of Texas Instruments.

DLP is a registered trademark of Texas Instruments.

Bluetooth is a registered trademark of Bluetooth SIG, Inc.

Ubuntu is a registered trademark of Canonical Ltd.

Linux is a registered trademark of Linus Torvalds.

SVTronics is a registered trademark of SVTRONICS, INC.

Sullins Connector Solutions is a registered trademark of Sullins Connector Solutions, Inc.

DLP LightCrafter 4500 Module Overview

1.1 Welcome

The DLP LightCrafter 4500 evaluation module (EVM) allows evaluation of the DLP4500 chipset from TI.

This technology brings together a set of components providing an efficient and compelling system solution for:

- 3D scanning structured light applications:
 - 3D modeling and design
 - Fingerprint identification and face recognition
 - Machine vision and robotic factory automation
 - Industrial inspection
- Medical and life sciences:
 - Vascular imaging
 - Hyperspectral imaging
 - Dental impression scanners
 - Intraoral dental scanners
 - Orthopedics, prosthesis, CT, MRI, and X-ray marking
 - Retail cosmetics
- Small display projectors:
 - Embedded display
 - Interactive display
 - Information overlay
- Spectroscopy and chemical sensing
 - Material identification
 - Oil & Gas analysis
 - Water & air quality
 - Food & drug inspection
 - [TI DLP NIRscan EVM](#) uses the DLP4500NIR digital micromirror device (DMD) (similar to the DLP4500 in the DLP LightCrafter 4500 EVM and optimized for near-infrared light) in structured light mode to provide a high performance and cost-competitive spectroscopy solution

1.2 What is in the DLP LightCrafter 4500 EVM?

The DLP LightCrafter 4500 module consists of two subsystems:

- Light engine – includes the optics; red, green, and blue LEDs; and the 912 × 1140 diamond pixel 0.45-inch WXGA DMD, heat sinks, and fan. The light engine produces approximately 150 lumens at 15-W LED power consumption.
- Driver board – includes the LED driver circuits, DLPC350 DMD controller, power-management circuits, DVI-to-RGB conversion with the TFP401, and a 32-MB flash storage

[Figure 1-1](#) shows the major hardware components.

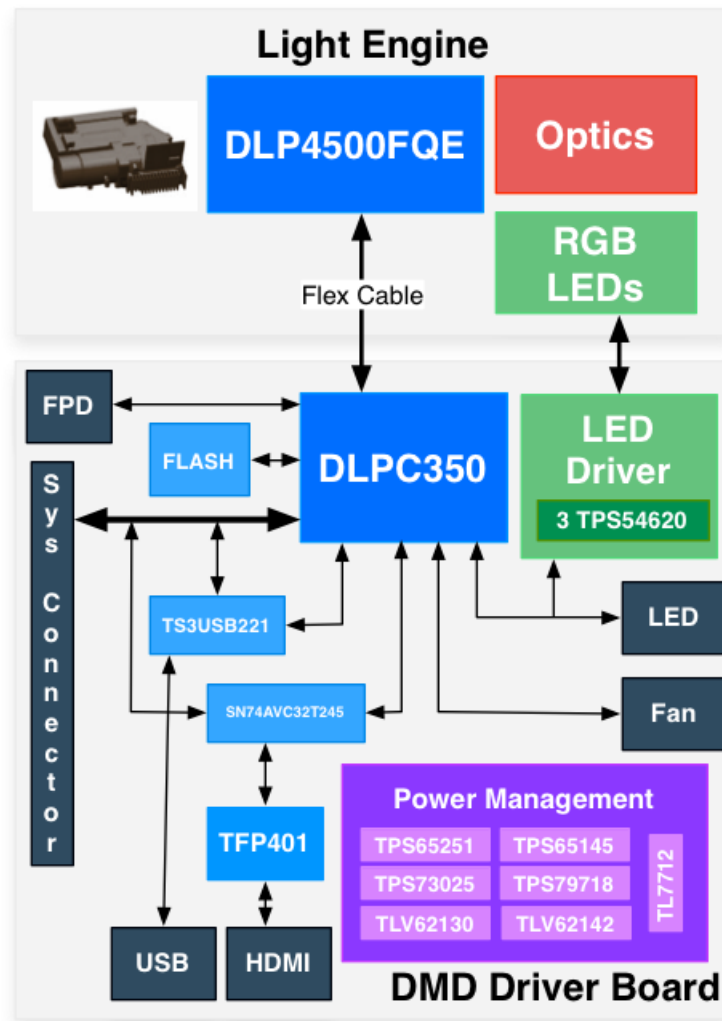

Figure 1-1. DLP LightCrafter 4500 Block Diagram

1.2.1 Light Engine

iView Limited developed the IPD 1231 light engine for the DLP LightCrafter 4500. As shown in Figure 1-2, the light engine includes:

- DLP4500FQE DMD
- DMD heat sink
- Red, green, and blue LEDs
- Focus control
- Projection lens

The iView Light Engine is mounted on top of a large thermal plate to cool the module. The DLP4500 DMD is mounted vertically between the DMD heat sink and the light engine. On the opposite side to the DMD, the red and green LEDs are mounted between a thermal plate and the light engine. The blue LED is mounted between a thermal plate and the light engine, next to the projection lens. An LED heat sink is mounted behind the red and green LED thermal plate and thermally connected to the blue LED thermal plate. A fan forces air across the LED heat sink to cool the LEDs.

The light engine, not including the LED heat sinks, has a length of 90.5 mm, width of 73.7 mm, and height of 23.6 mm.

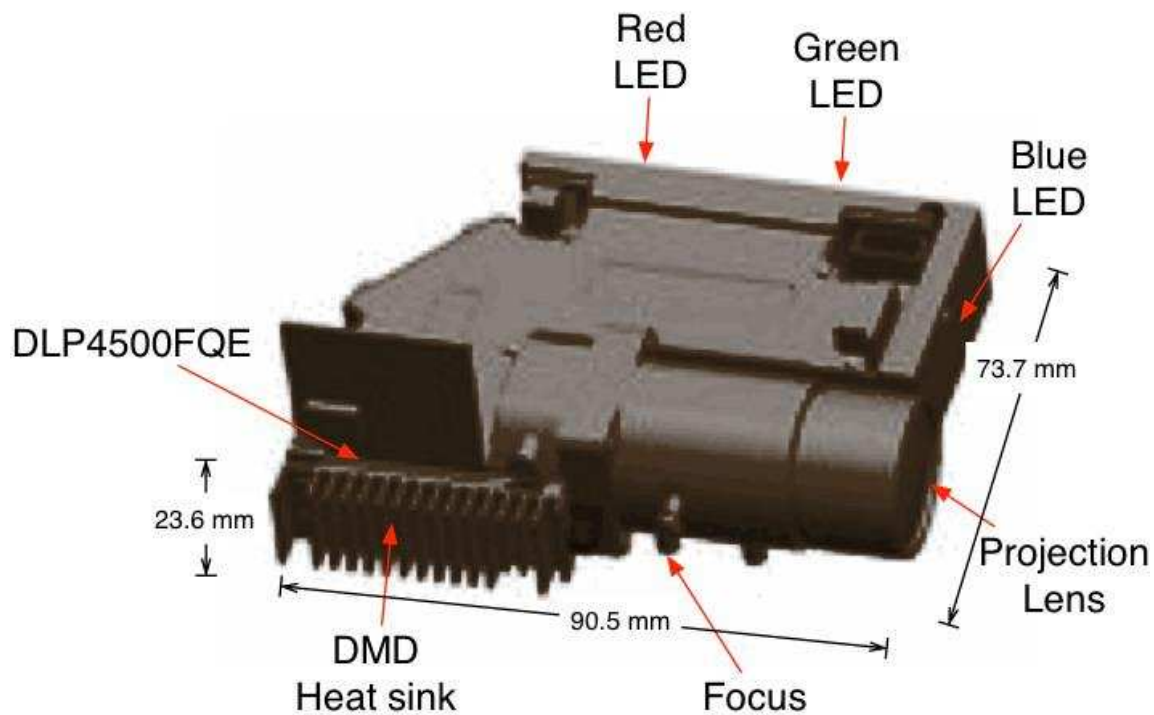

Figure 1-2. iView Light Engine

Table 1-1 lists the specifications of the light engine:

Table 1-1. DLP LightCrafter 4500 Light Engine Specifications

Parameter	MIN	TYP	MAX	UNIT
Brightness		150		lm
LED power consumption		15		W
Full-on full-off contrast		1000:1		
Uniformity	80	90		%
F-number		2.1		
Throw ratio		1.2		
Offset		100		%
Focus range	0.5	1	2	m
Image diagonal size	16.7	32.8	65	inch

The light engine includes the DLP4500 0.45-inch DMD with 1039680 mirrors, each 7.6 μm , arranged in 912 columns by 1140 rows with the diamond pixel array geometry and configuration (see [Figure 1-3](#) and [Figure 1-4](#)). Due to the diamond pixel configuration, the array produces smooth diagonal lines, with jagged vertical and horizontal lines, as shown in [Figure 1-5](#). Two options exist to produce the vertical and horizontal lines: use every row or column, or use every other row or column. When every row or column is used, a more thick line is projected. When every other row or column is used, a more faint line is projected.

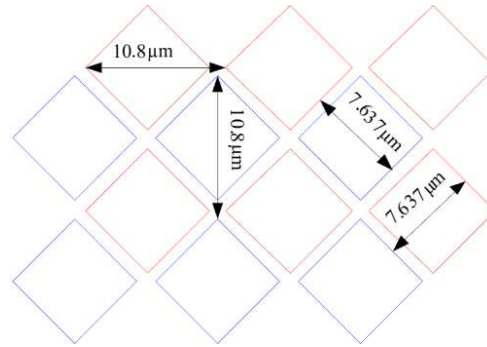

Figure 1-3. 0.45-Inch DMD Diamond Pixel Geometry

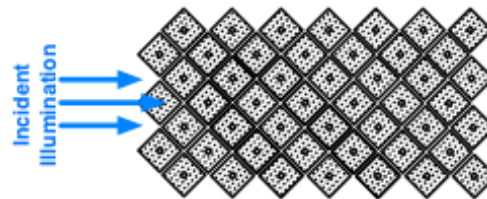

Figure 1-4. 0.45-Inch DMD Diamond Pixel Array Configuration

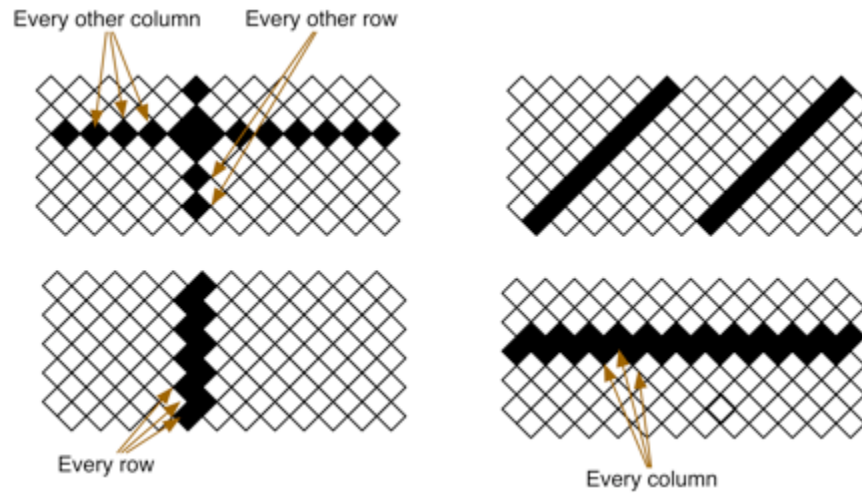

Figure 1-5. Diamond Pixel for Vertical, Horizontal, and Diagonal Lines

1.2.1.1 Light Engine Thermal Limits

The DLP LightCrafter 4500 is an actively cooled system with a thermal limit requiring that of all three simultaneous LED currents is less than 4.3 A.

CAUTION

Do not overheat the system by driving all LEDs at maximum power.

1.2.2 Driver Board

The DLP LightCrafter 4500 driver board contains the electronics to drive the DLP4500 DMD, LEDs of the light engine, and the LED cooling fan. The driver board offers several interface options for USB, I²C, trigger inputs and outputs, video input through mini-HDMI and FPD-link connector, and a system board interface. Figure 1-6 shows the driver board block diagram of the DLP LightCrafter 4500.

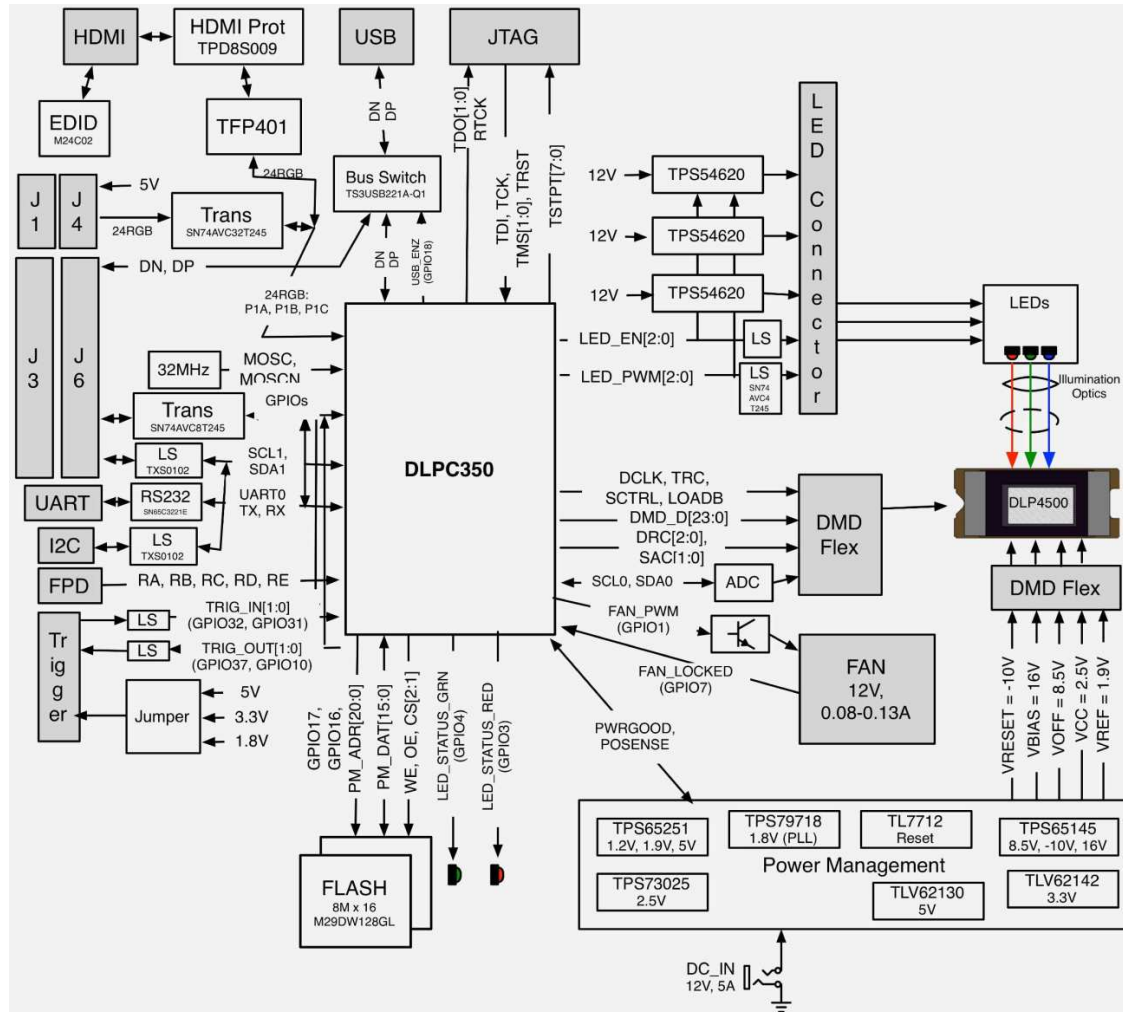

Figure 1-6. DLP LightCrafter 4500 Driver Board Block Diagram

The DLP LightCrafter 4500 driver board major components are:

- DLP4500: 0.45 inch-WXGA DMD
- DLPC350: DLP4500 controller
- 32-MB parallel flash contains DLPC350 firmware and 24-bit compressed images
- TPS54620: Synchronous step-down converter serving as an LED driver capable of driving up to 5 A per LED
- Power management:
 - TPS65251: Triple output buck switcher for DLPC350 1.2-V, 1.9-V supplies and 5-V board supply.
 - TPS65145: Triple output boost converter for DLP4500 8.5-, -10-, and 16-V supplies
 - TPS73025: Step-down converter for DLP4500 2.5-V supply
 - TLV62130: Step-down converter for 3.3-V supply
 - TLV62130: Step-down converter for 5-V system board supply
 - TPS79718: LDO for DLPC350 1.8-V analog supply

- TL7712: Programmable time delay for power-supply sequencing
- TFP401: Digital Receiver for DVI to 24-bit parallel RGB interface
- TS3USB2221A: ESD-protected high-speed USB multiplexer
- SN74AVC32T245: 32-bit dual supply bus transceiver for system board interface

1.2.3 Embedded Processor Interface

The DLP LightCrafter 4500 driver board allows the connection of a PandaBoard ES. See, [Chapter 6](#).

1.3 Other Items Needed for Operation

The DLP LightCrafter 4500 module is a flexible, ready-to-use EVM. However, the DLP LightCrafter 4500 EVM does not ship with cables, power supply, or additional hardware components. To use the EVM, the user needs the following:

- Power supply:
 - Nominal voltage: 12-V DC
 - Typical current: 6 A
 - Maximum current: 7 A
 - DC connector size:
 - Inner diameter: 2.5 mm
 - Outer diameter: 5.5 mm
 - Shaft: 9.5-mm female, center positive
 - Efficiency level: V
 - A recommended power supply is [Digi-Key part number 62-1186-ND](#) , or equivalent.
- USB cable: A to mini-B USB cable
- Optional: [PandaBoard 4500](#)

1.4 DLP LightCrafter 4500 Connections

Figure 1-7 and Figure 1-8 depict the switches and connectors with their respective locations. The following list corresponds to the callouts on these figures. The figure does not include cables, or a power supply.

1. Reset button
2. Power connector: Use a power supply with a 12-V DC output with current of 6 to 7-A rating and a plug of 2.5-mm inner diameter × 5.5-mm outer diameter and 9.5-mm female center positive shaft. The current output of the power supply determines how much current the LED driver can supply
3. External trigger output connector: Supports two trigger output signals, each with configurable voltage of 3.3 V and 1.8 V through jumpers, J13 and J15, respectively.
4. Mini-USB connector: use an A to mini-B USB cable to connect to a PC.
5. UART/RS232 mini-plug connector output: DLPC350 3.3-V UART output for error messages. Mini-plug tip is DLPC350 transmit (TX) and ring is DLPC350 receive (RX) signals. UART has the following serial configuration:
 - Bits per second: 115200
 - Data bits: 8
 - Parity: None
 - Stop bits: 1
 - Flow control: None
6. External trigger Input connector: Supports two trigger input signals, each with configurable voltage of 5 V, 3.3 V and 1.8 V through jumpers, J10 and J12
7. Stand-by switch: Places the DLP LightCrafter 4500 in standby mode, powering down the LED driver and the DLPC350
8. Flat panel display-link connector
9. Fan connector
10. Red LED supply connector (bottom of the board)
11. DLPC350 I2C1 bus
12. DLPC350 I2C0 bus
13. Green LED supply connector
14. Blue LED supply connector
15. External LED driver connector: Install a jumper in J30 to disable the DLP LightCrafter 4500 LED drivers and set jumper J28 for 3.3-V or 1.8-V supply. Then use this connector to control an external LED driver board to power the LEDs of the DLP LightCrafter 4500 light engine or external light engine.
16. System board connector: This interface routes USB, I²C, GPIO, and triggers from DLPC350 to a system board to control the DLP LightCrafter 4500.
17. Focus control (bottom of the board): Adjust focus from 0.5 m to infinity
18. JTAG connector for DLPC350
19. JTAG Boundary Scan for DLPC350 (bottom of the board)
20. DVI input through mini-HDMI connector (bottom of the board). This input supports resolutions of 1280 × 800, 1024 × 768, 1024 × 640, 912 × 1140, 800 × 600, 800 × 500, and 640 × 480 at up to 120 Hz. In Video Mode, the DLPC350 scales the input resolution to the native resolution of the DLP4500 DMD. In Pattern Sequence mode, this input supports 912 × 1140 resolution.

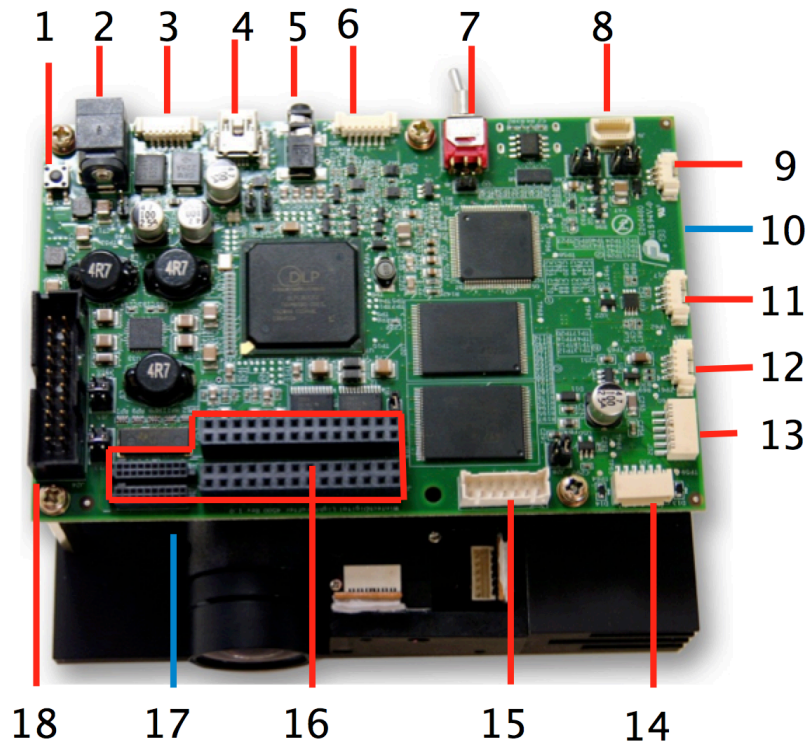

Figure 1-7. DLP LightCrafter 4500 Connectors (Top View)

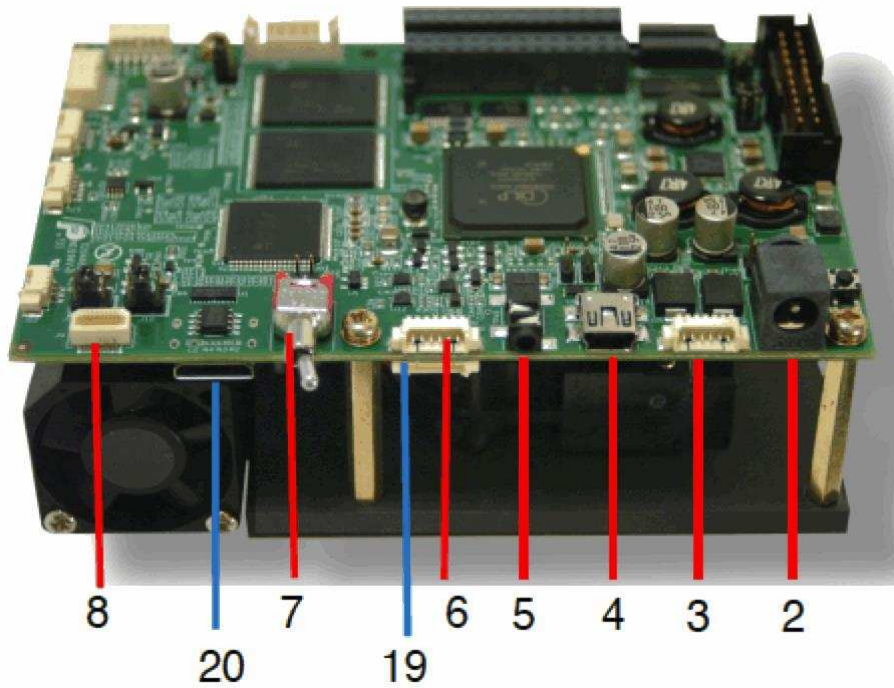

Figure 1-8. DLP LightCrafter 4500 Connectors (Back-Side View)

1.5 DLP LightCrafter 4500 Jumpers

The DLP LightCrafter 4500 has jumper options to disable the onboard LED driver, control voltages of the LED signals to an external board, and control the trigger input and output voltages. This section lists all the jumpers on the DLP LightCrafter 4500 driver board. [Figure 1-9](#) depicts the locations of these jumpers. These jumpers require a 2-mm jumper, like Sullins Connector Solutions® SPN02SYBN-RC, Digi-Key part number S3404-ND.

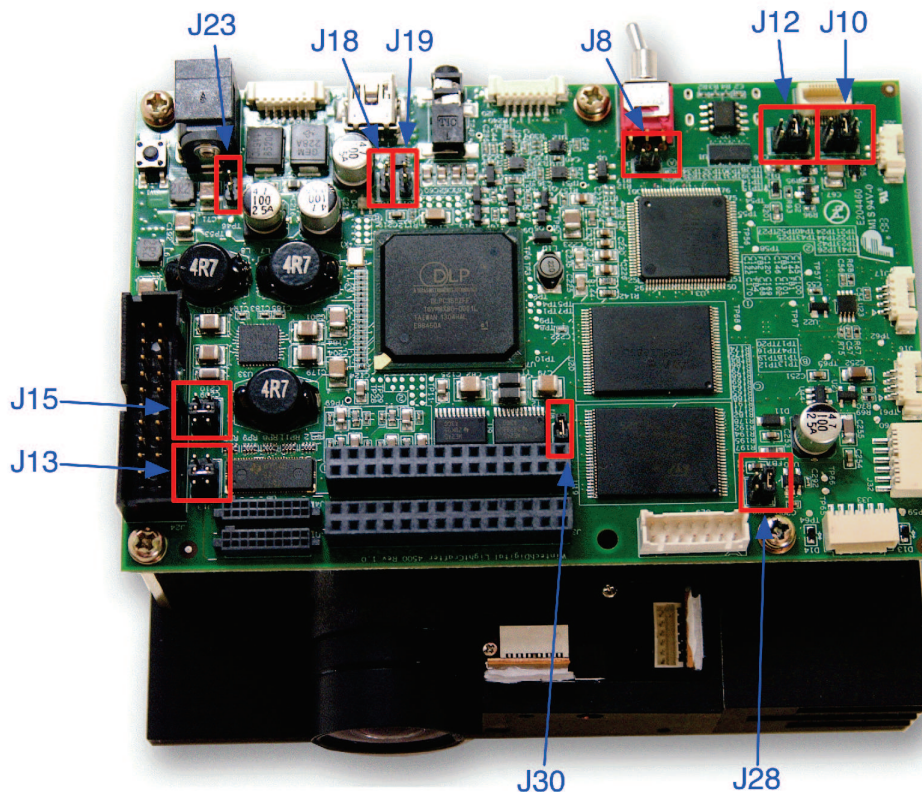

Figure 1-9. DLP LightCrafter 4500 Jumper Locations

- J8: EDID write protect disable jumper. Place this jumper to reprogram the EDID EEPROM (U2) using I²C commands through the mini-HDMI connector. Remove the jumper when programming of the EDID is complete. The EDID is programmed at the factory with resolutions of 1280 x 800 and 912 x 1140.
- J10: DLPC350 TRIG1_IN voltage selection. See to [Figure 1-10](#).
 - Jump across pins 3 to 4 for 3.3 V
 - Jump across pins 5 to 6 for 1.8 V
- J12: DLPC350 TRIG2_IN voltage selection. See to [Figure 1-10](#).
 - Jump across pins 3 to 4 for 3.3 V
 - Jump across pins 5 to 6 for 1.8 V

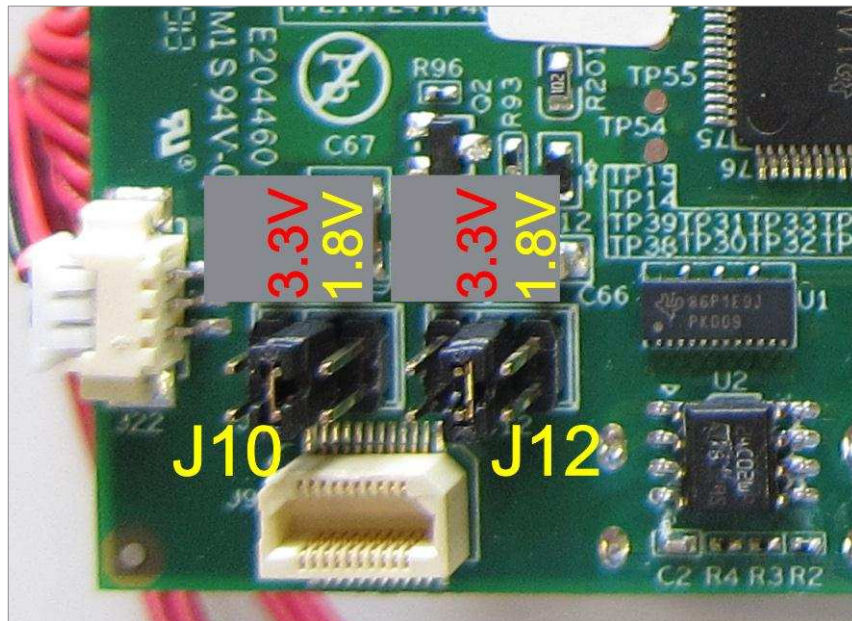

Figure 1-10. DLP LightCrafter 4500 J10 and J12 Voltage Jumpers

- J13: DLPC350 TRIG1_OUT voltage selection. See to [Figure 1-11](#).
 - Jump across pins 3 to 4 for 3.3 V
 - Jump across pins 5 to 6 for 1.8 V
- J15: DLPC350 TRIG2_OUT voltage selection. See to [Figure 1-11](#).
 - Jump across pins 3 to 4 for 3.3 V
 - Jump across pins 5 to 6 for 1.8 V

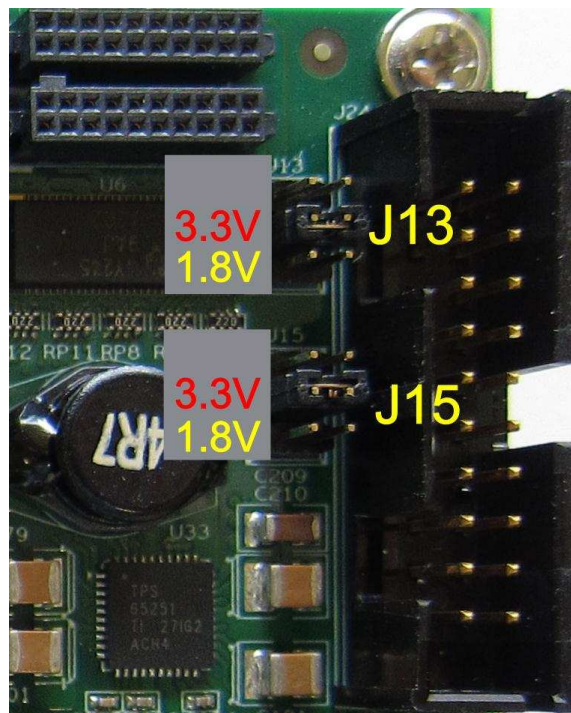

Figure 1-11. DLP LightCrafter 4500 J13 and J15 Voltage Jumpers

- J18: DLPC350 HOLD_IN_BOOT. Jump across this header to hold the DLPC350 in bootloader mode.

This action is needed only if the DLP LightCrafter 4500 firmware becomes corrupted and must be reprogrammed through the JTAG boundary scan or USB. The graphical user interface (GUI) firmware upgrade process places the DLPC350 in bootloader mode through software commands and does not need the jumper.

- J19: Device address select
 - Jump across header to set I²C address to 0x3A and USB device serial number to LCR2.
 - Do not populate jumper to set I²C address to 0x34 and USB device serial number to LCR2.
- J23: Hold in reset. Jump across header to drive and hold reset line low. Jumping across this header is equivalent to pressing and holding the reset switch.
- J28: DLPC350 LED signals voltage selection. This jumper must be populated when bypassing the onboard LED driver and using an external LED driver.
 - Jump across pins 1 to 2 to set the DLPC350 LED enables and PWM signals to 3.3 V.
 - Jump across pins 3 to 4 to set the DLPC350 LED enables and PWM signals to 1.8 V.
- J30: DLPC350 LED driver disable. This jumper must be populated when bypassing the onboard LED driver and using an external LED driver.
 - Jump across header to disable the onboard LED driver and turn off all LEDs, regardless of the DLP LightCrafter 4500 video mode.
 - Do not populate this header for normal operation using the onboard LED driver.

1.6 Dimensions

The DLP LightCrafter 4500 optical engine is mounted on top of a thermal plate to provide passive cooling to the module. A heat sink and fan provide active cooling to the LEDs. The DLP4500, 0.45-in. DMD, is vertically mounted at the end of the optical engine and attached with a flex cable to the driver board that lies on top of the light engine. The dimensions of the DLP LightCrafter 4500 are of 98 mm long, 121.6 mm wide, and 47.7 mm tall. [Figure 1-12](#) shows DLP LightCrafter 4500 dimensions.

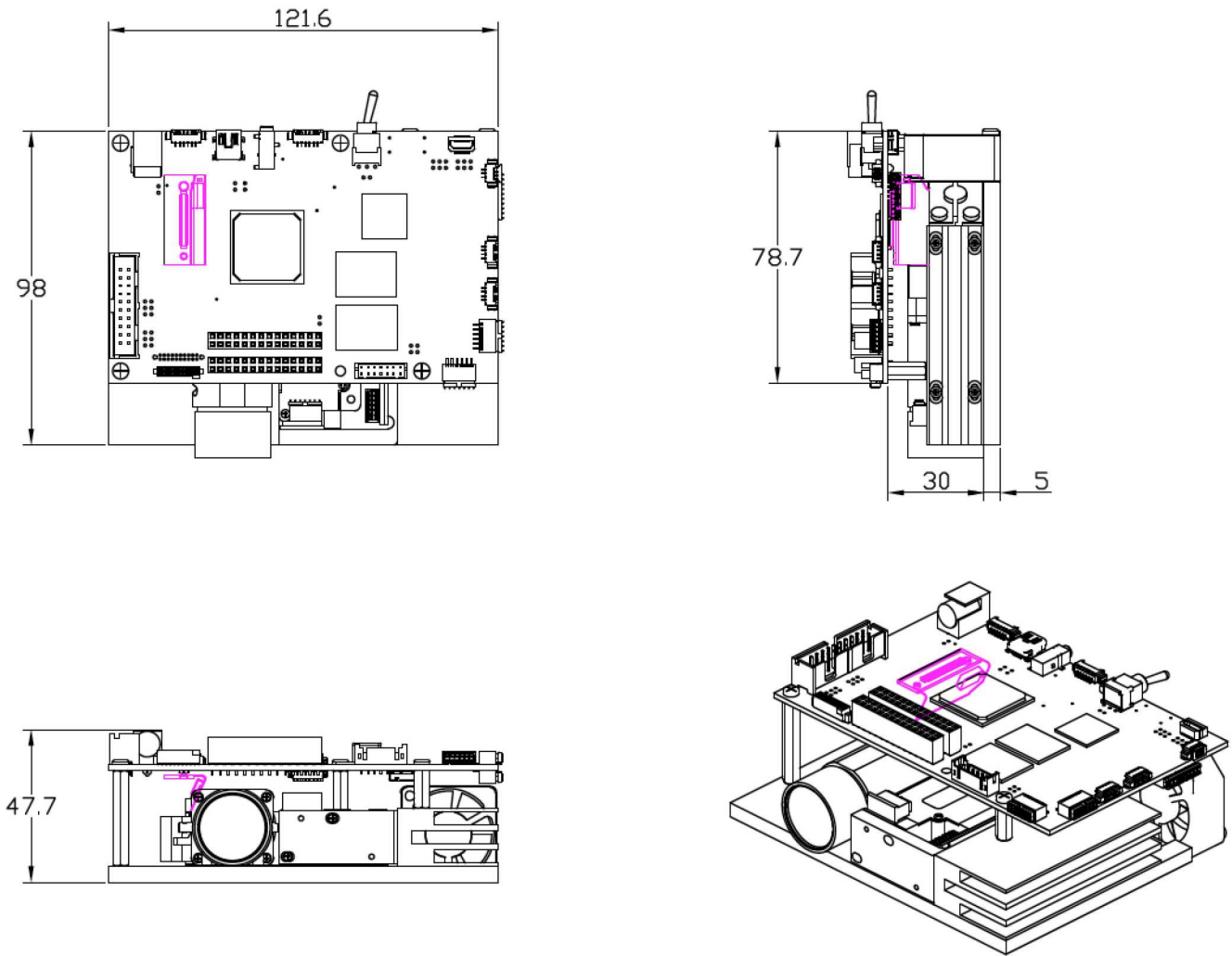

Figure 1-12. DLP LightCrafter 4500 Dimensions

Quick Start

This chapter details the steps to power up the DLP LightCrafter 4500 and connect to a PC.

2.1 Power-up the DLP LightCrafter 4500

The DLP LightCrafter 4500 is ready to use, out of the box. Steps 1 through 5 show how to power, display an image, and connect the device to a PC.

1. Connect a 12-V DC power supply to the power supply connector (connector 2 in [Figure 1-8](#)).
2. An LED on the bottom of the DLP LightCrafter 4500 board, next to the flex cable lights up green. The fan starts, stops, and then restarts while the DLPC350 is booting. After 5 to 10 seconds, the DLPC350 bootloads and displays a screen with the DLP logo and DLP LightCrafter 4500 logo. The D4 LED on top of the DLP LightCrafter 4500 board flashes on and off green. If the board shuts down after briefly turning on the display, the power supply current rating might be too low.
3. To display video, connect a DVI source to the mini-HDMI connector (connector 20 in [Figure 1-8](#)).
4. Control the DLP LightCrafter 4500 with the free GUI software (available to download from <http://www.ti.com/tool/dplcr4500evm>).
5. After installing the software on the computer, connect the PC to the DLP LightCrafter 4500 using a USB to mini-USB cable (connector 4 in [Figure 1-8](#)). The first time the cable is connected on a PC, the DLP LightCrafter 4500 emulates a USB composite device with human-interface device (HID) class. No drivers are required because these drivers are natively handled by all operating systems.

Operating the DLP LightCrafter 4500

This chapter introduces the PC software provided with the DLP LightCrafter 4500.

3.1 DLP LightCrafter 4500 Software

The DLP LightCrafter 4500 includes a QT-based GUI application to control the module through the USB interface. QT is a Nokia cross-platform application and user-interface framework with open source and commercial licenses. To install the QT GUI, just expand the LightCrafter4500_GUI.zip file into a directory and double-click on the executable file.

The DLP LightCrafter 4500 supports three main modes of operation:

- *Video mode* displays images from:
 - DVI input through the mini-HDMI connector
 - 24-bit RGB bitmaps stored in flash memory
 - 24, 20, 16, 10, and 8-bit RGB input through the system board connectors (J1, J3, J4, and J6)
 - Internal test patterns
 - 30-bit RGB through flat panel display (FPD) link
- *Pattern Sequence* mode displays images from:
 - 1-, 2-, 3-, 4-, 5-, 6-,7-, and 8-bit bitmap images stored in flash memory
 - 1-, 2-, 3-, 4-, 5-, 6-, 7-, and 8-bit bitmap images streamed through the DLPC350 24-bit RGB interface (mini-HDMI, FPD-link, or system board connectors)
 - The chosen pattern exposure and pattern period times apply to all patterns in the pattern sequence
- *Pattern Sequence [Variable Exposure]* mode displays images from the same sources as *Pattern Sequence* mode:
 - 1-, 2-, 3-, 4-, 5-, 6-,7-, and 8-bit bitmap images stored in flash memory
 - 1-, 2-, 3-, 4-, 5-, 6-, 7-, and 8-bit bitmap images streamed through the DLPC350 24-bit RGB interface (mini-HDMI, FPD-link, or system board connectors)
 - This mode allows for the pattern exposure time and pattern period to be set per pattern in the pattern sequence

3.2 PC Software

Upon execution of the LightCrafter4500.exe file, the window shown in [Figure 3-1](#) displays. The GUI window contains the following two sections:

- The top portion of the GUI window displays the *System Control* and controls the *Operating Mode*, *Image Orientation*, *LED Driver Control* settings, and *LED Selection*. There are also controls for saving and applying solutions.
- The bottom portion of the GUI window offers a set of tabs to further control the selected *Operating Mode*.

In any of the GUI sections, clicking a **Get** button reads the current settings of that particular subsection. Clicking the **Set** button programs the settings in the respective subsection. Some commands may require additional steps before the GUI display is updated.

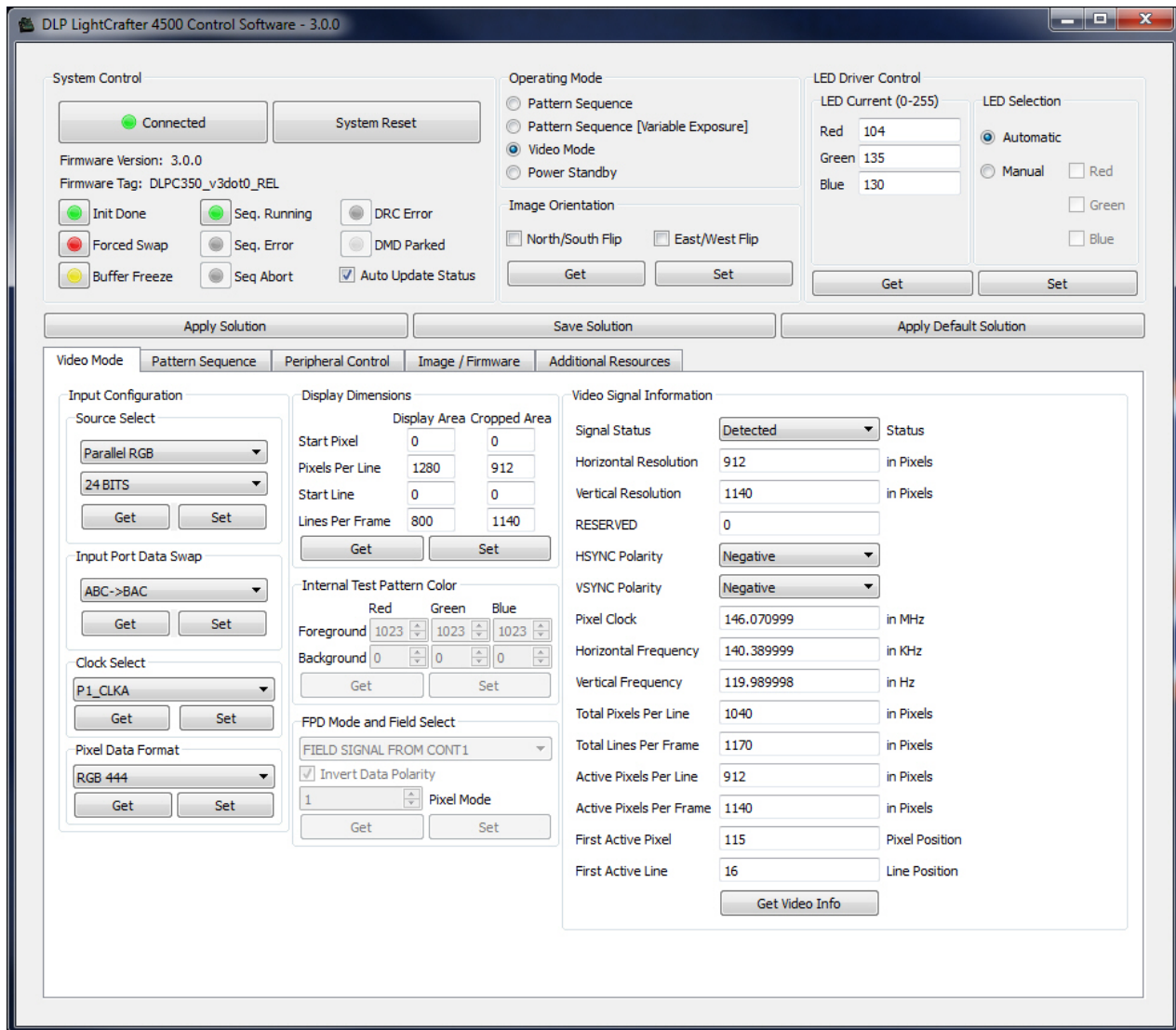

Figure 3-1. DLP LightCrafter 4500 GUI – Video Mode

The DLP LightCrafter 4500 GUI communicates with the DLPC350 using USB 1.1. The DLPC350 emulates as a USB device with HID support. The PC polls all the HID peripherals and once the PC detects the DLPC350, the **Connected** button changes to green. If the USB cable is disconnected, the color of the **Connected** button changes to red and the *Connected* text is grayed-out. Once the *System Status* shows **Connected**, the firmware version, firmware tag, hardware, and *System Status* indicators are displayed. There is no need to press the **Connected** button, because the HID peripheral is detected by the operating system after USB enumeration.

3.2.1 System Status

At the top-left portion of the GUI window, the hardware and *System Status* indicators report the following:

- *Init Done*: When highlighted green, it indicates the successful completion of the DLPC350 initialization. When highlighted grey, it indicates the DLPC350 had an error during initialization.
- *Sequencer Running*: When highlighted green, the DLPC350 sequencer is running as usual. When highlighted gray, the DLPC350 sequencer is stopped.
- *DRC Error*: DMD Reset Controller Error indicator. When highlighted grey, the DMD Reset Controller has not detected an error. When highlighted red, the DMD Reset Controller has found multiple overlapping bias or reset operations accessing the same DMD block of micromirrors.

- **Forced Swap:** When highlighted red, the DLPC350 sequencer detected a forced buffer swap error indicating that image data has been displayed from the wrong internal display buffer. When highlighted gray, no buffer swap error has occurred. This error can occur if the DLP LightCrafter 4500 is set to *Video Mode* and the vertical backporch timing is too small. The error can also occur if the DLP LightCrafter 4500 is set to *Pattern Sequence* mode with patterns input from the video port and pattern sequence timings do not match the video port VSYNC.
- **Sequencer Error:** When highlighted red, the DLPC350 sequencer has detected an error. When highlighted gray, the DLPC350 sequencer detected that no error occurred.
- **DMD Parked:** When highlighted yellow, the DMD micromirrors are parked in the position normal to the DMD plane. When highlighted gray, the DMD micromirrors are not parked.
- **Buffer Freeze:** When highlighted yellow, the frame buffer is frozen. When highlighted gray, the frame buffer is not frozen. This is cleared on the next buffer swap.
- **Sequencer Abort:** When highlighted red, the DLPC350 sequencer has detected an error condition that caused an abort. When highlighted gray, the DLPC350 sequencer detected that no error occurred.

These indicators are updated every 2 seconds, or when a command is issued to the DLPC350.

- **Auto Update Status.** When checked, all indicators will continue to update every two seconds. When unchecked, the indicators will stop updating and turn gray. While running in Pattern Sequence Mode, keeping the option unchecked prevents the GUI from interrupting the DLPC350 controller which will be processing critical functions related to pattern display.

3.2.2 Operating Mode

To the right of the *System Status*, the *Operating Mode* sets how the DLP LightCrafter 4500 operates:

- **Pattern Sequence mode:** The DLPC350 takes 1-, 2-, 3-, 4-, 5-, 6-, 7-, and 8-bit data from one of the following interfaces:
 - 24-bit RGB interface
 - FPD-link interface
 - Flash memory

The DLPC350 does not apply any video processing functions and provides a pixel accurate mode where every pixel maps to the native DMD resolution of 912 × 1140.

- **Pattern Sequence [Variable Exposure] mode:** The DLPC350 takes 1-, 2-, 3-, 4-, 5-, 6-, 7-, and 8-bit data from one of the following interfaces:
 - 24-bit RGB interface
 - FPD-link interface
 - Flash memory

This mode differs from Pattern Sequence mode in that the pattern exposure time and pattern period can be varied per pattern in the pattern sequence.

The DLPC350 does not apply any video processing functions and provides a pixel accurate mode where every pixel maps to the native DMD resolution of 912 × 1140.

- **Video Mode:** The DLPC350 takes 24, 20, 16, 10, and 8-bit data from one of the following interfaces:
 - 24-bit RGB interface
 - FPD-link interface
 - Internal test pattern generator
 - Flash memory

The DLPC350 then applies video processing functions, such as scaling, gamma correction, and color coordinate adjustments, and sends the processed image to the DMD.

- **Power Standby:** Places the DLPC350 in low-power state and powers down the DMD interface.

NOTE: If the DLP LightCrafter 4500 is disconnected from the USB and reconnected, the operating mode may not reflect the mode it was just working in. This can occur in pattern sequence modes when a pattern was not fully validated before being sent to the DLP LightCrafter 4500.

3.2.3 Image Orientation

Beneath *Operating Mode*, the *Image Orientation* controls the long and short axis flips to support front, rear, table, and ceiling mounted projection. The *Image Orientation* occurs on the next image or frame load in *Video mode*, and on the next download to the DLP LightCrafter 4500 in *Pattern Sequence mode*.

- *East/West Flip*: If checked, the image is flipped along the east and west axis of the projected image. Usual table front projection has this setting unchecked. Otherwise, the image is flipped horizontally.
- *North/South Flip*: If checked, the image is flipped along the north and south axis of the projected image. Usual table front projection has this setting unchecked. Otherwise, the image is flipped vertically.

3.2.4 LED Current Settings

On the top-right of the GUI window, the *LED Current* settings control the individual currents of the red, green, and blue LEDs. A setting of 255 corresponds to the maximum LED current. A setting of 0 corresponds to minimum LED current. The LED current is computed as follows:

$$\text{Red LED Current (A)} = 0.0175 \times (\text{LED Current Value}) + 0.4495 \tag{1}$$

$$\text{Green LED Current (A)} = 0.0181 \times (\text{LED Current Value}) + 0.3587 \tag{2}$$

$$\text{Blue LED Current (A)} = 0.0160 \times (\text{LED Current Value}) + 0.1529 \tag{3}$$

Typical performance of the red, green, and blue LEDs are shown in [Figure 2](#), [Figure 3](#), and [Figure 4](#), respectively. Manufacturing processes can lead to variations in LED brightness and current consumption. Actual LED performance might vary from those shown in the following figures.

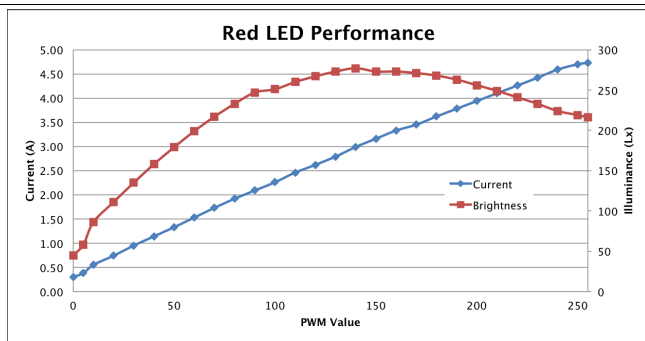

Figure 2. Typical Red LED Current and Illuminance Based on PWM Values

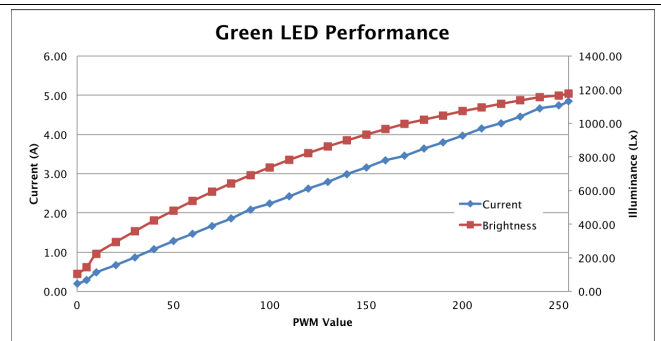

Figure 3. Typical Green LED Current and Illuminance Based on PWM Values

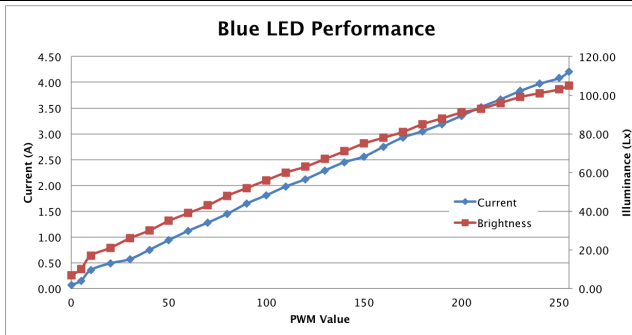

Figure 4. Typical Blue LED Current and Illuminance Based on PWM Values

CAUTION

The DLP LightCrafter 4500 is an actively cooled system that has a thermal limit resulting in total simultaneous red, green, and blue LED currents less than 4.3 A for continuous LED operation. Do not overheat the system by turning all LEDs at maximum power during prolonged and simultaneous LED use. Exceeding more than 4.3 A for continuous or simultaneous LED operation can damage the DLP LightCrafter 4500 LEDs.

Typical variations in LED manufacturing can lead to changes in the brightness and current consumption. Thus for typical white balance point, TI recommends the following percentages of colors:

- Red or green is approximately 87.5%
- Blue or green is approximately 97.6%

At the default LED current values of:

- Red = 104
- Green = 135
- Blue = 130

The *LED Selection* box determines the control of the LED enables signals. Two options are allowed:

- *Automatic*: LED enables are controlled by the DLPC350 sequencer. In *Video Mode*, the LED enables are set in color sequential order. In *Pattern Sequence* mode, the LED enables are controlled by the downloaded *Pattern Sequence* settings.
- *Manual*: LED enables are controlled by the check boxes. Checking a color, continuously enables the LED of that color at the given LED current setting.

3.2.5 Video Mode

When the DLP LightCrafter 4500 is configured in *Video Mode*, the *Input Source Select* section in [Figure 3-1](#) in the top-left part of the *Video Mode* tab selects the input source to be displayed by the DLPC350. The DLPC350 treats these as video inputs and applies image processing functions, like scaling, gamma correction, color coordinate adjustments, and so forth. The following lists the allowable input sources:

- Parallel RGB interface: Supports 24-, 20-, 16-, 10-, and 8-bit data inputs. This interface is connected to the TFP401 for DVI input from the mini-HDMI connector or to the system board connectors. The Pixel Data Format section is below the Source Select interface selects the allowable pixel data formats for the Parallel RGB interface:
 - RGB 4:4:4
 - YCrCb 4:4:4
 - YCrCb 4:2:2
- Internal Test Pattern: 24-bit internal pattern generator with RGB 4:4:4 pixel data format. The internal test patterns offer color control of the foreground and background color of the pattern through the *Internal Test Pattern Color* section. The available internal test patterns and their respective foreground and background color control are:
 - Solid field: Foreground color control only
 - Horizontal ramp: Foreground color control only
 - Vertical ramp: Foreground color control only
 - Horizontal lines: Foreground and Background color control
 - Diagonal lines: Foreground and Background color control
 - Vertical lines: Foreground and Background color control
 - Grid: Foreground and Background color control
 - Checkerboard: Foreground and Background color control
 - Red, green, and blue ramps: Foreground color control only
 - Color bar: Foreground color control only
 - Step bar: Foreground color control only
- Flash images: single-frame, 24-bit Still images stored in external flash memory. The flash memory supports up to 32MB of storage with up to 64 images. The images stored in flash memory support RGB 4:4:4 and YCrCb 4:2:2 pixel data formats.
- FPD-link: Flat Panel Display Link connector. The FPD-link interface supports 30-, 24-, 20-, 16-, 10-, and 8-bit data inputs with RGB 4:4:4 pixel data format. The *FPD Mode and Field Select* configures the mapping of the pixel mode, polarity, and CONT1 and CONT2 field signals.

For the Parallel RGB and FPD-link video input modes, the DLPC350 interprets channel A as green, channel B as red, and channel C as blue. However, the Parallel RGB or FPD-link source can have different mapping of channels to colors. The *Input Source Port Data Swap* section sets the mapping of channels to colors. Port1 refers to Parallel RGB interface while Port2 refers to the FPD-link interface. The mapping options are:

- ABC → ABC, no swapping of data subchannels
- ABC → CAB, data subchannels are right-shifted and circularly rotated
- ABC → BCA, data subchannels are left-shifted and circularly rotated
- ABC → ACB, data subchannels B and C are swapped
- ABC → BAC, data subchannels A and B are swapped
- ABC → CBA, data subchannels A and C are swapped

For all video input modes, the *Display Dimensions* section defines the active displayed resolution. The maximum supported input and output resolutions for the DLP4500 0.45 WXGA DMD are 1280 pixels (columns) by 800 lines (rows). The display area settings set the first pixel column (*Start Pixel*) and the first line (*Start Line*) as well as, the numbers of pixels per line (total columns) and the number of lines per frame (total rows). This setting also provides the option to define a subset of active input frame data using pixel (column) and line (row) counts. In other words, this feature allows cropping of the source image as the first step in the processing chain.

For the Parallel RGB and FPD-link video input modes, the *Video Signal Information* section provides details about the video source connected to the DLP LightCrafter4500. These signal parameters can only be read from the device, they cannot be set in the section.

The Signal Status parameter has the following states:

- Processing: The video source VSYNC signal has not yet locked when the **Get Video Info** button was pressed
- Detected: The video source VSYNC signal has been locked
- Stopped: The DLP LightCrafter 4500 is no longer locking to the video source. This occurs in the Pattern Sequence modes when video port input pattern streaming is selected. This prevents a delay in pattern display if synchronization is temporarily lost with the video source.
- Lock Failed: The DLP LightCrafter 4500 was not able to lock to the incoming video source. Please see sections 6.7 and 6.8 in the DLPC350 datasheet on Input Pixel Interface Timing Requirements to verify the video input is meeting specifications.

3.3 Pattern Sequence Mode

When the DLP LightCrafter 4500 is configured in *Pattern Sequence* mode, the DLPC350 supports 1-, 2-, 3-, 4-, 5-, 6-, 7-, and 8-bit images with a 912 columns × 1140 rows resolution. These images are pixel accurate, meaning that each pixel corresponds to a micromirror on the DMD and is not processed by any of the video processing functions. Three subtabs control the *Pattern Sequence* settings: *Sequence Settings*, *Pattern Sequence Start/Stop/Pause*, *Trigger Controls*, and *LED Delay Control*.

3.3.1 Sequence Settings

A pattern sequence is composed of several patterns loaded from flash memory or streamed through the 24-bit RGB video port. Each individual pattern can have a specific set of LEDs illuminating it, a particular bit-depth, and an internal or external trigger. The *Sequence Settings* subtab lets the user define and set all the *Individual Pattern Settings*. The *Trigger Controls* subtab and the *LED Delay Control* subtab set the trigger and LED enable edge timings, respectively. The *Pattern Sequence Start/Stop/Pause* tab shows the pattern sequence validation status indicators and allows the user to play, pause and stop the sequence. [Figure 3-5](#) shows the DLP LightCrafter 4500 GUI with the *Pattern Sequence* tab selected.

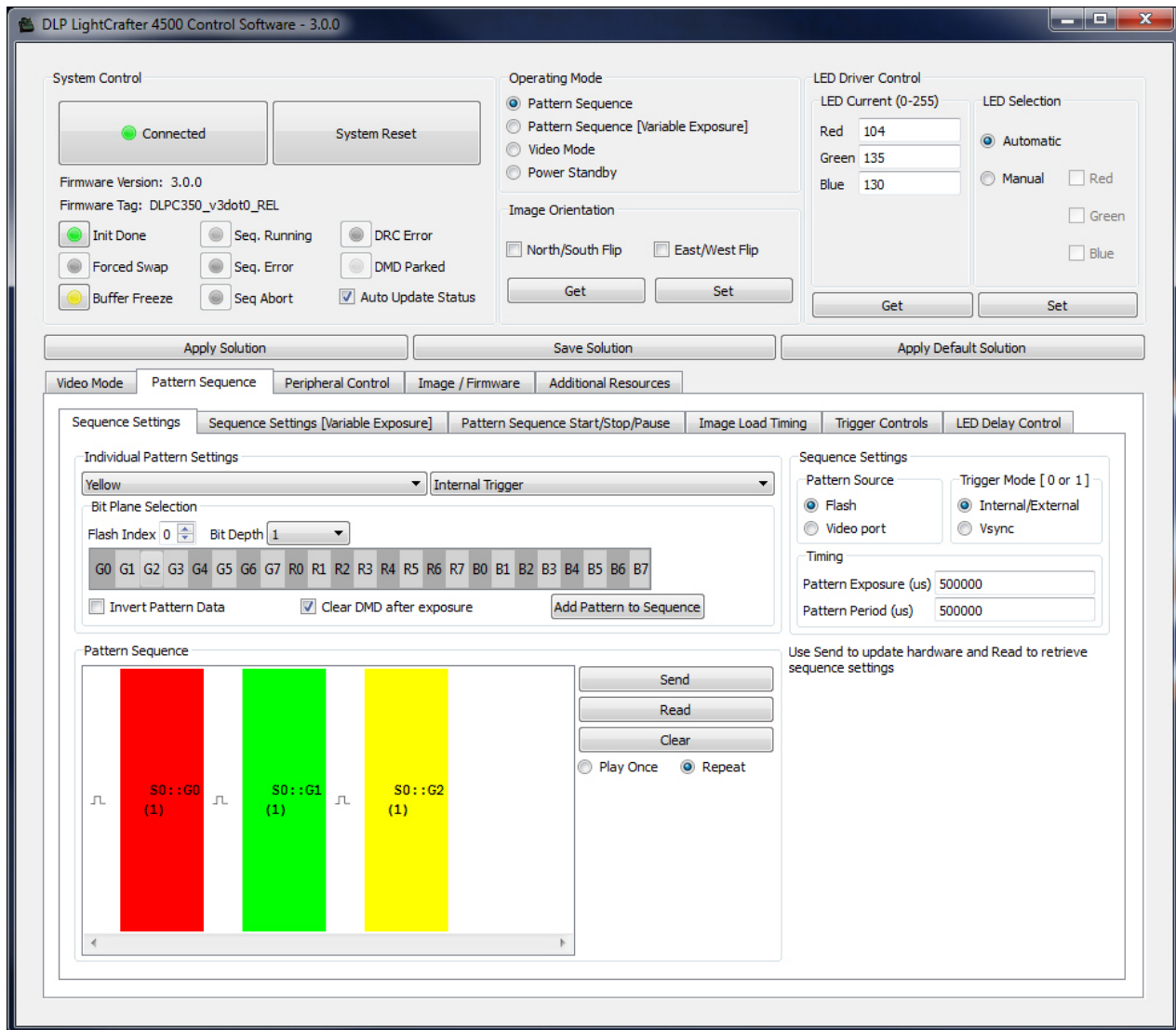

Figure 3-5. DLP LightCrafter 4500 GUI – Pattern Sequence Mode

The *Pattern Sequence* displays images from one of the following two input sources:

- *Flash*: Images stored in flash memory. The flash memory can store up to sixty-four 24-bit compressed images.
- *Video port*: Streamed through the Parallel RGB or FPD-link interface. Only one of these interfaces can be connected to the DLP LightCrafter 4500 during *Pattern Sequence* mode.

To synchronize a camera or external system with the displayed patterns, the DLP LightCrafter 4500 supports a set of trigger inputs and outputs. These inputs and outputs are configured through the *Trigger Mode* section and *Trigger Controls* subtab. The *Trigger Mode* selects the trigger input:

- *Internal/External*: Uses an internal trigger period to start the pattern sequence or uses the DLP LightCrafter 4500 TRIG_IN2 signal to start and pause the pattern sequence. Each pattern in the pattern sequence can be configured with either an internal or external trigger. With the *Internal Trigger* setting, the Internal Trigger Period displays the next pattern. With External Trigger Period, the DLP Light Crafter 4500 TRIG_IN_1 signal displays the next pattern.
- *Vsync*: Uses the VSYNC signal from the Parallel RGB or FPD-link interface to trigger the start of the pattern sequence. After VSYNC, the patterns are displayed in the sequence shown on the *Pattern Sequence* section. Each pattern length is determined by the Pattern Exposure time. Thus, the total number of patterns multiplied by the pattern exposure must be less than or equal to the VSYNC period.

Pattern sequence timing is controlled by the Pattern Period and Pattern Exposure time.

- Pattern Exposure (us): Defines the amount of time a single pattern is displayed in microseconds.
- Pattern Period (us): Defines the amount of time between patterns (in microseconds) in a pattern sequence.

A pattern sequence can be any combination of bit depth patterns with any combination of LED sources. The pattern sequence can be played once or continuously repeated. The allowed LED sources are:

- White: Red, green, and blue LEDs on
- Cyan: Green and blue LEDs on
- Magenta: Red and blue LEDs on
- Yellow: Red and green LEDs on
- Red: Only red LED on
- Green: Only green LED on
- Blue: Only blue LED on

To create a pattern sequence, follow these steps:

1. Choose pattern input source (Flash or Video port) from the *Pattern Source* section.
2. Choose Internal/External, or VSYNC trigger mode from the *Trigger Mode* section.
3. Set the appropriate *Trigger Controls*, see [Section 3.3.4](#)
4. Set the *Pattern Exposure* period and *Pattern Period*.
5. Create the pattern sequence in the *Individual Pattern Settings* section:
 - (a) Choose the LED(s) to illuminate this pattern in the pattern sequence
 - (b) Select the trigger for the pattern: no trigger, external positive, external negative, or internal trigger. **Internal trigger** has an internal hardware signal that is input to the pattern display state machine (meaning the controller starts displaying after receiving the signal), whereas the **no internal trigger** option will display a pattern without waiting for a trigger; each pattern will display in continuation with the previous pattern. Creating an internally triggered pattern sequence with an external trigger input may cause unexpected behavior.
 - (c) Choose the Flash Index (for Flash Pattern Source) or the Frame Index (for Video port Pattern Source) and set the bit depth for the pattern.
 - (i) Flash Index: This is the image's index in flash as bundled with the firmware loaded on the DLP LightCrafter 4500. These images can be viewed in Video mode by changing the Input Configuration > Source Select to Images from Flash
 - (ii) Frame Index: This value can be left alone. The patterns will be pulled from the specified bit-plane(s) from each transmitted video frame sequentially

Note: In pattern sequence mode, a group of images are sent in parallel rather than a single standard 24 bit RGB image, and anywhere from 3 8-bit images (grayscale) to 24 individual 1-bit images are sent. The color for each pattern in the sequence is determined by the LEDs selected when that pattern was added to the sequence.
 - (d) Select the desired pattern bit-depth to be displayed. The bit-planes are labeled G0 - G7, R0 - R7, and B0 - B7. Clicking on a rectangle will select this bit-plane. The grouping of bit-planes is determined by the bit-depth selected. The groupings cannot be changed. When the source is the video port, the trigger will always be VSYNC and the VSYNC period will be the total available time for displaying patterns (i.e. the video frame will be updated on each VSYNC). The number of patterns that can be displayed in this time is set by the pattern exposure and pattern period times selected.

Note that if using the video port, the incoming image resolution must be 912x1140
 - (e) If a black image is desired between patterns, check the Clear DMD after exposure.
 - (f) Click the **Add Pattern to Sequence** button.
 - (g) Repeat Steps through for each pattern in the sequence.

6. If the pattern sequence must be played once, set Play Once in [Figure 3-5](#). This setting will play the number of patterns set in the *Trigger Controls* subtab under **Trigger 2 Patterns per pulse**. If set to 1, it plays the first pattern in the sequence and stops. If set to 10, it plays the first 10 patterns in the sequence. If the pattern sequence is to continuously repeat, set to repeat. Make sure to click the **Send** button after clicking on *Play Once* to download the new settings. If *Video Port* is selected as the pattern source, *Play Once* may not work as expected. *Repeat* is the recommended setting for video input.
7. Clicking send will jump the GUI to the *Pattern Sequence Start/Stop/Pause* subtab as seen in [Figure 3-6](#). Clicking the **Validate Sequence** button executes a data validation and updates the Data Validation status indicators in this tab. If the data validates successfully, the pattern sequence is downloaded to the DLP LightCrafter 4500 and waits for the **Play** button to be pressed to start displaying the pattern sequence.
If a data validation problem occurs, the appropriate status indicators are highlighted in the Data Validation section:
 - *Exposure/Period OOR*: When highlighted red, the Pattern Exposure period or Frame period is out of range. The pattern exposure period must be greater than the fastest period supported, as listed in [Table 4-1](#).
 - *Pattern Number OOR*: When highlighted red, the Pattern Number is out of range. The maximum allowed patterns depend on the bit width and are listed in [Table 4-1](#).
 - *Cont trig out overlaps black*: When highlighted red, the continuous pattern exposure has a trigger Out1 request or overlapping black sectors.
 - *Black vector missing*: When highlighted red, the black vector is missing (this may also be referred to as the **post vector**).
 - *Period, Exposure diff < 230*: When highlighted red, the difference between the frame period or internal trigger period and the exposure period of a pattern is less than 230 μ s. The DMD needs 230 μ s for load a pattern, so the trigger or frame period must be 230 μ s greater than the pattern exposure time.
8. Pause or restart the pattern sequence through the **Pause** and **Play** buttons, respectively. If a pattern sequence was previously loaded, the user can click the **Read** button to load the sequence into the GUI window.

The *Pattern Sequence* section in the *Sequence Settings* tab shows the pattern sequence as a set of colored rectangles. The color corresponds to the LEDs used. The entries on the rectangles represent the image source, the bit-plane, and the bit-depth as follows: S0::G0 (1) indicates flash location 0, bit-plane = G0, bit-depth = 1. F2::G5 (3) indicates Frame 2, bit-plane = G5, bit-depth = 3. For example, in [Figure 3-5](#), a pattern sequence of three patterns is displayed. Each pattern is triggered every 500 ms and exposed for 500 ms. The first pattern is a 1-bit red pattern using bit-plane G0 from flash location 0. The second pattern is a 1-bit green pattern using bit-plane G1 from flash location 0. The third pattern is a 1-bit yellow pattern using bit-plane G2 from flash location 0.

A pulse icon in between the patterns indicates that a trigger is needed between the patterns. Right-clicking on this icon allows the removal of the trigger, so two or more patterns can share the same trigger and are exposed in sequence for the total exposure time. Right-clicking on a pattern allows the option of inverting the pattern, removing the pattern, or inserting a black image by clearing the DMD after exposure time.

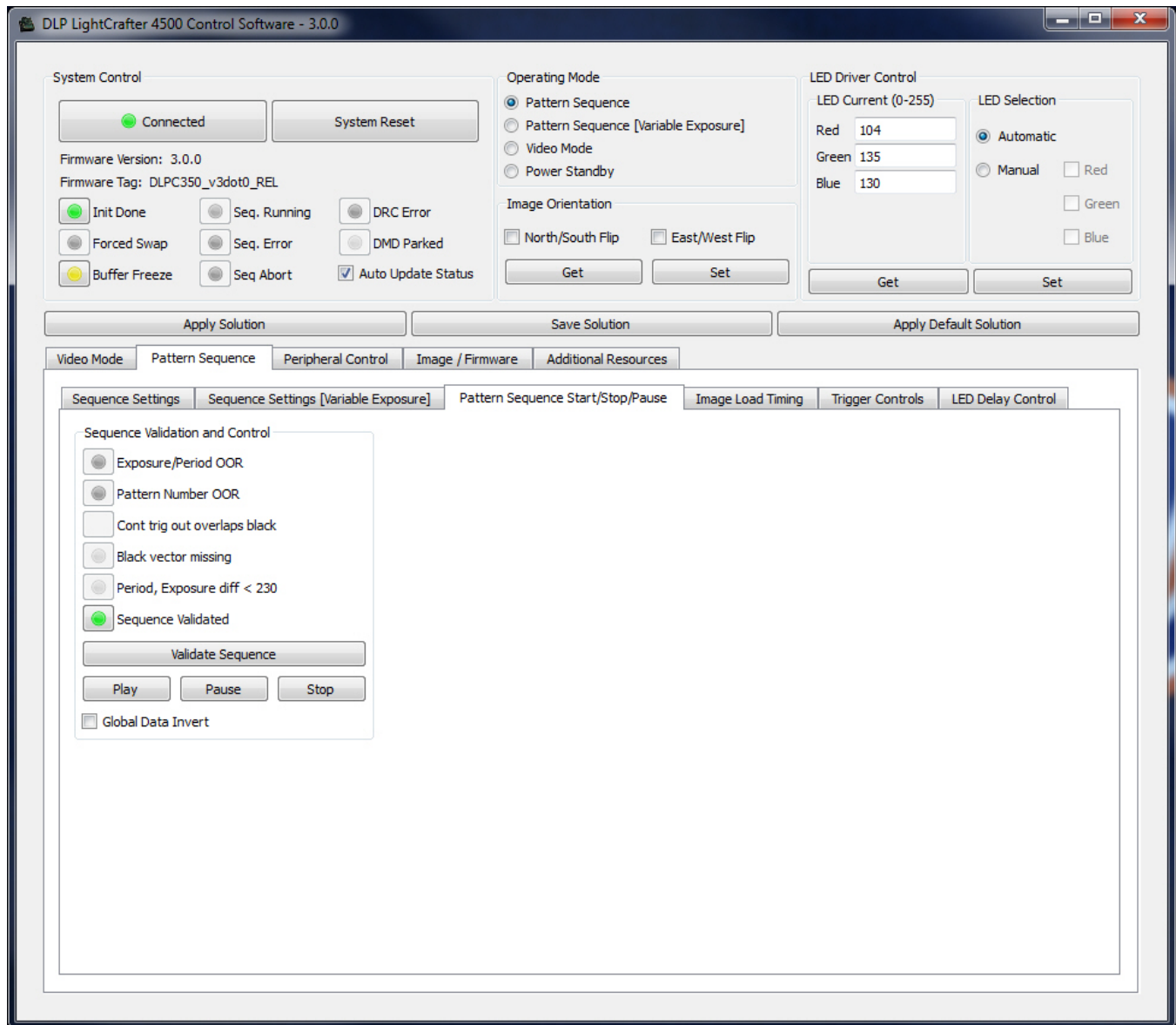

Figure 3-6. Pattern Sequence Mode: Start, Pause, Stop

3.3.1.1 Pattern Sequence Example

To illustrate the *Pattern Sequence* mode, this section describes the steps to create a sequence with Green LED. The DLPC350 firmware has several sets of images stored in the flash memory. Flash Image 1 corresponds to 24 1-bit images (vertical columns) that have been packed into a single 24-bit RGB bitmap. To load the pattern sequence, perform the following steps:

- Select *Pattern Source*: Flash
- Select *Pattern Trigger Mode*: Internal or External
- Set *Pattern Exposure*: 100000 μ s
- Set *Pattern Period*: 100000 μ s
- From the *Individual Pattern Settings*: Select *Green* and *Internal Trigger*
- *Flash Image*: Select 1
- For each 24 bit-plane of the packed 24-bit RGB image, select one bit-plane (a monochrome image) and add it to the pattern sequence by:

- Clicking on G0, then clicking the **Add Pattern to Sequence** button
- Clicking on G1, then clicking the **Add Pattern to Sequence** button
- Clicking on G2, then clicking the **Add Pattern to Sequence** button
- Clicking on G3, then clicking the **Add Pattern to Sequence** button
- Clicking on G4, then clicking the **Add Pattern to Sequence** button
- Clicking on G5, then clicking the **Add Pattern to Sequence** button
- Clicking on G6, then clicking the **Add Pattern to Sequence** button
- Clicking on G7, then clicking the **Add Pattern to Sequence** button
- Clicking on R0, then clicking the **Add Pattern to Sequence** button
- Clicking on R1, then clicking the **Add Pattern to Sequence** button
- Clicking on R2, then clicking the **Add Pattern to Sequence** button
- Clicking on R3, then clicking the **Add Pattern to Sequence** button
- Clicking on R4, then clicking the **Add Pattern to Sequence** button
- Clicking on R5, then clicking the **Add Pattern to Sequence** button
- Clicking on R6, then clicking the **Add Pattern to Sequence** button
- Clicking on R6, then clicking the **Add Pattern to Sequence** button
- Clicking on R7, then clicking the **Add Pattern to Sequence** button
- Clicking on B0, then clicking the **Add Pattern to Sequence** button
- Clicking on B1, then clicking the **Add Pattern to Sequence** button
- Clicking on B2, then clicking the **Add Pattern to Sequence** button
- Clicking on B3, then clicking the **Add Pattern to Sequence** button
- Clicking on B4, then clicking the **Add Pattern to Sequence** button
- Clicking on B5, then clicking the **Add Pattern to Sequence** button
- Clicking on B6, then clicking the **Add Pattern to Sequence** button
- Clicking on B7, then clicking the **Add Pattern to Sequence** button
- This forms 24 1-bit images that are displayed back-to-back at 100-ms exposure. Click on the **Send** button to download the pattern sequence to the DLP LightCrafter 4500.

3.3.2 *Sequence Settings [Variable Exposure]*

When operating in Pattern Sequence [Variable Exposure] mode, use this subtab to set the sequence settings. All of the sections are identical to the Sequence Settings subtab with the exception that the Pattern Exposure time and Pattern Period are now set on a per pattern basis rather than set to the same values for all patterns in the sequence.

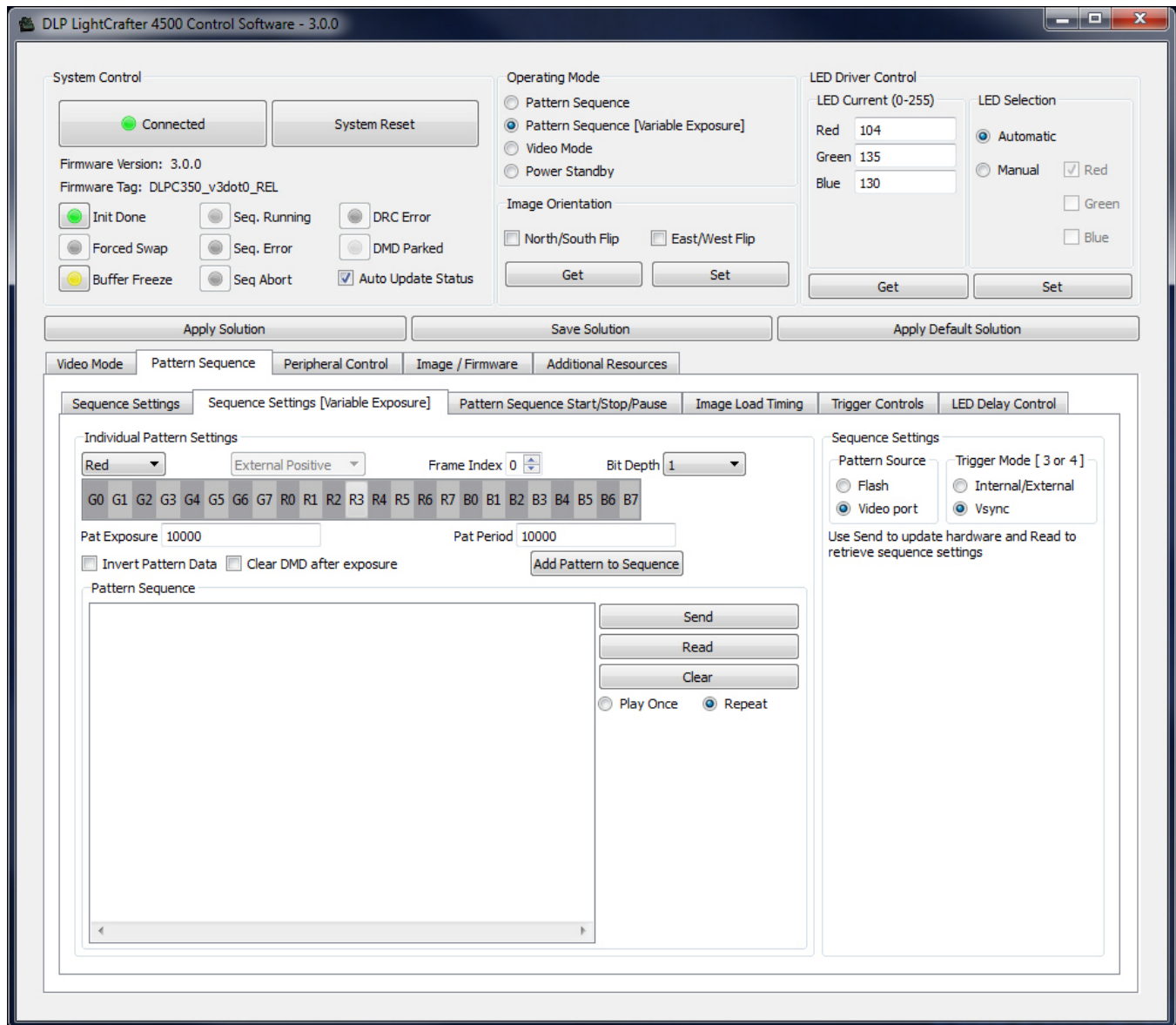

Figure 3-7. Pattern Sequence Mode — Variable Exposure

3.3.3 Image Load Timing

This subtab does an instant calculation on the time the DLPC350 takes to load a full 24-bit RGB bitmap from flash. This measurement is instantaneous and is not the average nor worst-case timing. To get an instantaneous measurement, perform the following steps:

1. Select the desired image number from Image Index.
2. Click the **Get Load Image Timing** button.

The DLPC350 decompresses the 24-bit RGB bitmap stored at the Image Index location and loads it to the internal buffer. The time required for this process is displayed in milliseconds. This feature overwrites the images currently in the display buffer.

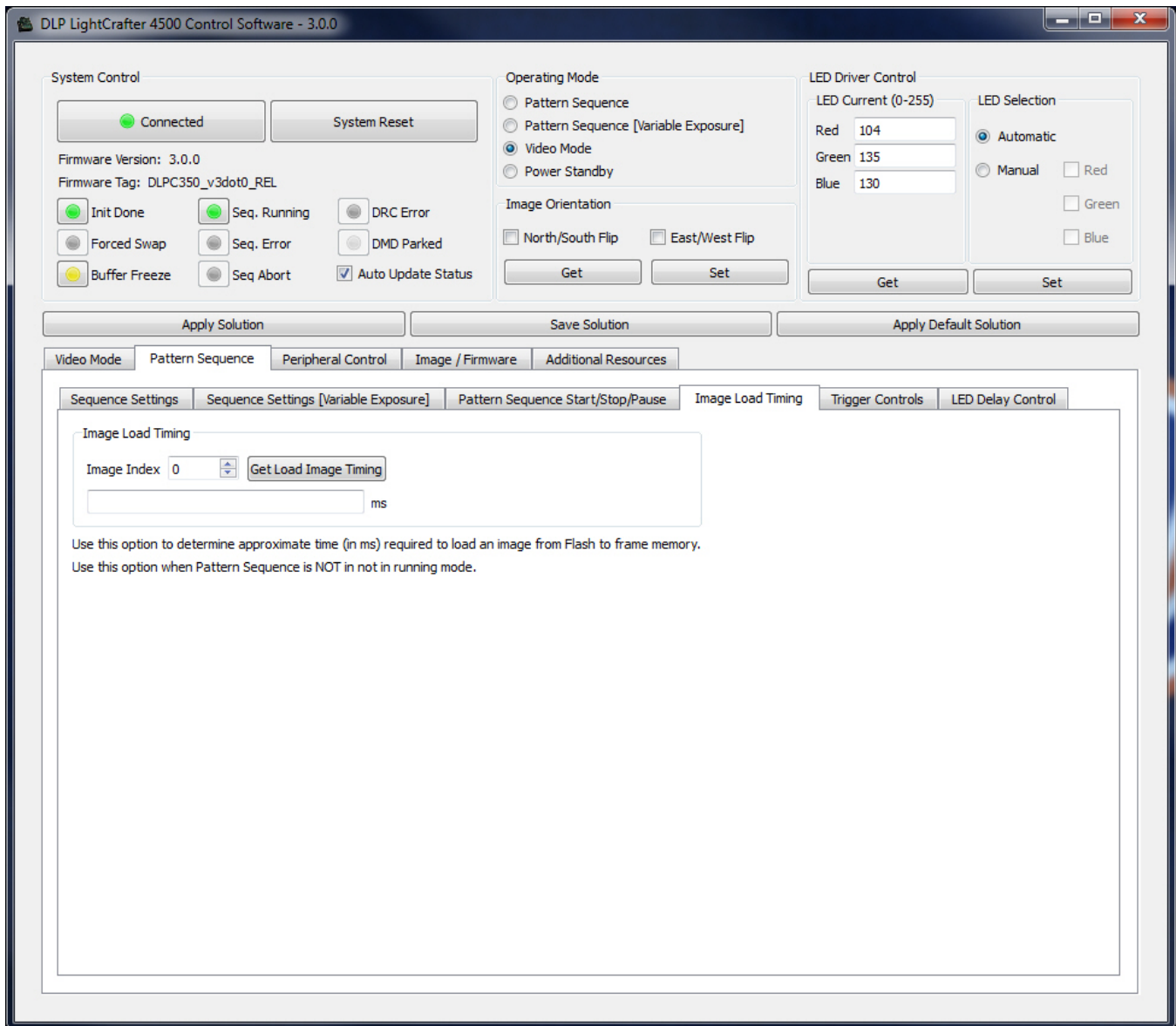

Figure 3-8. Image Load Timing

A typical time is 200 ms. Once an image is loaded from flash, 24 bit-fields reside in the frame buffer and can be sequenced at higher speeds. Two 24-bit field display buffers are available in the DLPC350. If the pattern sequence uses more than two images (48-bit fields), then approximately 200 ms is required to load the new image into the DLPC350 internal display buffer.

3.3.4 Trigger Controls

The *Trigger Controls* subtab sets the polarity and adjusts the rising and falling edge delay of the trigger inputs and outputs, see [Figure 3-9](#). The following trigger controls are available:

- TRIG_IN_1:
 - Trigger 1 In Delay: Sets the rising edge delay of the DLPC350 TRIG_IN_1 signal in relation to the display of the pattern on the DMD. Each number adds 107.136 ns. The GUI allows for delay ranges between 0 μ s and 28084.95 μ s, but for more information on how to extend the delay range, see the DLPC350 Programmer's Guide [DLPU010](#)
- TRIG_OUT_1:

- Trigger 1 Out Rising Edge Delay: Sets the rising edge delay of the DLPC350 TRIG_OUT_1 signal in relation to the display of the pattern on the DMD. Each number adds 107.136 ns. Range is $-20.05 \mu\text{s}$ (before pattern exposure) to $+2.79 \mu\text{s}$ (after pattern exposure) delay.
- Trigger 1 Out Falling Edge Delay: Sets the falling edge delay of the DLPC350 TRIG_IN_1 signal in relation to the display of the pattern on the DMD. Each number adds 107.136 ns. Range is $-20.05 \mu\text{s}$ (before the pattern exposure completes) to $+2.79 \mu\text{s}$ (after the pattern exposure completes) delay.
- Invert Trigger 1 Output: Sets the polarity of the TRIG_OUT_1 signal. When unchecked, the polarity of TRIG_OUT_1 is active high. When checked, the polarity of TRIG_OUT_1 is active low.
- TRIG_OUT_2:
 - Trigger 2 out Rising Edge Delay: Sets the rising edge delay of the DLPC350 TRIG_OUT_2 signal in relation to the display of the pattern on the DMD. Each number adds 107.136 ns. Range is $-20.05 \mu\text{s}$ (before pattern exposure) to $+7.29 \mu\text{s}$ (after pattern exposure) delay.
 - Invert Trigger 2 Output: Sets the polarity of the TRIG_OUT_2 signal. When unchecked, the polarity of TRIG_OUT_2 is active high. When checked, the polarity of TRIG_OUT_2 is active low.
 - Trigger 2 Patterns per Pulse: Indicates the number of patterns per TRIG_OUT_2 pulse.

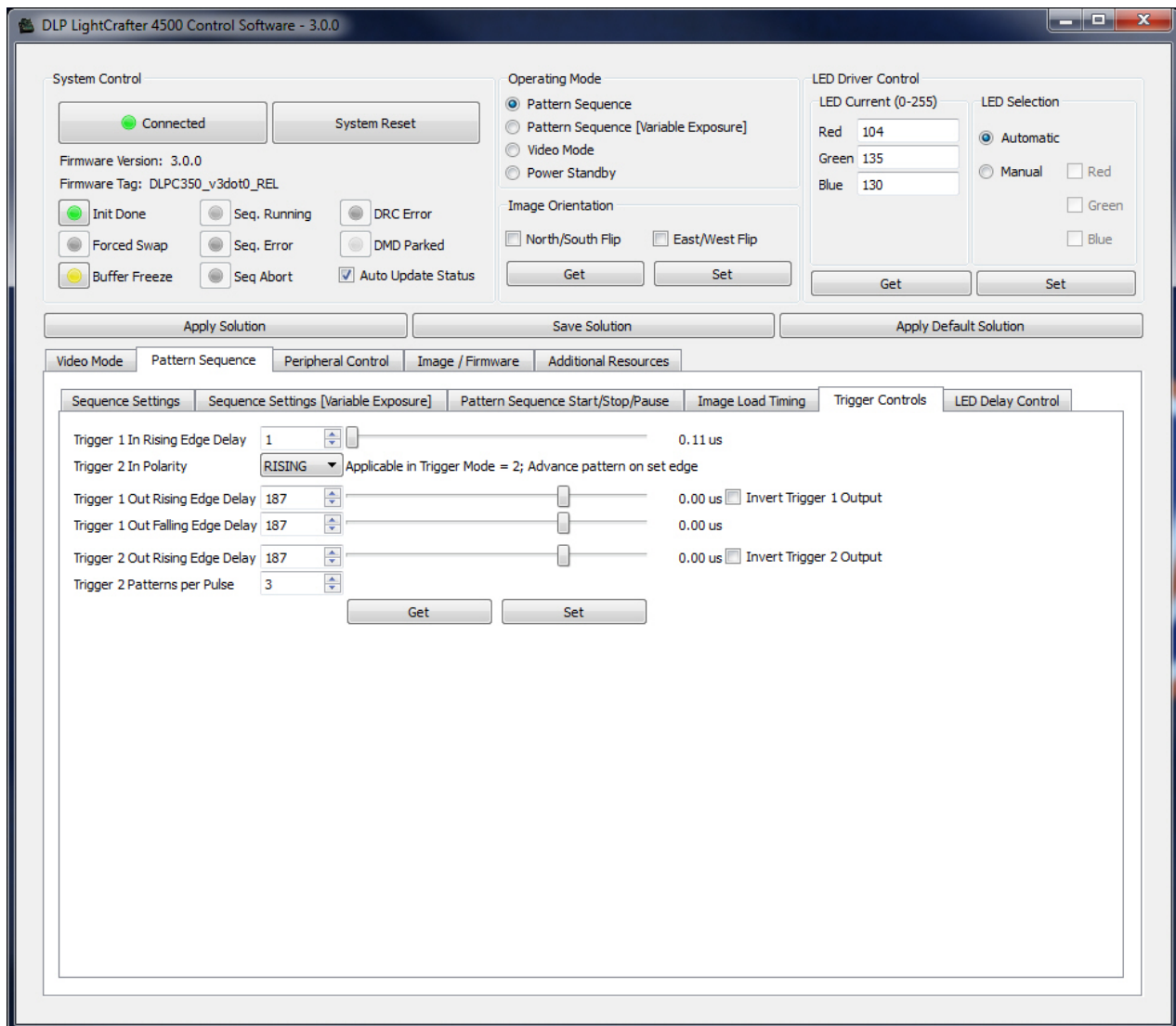

Figure 3-9. Trigger Control Subtab

The trigger output signals are:

- TRIG_OUT_1 frames the exposure time of the pattern.
 - TRIG_OUT_2 indicates the start of the pattern sequence or internal buffer boundary of a 24-bit-plane.
- examples of signals [Figure 3-10](#) and [Figure 3-11](#) show.

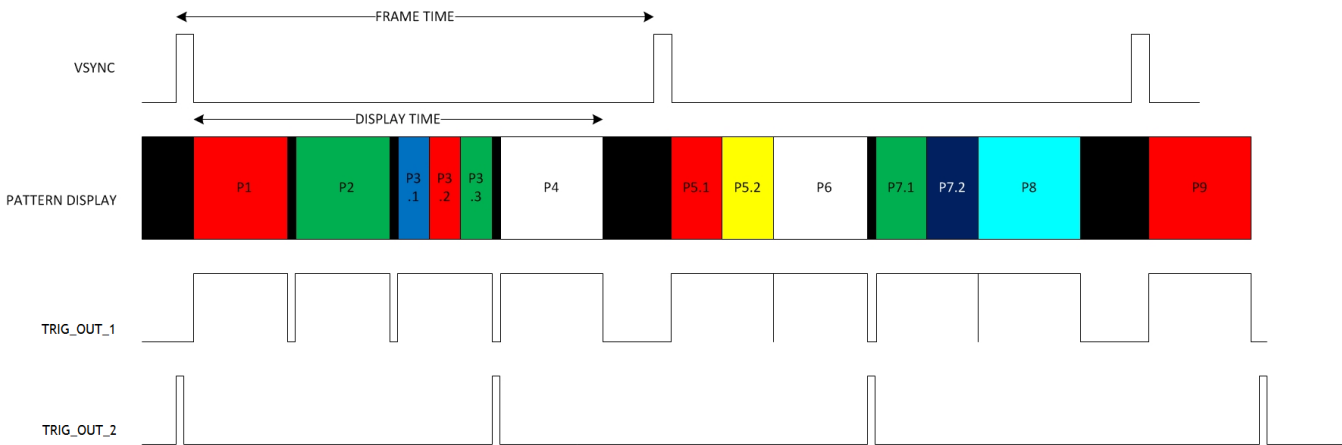

Figure 3-10. VSYNC Pattern Trigger Mode

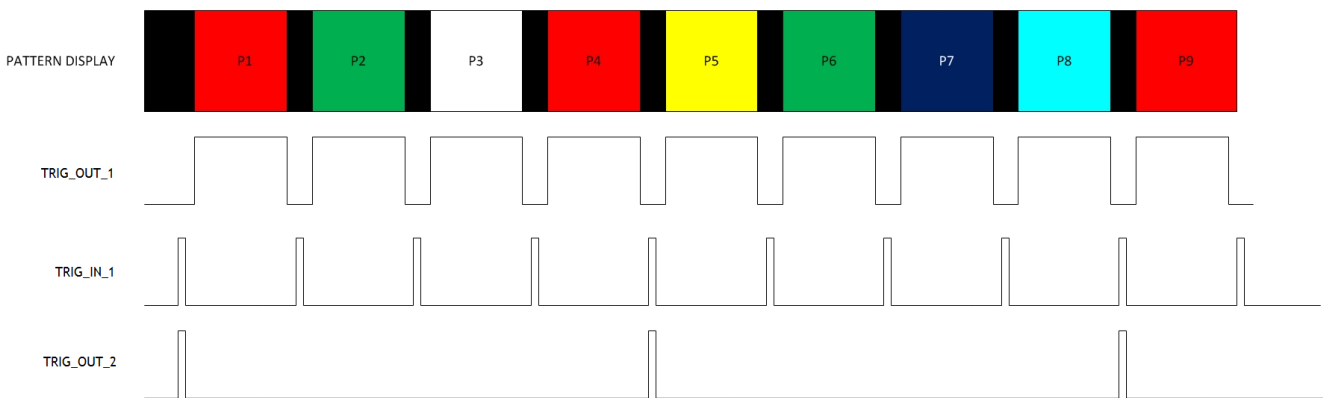

Figure 3-11. External Pattern Trigger Mode

3.3.5 LED Delay Control

In *Pattern Sequence* mode, the *LED Delay Control* subtab (see [Figure 3-9](#)) sets the rising and falling edge offsets of the LED enable signals in relation to the display of the pattern on the DMD. The rising and falling edge of the red, green, and blue LED enable signals can be independently changed between $-20.05 \mu\text{s}$ (before pattern exposure) to $+7.29 \mu\text{s}$ (after pattern exposure) delay.

When the DLP LightCrafter 4500 is operating in *Video Mode*, set these delays to 0 ($-20.05 \mu\text{s}$).

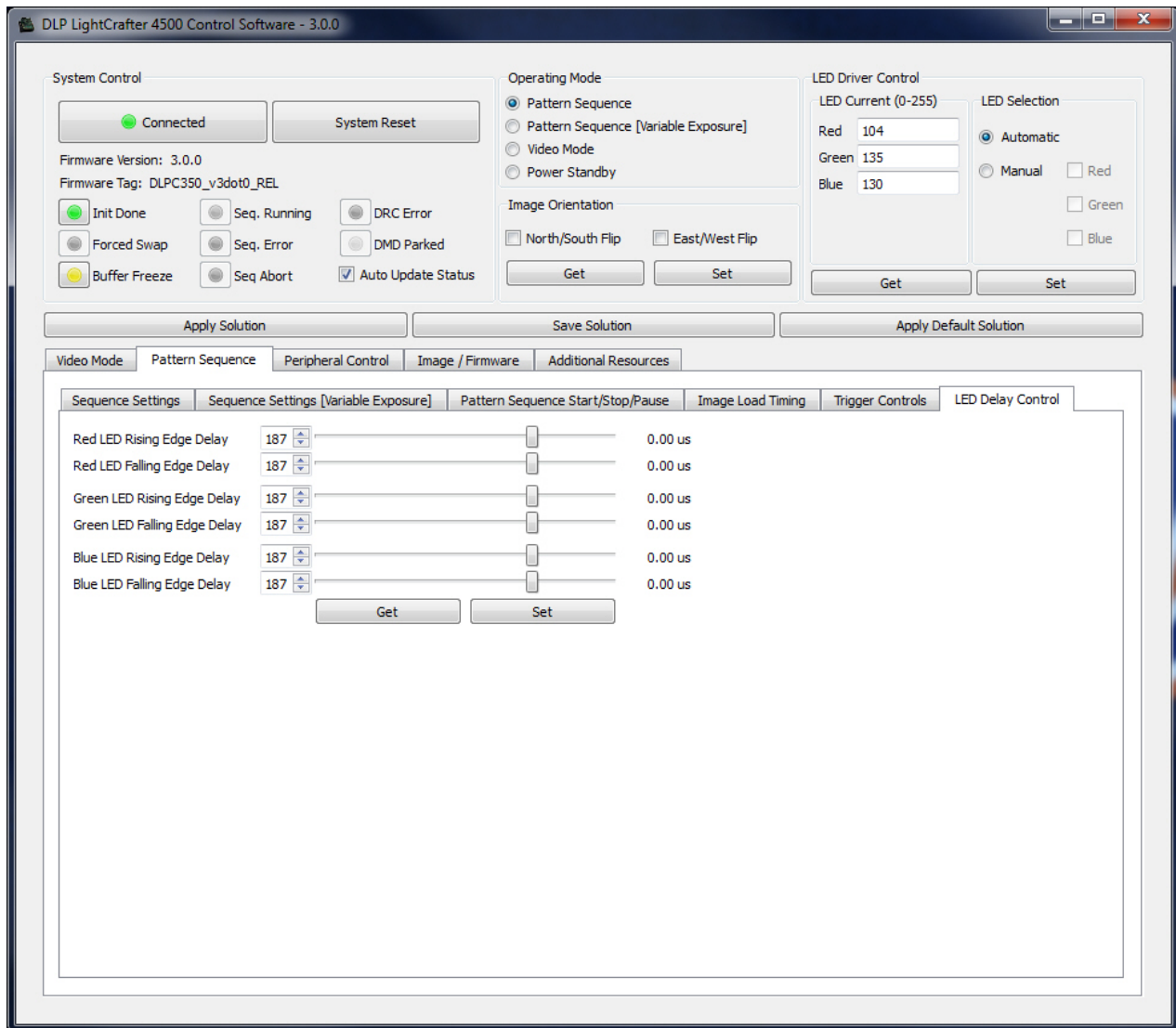

Figure 3-12. LED Delay Control Subtab

3.4 Firmware Upgrade

The DLP LightCrafter 4500 GUI allows field updates of the DLPC350 firmware. To update the DLPC350 firmware, perform the following steps [Figure 3-13](#)

1. Select the *Image / Firmware* tab and the *Firmware Upload* subtab.
2. Click the *Browse* button to select the file to install.
3. Mark the **Skip Bootloader update** and **Fast Flash Update** checkboxes based on preferences. If **Skip Bootloader Update** is selected, the memory sectors holding the bootloader will not be programmed. **Fast Flash Update** will create a local cache of the uploaded firmware on the system and the GUI will compare future firmware uploads to this local cache and only reprogram the portions which have been changed.
4. Click the **Upload** button.
5. Wait for the upload process to complete. The flash memory is erased first, then rewritten with the new firmware image selected.

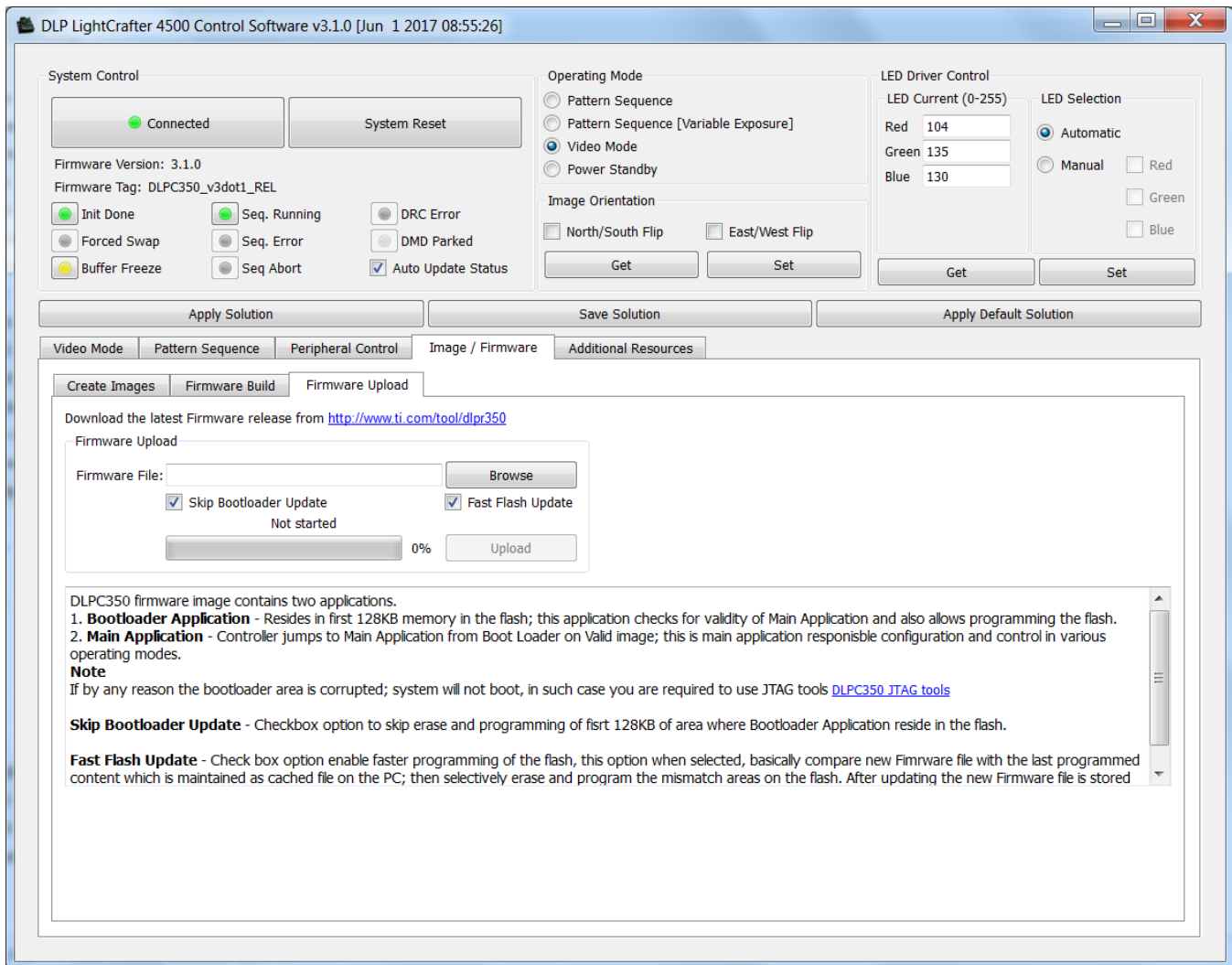

Figure 3-13. Firmware Upgrade Tab

3.5 Storing Images in Flash Memory

LightCrafter 4500 allows images to be compressed and stored into the 32-MB flash memory. For most efficient storage and compression of images, stored images are packed into groups of 24-bit RGB bitmap images and decompressed on the fly while loaded from flash memory. To ease the packing of any bit width images, the LightCrafter 4500 GUI offers the *Create Images* subtab, see Figure 3-14. To create a 24-bit image from different multiple bit depth images, perform the following steps:

1. Select the *Image / Firmware* tab and the *Create Images* subtab.
2. Select a bitmap file with 912 columns by 1140 rows by clicking the ... button next to *Input bmp file*
3. Select Output bitmap file by clicking the ... button next to *Output bmp file*
4. For an input file, add the individual bit-planes by repeating the following process:
 - (a) Set the bit depth and the bit field position with the *Bit depth* and the *At bit position* pulldown selectors, respectively.
 - (b) Click the **Add to Output File** button. The current image is bit weighted and saved into the 24-bit image of the output file.

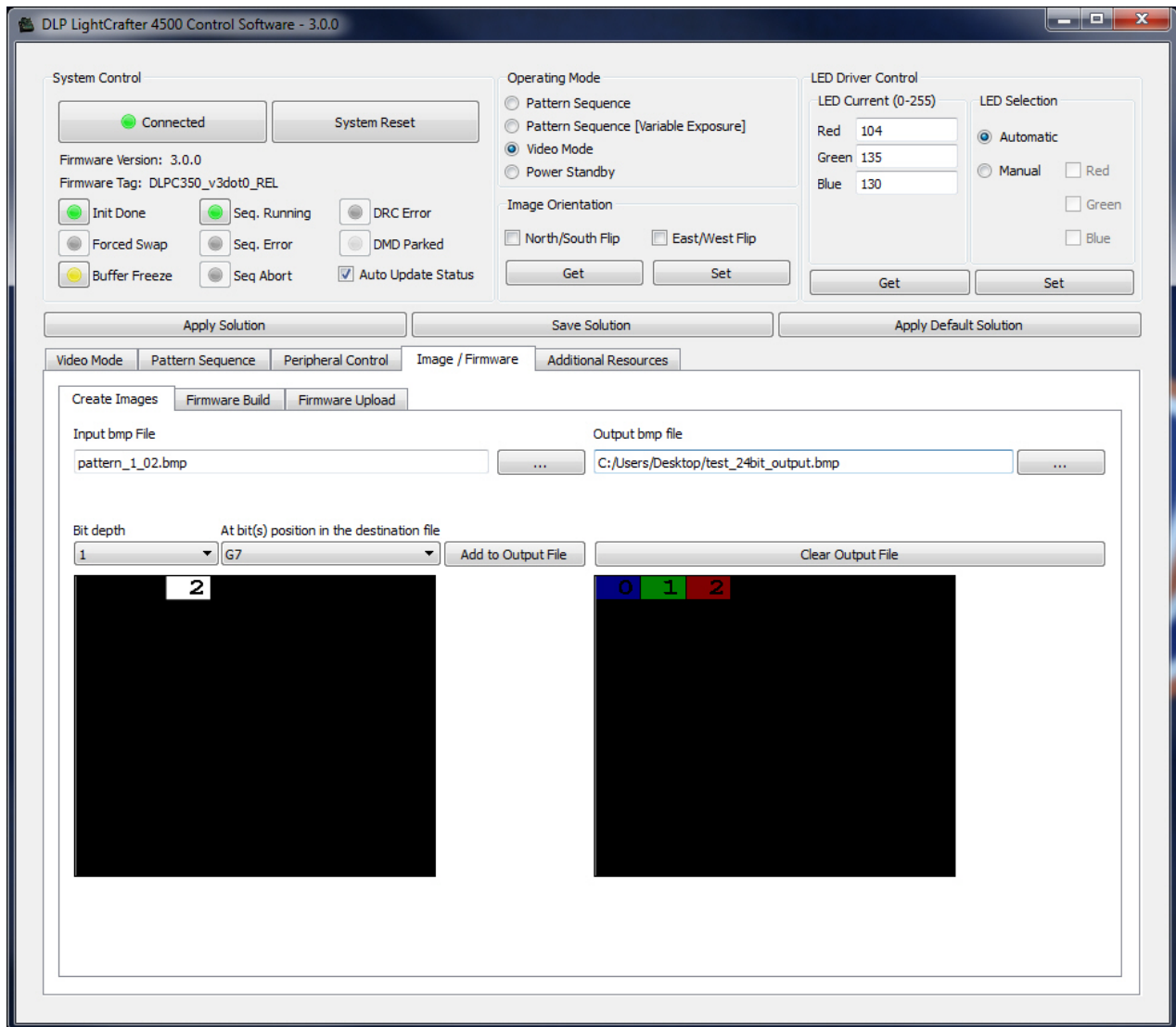

Figure 3-14. Create Images Tab

Underneath these selections, the left-hand window shows a preview of the Input file. The right-hand window shows a preview of the 24-bit output file that has taken all the input files and bit weighted the added images according to the bit-plane position requested. Images added at bit position B0 to B7 show blue, bit position G0 to G7 show red, and bit position R0 to R7 show green. This is due to the DLPC350 display order being GRB (see table 2-69, Pattern Number Mapping, in the DLPC350 Programmer's Guide), whereas BMP images are stored as RGB. For each color, bit position 0 is the least significant bit, while bit position 7 is the most significant bit.

To download the images into flash, a series of 24-bit images must be added to the firmware file using the *Firmware Build* subtab with the following steps:

1. Select the *Image / Firmware* tab and the *Firmware Build* subtab.
2. Select a firmware file by clicking the **Browse** button next to **Firmware File**.
3. If a new INI file is desired, refer to [Section 5.2](#) for details on creating a custom file. Use the **Select .ini File** button on the bottom left above the Save Updates button to select an existing INI file. Otherwise, leaving this field blank will bundle the Default.ini file in the GUI top level directory with this firmware build

4. Add a firmware tag. This is a 32 (or less) character string that will be associated with this firmware build. When the DLP LightCrafter 4500 connects to the GUI, the firmware tag is listed under the Firmware Version in the System Control section in the top left portion of the GUI. A firmware tag is required to build the firmware bundle.
5. Add 24-bit images by:
 - (a) Selecting the location of the image using the pull-down, and clicking the **Add** button. Browse the 24-bit image file and select it. The image is displayed next to these buttons. Repeat this step to add additional images.
6. Choose the type of illumination control that will be used with this firmware. If only a single color channel is being used, select **Monochrome** and check the box associated with the color channel in use. Otherwise, Select the **RGB Color** illumination option.
7. After completing the steps above, click the **Save Updates** button. A prompt for a firmware file name will appear. **User must include the .bin extension** in the name to avoid any errors. The GUI will then build and save the firmware.
8. Download the firmware to the DLP LightCrafter 4500 by following the steps for the Firmware Upgrade found in [Section 3.4](#).

After clicking **Save Updates**, all the 24-bit images are compressed and packed together. The number of the image might differ from the one in the pull-down due to the packing of the 24-bit images.

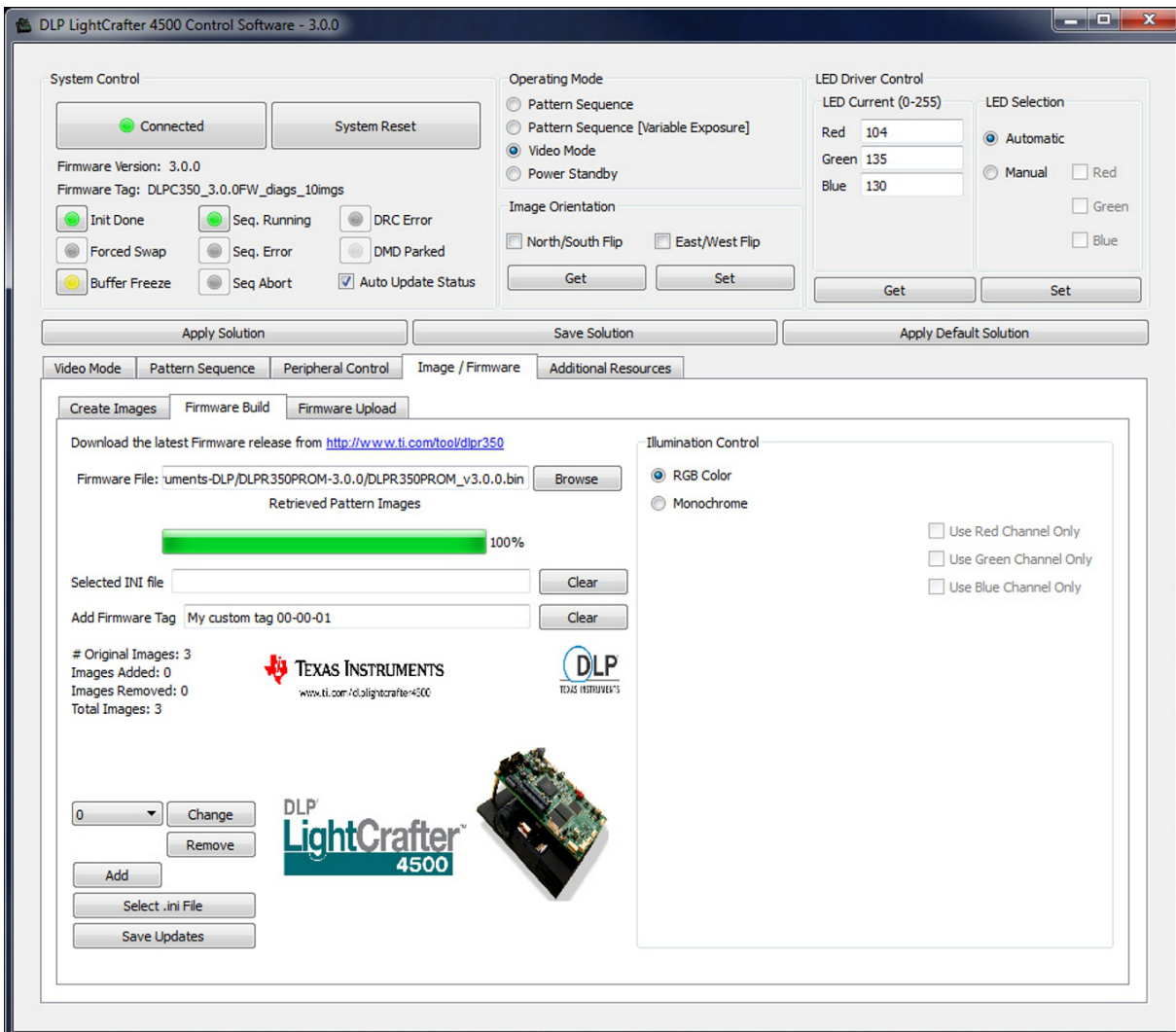

Figure 3-15. Firmware Builder

3.6 Peripheral Control

DLPC350 offers several configurable pins. The Peripheral Control tab of the GUI controls how these pins are configured. The following options are available:

- General Purpose Clock: Two DLPC350 pins can be individually configured as clocks.
- PWM Output Setup: Two DLPC350 pins, GPIO_00 (pin 18 in J6) and GPIO_02 (pin 22 in J6), can be individually set as PWM outputs.
- GPIO Configuration: Several DLPC350 pins can be individually configured as GPIO. Once configured as GPIO, the Pin Direction (Input or Output), if set to output the Pin State (High or Low) and output type (open drain output or drive high or low), can be configured. Some GPIO pins are already configured by the firmware for specific functions and these are listed with their current configuration.
- PWM Capture Setup: Two DLPC350 pins, GPIO_05 (pin 14 in J6) and GPIO_06 (pin 17 in J6), can be individually set as PWM inputs. These pins will sample at the frequency specified in PWM Sample Rate and report the duty cycle of the input signal.
- I2C0 (Master) Read/Write Control: The DLPC350 master I2C0 port can be accessed via the J16 connector on the DLP LightCrafter 4500. This section provide control over this port. The hex addresses and data should be in the format <value><space><value><space>... For example: 0x22 0x11. The number for bytes to be read is input as a decimal value.

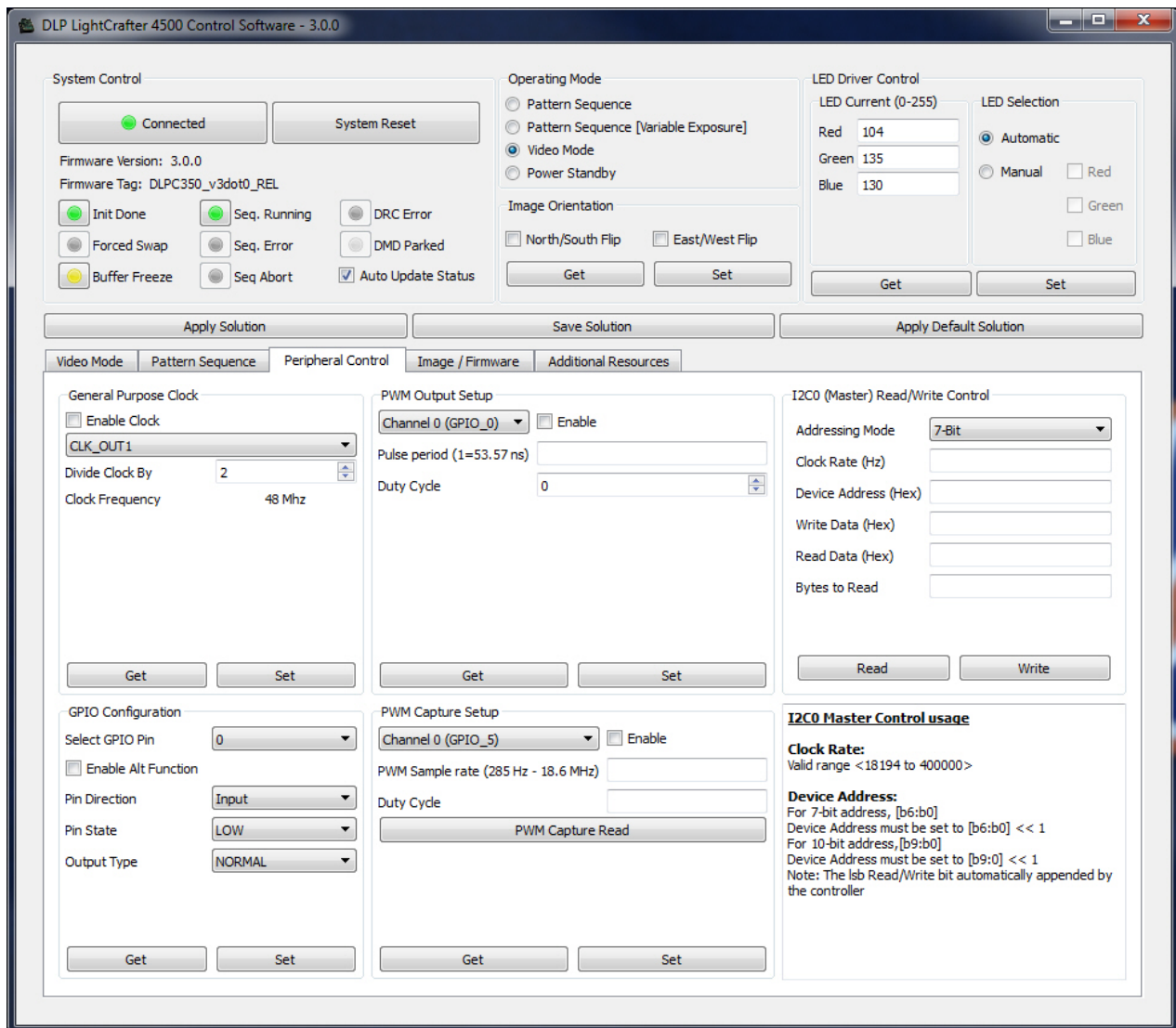

Figure 3-16. Peripheral Control Tab

Pattern Sequences

This chapter describes the pattern sequences supported by the DLP LightCrafter 4500 module.

4.1 Pattern Sequence Background

The DLPC350 takes as input 24-, 27-, or 30-bit RGB data at a frame rate of up to 120-Hz. This frame rate is composed of three colors (red, green, and blue) with each color equally divided in the 120-Hz frame rate. Thus, a 2.78-ms time slot is allocated to each color. Because each color has 8-, 9-, or 10-bit depth, each color time slot is further divided into bit-planes. A bit-plane is just a 1-bit representation of all the pixels in the image. For example, a 24-bit image is decomposed into its bit-planes in [Figure 4-1](#).

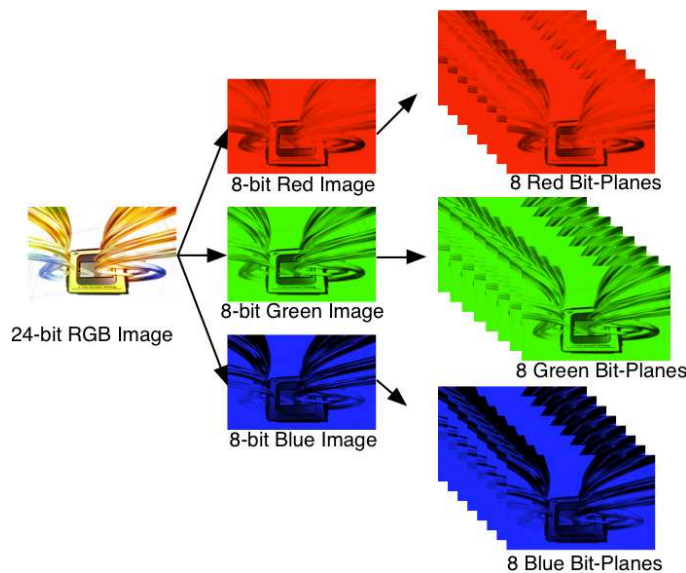

Figure 4-1. Relationship Between Bit-Planes and 24-bit RGB Images

The length of each bit-plane in the time slot is weighted by the corresponding power of 2 of its binary representation. This provides a binary pulse-width modulation of the image. For example, a 24-bit RGB input has three colors with 8-bit depth each. Each color time slot is divided into eight bit-planes, with the sum of all bit-planes in the time slot equal to 256. [Figure 4-2](#) shows this partition of bits in a frame.

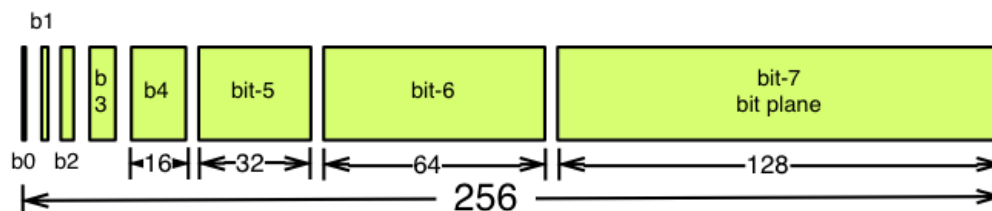

Figure 4-2. Bit Partition

Therefore, a single video frame is composed of a series of bit-planes. Because the DMD mirrors can be either on or off, an image is created by turning on the mirrors corresponding to the bit set in a bit-plane. With binary pulse-width modulation, the intensity level of the color is reproduced by controlling the amount of time the mirror is on. For a 24-bit RGB frame image loaded to the DLPC350, the DLPC350 creates 24 bit-planes, stores them in its internal display buffer, and sends the bit-planes to the DLP4500 DMD, one bit-plane at a time. Depending on the bit weight of the bit-plane, the DLPC350 controls the time this bit-plane is exposed to light, controlling the intensity of the bit-plane. To improve image quality in video frames, the bit-planes, time slots, and color frames are intertwined and interleaved with spatial-temporal algorithms by the DLPC350.

For other applications where this image enhancement is not desired, the video processing algorithms can be bypassed and replaced with a specific set of bit-planes. The bit depth of the pattern is then allocated into the corresponding time slots. Furthermore, an output trigger signal is also synchronized with these time slots to indicate when the image is displayed. For structured light applications, this mechanism provides the capability to display a set of patterns and signals for the camera to capture these patterns overlaid on an object.

As shown in Figure 4-3, the DLPC350 stores two 24-bit frames in its internal memory buffer. This 48 bit-plane display buffer allows the DLPC350 to send one 24-bit buffer to the DMD array while the second buffer is filled from flash or streamed in through the 24-bit parallel RGB or FPD-link interface. In streaming mode, the DMD array displays the previous 24-bit frame while the current frame fills the second 24-bit frame of the display buffer. Once a 24-bit frame is displayed, the buffer rotates providing the next 24-bit frame to the DMD. Thus, the displayed image is a 24-bit frame behind the data streamed through the 24-bit RGB parallel or FPD-link interface.

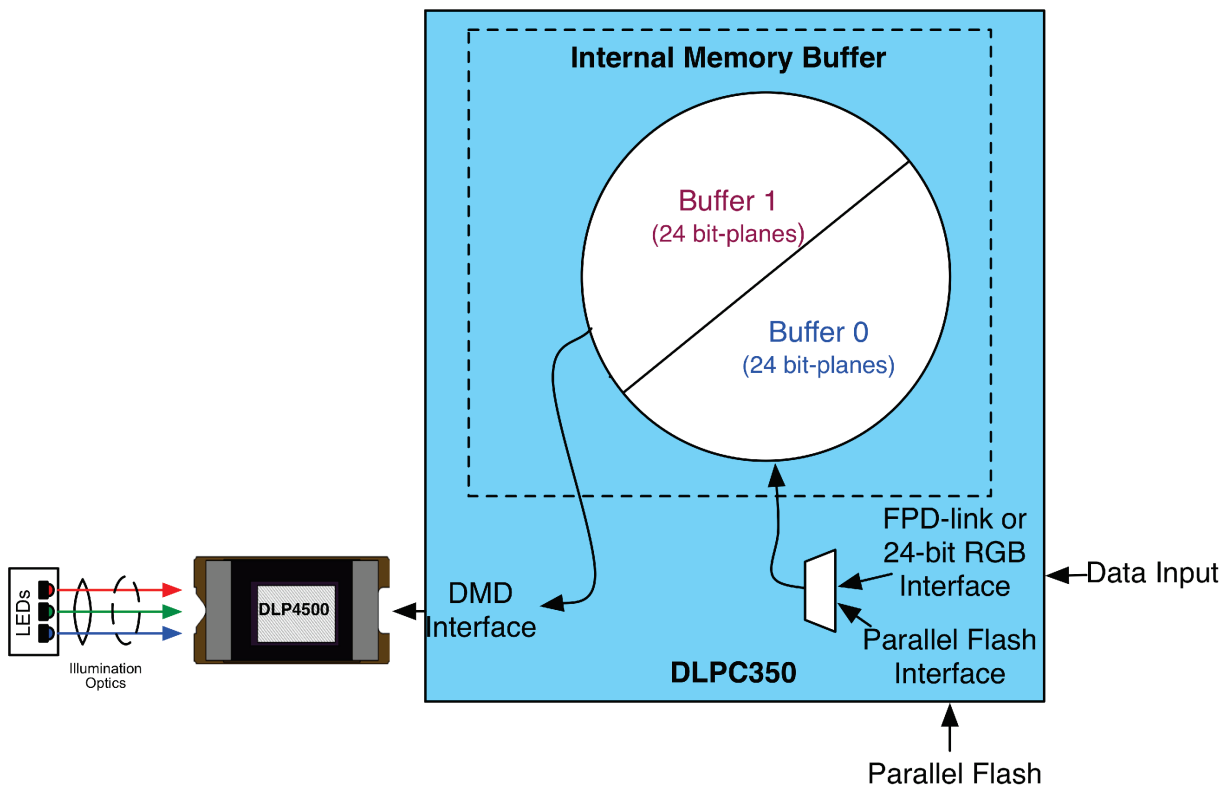

Figure 4-3. DLPC350 Internal Memory Buffer

When the DLP LightCrafter 4500 is set to *Video Mode*, the displayed image is a frame delayed in relation to the data streamed through the RGB parallel interface or FPD-link, as shown in Figure 4-4.

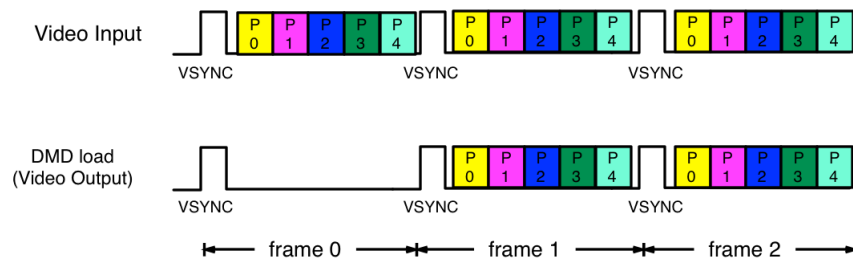

Figure 4-4. Frame Delay Between Parallel Interface Input and Projection Output

When the DLP LightCrafter 4500 is set to *Pattern Sequence* mode with pattern source from flash, the pattern sequence must be loaded from flash memory. The DLPC350 takes at-worst-case 200 ms to load one buffer (24 bit-planes). The actual time to load the buffer depends on the complexity of the image. The actual time is provided in the Image / Firmware tab under Image Load Time. If the pattern sequence is less than 24 bit fields, the patterns are displayed from a preloaded buffer. Once the patterns are loaded, the pattern sequence repeats from the internal display memory with no buffer load penalty. If the pattern sequence is greater than 24 bit-fields, the 24 bit-field pattern sequence display time must be longer than the full buffer load time. This provides enough time to load the next buffer while the current buffer is displayed. See [Figure 4-5](#) for a diagram of Image Load Time, Pattern Exposure Trigger period, and Internal Trigger period.

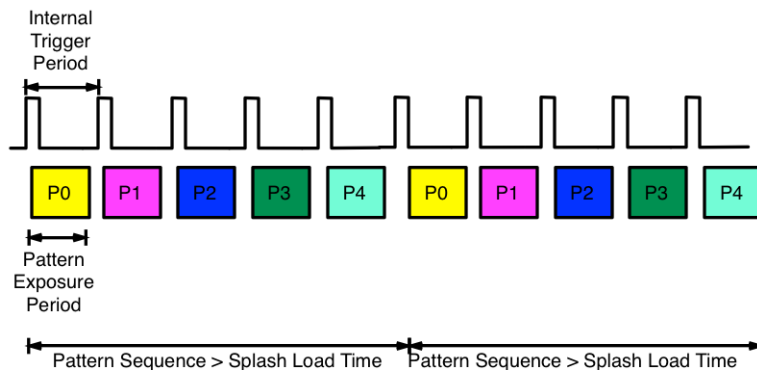

Figure 4-5. Image Load Time and Pattern Sequence Timing

In pattern sequence mode, the 48 bit-planes can be preloaded from flash memory and then sequenced with a combination of patterns with different bit depths. To synchronize a camera to the displayed patterns, the DLPC350 supports two trigger inputs and two trigger outputs. TRIG_IN_1 pulse indicates to the DLPC350 to advance to the next pattern, while TRIG_IN_2 starts and stops the pattern sequence. TRIG_OUT_1 frames the exposure time of the pattern, while TRIG_OUT_2 indicates the start of the pattern sequence or internal buffer boundary of 24 bit-planes. For example, in [Figure 3-10](#), the VSYNC starts the pattern sequence display. The pattern sequence consists of a series of three consecutive patterns. The first pattern sequence consists of P1, P2, and P3. P3 is an RGB pattern, it is shown with its time-sequential representation of P3.1, P3.2, and P3.3. The second pattern sequence consists of three patterns: P4, P5, and P6. The third sequence consists of P7, P8, and P9. TRIG_OUT_1 frames each pattern exposed, while TRIG_OUT_2 indicates the start of each of the three pattern sequences. In [Figure 3-11](#), a pattern sequence of a group of four patterns are displayed. TRIG_OUT_1 frames each pattern exposed, while TRIG_OUT_2 indicates the start of each four-pattern sequence. TRIG_IN_1 pulses advance the pattern.

[Table 4-1](#) lists the allowed pattern combinations in relation to the bit depth of the external pattern.

Table 4-1. Allowable Pattern Combinations

Bit Depth	External RGB Input Pattern Rate (Hz)	Preloaded Pattern Rate (Hz)	Minimum Pattern Exposure Period (μ s)	Maximum Number of Patterns using Two Buffers (PreLoaded)
1 bit	2880	4225	235	48
2 bits	1428	1428	700	24
3 bits	636	636	1570	16
4 bits	588	588	1700	12
5 bits	480	500	2000	8
6 bits	400	400	2500	8
7 bits	222	222	4500	6
8 bits	120	120	8333	6

Saving Solutions

On GUI software version 1.2 or later, any of the parameters set on the GUI can be stored as a solution. This solution can later be recalled with a single button or set to run as default on powerup. Temporary solutions are essentially .ini files that contain all the current parameter settings on the GUI. The .ini file is stored on the PC. To create a new default solution, the .ini file must be built into a new firmware image. This chapter describes the processes for creating, loading, and storing solutions.

5.1 Applying Solutions

This feature refers to the temporary solutions saved as .ini files on the PC. Three buttons in the static panel of the GUI control the application and creation of these solutions: **Apply Solution**, **Save Solution**, and **Apply Default Solution**.

- **Apply Solution:** Click this button to browse for .ini solutions that are already saved. Upon selecting an .ini file, the corresponding parameters update in the GUI. Parameters the user cannot change in the GUI (version number and splash time-out) do not take effect.
- **Apply Default Solution:** This button restores the settings to match those of the original DLPC350 firmware. Clicking this button is effectively the same as saving a solution and only selecting the values in the first column of radio buttons.
- **Save Solution:** Click this button to make a new window with a list of several parameters (described in [Section 5.3.1](#)) appear. One column of radio buttons contains the values set in the original DLPC350 firmware. The second column of radio buttons contains the values currently set in the GUI. The user can select either the original or current values to store in the .ini file

5.2 Changing Default Solutions

This feature refers to the process of taking an .ini file and building it into a new firmware image. The following procedure should be followed:

1. Select the Image / Firmware tab and the Add Images to Firmware subtab.
2. Choose a base firmware file. The **Select .ini File** button becomes active and lets the user browse for an .ini file.
3. Once the .ini file is selected, click the **Save Updates** button to save a new firmware image file.
4. Upload this new .bin or .img file to the LightCrafter 4500. The LightCrafter 4500 boots with the settings specified in the .ini file, and returns to these settings if reset.

NOTE: There are a few limitations to the use of .ini files and saved solutions. The first is that any saved solution using video streaming mode or video source input will not work on startup due to the Lightcrafter 4500 needing time to lock onto a video source. All other settings will be configured as desired.

Second, connecting the Lightcrafter 4500 to the GUI pauses any running system activity. This means any saved solutions utilizing repeated pattern sequences on start up will be stopped once connected to the GUI.

CAUTION

Before saving an .ini to firmware, TI recommends first applying the solution. Wrong values or incorrect syntax can potentially damage the DLP LightCrafter 4500.

5.3 Modifying .ini Files

There are two ways to modify the .ini files. The first method is to use the **Save Solution** button on the GUI. The second method is to open the .ini file in a text file editor and edit it manually.

5.3.1 Available Parameters

Table 5-1 lists all available parameters. For more details read the Programmer's Guide ([DLPU010](#)).

Table 5-1. List of Available Parameters when Saving Solutions

Parameter Name	Programmer's Guide Command	Extra Notes
APPCONFIG.VERSION.SUBMINOR	Retrieve Firmware Version	Corresponds to: Application software patch number. Range: 0x0000 to 0xFFFF
DEFAULT.AUTOSTART	N/A	0x0 = Boot normally 0x1 = Boot in standby
DEFAULT.DISPMODE	Display Mode Selection	0x0 = Video mode 0x1 = Pattern display mode (will start pattern sequence after initialization and splash time-out)
DEFAULT.SHORT_FLIP	Short-Axis Image Flip	0x0 = Disable 0x1 = Enable
DEFAULT.LONG_FLIP	Long-Axis Image Flip	0x0 = Disable 0x1 = Enable
DEFAULT.TRIG_OUT_1.POL	Trigger Out1 Control	0x0 = Active high 0x1 = Active low
DEFAULT.TRIG_OUT_1.RDELAY	Trigger Out1 Control	Each can range from 0x00 and 0xD5
DEFAULT.TRIG_OUT_1.FDELAY		
DEFAULT.TRIG_OUT_2.POL	Trigger Out2 Control	0x0 = Active high 0x1 = Active low
DEFAULT.TRIG_OUT_2.WIDTH	Trigger Out2 Control	Range: 0x00 to 0xFF
DEFAULT.TRIG_IN_1.DELAY	Trigger In1 Control	Range: 0x00 to 0xFF
DEFAULT.TRIG_IN_2.POL	Trigger In2 Control	For Trigger mode 2 only
DEFAULT.RED_STROBE.RDELAY	Red LED Enable Control	Range: 0x00 to 0xFF
DEFAULT.RED_STROBE.FDELAY		
DEFAULT.GRN_STROBE.RDELAY	Green LED Enable Control	Range: 0x00 to 0xFF
DEFAULT.GRN_STROBE.FDELAY		
DEFAULT.BLU_STROBE.RDELAY	Blue LED Enable Control	Range: 0x00 to 0xFF
DEFAULT.BLU_STROBE.FDELAY		
DEFAULT.INVERTDATA	Pattern Display Invert Data	0x0 = Typical operation 0x1 = Inverted operation
DEFAULT.LEDCURRENT_RED	LED Driver Current Control	Range: 0x00 to 0xFF. On this reference design, 0x0 is the maximum PWM, and 0xFF is the minimum. If multiple LEDs are enabled simultaneously (pattern mode or manual operation), then be mindful of maximum current values for design.
DEFAULT.LEDCURRENT_GRN		
DEFAULT.LEDCURRENT_BLU		
DEFAULT.PATTERNCONFIG.PAT_EXPOSURE	Pattern Display Exposure and Frame Period	PAT_EXPOSURE must be less than PAT_PERIOD by at least 230 μ s, or it must be equal to PAT_PERIOD.
DEFAULT.PATTERNCONFIG.PAT_PERIOD		
DEFAULT.PATTERNCONFIG.PAT_MODE	Pattern Display Data Input Source	0x0 = Streaming patterns through video ports 0x3 = Flash memory

Table 5-1. List of Available Parameters when Saving Solutions (continued)

Parameter Name	Programmer's Guide Command	Extra Notes
DEFAULT.PATTERNCONFIG.TRIG_MODE	Pattern Trigger Mode Selection	0x0 = Vsync trigger 0x1 = Internal or external trigger 0x2 = Alternating trigger (not currently in GUI)
DEFAULT.PATTERNCONFIG.PAT_REPEAT	Pattern Display LUT Control	0x0 = Play once 0x1 = Repeat the pattern sequence
DEFAULT.PATTERNCONFIG.NUM_SPLASH	Pattern Display LUT Control	Must be less than 63 (where 0x0 = 1, and 0x3F = 64). Must equal number of items in DEFAULT.SPLASHLUT
DEFAULT.SPLASHLUT	Pattern Display LUT Data-Image Index	Flash image indexes in the order they appear in the pattern sequence. (Example: DEFAULT.SPLASHLUT 0x1 0x2 0x1 0x3 0x0 0x2)
DEFAULT.PATTERNCONFIG.NUM_LUT_ENTRIES	Pattern Display LUT Control	Must be less than 128 (where 0x0 = 1, and 0x7F = 128). Must equal number of items in DEFAULT.SEQPATLUT.
DEFAULT.PATTERNCONFIG.NUM_PATTERNS	Pattern Display LUT Control	If PATTERNCONFIG.PAT_REPEAT = 0x0, then should equal number of items in DEFAULT.SEQPATLUT. If PAT_REPEAT = 0x1, then should equal number of patterns between desired Trigger Out2 pulses.
DEFAULT.SEQPATLUT	Pattern Display LUT Data – Pattern Definition	Example for two patterns: DEFAULT.SEQPATLUT 0x00042100 0x00002104;
DEFAULT.PORTCONFIG.PORT	Input Source Selection	0x0 = Parallel interface 0x1 = Internal test pattern 0x2 = Flash 0x3 = FPD-Link
DEFAULT.PORTCONFIG.BPP	Input Source Selection	0x0 = 30-bit 0x1 = 24-bit 0x2 = 20-bit 0x3 = 16-bit 0x4 = 8-bit
DEFAULT.PORTCONFIG.PIX_FMT	Input Pixel Data Format	0x0 = RGB 0x1 = YCrCb 444 0x2 = YCrCb 422
DEFAULT.PORTCONFIG.PORT_CLK	Port Clock Select	0x0 = A (needed for this reference design) 0x1 = B 0x2 = C
DEFAULT.PORTCONFIG.ABC_MUX	Input Data Channel Swap Command	0x0 – ABC = ABC 0x1 – ABC = CAB 0x2 – ABC = BCA 0x3 – ABC = ACB 0x4 – ABC = BAC 0x5 – ABC = CBA
DEFAULT.PORTCONFIG.PIX_MODE	FPD-Link Mode and Field Select	0x0 = Mode 1 0x1 = Mode 2 0x2 = Mode 3 0x3 = Mode 4
DEFAULT.PORTCONFIG.SWAP_POL	FPD-Link Mode and Field Select	0x0 = Typical 0x1 = Inverted
DEFAULT.PORTCONFIG.FLD_SEL	FPD-Link Mode and Field Select	0x0 = CONT1 0x1 = CONT2 0x2 = Force 0
PERIPHERALS.I2CADDRESS[0]	I2C Interface in Interface Protocol Section	
PERIPHERALS.I2CADDRESS[1]		
DATAPATH.SPLASHSTARTUPTIMEOUT	N/A	Time in milliseconds before default image times out. Range: 0x0000 to 0xFFFF
DATAPATH.SPLASHSTARTUPENABLE	N/A	0x0 = Do not show a default image when board initializes (powerup or reset) 0x1 = Show a default image when board initializes (powerup or reset)

5.3.2 Save Solution Button

When this button is clicked in the GUI, a new window with a subset of parameters from [Table 5-1](#) appear. One column of radio buttons contains the original values of the DLPC350 firmware. The second column of radio buttons contains the values currently set in the GUI. Select which value or values are needed in the .ini file. This method is the preferred way of previewing syntax errors or invalid entries.

5.3.3 Manual Editing

The .ini files can be edited as text files. This method does not check syntax or validate commands. TI recommends this method only for editing those commands not available through the GUI (APPCONFIG.VERSION.SUBMINOR, DEFAULT.AUTOSTART, PERIPHERALS.I2CADDRESS, DATAPATH.SPLASHSTARTUPTIMEOUT, and DATAPATH.SPLASHSTARTUPENABLE). This method can be used with the LUT Helper Tool provided in the software bundle for DEFAULT.SPLASHLUT and DEFAULT.SEQPATLUT. For more information about the tool, [Section 5.3.4](#).

5.3.4 LUT Entry Helper Tool

The LUT Entry Helper Tool has four tabs. The first two tabs can be used to calculate the values for DEFAULT.SEQPATLUT and DEFAULT.SPLASHLUT. The second two tabs are for reference.

5.3.4.1 Pattern LUT Entries

This tab is used to calculate the values for DEFAULT.SEQPATLUT. The table with 128 possible entries can be modified with the desired parameters for each pattern in the pattern sequence. It is possible to customize various parameters for each pattern. Valid entries for each category below are found in the Data tab.

- BIT-DEPTH: Select between 1 and 8.
- PATTERN: Select the desired pattern number. Each bit-depth of n corresponds to a pattern number equal to $24 / n$. See the Pattern Bit-Planes tab to understand the mapping of bit-planes to pattern number.
- LED: Select which LEDs are on.
- TRIG IN: Select the type of trigger input that will trigger the current pattern. If streaming through the video port, the VSYNC acts as the External Positive trigger, and any subsequent patterns in the frame (between VSYNC pulses) have no trigger. These patterns are labeled with **Continue** in the Pattern Sequence window.
- PAT INVERT: Select whether or not to invert the pattern.
- INSERT BLK: Select whether to clear the DMD after each pattern or not. TI recommends clearing the DMD at least after the last pattern in the LUT.
- BUFF SWAP: This parameter indicates whether or not to move to the next flash image in the SPLASHLUT. Each time this is a yes, the SPLASHLUT index increments. The index returns to 0 if there are no more indexes.
- TRIG OUT: Either a new Trigger Out1 is generated (NEW) or the pattern shares exposure time with the previous pattern (PREV) and no output trigger is generated.

As the user changes the values in the LUT, the values in the LUT DATA column change. After entering the parameters for as many patterns as needed, scroll to the bottom of the sheet. Enter the total number of patterns next to N = (in cell C138). Then, row 139 generates the necessary values the user must copy into the .ini file.

Lastly, there is a Debug Helper tool at the bottom of this sheet. Enter a hex code where it says LUT DATA to find out what the corresponding parameters are.

5.3.4.2 Image LUT Entries

This tab is used to calculate the values for DEFAULT.SPLASHLUT. This tab converts the desired image indexes into hexadecimal values. Row 6 contains the calculated string of values for the .ini file. If the user repeats indexes, enter them separately. See this example in [Table 5-2](#); the order is 0, 13, 12, 1, 13, 12, 0, 13, 12, 1, 13, 12, and so on.

Table 5-2. Image LUT Entries Example

SL No.	1	2	3	4	5	6
Image Index in Decimal	0	13	12	1	13	12
DEFAULT.SPLASHLUT	0x0	0xD	0xC	0x1	0xD	0xC

PandaBoard Interface

This chapter describes the interface between the DLP LightCrafter 4500 and the PandaBoard ES.

6.1 PandaBoard 4500

PandaBoard ES is a low-cost, open-development platform based on the TI OMAP4 application processor. The PandaBoard ES is supported by a dedicated community at PandaBoard.org. The DLP LightCrafter 4500 combined with a PandaBoard ES provides users with an embedded platform that eliminates the need for a dedicated laptop or PC. The PandaBoard ES includes an OMAP4 1.2-GHz, dual-core processor, 1GB of onboard RAM, SD card slot, and a suite of connectivity options, including:

- Ethernet, *Bluetooth*[®]
- Wi-Fi
- USB 2.0
- HDMI output and a camera input connector.

The combination of PandaBoard ES with DLP LightCrafter 4500 allows for the creation of self-contained, high-precision mobile tools to meet a growing number of applications, such as inline machine vision systems, portable, high-accuracy 3D scanners, and field spectrometers.

To interface a PandaBoard ES with the DLP LightCrafter 4500, the following modifications are needed:

- Populate J1 with Samtec FW-10-04-F-D-570-140
- Populate J3 with Samtec ZW-14-10-F-D-415-200
- Populate J4 with Samtec FW-10-04-F-D-570-140
- Populate J6 with Samtec ZW-14-10-F-D-415-200
- Remove resistor R152 on the PandaBoard ES. The DLP LightCrafter 4500 powers the PandaBoard. Removing the resistor prevents the PandaBoard from being powered by the USB and conflicting with the DLP LightCrafter 4500 power.
- Add four metric male-female threaded hex standoffs with a length of 19 mm and a M3 screw size

Due to the tight tolerances in the J1, J3, J4, and J6 connectors alignment, TI recommends inserting these headers on the corresponding DLP LightCrafter 4500 connector before soldering. For ease of use, SVTronics[®] has created a custom-build option of the PandaBoard ES that includes the connectors and standoffs, and removes the R152 resistor, called [PandaBoard 4500](#). [Figure 6-1](#) shows a DLP LightCrafter 4500 with a PandaBoard 4500.

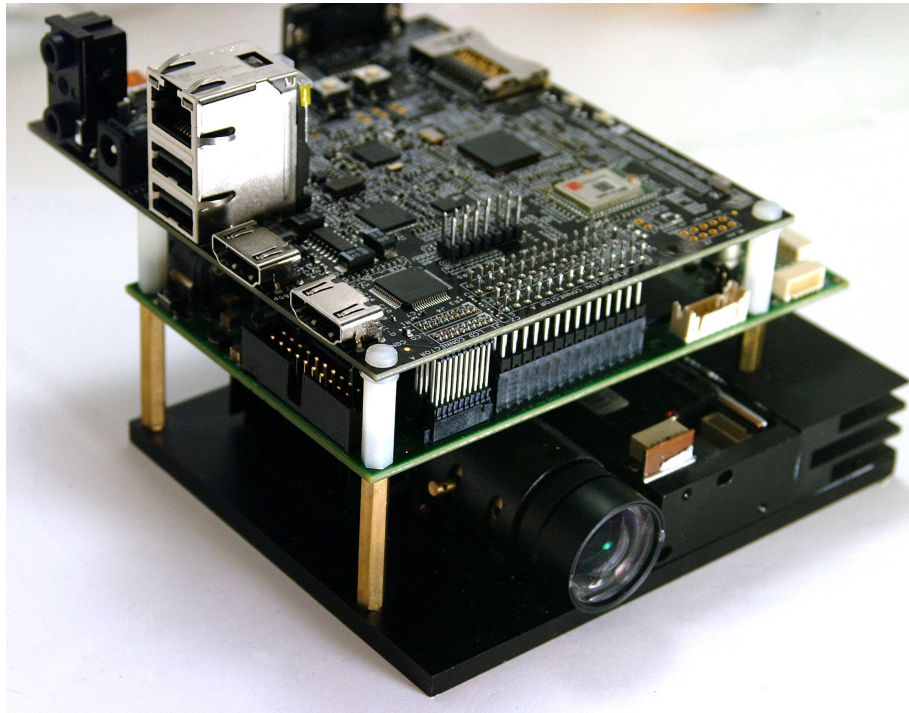

Figure 6-1. DLP LightCrafter 4500 With PandaBoard 4500

6.1.1 DLP LightCrafter 4500 to PandaBoard Interface

As shown in [Figure 6-2](#), the DLP LightCrafter 4500 supplies 5-V power to the PandaBoard. The PandaBoard provides 1.8 V to the DLP LightCrafter 4500 to level-shift all the signals interfacing the two boards together. The following OMAP4 GPIOs control the routing of OMAP4 peripherals to the corresponding DLPC350 peripherals:

- To power down the output of TFP401 and enable the level shifters in the 24-bit RGB interface, the OMAP4 processor must drive GPIO_140 (SYS_MSTR_MUX_SEL) high.
- To connect the OMAP4 USB3 bus to the DLPC350, OMAP4 must drive GPIO_39 (SYS_USB_SEL) high.
- To connect the OMAP4 I2C2 bus to the DLPC350 I2C1 bus, OMAP4 must drive GPIO_51 (SYS_I2C_OE) high.
- To disconnect UART output of DLPC350 from J20 and route it to OMAP4 UART4, OMAP4 must drive GPIO_33 high.
- To connect the triggers from DLPC350 to OMAP4 GPIOs, OMAP4 must drive GPIO_61 (SYS_TRIGGER_SEL) high.

[Table 6-1](#), [Table 6-2](#), [Table 6-3](#), and [Table 6-4](#) list the signals interfacing the OMAP4 processor in the PandaBoard 4500 with the DLPC350 in the DLP LightCrafter 4500.

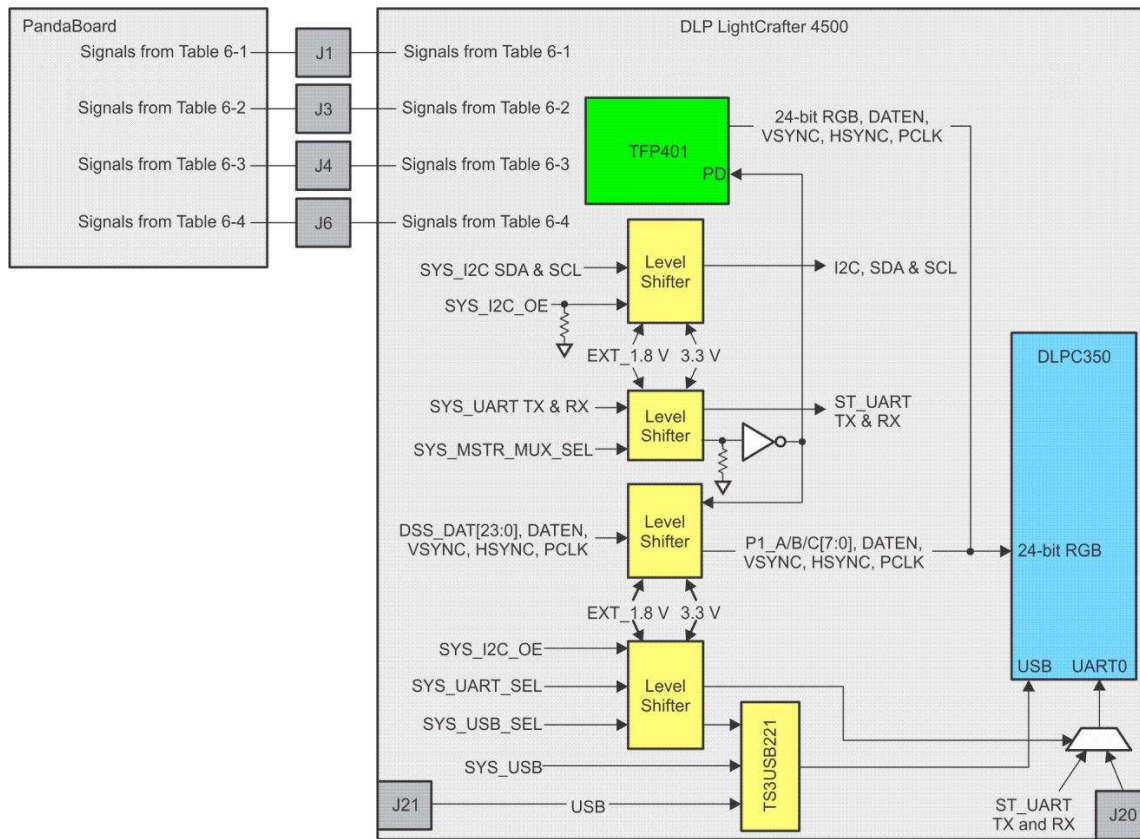

Figure 6-2. Block Diagram of the PandaBoard Interface

Table 6-1. J1 PandaBoard 4500 to DLP LightCrafter 4500 Interface

PandaBoard 4500 J1				DLP LightCrafter 4500 J1			
Pin	Signal	I/O	Description	Pin	Signal	I/O	Description
1	DCIN_JACK	PWR	5 V supplied from DLP LightCrafter 4500	1	PP5POV	PWR	5 V supplied by TLV62130 (U28) of DLP LightCrafter 4500
2	DCIN_JACK	PWR	5 V supplied from DLP LightCrafter 4500	2	PP5POV	PWR	5 V supplied by TLV62130 (U28) of DLP LightCrafter 4500
3	h_DSS_DAT1	O	OMAP4 LCD pixel data bit 1	3	SYS_DATA01	I	DLPC350 P1_A_3 level-shifted to 1.8 V
4	h_DSS_DAT0	O	OMAP4 LCD pixel data bit 0	4	SYS_DATA00	I	DLPC350 P1_A_2 level-shifted to 1.8 V
5	h_DSS_DAT3	O	OMAP4 LCD pixel data bit 3	5	SYS_DATA03	I	DLPC350 P1_A_5 level-shifted to 1.8 V
6	h_DSS_DAT2	O	OMAP4 LCD pixel data bit 2	6	SYS_DATA02	I	DLPC350 P1_A_4 level-shifted to 1.8 V
7	h_DSS_DAT5	O	OMAP4 LCD pixel data bit 5	7	SYS_DATA05	I	DLPC350 P1_A_7 level-shifted to 1.8 V
8	h_DSS_DAT4	O	OMAP4 LCD pixel data bit 4	8	SYS_DATA04	I	DLPC350 P1_A_6 level-shifted to 1.8 V
9	h_DSS_DAT12	O	OMAP4 LCD pixel data bit 12	9	SYS_DATA12	I	DLPC350 P1_B_6 level-shifted to 1.8 V
10	h_DSS_DAT10	O	OMAP4 LCD pixel data bit 10	10	SYS_DATA10	I	DLPC350 P1_B_4 level-shifted to 1.8 V
11	h_DSS_DAT23	O	OMAP4 LCD pixel data bit 23	11	SYS_DATA23	I	DLPC350 P1_C_9 level-shifted to 1.8 V
12	h_DSS_DAT14	O	OMAP4 LCD pixel data bit 14	12	SYS_DATA14	I	DLPC350 P1_B_8 level-shifted to 1.8 V
13	h_DSS_DAT19	O	OMAP4 LCD pixel data bit 19	13	SYS_DATA19	I	DLPC350 P1_C_5 level-shifted to 1.8 V
14	h_DSS_DAT22	O	OMAP4 LCD pixel data bit 22	14	SYS_DATA22	I	DLPC350 P1_C_8 level-shifted to 1.8 V
15	H_I2C2_SDA	I/O	OMAP4 I2C2 serial data	15	SYS_I2C1_SDA	I/O	DLPC350 I2C1_SDA level-shifted to 1.8 V
16	h_DSS_DAT11	O	OMAP4 LCD pixel data bit 11	16	SYS_DATA11	I	DLPC350 P1_B_5 level-shifted to 1.8 V
17	h_DSS_VSYNC	O	OMAP4 LCD vertical sync signal	17	SYS_VSYNC	I	DLPC350 P1_VSYNC level-shifted to 1.8 V
18	H_DPM_EMU2	I	DPM_EMU2/GPIO_13	18	NC		No connect
19	GND	GND	Ground bus	19	GND	GND	Ground bus
20	GND	GND	Ground bus	20	GND	GND	Ground bus

Table 6-2. J3 PandaBoard 4500 to DLP LightCrafter 4500 Interface

PandaBoard 4500 J3				DLP LightCrafter 4500 J3			
Pin	Signal	I/O	Description	Pin	Signal	I/O	Description
1	VIO_1V8	PWR	Panda 1.8-V system I/O voltage	1	EXT_1V8	PWR	1.8 V supplied by Panda
2	DCIN_JACK	PWR	5 V supplied from DLP LightCrafter 4500	2	PP5P0V	PWR	5 V supplied by TLV62130 (U28) of DLP LightCrafter 4500
3	GPMC_AD7	I/O	OMAP4 GPMC address or data bit 7	3	NC		No connect
4	MCSP1_CS3 / GPIO_140	O	OMAP4 SPI1 chip select 3 (also UART1_RTS)	4	SYS_MASTER_MUX_SEL	I	When high, Panda enables the level shifters, muxes the RGB signals to DLPC350, and disables TFP401. When low, RGB signals are muxed to TFP401 and level shifters to Panda are disabled.
5	GPMC_AD6	I/O	OMAP4GPMC address or data bit 6	5	NC		No connect
6	UART4_TX	O	OMAP4 UART4 transmit data	6	SYS_UART0_RX	I	DLPC350 UART0_RX level-shifted to 1.8 V
7	GPMC_AD5	I/O	OMAP4 GPMC address or data bit 5	7	NC		No connect
8	UART4_RX	I	OMAP4 UART4 receive data	8	SYS_UART0_TX0	O	DLPC350 UART0_TX level-shifted to 1.8 V. Outputs error info from DLPC350.
9	GPMC_AD4	I/O	OMAP4 GPMC address or data bit 4	9	NC		No connect
10	MCSP1_CS1 / GPIO_138	O	OMAP4 SPI1 chip select 1 (also UART1_RX)	10	SYS_TRIG_IN_1	I	DLPC350 TRIG_IN_1 level-shifted to 1.8 V. This signal advances the pattern during <i>Pattern Sequence</i> mode.
11	GPMC_AD3	I/O	OMAP4GPMC address or data bit 3	11	NC		No connect
12	MCSP1_SIMO / GPIO_136	I/O	OMAP4 SPI1 slave in master out	12	SYS_TRIG_IN_2	I	DLPC350 TRIG_IN_2 level-shifted to 1.8 V. This signal is used as a start (rising edge) or stop (falling edge) during <i>Pattern Sequence</i> mode.
13	GPMC_AD2	I/O	OMAP4 GPMC address or data bit 2	13	NC		No connect
14	MCSP1_CS2 / GPIO_139	O	OMAP4 SPI1 chip select 2 (also UART1_CTS)	14	DRV_EXT_POWER_ON	O	DLPC350 EXT_POWER_ON level-shifted to 1.8 V. This signal indicates to OMAP4 the DLPC350 is powered ON.
15	GPMC_AD1	I/O	OMAP4 GPMC address or data bit 1	15	NC		No connect
16	MCSP1_CS0 / GPIO_137	I/O	OMAP4 SPI1 chip select 0	16	DRV_TRIG_OUTB_2	O	DLPC350 TRIG_OUT_2 level-shifted to 1.8 V. DLPC350 active high signal to indicate first pattern in <i>Pattern Sequence</i> mode.
17	GPMC_AD0	I/O	OMAP4 GPMC address or data bit 0	17	NC		No Connect
18	MCSP1_SOMI / GPIO_135	I/O	OMAP4 SPI1 slave out master I	18	DRV_TRIG_OUTB_1	O	DLPC350 TRIG_OUT_2 level-shifted to 1.8 V. DLPC350 active high pattern exposure signal during <i>Pattern Sequence</i> mode.
19	GPMC_NWE	O	OMAP4 GPMC write enable	19	NC		No connect
20	MCSP1_CLK / GPIO_134	I/O	OMAP4 SPI1 clock out	20	DRV_INIT_DONE	O	DLPC350INTI_DONE level-shifted to 1.8 V. DLPC350 active high pulse signal to indicate system initialization is complete.
21	GPMC_NOE	O	OMAP4 GPMC output enable	21	NC		No connect
22	GPMC_AD15 / GPIO_39	I/O	OMAP4 GPMC address or data bit 15	22	SYS_USB_SEL	I	Signal from OMAP4 to switch the TS3USB221 mux. When low, driver board USB connector is routed to DLPC350. When high, OMAP4 drives USB to DLPC350.
23	I2C4_SDA	I/O	OMAP4 I2C4 serial data	23	NC		No connect
24	I2C4_SCL	O	OMAP4 I2C4 serial clock	24	NC		No connect
25	REGEN1	O	Panda TWL6030 REGEN1	25	NC		No connect
26	SYS_NRESPWRON	O	Panda power-on reset	26	NC		No connect
27	DGND	GND	Digital ground	27	GND	GND	Digital ground
28	DGND	GND	Digital ground	28	GND	GND	Digital ground

Table 6-3. J4 PandaBoard 4500 to DLP LightCrafter 4500 Interface

PandaBoard 4500 J4				DLP LightCrafter 4500 J4			
Pin	Signal	I/O	Description	Pin	Signal	I/O	Description
1	VDD_V AUX2	PWR	Panda power rail (adjustable from 1.2 V to 2.8 V)	1	NC		No connect
2	VIO_1V8	PWR	Panda 1.8 V system I/O voltage	2	EXT_1V8	PWR	1.8 V supplied by Panda
3	h_DSS_DAT20	O	OMAP4 LCD pixel data bit 20	3	SYS_DATA20	I	DLPC350 P1_C_6 level-shifted to 1.8 V
4	h_DSS_DAT21	O	OMAP4 LCD pixel data bit 21	4	SYS_DATA21	I	DLPC350 P1_C_7 level-shifted to 1.8 V
5	h_DSS_DAT17	O	OMAP4 LCD pixel data bit 17	5	SYS_DATA17	I	DLPC350 P1_C_3 level-shifted to 1.8 V
6	h_DSS_DAT18	O	OMAP4 LCD pixel data bit 18	6	SYS_DATA18	I	DLPC350 P1_C_4 level-shifted to 1.8 V
7	h_DSS_DAT15	O	OMAP4 LCD pixel data bit 15	7	SYS_DATA15	I	DLPC350 P1_B_9 level-shifted to 1.8 V
8	h_DSS_DAT16	O	OMAP4 LCD pixel data bit 16	8	SYS_DATA16	I	DLPC350 P1_C_2 level-shifted to 1.8 V
9	h_DSS_DAT7	O	OMAP4 LCD pixel data bit 7	9	SYS_DATA7	I	DLPC350 P1_A_9 level-shifted to 1.8 V
10	h_DSS_DAT13	O	OMAP4 LCD pixel data bit 13	10	SYS_DATA13	I	DLPC350 P1_B_7 level-shifted to 1.8 V
11	h_DSS_DAT8	O	OMAP4 LCD pixel data bit 8	11	SYS_DATA8	I	DLPC350 P1_B_2 level-shifted to 1.8 V
12	NUSB_PWR	O	Input power enable	12	NC		No connect
13	h_DSS_DAT9	O	OMAP4 LCD pixel data bit 9	13	SYS_DATA09	I	DLPC350 P1_B_3 level-shifted to 1.8 V
14	H_I2C2_SCL	O	OMAP4 I2C2 serial clock	14	SYS_I2C1_SCL	I	DLPC350 I2C1_SCL level-shifted to 1.8 V
15	h_DSS_DAT6	I/O	OMAP4 LCD pixel data bit 6	15	SYS_DATA06	I/O	DLPC350 P1_A_8 level-shifted to 1.8 V
16	h_DSS_PCLK	O	OMAP4 LCD pixel clock	16	SYS_PCLK	I	DLPC350 P1_CLK level-shifted to 1.8 V
17	h_DSS_DEN	O	OMAP4 LCD data enable	17	SYS_DATA_EN	I	DLPC350 P1_DATAEN level-shifted to 1.8 V
18	h_DSS_HSYNC	O	OMAP4 LCD horizontal sync	18	SYS_HSYNC	I	DLPC350 P1_HSYNC level-shifted to 1.8 V
19	GND	GND	Ground bus	19	GND	GND	Digital ground
20	GND	GND	Ground bus	20	GND	GND	Digital ground

Table 6-4. J6 PandaBoard 4500 to DLP LightCrafter 4500 Interface

PandaBoard 4500 J6				DLP LightCrafter 4500 J6			
Pin	Signal	I/O	Description	Pin	Signal	I/O	Description
1	VBUS_3	PWR	OMAP4 VBUS output from USB Host Port #3	1	NC		No connect
2	VBUS_4	PWR	OMAP4 VBUS output from USB Host Port #4	2	NC		No connect
3	USBH3_DM	I/O	OMAP4 USB host port 3 data minus	3	SYS_USB_DN	I/O	TS3USB221 USB DN
4	USBH4_DM	I/O	OMAP4 USB host port 4 data minus	4	NC		No connect
5	USBH3_DP	I/O	OMAP4 USB host port 3 data plus	5	SYS_USB_DP	I/O	TS3USB221 USB DP
6	USBH4_DP	I/O	OMAP4 USB host port 4 data plus	6	NC		No connect
7	DGND	GND	Digital ground	7	GND	GND	Digital ground
8	DGND	GND	Digital ground	8	GND	GND	Digital ground
9	GPMC_AD14 / GPIO_38	I/O	OMAP4 GPMC address or data bit 14	9	DRV_GPIO11	O	DLPC350 GPIO11 (ClockC output) level-shifted to 1.8 V
10	GPMC_AD13 / GPIO_37	I/O	OMAP4 GPMC address or data bit 13	10	DRV_GPIO12	O	DLPC350 GPIO12 (ClockD output) level-shifted to 1.8 V
11	SYS_NRESWAR M	I/O	Panda Warm Reset	11	NC		No connect
12	PB_POWER_O N	I	Power on input to TWL6030 (ref. to VBAT)	12	NC		No connect
13	HFL_P	O	Hands free left speaker out (+)	13	NC		No connect
14	H_DMTIMER11_PWM / GPIO121	O	OMAP4 display PWM control	14	SYS_GPIO5	I	DLPC350 GPIO5 (PWM0 input) level-shifted to 1.8 V
15	HFL_N	O	Hands free left speaker out (-)	15	NC		No connect
16	VDD_V AUX1	PWR	TWL6030 VAUX1	16	NC		No connect
17	GPMC_AD12 / GPIO_36	I/O	OMAP4 GPMC address or data bit 13	17	SYS_GPIO6	I	DLPC350 GPIO6 (PWM1 input) level-shifted to 1.8 V
18	GPMC_AD8 / GPIO_32	I/O	OMAP4 GPMC address or data bit 8	18	DRV_GPIO00	O	DLPC350 GPIO0 (PWM0 output) level-shifted to 1.8 V
19	GPMC_W AIT0 / GPIO_61	I	OMAP4 GPMC Wait input 0	19	SYS_TRIGGER_SEL	I	When high routes DLPC350 trigger inputs to Pandaboard. When low routes DLPC350 trigger inputs to DLP LightCrafter 4500 input trigger connector.
20	GPMC_AD9 / GPIO_33	I/O	OMAP4 GPMC address or data bit 9	20	SYS_UART_SEL	I	When high routes the DLPC350 UART to Pandaboard. When low routes the DLPC350 UART to the DLP LightCrafter 4500 UART connector.

Table 6-4. J6 PandaBoard 4500 to DLP LightCrafter 4500 Interface (continued)

PandaBoard 4500 J6				DLP LightCrafter 4500 J6			
Pin	Signal	I/O	Description	Pin	Signal	I/O	Description
21	GPMC_NWP / GPIO_54	O	OMAP4 GPMC write protect	21	NC		No connect
22	GPMC_AD10 / GPIO_34	I/O	OMAP4 GPMC address or data bit 10	22	DRV_GPIO02	O	DLPC350 GPIO2 (PWM2 output) level-shifted to 1.8 V
23	GPMC_CLK / GPIO_55	O	OMAP4 GPMC Clock Out	23	NC		No connect
24	GPMC_AD11 / GPIO_35	I/O	OMAP4 GPMC address or data bit 11	24	DRV_TRIG_OUTA_1	O	External Trigger Input from connector J11 TRIG1_IN_CONN level-shifted to 1.8 V
25	GPMC_NCS0 / GPIO_50	O	OMAP4 GPMC chip select 0	25	DRV_TRIG_OUTA_2	O	External Trigger Input from connector J11 TRIG2_IN_CONN level-shifted to 1.8 V
26	GPMC_NADV_ALE / GPIO_56	O	OMAP4 GPMC address valid or address latch enable	26	NC		No connect
27	GPMC_NCS1 / GPIO_51	O	OMAP4 GPMC chip select 1	27	SYS_I2C_OE	I	When high, connects the OMAP4 I2C2 bus to DLPC350 I2C1 bus. When low, disconnects the OMAP4 I2C2 bus from the DLPC350 I2C1 bus.
28	GPMC_NBE0_CLE / GPIO_59	O	OMAP4 GPMC byte enable 0 or command latch enable	28	NC		No connect

6.1.2 PandaBoard Software

Note: Only up to revision B2 of the PandaBoard are officially supported

The HDMI connector is the default display output of PandaBoard. To reroute the display video output to the RGB interface of the DLP LightCrafter 4500, the kernel config file must be modified with the following changes:

- Disable DRM
- Enable DVI output
- Enable frame buffer support

To perform these changes, obtain the Ubuntu® kernel from the repository:

- `git clone git://kernel.ubuntu.com/ubuntu/ubuntu-precise.git`
- `git checkout -b working origin/ti-omap4`

Install ARM compilers on Linux® machine:

- `sudo apt-get install gcc-arm-linux-gnueabi gcc-arm-linux-gnueabihf`
- `sudo apt-get install gcc-arm-linux-gnueabi-cpp gcc-arm-linux-gnueabihf-cpp`

To run the menuconfig, install ncurses package:

- `sudo apt-get install build-essential ncurses-dev`

Before compiling the Ubuntu kernel, the DVI port must be enabled. Run menuconfig:

- `cp debian.ti-omap4/config/config.common.ubuntu.config`
- `sudo make ARCH=arm menuconfig`

Select the following:

- Disable DRM under: Device Drivers → Graphics Support → Direct Rendering Manager
- Enable DVI under: Device Drivers → Graphic Support → OMAP2+ Display Subsystem support → OMAP2/3 Display Device Drivers → DVI Output
- Enable frame buffer support: Device Drivers → Graphic Support → OMAP2+ Display Subsystem support → OMAP2+ frame buffer support

Build the kernel:

- `ARCH=arm CROSS_COMPILE=arm-linux-gnueabi- make`

Generate the ulmage:

- `ARCH=arm CROSS_COMPILE=arm-linux-gnueabi- make ulmage`

The generated ulmage will be located at `ubuntu-precise/arch/arm/boot/ulmage`.

To configure the OMAP4 LCD peripheral drive for the DLP LightCrafter 4500 24-bit RGB input, perform the following changes to the boot script. The boot script, boot.scr, is used by U-Boot.

- Set the DVI as the default output by adding the following entry to boot.scr:
 - omapfb.mode=dvi omapdss.def_disp=dvi
- Set the desired resolution fro the DLP LightCrafter 4500 output by adding one of the following entries to boot.scr:
 - omapfb.mode=dvi:912x1140MR-24@60
 - omapfb.mode=dvi:1280x800MR-24@60
- Generate the boot.scr:
 - mkimage -A arm -T script -C none -n "Boot Image" -d boot.script boot.scr
- Copy the generated ulmage and boot.scr in the boot partition of the SD card.

Make the modules:

- Make CROSS_COMPILE=arm-linux-gnueabi- ARCH=arm INSTALL_MOD_PATH=<path_of_modules> modules_install

Copy the 'modules' folder from the path given in the previous command to the \lib folder on secondary partition.

Connectors

This chapter describes the connector pins of the DLP LightCrafter 4500 module.

7.1 Input Trigger Connectors

Table 7-1 lists the input trigger connector (J11) pins. The trigger inputs have hysteresis. Two matching six-pin, 1.25-mm connector part numbers are:

- Molex part number: 51021-0600
- Digi-Key part number: WM1724-ND

The corresponding connector terminal (crimp) part numbers are:

- Molex part number: 50079-8100
- Digi-Key part number: WM2023-ND

Table 7-1. Input Trigger Connector Pins

Description	Pin	Supply Range
Trigger In 1 supply	1	External or internal 1.8-V and 3.3-V selectable at J10
Trigger In 1	2	
Ground	3	Ground
Trigger In 2 supply	4	External or internal 1.8-V and 3.3-V selectable at J12
Trigger In 2	5	
Ground	6	Ground

7.2 Output Trigger Connectors

Table 7-2 lists the output trigger connector (J14) pins. Two matching six-pin, 1.25-mm connector part numbers are:

- Molex part number: 51021-0600
- Digi-Key part number: WM1724-ND

The corresponding connector terminal (crimp) part numbers are:

- Molex part number: 50079-8100
- Digi-Key part number: WM2023-ND

Table 7-2. Output Trigger Connector Pins

Description	Pin	Supply Range
Trigger Out 1 supply	1	1.8-V and 3.3-V selectable at J13
Trigger Out 1	2	
Ground	3	Ground
Trigger Out 2 supply	4	1.8-V and 3.3-V selectable at J15
Trigger Out 2	5	
Ground	6	Ground

7.3 DLPC350 UART

The DLPC350 UART compatible cable:

- Leopard Imaging: LI-SER-01
- Mouser part number: 931-LI-SER-01

Table 7-3 lists UART connector (J20) pins.

Table 7-3. UART Connector Pins

Description	Pin	Supply Range
Ground	1	0 V
RX	2	3.3 V
TX	3	3.3 V

7.4 DLPC350 I2C0

Table 7-4 lists the I2C0 connector (J16) pins. Two matching four-pin, 1.25-mm connector part numbers are:

- Molex part number: 51021-0400
- Digi-Key part number: WM1722-ND

The corresponding terminal (crimp) part numbers are:

- Molex part number: 50079-8100
- Digi-Key part number: WM2023-ND

Table 7-4. I²C0 Connector Pins

Description	Pin	Supply Range
I ² C SCL	1	3.3 V
I ² C SDA	2	3.3 V
3.3-V supply	3	3.3 V
Ground	4	0 V

7.5 DLPC350 I2C1

Table 7-5 lists the I2C1 connector (J17) pins. Two matching four-pin, 1.25-mm connector part numbers are:

- Molex part number: 51021-0400
- Digi-Key part number: WM1722-ND

The corresponding terminal (crimp) part numbers are:

- Molex part number: 50079-8100
- Digi-Key part number: WM2023-ND

Table 7-5. I²C1 Connector Pins

Description	Pin	Supply Range
I ² C SCL	1	3.3 V
I ² C SDA	2	3.3 V
3.3-V supply	3	3.3 V
Ground	4	0 V

7.6 Fan

Table 7-6 lists the fan connector (J22) pins. Two matching three-pin, 1.25-mm connector part numbers are:

- Molex part number: 51021-0300
- Digi-Key part number: WM1722-ND

The corresponding terminal (crimp) part numbers are:

- Molex part number: 50079-8100
- Digi-Key part number: WM2023-ND

Table 7-6. Fan Connector Pins

Description	Pin	Supply Range
Power	1	12 V
FAN_LOCKED	2	3.3 V
Ground	3	0 V

7.7 Red LED

Table 7-7 lists the red LED connector (J31) pins. Two matching nine-pin, 1.5-mm connector part numbers are:

- Molex part number: 87439-0900
- Digi-Key part number: WM2093-ND

The corresponding terminal (crimp) part numbers are:

- Molex part number: 87421-0000
- Digi-Key part number: WM1112-ND

Table 7-7. Red LED Connector Pins

Description	Pin	Supply Range
Ground	1	0 V
Temperature sensor	2	3.3 V
3.3-V supply	3	3.3 V
Red anode	4	3 V
Red anode	5	3 V
Red anode	6	3 V
Red cathode	7	0 V
Red cathode	8	0 V
Red cathode	9	0 V

7.8 Green LED

Table 7-8 lists the green LED connector (J32) pins. Two matching six-pin, 1.5-mm connector part numbers are:

- Molex part number: 87439-0600
- Digi-Key part number: WM2093-ND

The corresponding terminal (crimp) part numbers are:

- Molex part number: 87421-0000
- Digi-Key part number: WM1112-ND

Table 7-8. Green LED Connector Pins

Description	Pin	Supply Range
Green anode	1	4.3 V
Green anode	2	4.3 V
Green anode	3	4.3 V
Green cathode	4	0 V
Green cathode	5	0 V
Green cathode	6	0 V

7.9 Blue LED

Table 7-9 lists the blue LED connector (J33) pins. Two matching six-pin, 1.5-mm connector part numbers are:

- Molex part number: 87439-0600
- Digi-Key part number: WM2093-ND

The corresponding terminal (crimp) part numbers are:

- Molex part number: 87421-0000
- Digi-Key part number: WM1112-ND

Table 7-9. Blue LED Connector Pins

Description	Pin	Supply Range
Blue anode	1	4.3 V
Blue anode	2	4.3 V
Blue anode	3	4.3 V
Blue cathode	4	0 V
Blue cathode	5	0 V
Blue cathode	6	0 V

7.10 FPD-Link

Table 7-10 lists the FPD-Link connector (J9) pins. The 20-pin, 0.5 SMT header is:

- Panasonic part number: AXK6S20647YG

Table 7-10. FPD-Link Connector Pins

Description	Pin	Supply Range
RCK_IN_P	1	1.2 V
RXE_AP	2	1.2 V
Ground	3	0 V
Ground	4	0 V
RCK_IN_N	5	1.2 V
RXE_AN	6	1.2 V
RXE_BP	7	1.2 V
RXE_CP	8	1.2 V
Ground	9	0 V
Ground	10	0 V
RXE_BN	11	1.2 V
RXE_CN	12	1.2 V
RXE_DP	13	1.2 V

Table 7-10. FPD-Link Connector Pins (continued)

Description	Pin	Supply Range
RXE_EP	14	1.2 V
Ground	15	0 V
Ground	16	0 V
RXE_DN	17	1.2 V
RXE_EN	18	1.2 V
NC	19	N/A
NC	20	N/A

7.11 JTAG Boundary Scan

Table 7-11 lists the JTAG boundary connector (J25) pins. Two matching six-pin, 1.25-mm connector part numbers are:

- Molex part number: 51021-0600
- Digi-Key part number: WM1724-ND

The corresponding connector terminal (crimp) part numbers are:

- Molex part number: 50079-8100
- Digi-Key part number: WM2023-ND

Table 7-11. JTAG Boundary Scan Connector Pins

Description	Pin	Supply Range
TRST	1	3.3 V
TDI	2	3.3 V
TMS1	3	3.3 V
TDO1	4	3.3 V
TCK	5	3.3 V
Ground	6	Ground

7.12 Power

Table 7-12 lists the power socket (J26) pins. Two matching connector part numbers are:

- Switchcraft part number: 760
- Digi-Key part number: SC1051-ND

Table 7-12. Power Connector Pins

Description	Pin	Supply Range
Input supply	1	12 V
Ground	2	0 V
Ground	3	0 V

Safety**WARNING**

Possible hazardous optical radiation emitted from this product. Do not stare at operating LEDs. May be harmful to eyes. Also, avoid touching components during operation.

CAUTION

To minimize the risk of fire or equipment damage, make sure that air is allowed to circulate freely around the DLP LightCrafter 4500 board when operating.

CAUTION

The kit contains ESD-sensitive components. Handle with care to prevent permanent damage.

Power Supply Requirements

B.1 External Power Supply Requirements

The DLP LightCrafter 4500 does not include a power supply. The external power supply requirements are:

- Nominal voltage: 12-V DC
- Minimum current: 0 A
- Maximum Current: 7 A
- DC connector size:
 - Inner diameter: 2.5 mm
 - Outer diameter: 5.5 mm
 - Shaft: 9.5-mm female, center positive
- Efficiency level: V

NOTE: External Power Supply Regulatory Compliance Certifications: Recommend selection and use of an external power supply, which meets TI's required minimum electrical ratings in addition to complying with applicable regional product regulatory and safety certification requirements such as (by example) UL, CSA, VDE, CCC, PSE, and so forth.

Revision History

NOTE: Page numbers for previous revisions may differ from page numbers in the current version.

Changes from E Revision (September 2015) to F Revision	Page
• Value of throw ratio updated from 1.4 to 1.2 in Table 1-1	10
• Added note to Section 3.2.2 on sustaining operating modes	24
• Clarified in pattern sequence creation step #6 that Play Once does not always work in video mode in Section 3.3.1	30
• Updated steps in Section 3.4 to include description of fast flash update and skip bootloader update	37
• Added language on including .bin extension on step #7 of adding 24-bit image to firmware file in Section 3.5	40
• Added note to Section 5.2 on limitations to the use of saved solutions	46

IMPORTANT NOTICE FOR TI DESIGN INFORMATION AND RESOURCES

Texas Instruments Incorporated ("TI") technical, application or other design advice, services or information, including, but not limited to, reference designs and materials relating to evaluation modules, (collectively, "TI Resources") are intended to assist designers who are developing applications that incorporate TI products; by downloading, accessing or using any particular TI Resource in any way, you (individually or, if you are acting on behalf of a company, your company) agree to use it solely for this purpose and subject to the terms of this Notice.

TI's provision of TI Resources does not expand or otherwise alter TI's applicable published warranties or warranty disclaimers for TI products, and no additional obligations or liabilities arise from TI providing such TI Resources. TI reserves the right to make corrections, enhancements, improvements and other changes to its TI Resources.

You understand and agree that you remain responsible for using your independent analysis, evaluation and judgment in designing your applications and that you have full and exclusive responsibility to assure the safety of your applications and compliance of your applications (and of all TI products used in or for your applications) with all applicable regulations, laws and other applicable requirements. You represent that, with respect to your applications, you have all the necessary expertise to create and implement safeguards that (1) anticipate dangerous consequences of failures, (2) monitor failures and their consequences, and (3) lessen the likelihood of failures that might cause harm and take appropriate actions. You agree that prior to using or distributing any applications that include TI products, you will thoroughly test such applications and the functionality of such TI products as used in such applications. TI has not conducted any testing other than that specifically described in the published documentation for a particular TI Resource.

You are authorized to use, copy and modify any individual TI Resource only in connection with the development of applications that include the TI product(s) identified in such TI Resource. NO OTHER LICENSE, EXPRESS OR IMPLIED, BY ESTOPPEL OR OTHERWISE TO ANY OTHER TI INTELLECTUAL PROPERTY RIGHT, AND NO LICENSE TO ANY TECHNOLOGY OR INTELLECTUAL PROPERTY RIGHT OF TI OR ANY THIRD PARTY IS GRANTED HEREIN, including but not limited to any patent right, copyright, mask work right, or other intellectual property right relating to any combination, machine, or process in which TI products or services are used. Information regarding or referencing third-party products or services does not constitute a license to use such products or services, or a warranty or endorsement thereof. Use of TI Resources may require a license from a third party under the patents or other intellectual property of the third party, or a license from TI under the patents or other intellectual property of TI.

TI RESOURCES ARE PROVIDED "AS IS" AND WITH ALL FAULTS. TI DISCLAIMS ALL OTHER WARRANTIES OR REPRESENTATIONS, EXPRESS OR IMPLIED, REGARDING TI RESOURCES OR USE THEREOF, INCLUDING BUT NOT LIMITED TO ACCURACY OR COMPLETENESS, TITLE, ANY EPIDEMIC FAILURE WARRANTY AND ANY IMPLIED WARRANTIES OF MERCHANTABILITY, FITNESS FOR A PARTICULAR PURPOSE, AND NON-INFRINGEMENT OF ANY THIRD PARTY INTELLECTUAL PROPERTY RIGHTS.

TI SHALL NOT BE LIABLE FOR AND SHALL NOT DEFEND OR INDEMNIFY YOU AGAINST ANY CLAIM, INCLUDING BUT NOT LIMITED TO ANY INFRINGEMENT CLAIM THAT RELATES TO OR IS BASED ON ANY COMBINATION OF PRODUCTS EVEN IF DESCRIBED IN TI RESOURCES OR OTHERWISE. IN NO EVENT SHALL TI BE LIABLE FOR ANY ACTUAL, DIRECT, SPECIAL, COLLATERAL, INDIRECT, PUNITIVE, INCIDENTAL, CONSEQUENTIAL OR EXEMPLARY DAMAGES IN CONNECTION WITH OR ARISING OUT OF TI RESOURCES OR USE THEREOF, AND REGARDLESS OF WHETHER TI HAS BEEN ADVISED OF THE POSSIBILITY OF SUCH DAMAGES.

You agree to fully indemnify TI and its representatives against any damages, costs, losses, and/or liabilities arising out of your non-compliance with the terms and provisions of this Notice.

This Notice applies to TI Resources. Additional terms apply to the use and purchase of certain types of materials, TI products and services. These include; without limitation, TI's standard terms for semiconductor products (<http://www.ti.com/sc/docs/stdterms.htm>), [evaluation modules](#), and [samples](http://www.ti.com/sc/docs/sampterm.htm) (<http://www.ti.com/sc/docs/sampterm.htm>).

Mailing Address: Texas Instruments, Post Office Box 655303, Dallas, Texas 75265
Copyright © 2017, Texas Instruments Incorporated

Looking for pricing, stock, or lifecycle information?

Click below to explore more details on WIN SOURCE:

 [View DLPLCR4500EVM on WIN SOURCE](#)

 [Texas Instruments](#) Information

Optimize Your Supply Chain with WIN SOURCE Solutions

-  Global Sourcing Solution
-  Obsolete Management
-  Cost Control Management
-  Shortage Management
-  Alternative Solution
-  Excess Inventory Management