



**THE DATASHEET OF  
EZR-LEDK2W-915**





# Si4455-2WayLink-DEMO

## Si4455 EZRADIO<sup>®</sup> TWO-WAY LINK DEMO KIT USER'S GUIDE

### 1. Kit Overview

This user's guide describes Silicon Labs' Si4455 EZRadio<sup>®</sup> Two-Way Link demo kit. The kit contains two RF nodes based on the RFStick board to support evaluation and development of sub-GHz RF links with the Si4455 EZRadio IC. The kit has three versions: one for the 434-MHz band, one for the 868-MHz band, and one for the 915-MHz band. The content of the different kits are listed in Table 1. These kits are built with the B1A version of the Si4455 IC. RFSticks that are built with the latest C version of the Si4455 ICs can be ordered from Silicon Labs individually under the part numbers Si4455CLEd-434-PER, Si4455CLEd-868-PER, and Si4455CLEd-915-PER.

- The RFStick has four LEDs to display information and four push-buttons to receive user commands. Additionally, the Silicon Labs' Toolstick Base Adapter is provided in the kits to connect the RFStick to the PC for downloading and debugging user applications.
- The kits support use of the Wireless Development Suite (WDS) for setting radio parameters and managing sample codes.
- The kits support the use of the Silicon Labs Integrated Development Environment (IDE) for software debugging and the use of the Keil C compiler, assembler, and linker toolchain.

**Table 1. Kit Contents**

Qty	Part Number	Description
	<b>EZR-LEDK2W-434</b>	<b>Si4455 EZRadio Two-Way Link Demo Kit 434 MHz</b>
2	4455-LED-434-PER	Si4455 RFStick 434 MHz EZRadio transceiver board
2	Toolstick_BA	Toolstick Base Adapter
2	USB-XTEN-01	USB extender cable (USBA-USBA)
4	AAA	AAA alkaline battery
	<b>EZR-LEDK2W-868</b>	<b>Si4455 EZRadio Two-Way Link Demo Kit 868 MHz</b>
2	4455-LED-868-PER	Si4455 RFStick 868 MHz EZRadio transceiver board
2	Toolstick_BA	Toolstick Base Adapter
2	USB-XTEN-01	USB extender cable (USBA-USBA)
4	AAA	AAA alkaline battery
	<b>EZR-LEDK2W-915</b>	<b>Si4455 EZRadio Two-Way Link Demo Kit 915 MHz</b>
2	4455-LED-915-PER	Si4455 RFStick 915 MHz EZRadio transceiver board
2	Toolstick_BA	Toolstick Base Adapter
2	USB-XTEN-01	USB extender cable (USBA-USBA)
4	AAA	AAA alkaline battery

# Si4455-2WayLink-DEMO

---

## 2. Software Setup

There are two software tools provided by Silicon Labs to aid in EZRadio® software development: the Wireless Development Suite (WDS) and the Silicon Labs Integrated Development Environment (IDE). The recommended starting point for EZRadio development is the WDS software tool. This tool is able to identify the connected boards by reading their identification memories (EBID) and provides valuable help by greatly simplifying radio configuration, evaluation, and application development.

### 2.1. Hardware and Software Requirements for WDS

- Windows XP® or later
- Microsoft .NET framework 3.5 or later
- Silicon Labs CP210x VCP driver
- WDS v3.1.9.0 or later

The lack of the .NET framework and VCP driver are recognized during the WDS installation. The install wizard will install the missing components after prompting the user for permission.

### 2.2. Download WDS

WDS can be obtained from the Silicon Labs web site free of charge. For more information, see link in Chapter 4. "Useful Documents" on page 3.

### 2.3. Installation Steps

**Note:** Before installing this software, local administration rights must be obtained from your network administrator.

1. Start WDS3-Setup.exe
2. Click "Next" to start the installation process
3. Accept the license agreement by clicking the check box, and then press the "Next" button.
4. Select the installation folder.  
Using the default folder is recommended, C:\Program Files\Silabs\WDS3
5. When your settings are confirmed, click "Install" to continue.
6. Click "Finish" to close the WDS Installer.

## 3. Hardware Setup

After checking the kit contents against Table 1, the kit can be put into operation by performing the steps listed below for both nodes.

1. Select the USB port as power source by setting the S6 power selector switch to the "Adapter" position.
2. Connect the J1 connector of the RFStick to the Toolstick Base Adapter.
3. Start the WDS on your PC.
4. Connect the Toolstick Base Adapter to a USB port of the PC.
5. Wait for Windows to install the driver of the Toolstick Base Adapter, if necessary.
6. WDS must identify the connected board and open an Application Manager window that lists information about the identified board.
7. Select "Radio Configuration Application" and click "Select Application".
8. From the Radio Configuration Application window, select "Standard Packet TX" for one node and "Standard Packet RX" for the other node.
9. Leave the default parameter settings untouched; simply click "Download project".

Now, the simple TX/RX sample project is running on the boards. When pressing one of the SW1 to SW4 buttons on the TX board, packets are sent, and the corresponding LED of LED1 to LED4 lights up during the transmission. On the RX side LED1 is always on, while different combinations of LED2 to LED4 lights up during successful packet reception, according to the button pressed.

## 4. Useful Documents

For general information on the EZRadio® Si4455 IC, see the data sheet:

[Si4455 Data Sheet](#)

For detailed information on example codes and how to program the EZRadio ICs, refer to the following documents:

[AN692: Si4355/4455 Programming Guide and Sample Codes](#)

[EZRadio API Documentation](#)

Available Tools:

[8-bit Microcontroller Studio \(including Silabs IDE\)](#)

[WDS3 installer](#)

For hardware design guidance, see the following application notes:

[AN685: Layout Design Guide for the Si4455/4355 RF ICs](#)

[AN686: Antennas for the Si4455/4355 RF ICs](#)

[AN693: Si4455 Low-Power PA Matching](#)

For detailed information on lab measurements, data sheet parameter verification and how sample codes can be configured and downloaded to the RFStick from WDS, refer to the following documents:

[AN655: Range Test Application for the EZRadio and EZRadioPRO devices](#)

[AN796: Wireless Development Suite General Description](#)

[AN797: WDS User's Guide for EZRadio Devices](#)

More useful documents can be accessed via the [EZRadio web pages](#)

# Si4455-2WayLink-DEMO

## 5. The RFStick Platform

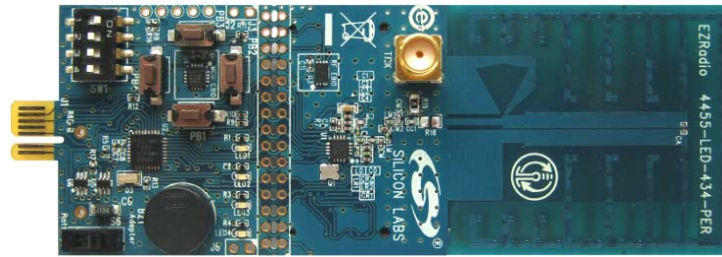

**Figure 1. RFStick**

The RFStick is a basic demo system for the evaluation of the EZRadio chips. The board has two main parts, the MCU part and the radio part. The MCU part of the board contains a Silicon Labs C8051F930 MCU and basic human interface devices (four push-buttons, four LEDs, four switches and a buzzer). The radio part contains the EZRadio chip, the matching circuit, and the antenna. The RF output is selectable via a 0  $\Omega$  resistor between a PCB antenna and an optional (unpopulated) 50  $\Omega$  SMA output connector. The MCU is connected to the EZRadio chip via an SPI bus and some other GPIOs (see Table 2). The RF section of the board can be broken off along a perforation between the two rows of J3 and installed in the user's own hardware as a radio module by utilizing the remaining row of J3.

Table 2 contains the signal connections between the EZRadio chip and the MCU:

**Table 2. Connections between the EZRadio Chip and the MCU**

Si4355, Si4455			RFStick		C80C51F930
Pin Number	Pin Name	Pin Function	Connections across J3	Signal Name	Pin Name
EP, 1, 6, 9	GND	Ground	3–4	GND	GND
7, 8	VDD	Supply Voltage input	1–2	VDD	VDD
12	NIRQ	Interrupt output, active low	19–20	NIRQ	P1.4
2	SDN	Shutdown input, active high	5–6	SDN	P1.5
16	NSEL	SPI select input	11–12	NSEL	P1.3
13	SCLK	SPI clock input	17–18	SCLK	P1.0
15	SDI	SPI data input	13–14	MOSI	P1.2
14	SDO	SPI data output	15–16	MISO	P1.1
10	GPIO_0	General Purpose I/O	23 x 24	GPIO_0/PB1	P0.0
11	GPIO_1	General Purpose I/O	21 x 22	GPIO_1/PB2	P0.1
19	GPIO_2	General Purpose I/O	9 x 10	GPIO_2/PB3	P0.2
20	GPIO_3	General Purpose I/O	7 x 8	GPIO_3/PB4	P0.3

The four GPIO signals' primary function is push button input to the MCU (PB1–PB4), so these signals are not

connected to the EZRadio chip by default (represented by x in the table above). The user can connect them by soldering in jumpers across the appropriate pins of J3.

## 5.1. Setting up and Connecting the RFStick to a PC

The power source of the board can be selected with the power-supply selector switch (S6). If S6 is in the Adapter position, supply voltage is provided by a Toolstick Base Adapter that is connected to the J1 PCB edge connector. If S6 is in the Battery position, the supply voltage is provided by two AAA batteries in the battery holder on the bottom side of the board. Current consumption of the RF part (RFVDD) can be measured on J6. Since J6 is shorted by a PCB track on the bottom side of the board, the user must cut the track if this feature is used.



**Figure 2. How to Connect the RFStick to the PC**

Steps for connecting to a PC:

- Select the desired power source with S6 power selector switch.
- Connect the J1 connector of the RFStick to the Toolstick Base Adapter.
- Connect the Toolstick Base Adapter to the USB port of the PC.
- Wait for Windows to install the driver of the Toolstick Base Adapter, if necessary.

The RFStick is available in three different frequency band versions from Silicon Labs as part of several EZRadio kits.



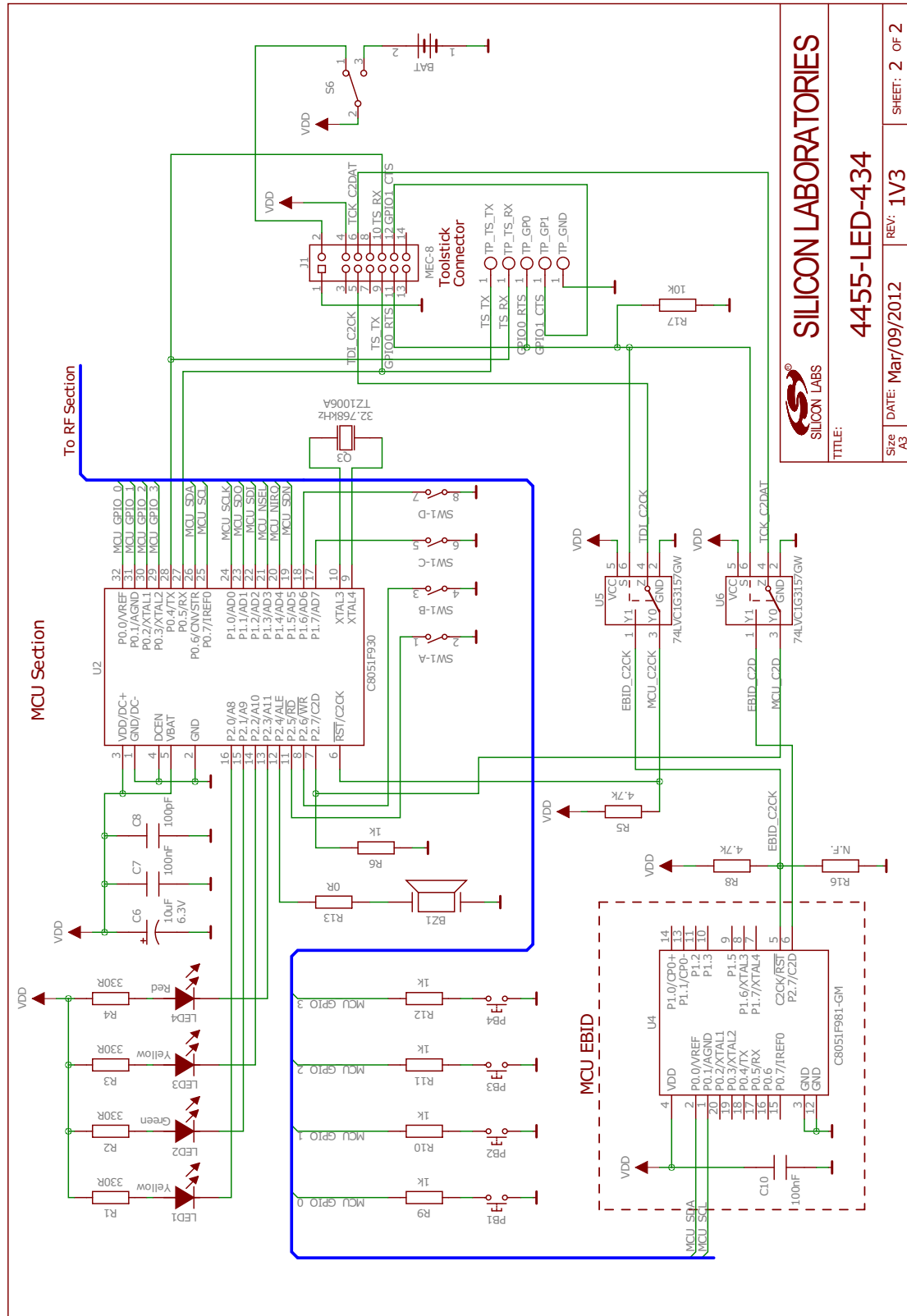

**SILICON LABS**  
**SILICON LABORATORIES**  
**4455-LED-434**  
 TITLE:  
 Size A3 DATE: Mar/09/2012 REV: 1V3 SHEET: 2 OF 2

Figure 4. Si4455-LED-434 Schematic 2

# Si4455-2WayLink-DEMO

---

## DOCUMENT CHANGE LIST

### Revision 0.1 to Revision 0.2

- Changed Figure 6 from RF section to MCU section.

### Revision 0.2 to Revision 0.3.

- Added description of software setup.
- Added details to hardware description.
- Removed description of obsolete range test demo code.
- Added links to other documents

### Revision 0.3 to Revision 0.4

- Updated Kit Overview paragraph on page 1.

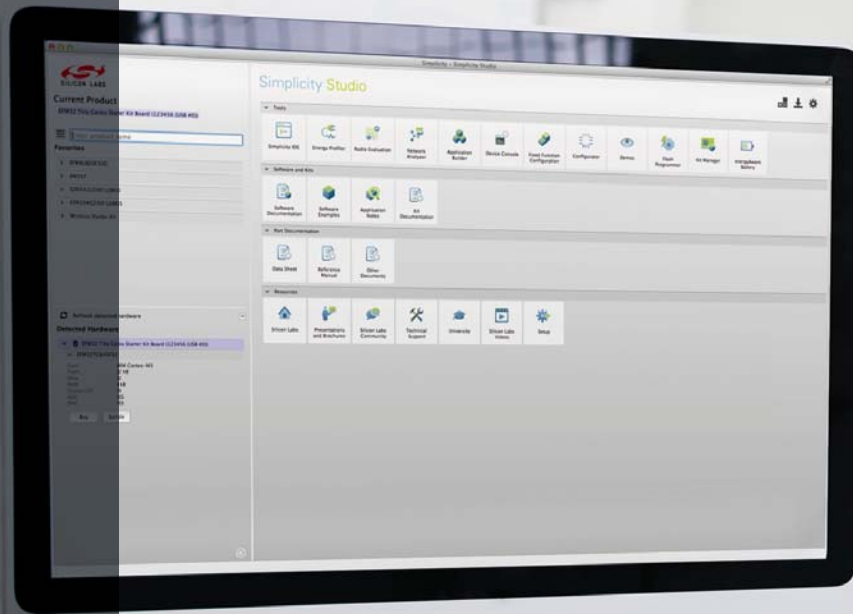

## Simplicity Studio

One-click access to MCU and wireless tools, documentation, software, source code libraries & more. Available for Windows, Mac and Linux!



**IoT Portfolio**  
[www.silabs.com/IoT](http://www.silabs.com/IoT)



**SW/HW**  
[www.silabs.com/simplicity](http://www.silabs.com/simplicity)



**Quality**  
[www.silabs.com/quality](http://www.silabs.com/quality)



**Support and Community**  
[community.silabs.com](http://community.silabs.com)

### Disclaimer

Silicon Laboratories intends to provide customers with the latest, accurate, and in-depth documentation of all peripherals and modules available for system and software implementers using or intending to use the Silicon Laboratories products. Characterization data, available modules and peripherals, memory sizes and memory addresses refer to each specific device, and "Typical" parameters provided can and do vary in different applications. Application examples described herein are for illustrative purposes only. Silicon Laboratories reserves the right to make changes without further notice and limitation to product information, specifications, and descriptions herein, and does not give warranties as to the accuracy or completeness of the included information. Silicon Laboratories shall have no liability for the consequences of use of the information supplied herein. This document does not imply or express copyright licenses granted hereunder to design or fabricate any integrated circuits. The products must not be used within any Life Support System without the specific written consent of Silicon Laboratories. A "Life Support System" is any product or system intended to support or sustain life and/or health, which, if it fails, can be reasonably expected to result in significant personal injury or death. Silicon Laboratories products are generally not intended for military applications. Silicon Laboratories products shall under no circumstances be used in weapons of mass destruction including (but not limited to) nuclear, biological or chemical weapons, or missiles capable of delivering such weapons.

### Trademark Information

Silicon Laboratories Inc., Silicon Laboratories, Silicon Labs, SiLabs and the Silicon Labs logo, CMEMS®, EFM, EFM32, EFR, Energy Micro, Energy Micro logo and combinations thereof, "the world's most energy friendly microcontrollers", Ember®, EZLink®, EZMac®, EZRadio®, EZRadioPRO®, DSPLL®, ISOmodem®, Precision32®, ProSLIC®, SiPHY®, USBXpress® and others are trademarks or registered trademarks of Silicon Laboratories Inc. ARM, CORTEX, Cortex-M3 and THUMB are trademarks or registered trademarks of ARM Holdings. Keil is a registered trademark of ARM Limited. All other products or brand names mentioned herein are trademarks of their respective holders.



**SILICON LABS**

Silicon Laboratories Inc.  
 400 West Cesar Chavez  
 Austin, TX 78701  
 USA

<http://www.silabs.com>

## Looking for pricing, stock, or lifecycle information?

Click below to explore more details on WIN SOURCE:

 [View EZR-LEDK2W-915 on WIN SOURCE](#)

 [Silicon Labs](#) Information

## Optimize Your Supply Chain with WIN SOURCE Solutions

-  Global Sourcing Solution
-  Obsolete Management
-  Cost Control Management
-  Shortage Management
-  Alternative Solution
-  Excess Inventory Management